

# SWISS MODULAR<sup>®</sup>

by Triag International AG

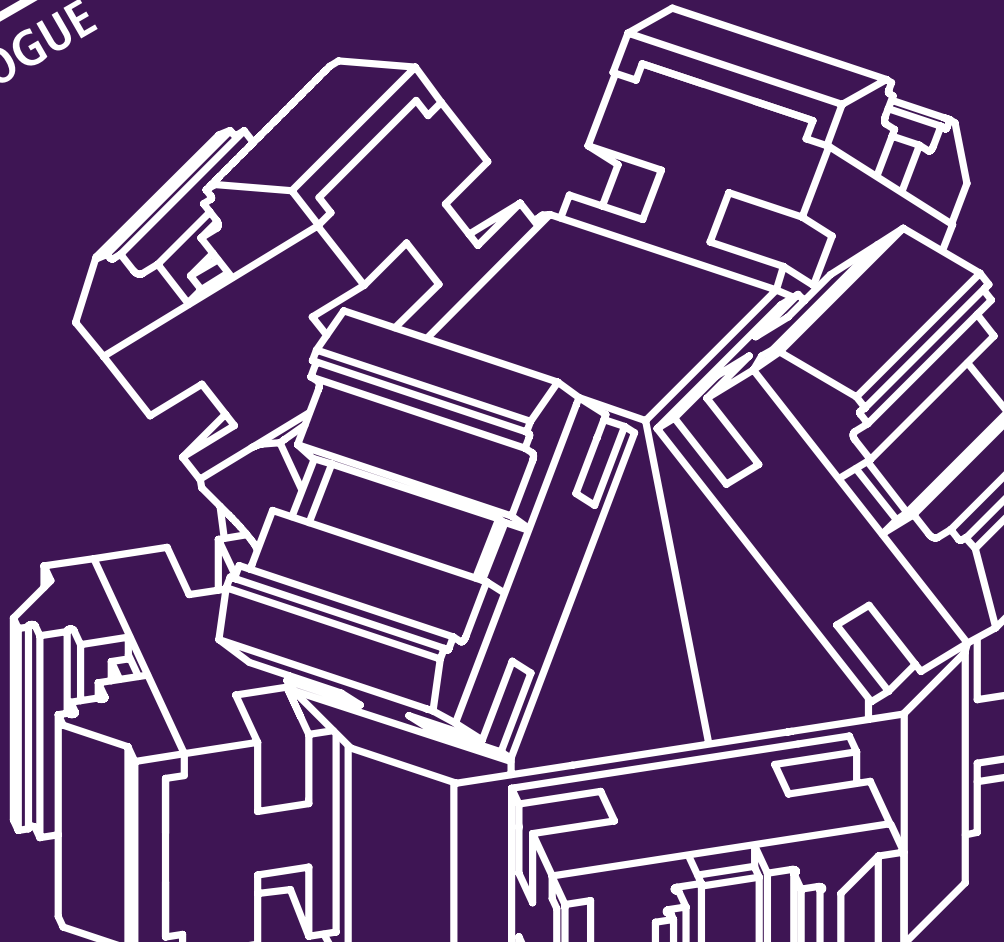

# Inhalt Content

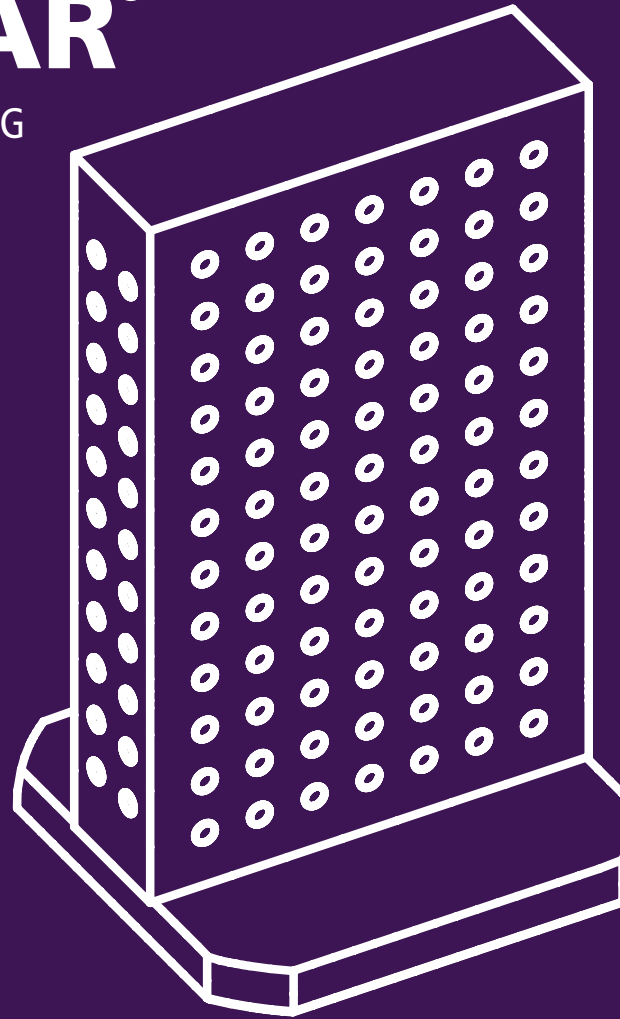
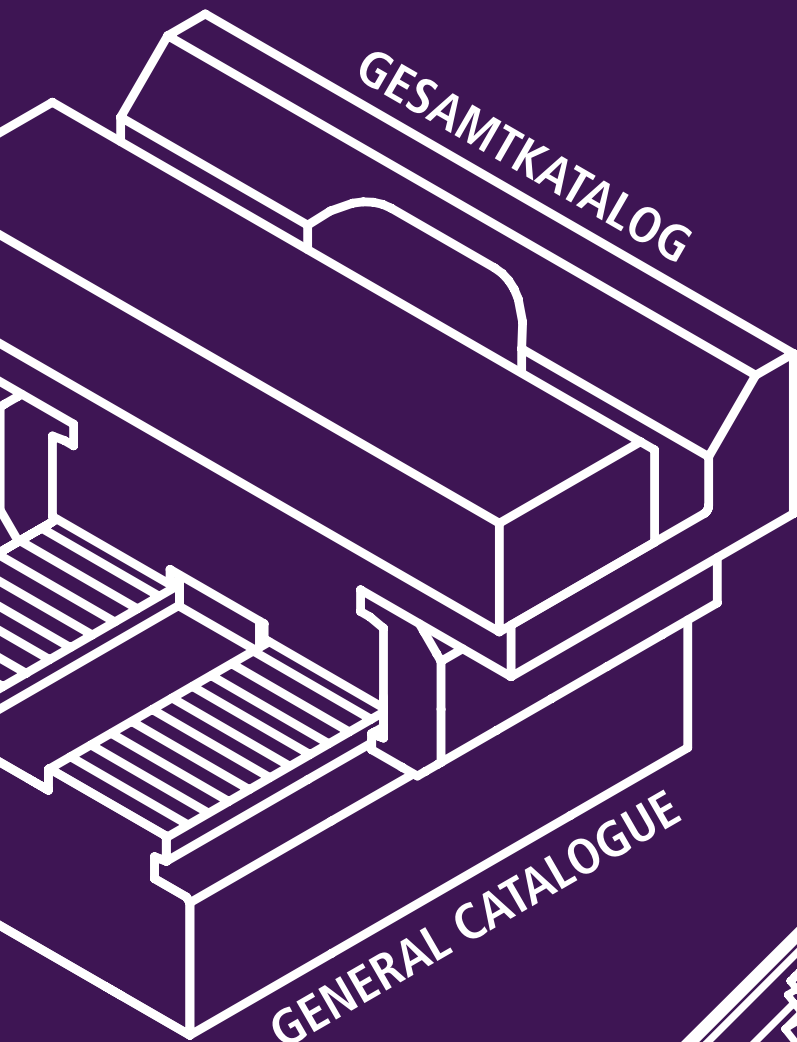

## **powerCLAMP**

**13 - 112**

Der Lego-Schraubstock 3D Modular  
*The lego-vise - 3D modular*



## **tricENTRO**

**113 - 162**

Modulare Zentrischspanner  
*Modular self centering vises*



## **microCLAMP**

**163 - 206**

Spannmodule für den Vorrichtungsbau  
*Clamping modules for dedicated fixtures*



## **aptoCLAMP**

**207 - 234**

Das stärkste Spannsystem  
*The strongest workholding system*

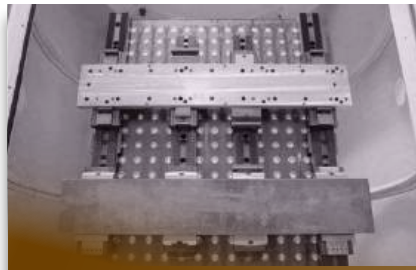

## **tripoxyMINERAL**

**235 - 278**

Eliminiert Vibrationen und ist leicht  
*Eliminates vibrations and is low in weight*

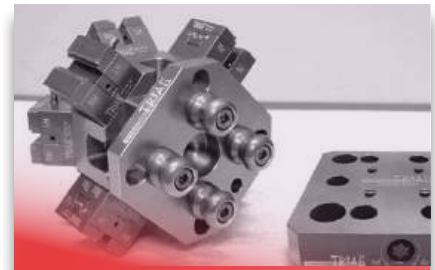

## **oppSYSTEM**

**279 - 302**

Schneller Umrüsten mit Nullpunktsystemen  
*Zero point - quick change systems*



## **trivaCLAMP**

**303 - 328**

Spannen mit Vakuum  
*Clamping with vacuum*



## **customCLAMP**

**329 - 332**

Sondervorrichtungen  
*Custom made fixtures*



## **Zubehör / Accessoires**

**333 - 340**

## **INDEX**

**341 - 346**

## Über uns About us

**1990** Die Triag AG wurde im Jahr 1990 von Edi Zängerle, Ursula Landtwing und Beat Baumgartner gegründet. Sie vertrieb ihre Spannsysteme sowie Zerspanungswerkzeuge namhafter Hersteller hauptsächlich auf dem Schweizer Markt.

**HEUTE** Wir, die Triag International AG, konzentrieren uns seither auf die Entwicklung, Produktion sowie den weltweiten Vertrieb unserer modernen Spannsysteme. Sowohl mit unserem tiefen und breiten Standard Sortiment, als auch mittels werkstückspezifischen Sonderlösungen möchten wir unseren Kunden dabei helfen, ihren Maschinenraum optimal auszunutzen, um dadurch die grösstmögliche Effizienz zu erzielen. Unsere Spannsysteme können von der konventionellen Fräsmaschine bis hin zu modernen 5-Achs-Fräszentren mit oder ohne Automatisierung eingesetzt werden. Diese Effizienz nutzen wir auch in der Herstellung unserer Spannsysteme in unserer eigenen Fertigung.

Auf ein gutes Arbeitsklima und unsere Umwelt legen wir sehr grossen Wert, denn nur mit einem funktionierenden Team und einem grossen Umweltbewusstsein können wir unsere Kunden offen und nachhaltig bedienen.

**1990** Triag AG was founded in 1990 by Edi Zängerle, Ursula Landtwing and Beat Baumgartner. Triag AG distributed its clamping systems as well as cutting tools of well-known manufacturers primarily on the Swiss market.

**TODAY** Triag International AG concentrates on the development, manufacturing and worldwide distribution of our modern clamping systems. With our wide range of standard products as well as by means of custom-built solutions we aim to help our customers to get the most out of their machine space in order to achieve the highest efficiency possible. Our modular workholding systems can be applied from conventional up to 5-axis milling machines, with or without automation. We benefit this efficiency in in our own production too.

We focus on a good working atmosphere and place great value on our environment. We believe that these factors are essential to provide an open and sustainable service.



**Übernahme der Geschäftsleitung durch die nächste Generation.**

**2024**

*Takeover of management by the next generation.*

**Triag International AG launcht die neue Marke swissMODULAR. Die Marke umfasst das gesamte Sortiment an Spannsystemen und Mineralgusstürmen.**

**2023**

*Triag International AG has rebranded to swissMODULAR. The new brand includes the whole range of clamping systems and epoxy mineral tombstones.*

**Entstehung der Triag International AG und der Schwesterfirma Tribur Invent GmbH, die sich auf den weltweiten Vertrieb mit eigenem Engineering, eigener Produktion und Mineralguss Giesserei konzentrieren.**

**2013**

*The formation of Triag International AG and the sister company Tribur Invent GmbH, which are focusing on worldwide distribution with their own engineering, manufacturing and epoxy mineral casting.*

**Gründung der Triag AG**

**1990**

*Foundation of Triag AG*

Im Herzen der Schweiz  
*In the heart of Switzerland*

**swiss**   
**MODULAR**<sup>®</sup>

by Triag International AG



### Triag International AG

Bösch 84 CH-6331 Hünenberg

☎ +41 41 727 27 77

✉ [spannen@triag-int.ch](mailto:spannen@triag-int.ch)

✉ [clamping@triag-int.ch](mailto:clamping@triag-int.ch)



**swissmodular.com**  
Official Website



Langfristige Kundenbeziehungen  
*Long-term customer relations*

Lehrlingsausbildung  
und faire Lohnpolitik  
*Apprenticeship and  
fair wage policy*

Respektvolle Teamarbeit  
*Respectful teamwork*

**swiss**   
**MODULAR**<sup>®</sup>  
by Triag International AG

Erstklassige Qualität  
zu fairen Preisen  
*First class quality  
with fair pricing*

Wir respektieren unsere Umwelt  
*We respect our environment*



Time to say goodbye  
to the dinosaur vises!



# SECRETS OF

## RAUM SPACE

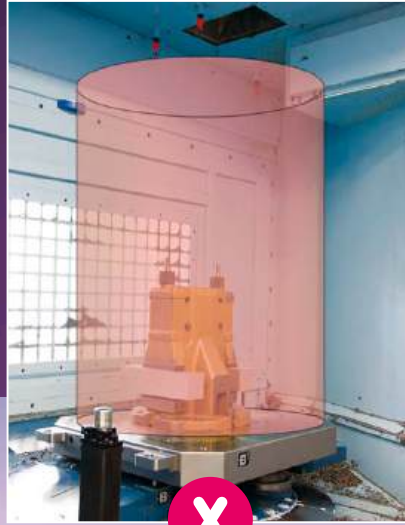

«In Gebäuden ist es üblich, den Raum komplett zu vermieten. Wieso nicht auch in Ihrer Maschine?»

«In buildings, it is common to rent out the full space. Why not in your machine?»

## ZEIT TIME

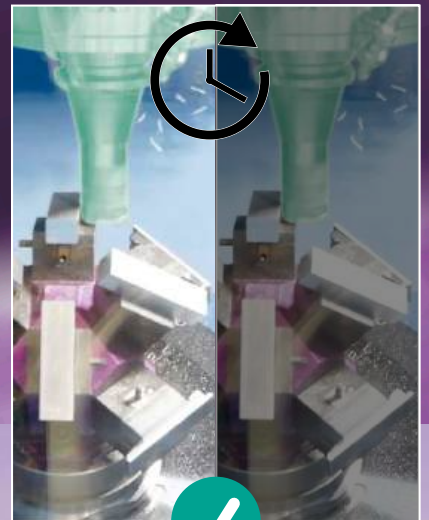

«Flugzeuge sollen möglichst kurze Zeit geparkt bleiben. Das gleiche gilt für die Frässpindel.»

«Aircrafts should remain parked for the shortest amount of time. The same rule applies to the milling spindle.»



## MIXED PRODUCTION



## AUTOMATION

«Eine durchdachte Automation ist unverzichtbar. Sie soll 24/7 unbemannte Produktion und lange Spindellaufzeiten ermöglichen.»



«A smart automation is essential. It should enable 24/7 unmanned production and long spindle running times.»

«Modular» bedeutet:

### 3 dimensionales Anpassen an Werkstück und Maschine

## Vorteile des modularen Mehrfachspannens:

- Möglichkeit der chaotischen Produktion
- Schneller Werkstückwechsel
- Vielseitigkeit durch Kombination mehrerer Komponenten, 3D modular (Schienen, mechanisch oder hydraulisch betätigte Spannelemente etc.)
- Einfache Montageprozesse
- Lange Lebensdauer, geringe zusätzliche Instandhaltungskosten
- Beschädigte Komponenten können einfach ersetzt werden
- Längere unbemannte Laufzeit
- Deutlich weniger Werkzeug- und Palettenwechsel
- Schont die Maschine, da der gesamte Bearbeitungsraum genutzt wird
- Preis: Kann trotz der Vorteile mit einem Spannstock mithalten
- Geringerer Aufwand in der Logistik, Lagerhaltung und Beschaffung
- Höhere Spanndichte, mehr Teile aufgespannt
- Spannen von kleinen wie grossen Werkstücken

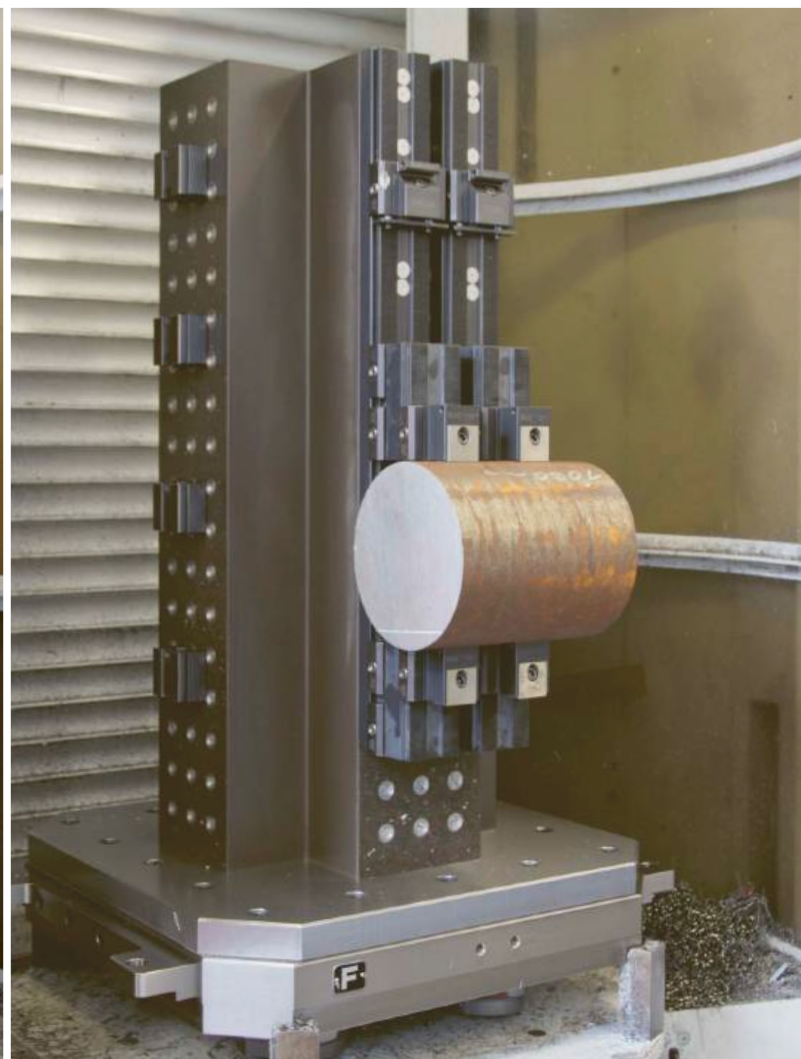
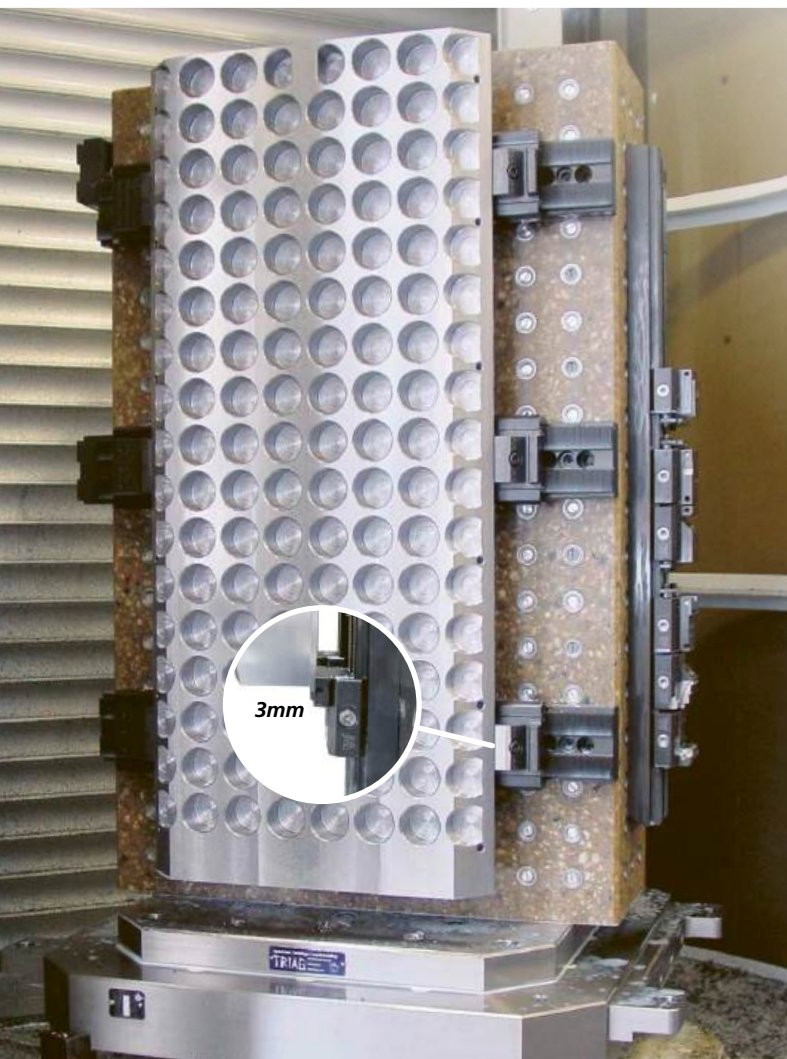

«Modular» means:

## ***Adapting to workpiece and machine situation in 3 dimensions***

### ***Advantage of modular workholding:***

- Possibility of chaotic manufacturing
- Fast workpiece change
- Flexibility because of different components, 3D modular
- Simple to set up
- Cost effective
- Easy to replace spare parts
- Long unmanned production
- Less tool changes
- The machines are used in the whole working area
- Competitive price to standart vises
- Simple to be purchased and used on different machines
- High density workholding, you clamp more parts!
- Long and reliable live with low maintenance cost

Chaotische Spannung für das Erledigen von verschiedenen Jobs gleichzeitig.  
Optimale Nutzung eines Horizontal-Bearbeitungszentrums.

*Mixed set up on a Mazak horizontal machine with  
18 pallets. This is used for unmanned production of  
small quantities of different materials.*

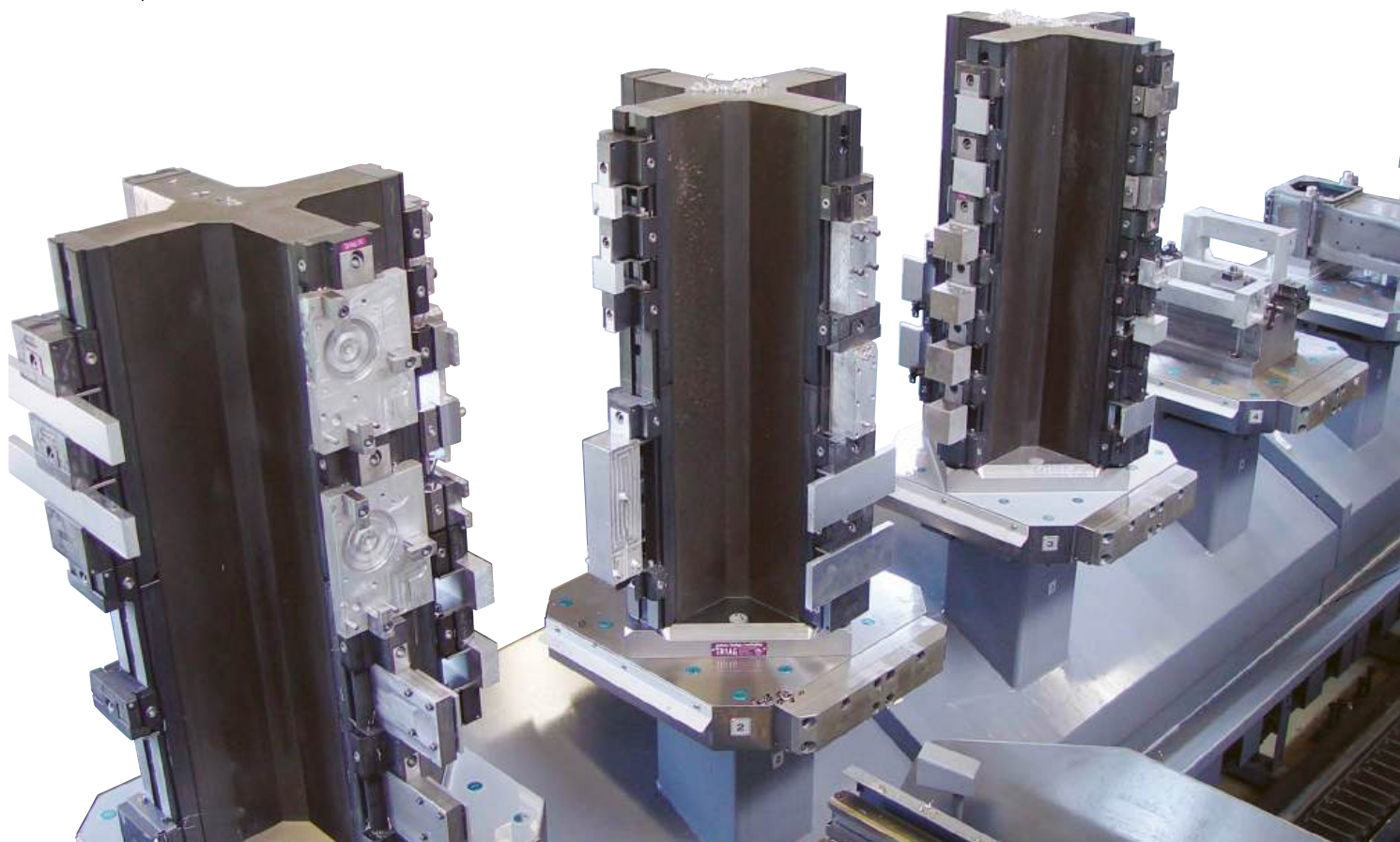

Modulare Mehrfachspannsysteme werden in ihrer Bedeutung für die Zerspanung noch immer unterschätzt. Dabei sind sie sowohl in der Einzelteilfertigung als auch für Grossserien flexibel einsetzbar. Zurückzuführen ist diese Flexibilität auf das Konstruktionsprinzip der Systeme, ihre handhabbare, kompakte Bauweise wie auch die hohe Spannkraft und Spanndichte.

Bei der Beurteilung modularer Mehrfachspannsysteme gibt es eine eigentümliche Konstellation: Zum einen sieht der Einzelteil- und Kleinserienfertiger enorme Vorteile für die Anwendung in der Serienfertigung, beispielsweise rückbaubarer Vorrichtungsbaukasten. Zum anderen erkennt der Serienfertiger genau diese Vorzüge für die Einzelteil- und Kleinserienfertigung. Diese Sichtweise zu hinterfragen und zu verdeutlichen, worin die fertigungsspezifischen Vorteile modularer Mehrfachspannsysteme liegen, ist Ziel des Beitrags.

## Modulare Mehrfachspannsysteme sind flexibel anwendbar

Für viele Zerspanungsarbeiten ist der klassische Maschinenschraubstock auch heute noch die passende Spannung. Mit den ständig neuen und erhöhten Anforderungen geht allerdings die Entwicklung der Spanntechnik in eine andere Richtung. Will man ein hohes Mass an Flexibilität und eine grosse Spanndichte erzielen und sollen gleichzeitig verschiedene Werkstücke auf kleinstem Raum gespannt werden, kommt der klassische Maschinenschraubstock oft an seine Grenzen. Häufig führt hier nur ein modulares Mehrfachspannsystem zum Erfolg. Spannsysteme müssen heute möglichst flexibel sein. Damit lassen sie sich an veränderte Umstände anpassen und können so die Wirtschaftlichkeit des Bearbeitungsprozesses erhalten. Modular ist ein Spannsystem, wenn es nach dem Baukastenprinzip aus Elementen zusammengesetzt und erweiterbar ist. Neben diesen grundsätzlichen Eigenschaften bedarf das Spannsystem jedoch weiterer prägnanter Merkmale: So muss es einfach und schnell zu handhaben sein, eine kompakte Bauweise mit hoher Spannkraft und Spanndichte verbinden und möglichst autarke Spannstellen aufweisen, deren Spanndruck einzeln zu verstellen ist. Im Idealfall kann mit nur einer Basisschiene ein breites Backenprogramm mit geringem Aufwand aufgebaut werden.

In der Serienfertigung besteht der wohl grösste Vorteil modularer Mehrfachspannsysteme darin, dass sich das System als rückbaubarer Vorrichtungsbaukasten für ein vielseitig gefächertes Werkstückspektrum einsetzen lässt. So spart sich der Anwender oft teilespezifische, teure Vorrichtungen. Mehrfachspannsysteme können zudem das Engineering vereinfachen, da sich auf vorhandenes Spannmateriale zurückgreifen lässt. So sind kurze Planungs- und Umrüstzeiten realistisch. Darüber hinaus trägt das modulare System zur erhöhten Prozesssicherheit bei und fördert die Qualitätstreue, die heute ein elementares, unabdingbares Kriterium der modernen Fertigung ist. Schliesslich ist ein Mehrfachspannsystem mit mehreren unabhängigen Spannstellen auch für den Einsatz in der Serie ideal, da so mehrere Werkstückspannungen mit unterschiedlichen Parametern möglich sind.

## Anwendung ist bei horizontalem und vertikalem Aufbau möglich

Häufig wird bei der Serienfertigung eine Maschine mit horizontalem Aufbau, Palettenbahnhof und Spanntürmen verwendet. Was aber ist mit vertikalen Bearbeitungszentren? Wo liegen hier die Vorteile eines Mehrfachspannsystems? Spanntürme, die in der Serienfertigung mit modularen Mehrfachspannsystemen bestückt werden, weisen eine hohe Spanndichte auf, die zur verlängerten Spindelzeit führt. Gleichzeitig ist auch eine hervorragende Zugänglichkeit der Werkzeuge gewährleistet.



1

## Vertikalmaschinen, deren komplette Tischflächen mit einem modularen Mehrfachspannsystem bestückt sind, ermöglichen Spanndichten, die denen auf Horizontalmaschinen gleichen

Mit einer vierten Achse kann eine Vertikalmaschine zur Serienmaschine mit Mehrseitenbearbeitung aufgerüstet werden, wobei auch hier eine hohe Spanndichte und Zugänglichkeit erreicht wird. Die horizontale und die vertikale Strategie lässt sich mit dem gleichen Spannsystem umsetzen, was bei Maschinenausfall mitunter eine echte Problemlösung darstellt.

## Autarke Spannstellen sind auch für die Kleinserie wichtig

In der Einzelteil- und Kleinserienfertigung spielen modulare Mehrfachspannsysteme grundsätzlich die gleichen Vorteile wie in der Serienfertigung aus: hohe Spanndichte, geringere Werkzeugwechselzeiten, bessere Tischauslastung, gute Zugänglichkeit, einfache Handhabung, einfaches Engineering. Besonders wichtig ist hier jedoch die Flexibilität der Spanntechnik. Gerade bei kleinen Losgrößen geht viel Zeit beim Umrüsten verloren. Um diesen Vorgang zu optimieren, ist der Einsatz modularer Spannsysteme häufig das einzige Mittel. Daher ist die schnelle Verstellbarkeit der einzelnen Spannstellen in Spanndruck, Backenbreite oder Backenausführung unabdingbar.

Autarke Spannstellen sind gerade für den Einzelteilfertiger immens wichtig. Mit ihnen kann er sicherstellen, dass sich verschiedene Werkstücke aus unterschiedlichen Materialien gleichzeitig und prozessspezifisch spannen lassen (siehe Bild 2).

Der notwendige Spanndruck wird dabei ebenso gewährleistet wie die Verformungsfreiheit des Werkstücks. Letztlich resultiert aus der höheren Spanndichte eine längere Spindelzeit. Bei wiederkehrenden Kleinserien ist die reproduzierbare Spannsituation sehr wichtig. Wie in der Grossserie kann auch bei Kleinserien oder Einzelteilen die Tischfläche mit einem Mehrfachspannsystem besser ausgenutzt, der Werkzeugwechsel reduziert und die Wirtschaftlichkeit erhöht werden (siehe Bild 3).

Bei genauer Betrachtung der verschiedenen Fertigungsstrategien - Horizontal- oder Vertikal-BAZ sowie Serien-, Einzelteil- oder Kleinserienfertigung- wird die Vermischung der Verfahren deutlich. Die vermeintlichen Unterschiede sind oft nicht gross. Auch ist die Investition, die beim Übergang von einer Strategie zur anderen notwendig wird, jederzeit vertretbar und zu argumentieren. So erweist sich beispielsweise eine hochwertige Spannschiene mit drei oder vier Spannstellen als weitgehend preisneutral zu einem klassischen Maschinenschraubstock.

Für viele Anwendungen sind modulare Mehrfachspannsysteme ein echter Problemlöser und daher unumgänglich. Dies gilt sowohl für den Einsatz in der Serie als auch in der Einzelteilfertigung. Insofern haben beide Anwender - um zum Anfang zurückzukehren - mit ihrer Sichtweise recht. Nur gelten die Vorteile eben nicht nur für den jeweils anderen Bereich, sondern vor allem auch für den eigenen.

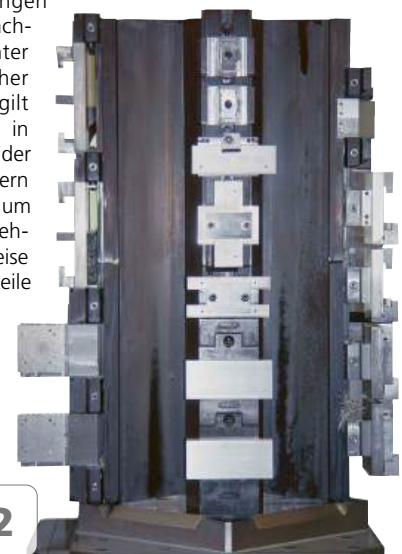

2

**Kleinserienfertigung auf Horizontalmaschinen: Autarke Spannstellen ermöglichen die gleichzeitige, spezifische Fixierung unterschiedlicher Werkstücke.**

*Small batch production of different work pieces on a horizontal machining centre (family of parts)*

# The dormant potential

From the press

Modular and multiple workholding systems are still underestimated in their economic potential. But they have proven their point in many practical applications in batch production, in some cases even on small series. This is due to their modular, compact design resulting in a very high workpiece density. In spite of their compact size, the clamping force is considerable. Producers of small batches see the advantages of these systems mainly in the quantity production, whereas the mass producer uses these modular vice elements on some occasions to quickly set up a fixture for only a few parts. The reason for this fact you will find in this editorial.

## Modular workholding systems are very flexible in their use

For many machining applications the classical machine vice is still the suitable workholding solution. Since the introduction of the CNC machining centres the demand for flexible, modular systems has constantly increased. These systems allow the accommodation of many parts in a limited workspace. Also the number of tool changes are considerably reduced, which means less machining time per part and longer spindle time between the loading stops. Consequently the machine productivity goes up.

Modern multiple workholding systems must be flexible. The setting up of their modules must be simple and quick. The kit like components have to be adaptable to many different workholding configurations, just by placing them into other locations or changing jaws. Their clamping force must be adjustable to protect the workpiece. In the ideal case the base rail must be able to accommodate many different vice modules and jaws.

In the production of larger batches the modular workholding systems have the greatest advantages. Their interchangeable modules can be placed to suit the workpieces often replacing expensive dedicated fixtures. Engineering of fixtures may be simplified.

Hence planning and set up from one part to the next can be shortened. Multiple workholding systems contribute also to more constant and precise parts improving the interchangeability of products, an important criterion in today's industrial world. In some cases it is even possible to clamp a family of parts in one setup. Some of our customers take advantage of this feature.

## Installation possible on horizontal and vertical machines

On horizontal machines tombstones (fixture carrying towers) are often installed on the pallets. This arrangement allows for machining on three faces even with very high workpiece density. What about machines with vertical spindles? Where are the advantages of multiple workholding

systems on such machines. The machine table can be filled with several workholding systems side by side allowing many parts to be clamped in a small area. If an indexer (fourth axis) is installed with a bridge or a trunnion exactly the same machining features are possible as on a horizontal

**The output of a vertical machine with a fully loaded table surface is similar to that of a horizontal machine.**

machines – lots of parts even when machining on three faces. If independent base rails are used they can be installed vertically as well as horizontally. A high interchangeability of components gives good flexibility in case of a machine break down.

## Multiple workholding also for small batch production and families of parts

A very important advantage besides the points mentioned for large quantity production, is the workholding of part families, particularly if the parts are produced at intervals. In such cases the flexibility and the simplicity of set up is of great importance. For instance shaped jaws may be stored in the tool room ready for the next production run. In some applications users build dedicated fixtures and install Compact Clamp or microCLAMP vice modules on their own fixtures (see picture 2).

Naturally the rail based systems like the Power Clamp or the Compact Clamp can be used as a conventional vice if only one vice module and one end module is used. For wider workpieces sometimes two or more systems are installed side by side. Doing that, the vice modules and the reference surfaces are aligned by the serrations or the pins in the base rail.

Again, the clamping of different workpieces allows the use of the same tool on various cuts therefore giving longer machining cycles and less tool changes (see picture 3).

The investment in a multiple workholding system with three or four workholding stations is about the same as that for a conventional machine vice. But the multiple workholding system gives the user much greater flexibility and versatility.



**Die Verwendung von Mehrfachspannsystemen auch in der Kleinserienfertigung reduziert den Werkzeugwechsel und erhöht die Wirtschaftlichkeit.**

**The use of a multiple workholding system is also beneficial in small batch machining.**

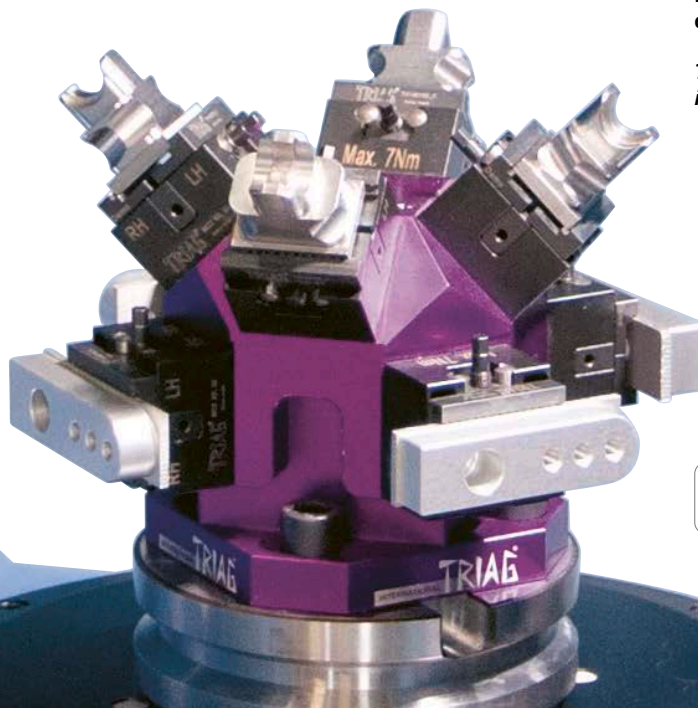

**Mehrfachspannung auf spaceGRIP 1  
Multiple workholding on spaceGRIP 1**

## WIE? HOW?

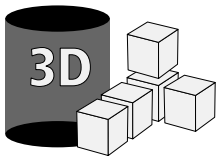

**3D-Modularität  
für eine optimale  
Raumnutzung**

*3D-Modularity for  
an optimal use of  
space*

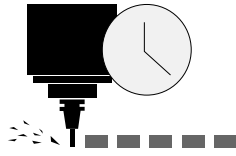

**Mehrfachspannung  
für weniger  
Maschinenstandzeit**

*Multiple workholding  
for less machine down  
time*



**Chaotisches Spannen für  
das Erledigen von verschie-  
denen Jobs gleichzeitig**

*Mixed clamping for the  
manufacturing of different  
jobs at the same time*

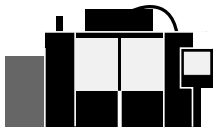

**Grundvoraussetzung:  
Zuverlässige Maschine mit  
ausreichenden Werkzeug  
und Paletten Plätzen und  
eine geeignete Automati-  
sierungsmethode**









**Basic requirement:  
Reliable machine with suf-  
ficient tool an palett places  
and a suitable automati-  
sation method**



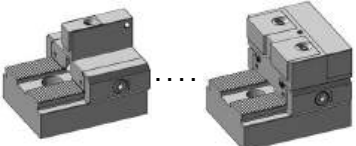
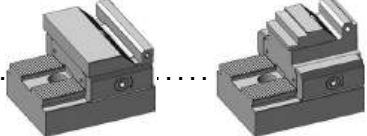

# *power*CLAMP & *5axes*

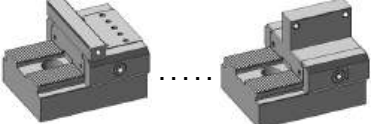

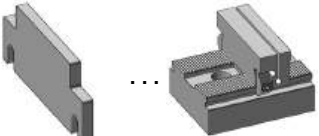
	Einleitung   <i>Introduction</i> .....	15 - 21
	Bedienungsanleitung   <i>Operating manual</i> Spannkraft und Drehmoment   <i>Workholding force and torque</i> .....	22
	Anwendungsbeispiele   <i>Examples of application</i> .....	23 - 38
	System - Basisschiene   <i>System - base-rail</i> .....	 41 - 57
	Modular - Startersets   <i>Modular - Starter kit</i> .....	 58 - 59
	Niederzugspanmodule   <i>Pull down clamp modules</i> .....	 60 - 73
	Linearspannmodule mit Präge- und Linearbacken <i>Linear clamping modules with stamping and linear jaws</i> .....	 74 - 83
	Backen zu Linear   <i>Jaws for linear</i> .....	 82 - 84
	Anschlagmodule   <i>End module</i> .....	 85 - 92
	Verschiedene Module   <i>Different modules</i> .....	 93 - 105
	Zubehör   <i>Accessories</i> .....	 106 - 112

# Warum modular Spannen Why modular workholding

powerCLAMP

Der klassische Maschinenschraubstock ist für gewisse Zerspanungsarbeiten vielfach die richtige Wahl, obwohl man einen Spannstock ohne Mehrkosten auch mit einem Modularesystem aufbauen kann. Er wird durch die ständig erhöhten Anforderungen an die Prozessoptimierung immer mehr durch modulare Spannsysteme ersetzt.

*The classic machine vise is for some application still a good option, on the other hand can you set up the same with a modular clamp system at not higher costs! Because of always increasing demand and high competition you see more modular systems at endusers places, to keep up with productivity.*

Mit den modularen Systemen wird ein hohes Mass an Flexibilität und grosser Spanndichte erreicht. Dies führt auch bei der Einzelteil- und Kleinserienfertigung zur Senkung der kostenintensiven Nebenzeiten, die einen wichtigen Faktor in der Wertschöpfungskette darstellen. Gegenüber Vorrichtungen ist der Vorteil, dass bei einem modularisiertem Aufbau die Aufspannung aus einem Baukastensystem (also standardisierten Einzelbauteilen) besteht, die kostengünstiger sind und für andere Aufspannungen wiederverwendet werden können. Zudem wird für die 3-Seitenbearbeitung eine gute Zugänglichkeit zum Werkstück gewährleistet.

*With modular clamp system you achieve a high flexibility and also high density of holding workpieces. This brings you big advantages also by producing single parts or small quantities! Compared to dedicated fixtures you can use this vises for many different applications.*

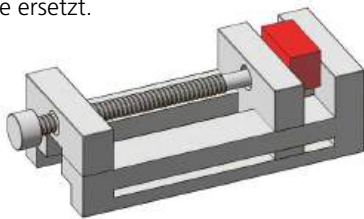

Spannen mit dem Spannstock  
Clamping with the machine vise

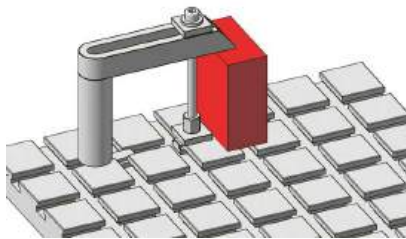

Spannen mit Spannpratzen  
Clamps in operation

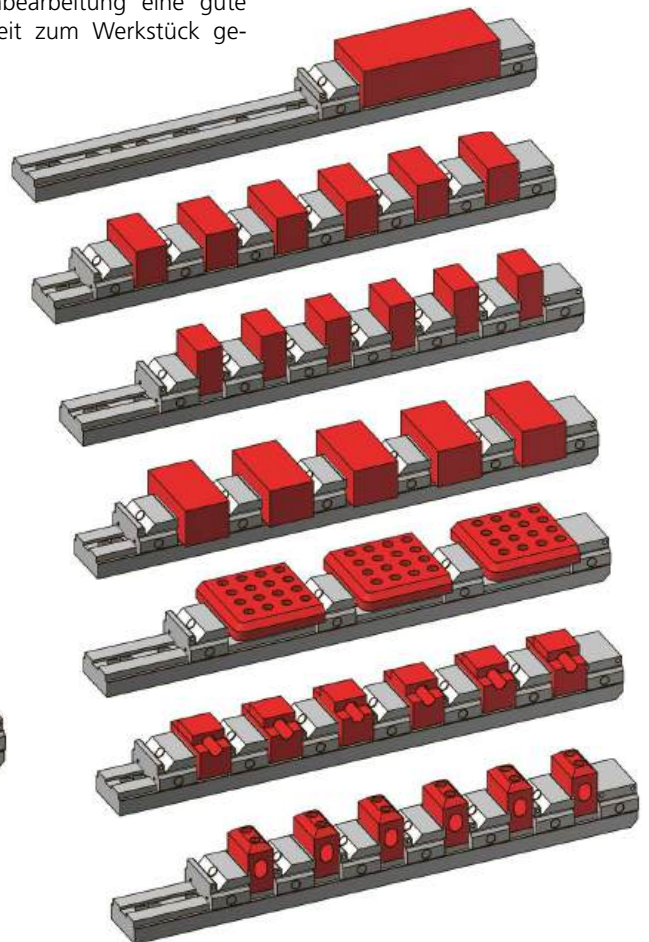
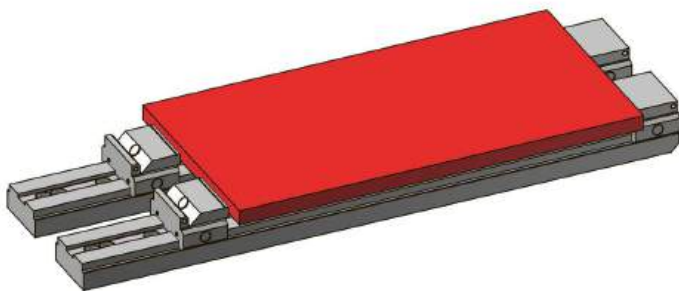

## Ausserdem / And:

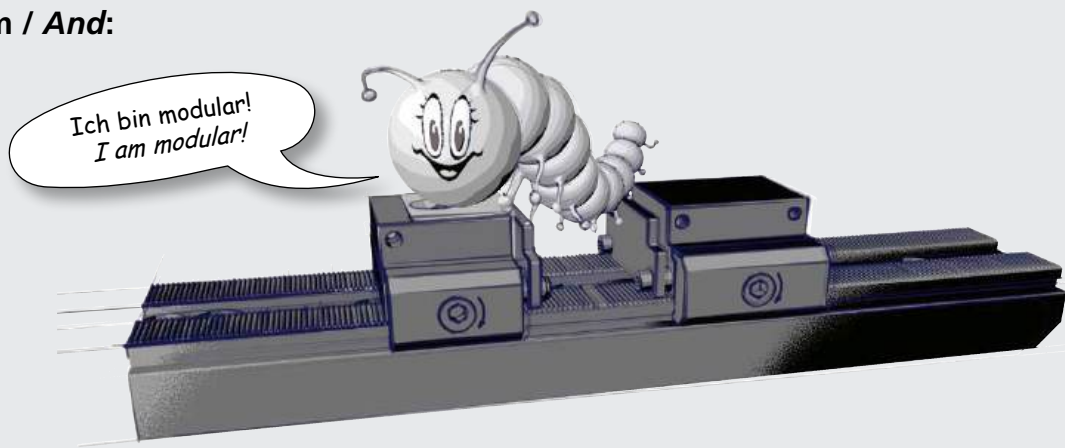

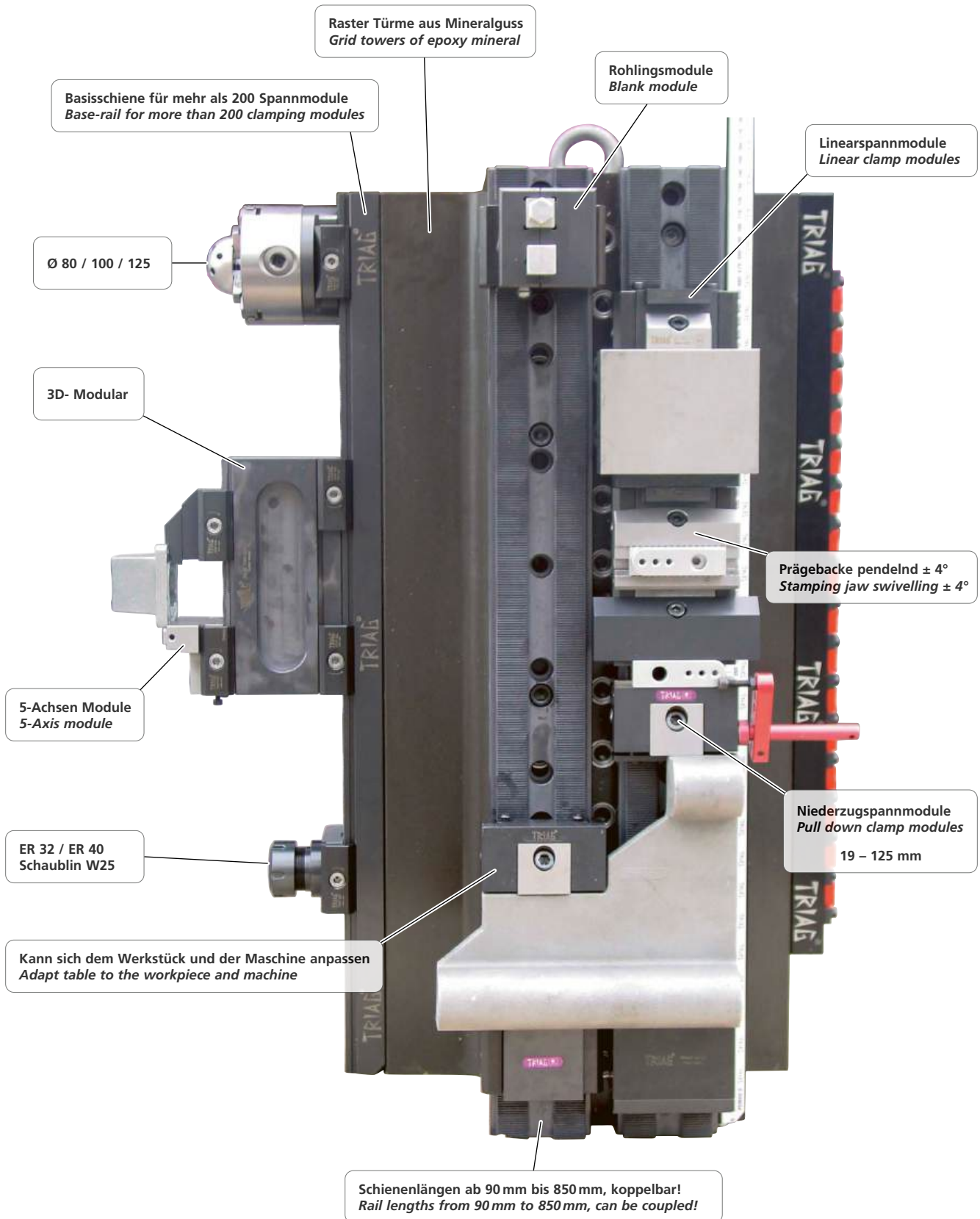

**Modulares Spannen =** Einzelspannung, Mehrfachspannung sowie auch das Spannen von kleinen, grossen oder unförmigen Werkstücken.  
Chaotisches, gemischtes spannen!

**Modular workholding =** Single clamping, multiple clamping small parts and large workpieces can be clamped, also shaped parts are possible to clamp.  
Mixed setups in chaotical clamp situation!

Mit dem Spannsystem Power Clamp hat die Triag International ein Produkt entwickelt, welches die Vorteile des klassischen Maschinenschraubstocks mit der Modularität eines innovativen Spannsystems in einer optimalen Art und Weise kombiniert und eine enorme Vielseitigkeit bietet. Einfache Spannungen sind genauso möglich wie Mehrfachspannungen und Spannungen von schwierigen Werkstücken.

*With Power Clamp Triag has developed a product which includes the advantages of a classical vise and has the features of an advanced modular system. It can be used to clamp single parts (small and big) or multiple workholding as well as difficult to clamp parts.*

## Schnelligkeit / Quickness



1

**Eine Schraube lösen**  
*Loosen a screw*



2

**Abheben und neu platzieren**  
*lift and change position*



3

**Eine Schraube anziehen**  
*fasten one screw*

Mit nur einer Schraubspindel, welche von beiden Seiten her zugänglich ist, werden die positionierten Module in einem patentierten Pratzensystem zuverlässig geklemmt.

Die Module können an jeder Stelle der Trägerschienen aufgesetzt werden. Verglichen mit dem üblichen axialen Aufschieben beschleunigt das den Aufbau von Mehrfachspannern und ermöglicht, diese Spannsysteme auch bei beengten Platzverhältnissen komfortabel zu rüsten.

*With only one bolt screw (left and right hand thread) the clamp modules can be lifted and change position in 2mm steps.*

*This patented system is unique and fast, as well as accurate.*

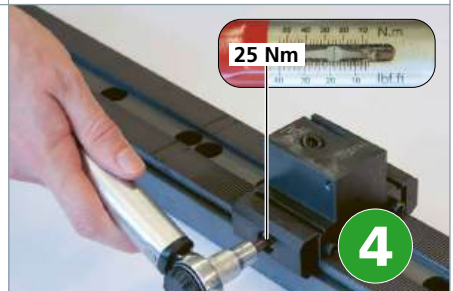

4

**Drehmoment beachten**  
*Observe the torque*

## Geringes Gewicht Low weight



**= Einfaches Handling**  
**= Easy handling**

Das Modul kann mit zwei Fingern abgehoben werden.  
*The clamp module can be moved by two fingers.*



## Einfache Reinigung Easy cleaning



Keine spänefüllenden T-Nuten (im Gegensatz zu vielen Wettbewerbsprodukten) - Basis bilden stabile, mit Teilstücken verlängerbare Trägerschienen. Sie verfügen über eine hochgenau gefräste Verzahnung.

Eine Vielzahl an Spannmodulen mit unterschiedlichen Spannelementen lassen sich auf den Trägerschienen in einem Raster von 2 mm positionieren.

*No chip catching T-slots (opposite of many competitors). The base rails are rigid and can be used modular in length width and height. The serration is accurate and checked for each base rail.*

*Many different clamp modules can be used on only one type base rail (step 2 mm)*

# Basisschienen / Base rails

Masssystem / Measurement system = metric & inch **powerCLAMP**

90 mm

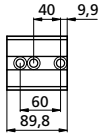

125 mm

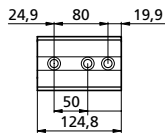

220 mm

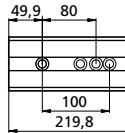

250 mm

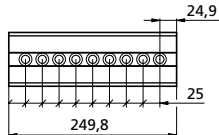

350 mm

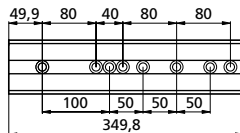

400 mm

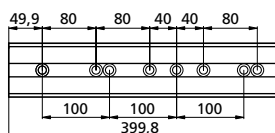

450 mm

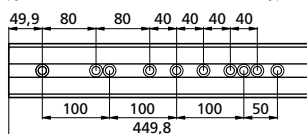

500 mm

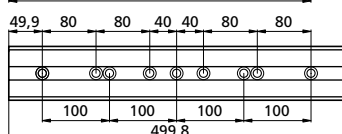

550 mm

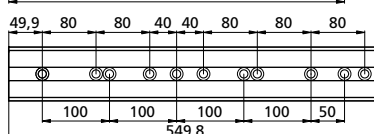

600 mm

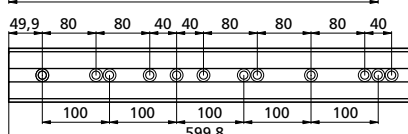

650 mm

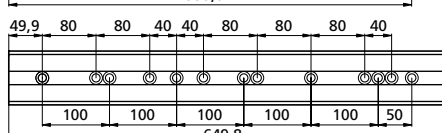

700 mm

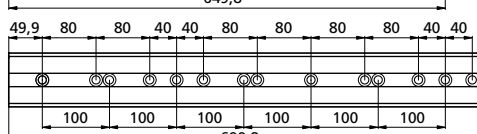

750 mm

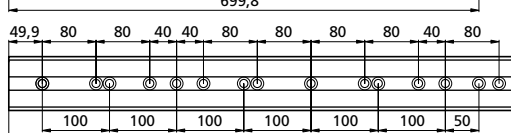

800 mm

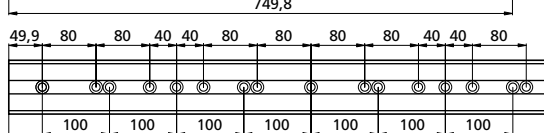

Schienen sind in den folgenden Höhen lieferbar:  
Rails are in following ups available:

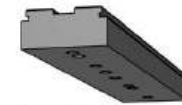

➔ 35 mm

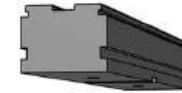

➔ 60 mm



➔ 80 mm



➔ 175 mm

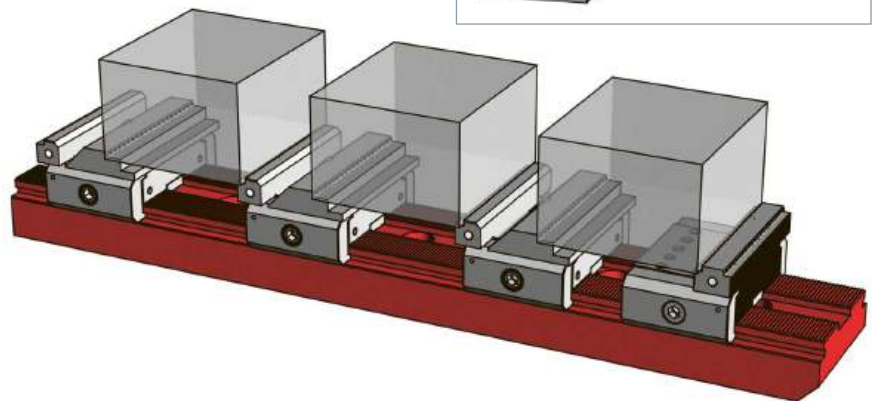

## Basisschiene

Die Basisschiene ist das Grundelement des modularen Spannsystems von Triag International und ist in den Höhen 35 mm, 60 mm, 80 mm und 175 mm verfügbar. Auf der Basisschiene werden alle Spann- und Anschlagmodule über eine Schraubspindel mit einer Haltekraft von 15.000 daN (= 15 t) befestigt. Eine schnelle und genaue Positionierung ist durch die Verzahnung (2 mm Teilung) auf der Basisschiene gewährleistet und sorgt somit für kurze Rüstzeiten.

Durch den Einsatz von Erhöhungsmodulen wird die Werkstück-Zugänglichkeit speziell bei 5-Achsenmaschinen auch mit kurzen Werkzeugaufnahmen ermöglicht. Somit ist die Maximalgröße der Werkstücke nur noch durch die Maschinengröße eingeschränkt. Die Basisschiene dient in diesem Zusammenhang als mechanisches Nullpunktsystem.

Die Basisschienen sind für eine schnelle Aufspannung auf den gängigsten Palettsystemen konzipiert. Aus Gewichtsgründen können auch die eigens entwickelten Spanntürme aus Mineralguss eingesetzt werden. Diese verfügen über eine so hohe Vibrationsdämpfung, dass dadurch im oberen Bereich der Türme sehr präzise gearbeitet und dabei eine exzellente Oberflächengüte erreicht werden kann.

# Basisschienen / Base rails

Masssystem / Measurement system = metric & inch powerCLAMP



Mit verschiedenen Basismodulen kann man auch die 3. Dimension Modular gestalten! Mit der Höhe von 60 mm kann die Modulhöhe auf 94 respektive auf 109 mm erhöht werden (34/49 Modulhöhe). Die Länge von 130 mm erlaubt es jeweils ein Spannmodul und ein Anschlagmodul zu platzieren.

There are different sizes of riser blocks to increase the height of the clamp modules. This way you can get from 34 to a clamp height of 94 or 109 mm depending on the clamp module you choose. This riser blocks makes the power clamp system 3D-modular!

**Mehr auf Seite | More on Page 48**

## Base rail

The base rail is the basic element of the Triag modular clamp system. We offer them in different lengths and heights and more than a hundred different standard clamp modules will fit onto the base rails.

Holding force which the clamp modules are clamped to the base rail is 15'000 daN (15t). The precision serration in 2mm pitch allows to fit the clamps fast and accurate.

All three dimension are modular! You can double or triple the length with coupling the rails or you can use them side words in a row. Also the height is modular (please see next page)



Basisschienen in Zoll  
Base rails in inch



#### Das Anschlagmodul / End modules

Für das Spannsystem «Power Clamp» ist in der Regel nur ein Anschlagmodul als «feste Backe» notwendig. Mittels der 2 mm Verzahnung lässt sich das Modul sehr genau auf der Basisschiene positionieren und ist mit der Schraubspindel schnell befestigt.

Für die unterschiedlichen Bearbeitungssituationen steht eine Vielzahl von Ausführungen zur Verfügung. Diese unterscheiden sich in der Breite der Backen (ab 19 mm bis max. 150 mm) als auch in der Beschaffenheit der Spannflächen (glatt, geriffelt, gerillt, hartmetallbeschichtet oder mit Prägeverzahnung, mit der direkt geprägt werden kann).

*In a row of parts there is usually one end module followed by the clamp modules. For all the different clamp situation we offer a wide range of different end modules from 19 mm to 150 mm.*

*Usually you have one side of the datum face flat and the opposite double serrated so you have two options in one. Also direct stamping end modules with a workholding step of 3 mm are available.*

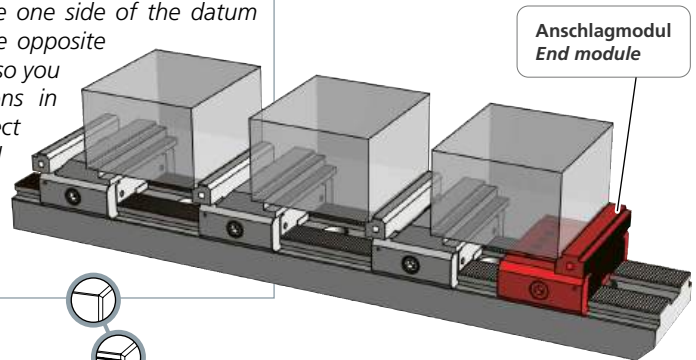

Anschlagmodul  
End module

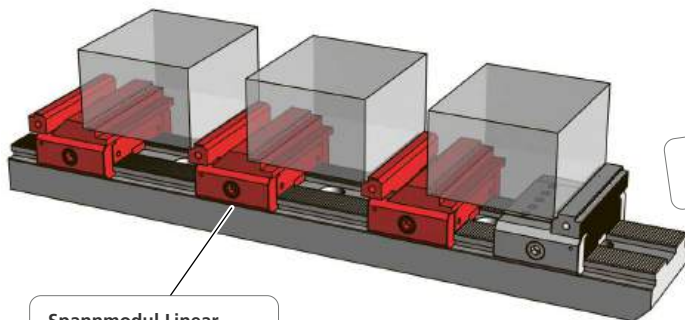

Spannmodul Linear  
Linear clamping module

Verschiedene Ausführungen der Anschlagflächen!  
Different styles at grip surfaces!



Lineare Direktprägespannung  
Linear direct stamping module

#### Das Spannmodul / Clamp modules

Die «beweglichen Backen» gibt es in zwei Ausführungen. Zum einen für das Niederzugspannsystem und zum anderen für das Linearspannsystem. Dabei dient das Spannmodul bei beiden Systemen wiederum als Anschlagmodul für die nächste Aufspannung.

Die Breite der Spannfläche bewegt sich wie bei den Anschlagmodulen im Bereich zwischen 19 mm und 125 mm. Durch die innovativen Ausführungen der Spannflächen wie z. B. die Prägebacken oder Druckstifte werden enorme Haltekräfte erreicht.

Bei umfangreichen Testreihen zu der Werkstückverschiebung bei einer Spannkraft von 2000 daN und einer Zerspankraft von bis zu 600 daN wurden bei der Verwendung von Prägebacken nur minimale Abweichungen vom Nullpunkt festgestellt. Leichte Abweichungen von der Parallelität der Werkstücke werden mit der Pendelfunktion ( $\pm 4^\circ$ ) ausgeglichen.

Innovative Lösungen gibt es auch für spezielle Spannaufgaben, wie z.B. Formbacken, Dreibacken- und Spannanzgenfutter, Vakuumplatten oder Magnetspannplatten.

*There are mainly two different types of clamp modules. Linear and pull down jaws both with integrated datum face for the next workpiece. Datum face can normally be double serrated or flat.*

*The movable jaws you can get in various versions such as hardened flat, carbide coated soft jaws double serrated, linear pull down, direct stamping dovating and more. The width of the clamps modules starts from 19 mm up to 125 mm.*

*Clamping force goes to a maximum of 2800 daN (2,8t).*

*For special clamping situations we offer also chucks, collet chucks vacuum plates or even magnet plates which fits onto the Power Clamp base rails.*

**Niederzugspanmodule  
Pull down clamp modules**

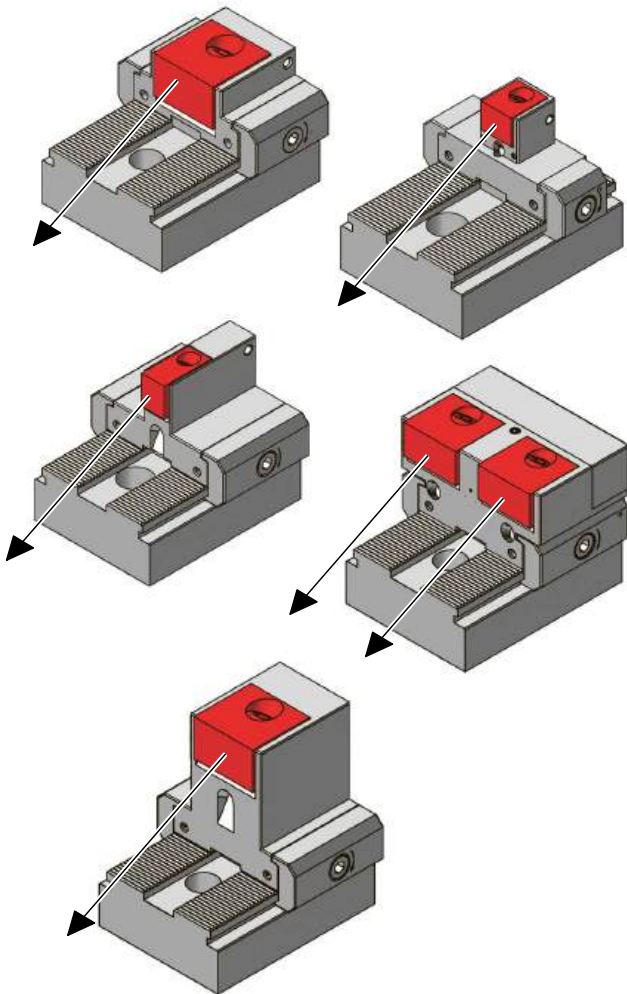

**Die Fakten beim Niederzugspannsystem**

Verstellbereich: 0- 4,1 mm  
Spannkraft: Bis 2'800 daN

**Vorteile beim Niederzugspannsystem:**

- Höhere Haltekräfte
- Hohe Wiederholgenauigkeit
- Optimale Spannmethode für Kleinteile
- Mit Schnellwechselbacken
- Doppelspannsystem in einer Backe zum Spannen und Bearbeiten von zwei Kleinteilen
- Mit Vorsatz als Linearspannsystem einsetzbar
- Auch Anschläge mit Niederzugeffekt erhältlich

**Facts for pull down clamp modules**

Jaw range: 0- 4,1 mm  
Clamping force: up to 2'800 daN

**Advantages pull down jaws:**

- Higher holding force
- With linear adaptable jaws
- Also with pull down jaws for the stop side available
- With adapter set can be changed to linear
- Also pull down jaws for datum face

**Linearspanmodule  
Linear clamp modules**

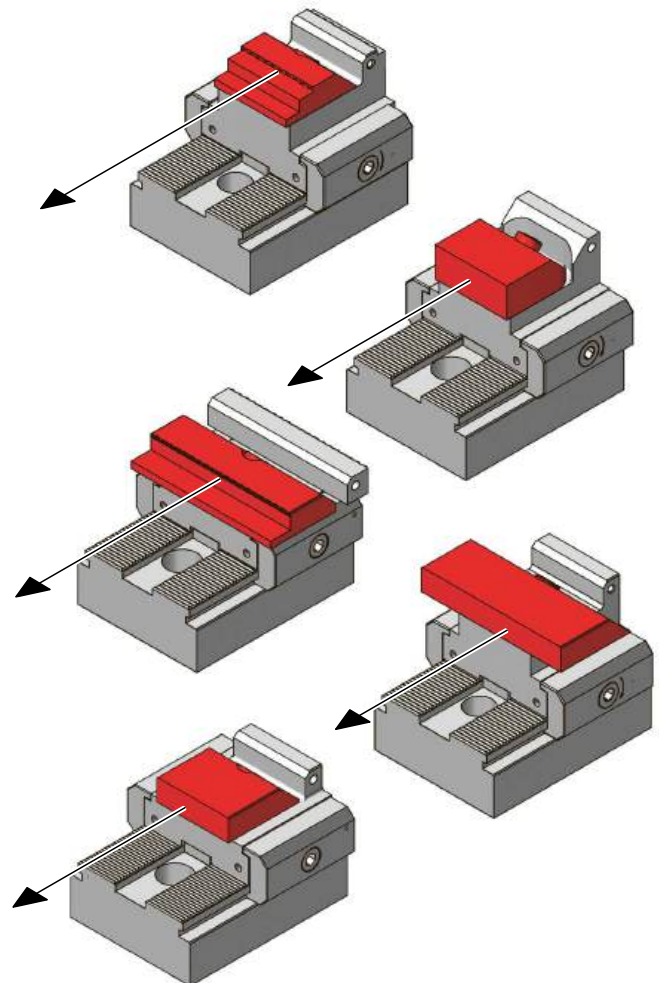

**Die Fakten beim Linearspannsystem**

Verstellbereich: 0- 5,0 mm  
Spannkraft: Bis 1'600 daN

**Vorteile beim Linearspannsystem:**

- Spannstockähnliches Spannen
- Prozesssichere Positionierung der zweiten Aufspannung
- Gut geeignet für die Erstellung von individuellen Formbacken
- Sicherer Halt mit Prägetechnik

**Facts for linear clamp modules**

Jaw range: 0- 5,0 mm  
Clamping force: up to 1'600 daN

**Advantages linear jaws:**

- Similar clamp as conventional vise
- Good for shaped jaws
- Secure clamped with direct stamping jaws
- Higher accuracy

### ACHTUNG / CAUTION

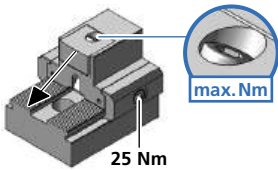

Niederzug Spannmodule  
Pull down module

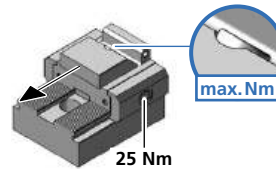

Linear Spannmodule  
Linear module



Schraube / Screw	Drehmoment / Torque		Spannkraft / Workholding force			
	Nm	(lb-ft)	~daN	~(lb)	~t	
M5 + M6	4	3	= 500	1100	0,50	
	5	3,7	= 580	1280	0,58	
	6	4,4	= 690	1520	0,69	
	7	5,2	= 780	1720	0,78	
	8	5,9	= 880	1940	0,88	
	9	6,6	= 980	2160	0,98	
	10	7,4	= 1020	2250	1,02	
	12	8,9	= 1220	2690	1,22	
	M6	14	10,4	= 1450	3200	1,45
		15	11	= 1520	3350	1,52
4		3	= 410	900	0,41	
M8	5	3,7	= 490	1080	0,49	
	6	4,4	= 560	1230	0,56	
	7	5,2	= 660	1450	0,66	
	8	5,9	= 730	1600	0,73	
	9	6,6	= 810	1790	0,81	
	10	7,4	= 900	1980	0,90	
	15	11	= 1520	3350	1,52	
	20	14,8	= 1810	3990	1,81	
	25	18,4	= 2100	4630	2,10	
	M10	10	7,4	= 400	880	0,40
20		14,8	= 1400	3090	1,40	
30		22,1	= 2000	4410	2,00	
40		29,5	= 2800	6170	2,80	

Schraube / Screw	Drehmoment / Torque		Spannkraft / Workholding force		
	Nm	(lb-ft)	~daN	~(lb)	~t
M8	10	7,4	= 400	880	0,4
	20	14,8	= 800	1760	0,8
	30	22,2	= 1200	2650	1,2
	40	29,6	= 1600	3530	1,6

**WICHTIG:** Die angegebenen Drehmomente sind die absoluten Maximalwerte. Über die Spannkraften geben die Tabellen Auskunft.

**IMPORTANT:** The torque numbers specified represent the absolute maximum. The table at the bottom of this page provides further information on the workholding forces.



**1** TWPAS 1240 (60 Nm)  
M12 x 40 (100 Nm)

**2**

**3**

**4**

**5**

~ 1-3 Nm

**6**

**7** **WICHTIG:** Vor dem Positionieren der Spannmodule für ein neues Werkstück, ist die **Spannbacke ganz zurück zu stellen**, dies gewährleistet eine sichere Spannung!

**IMPORTANT:** Prior to setting up a new clamping module the **clamping jaw of the vice module must be retracted all the way!** This guarantees proper clamping of the new workpiece.

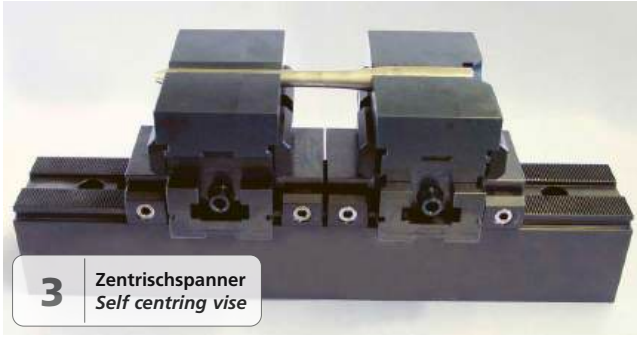
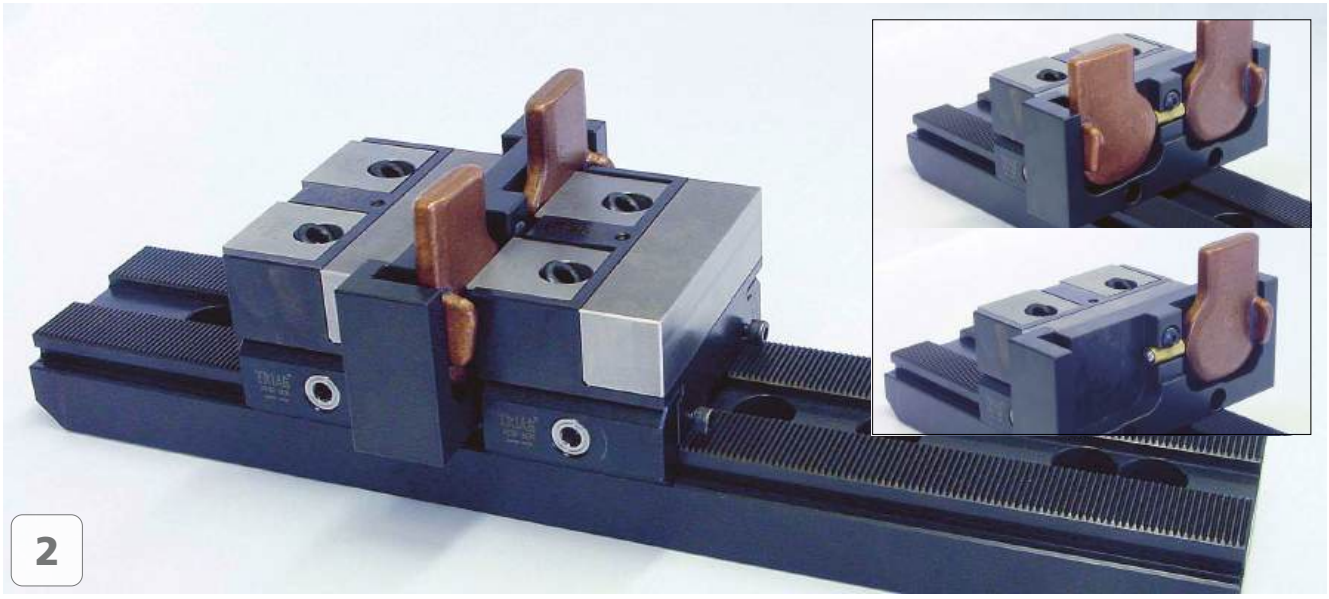
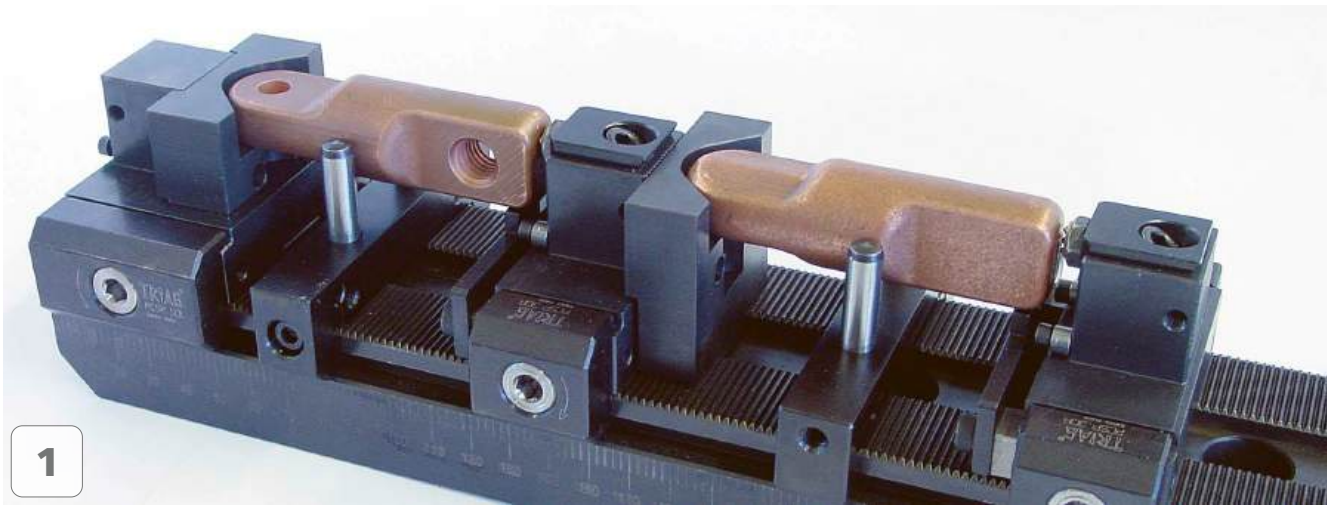

Zentrischspanner  
Self centring vise

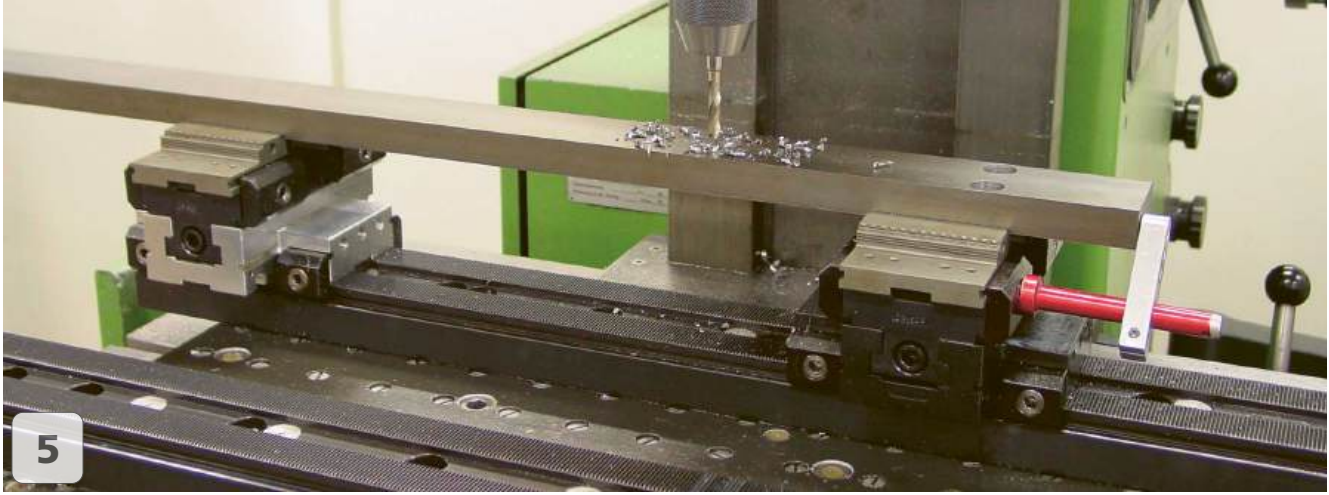
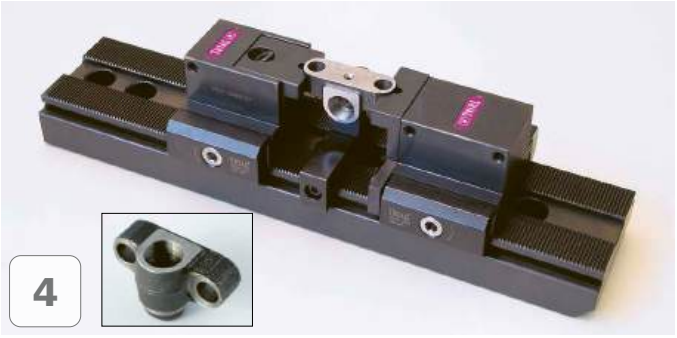

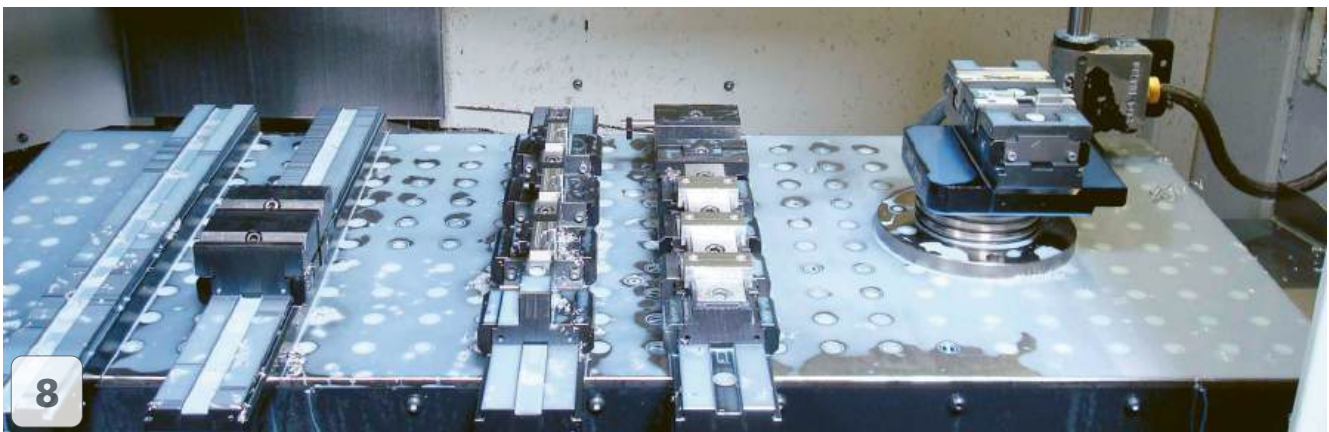
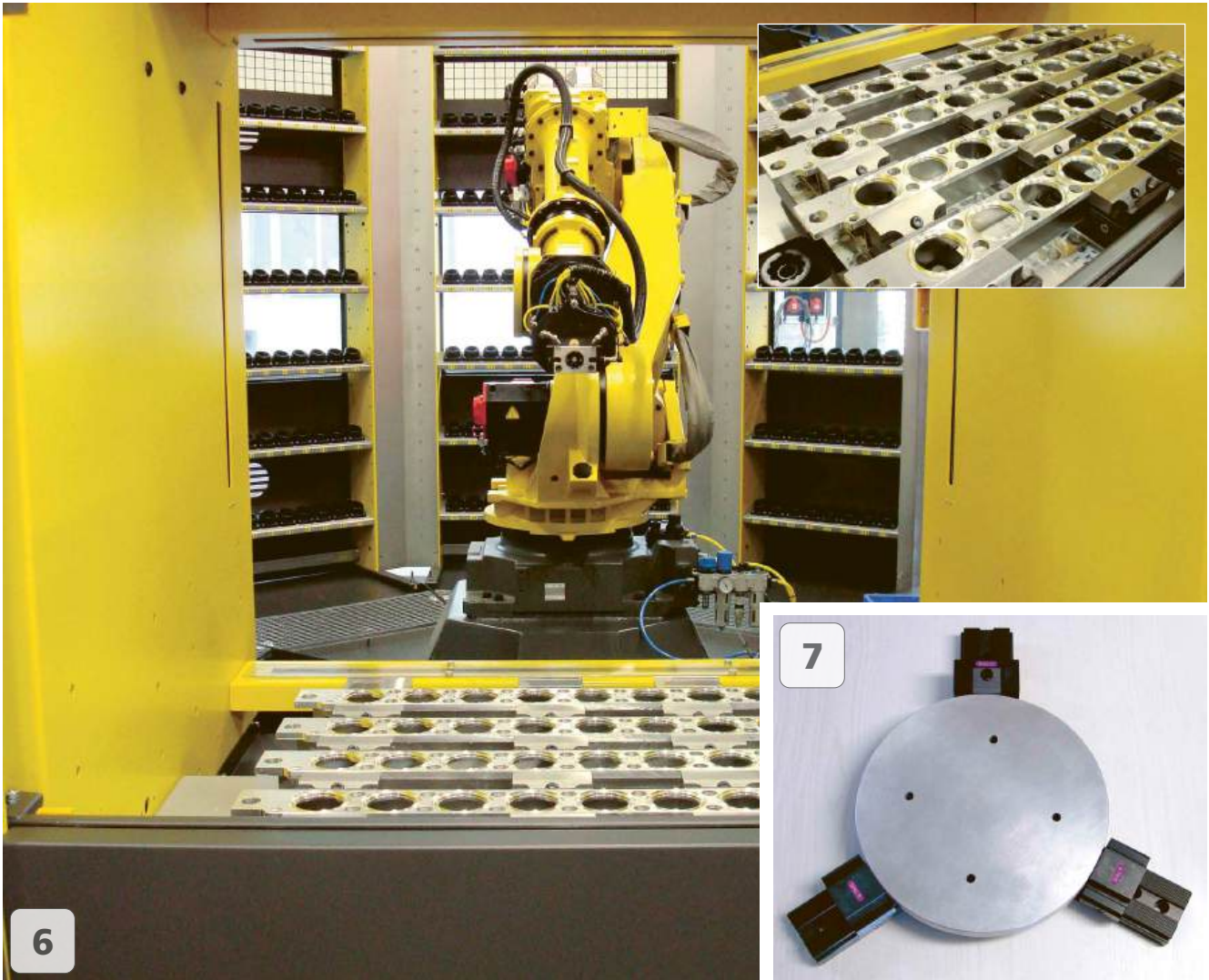

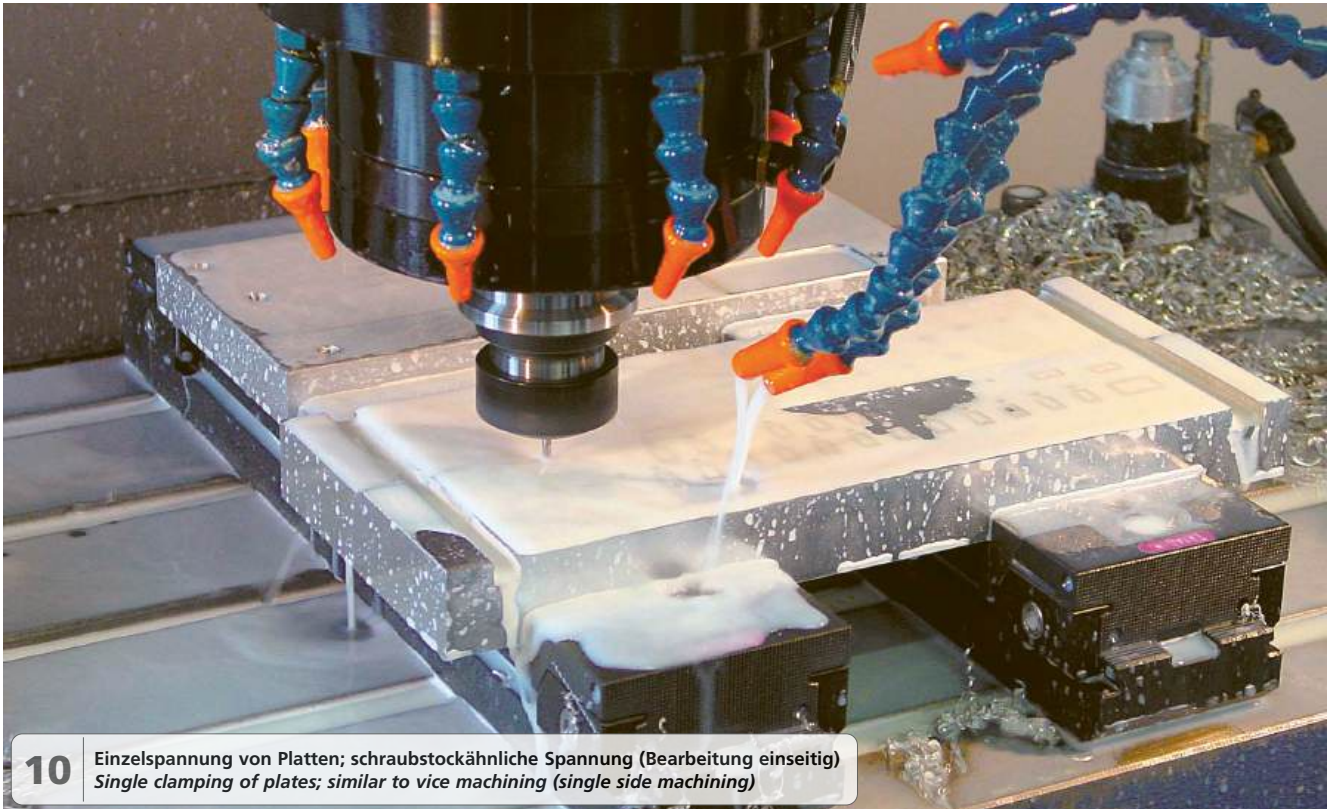

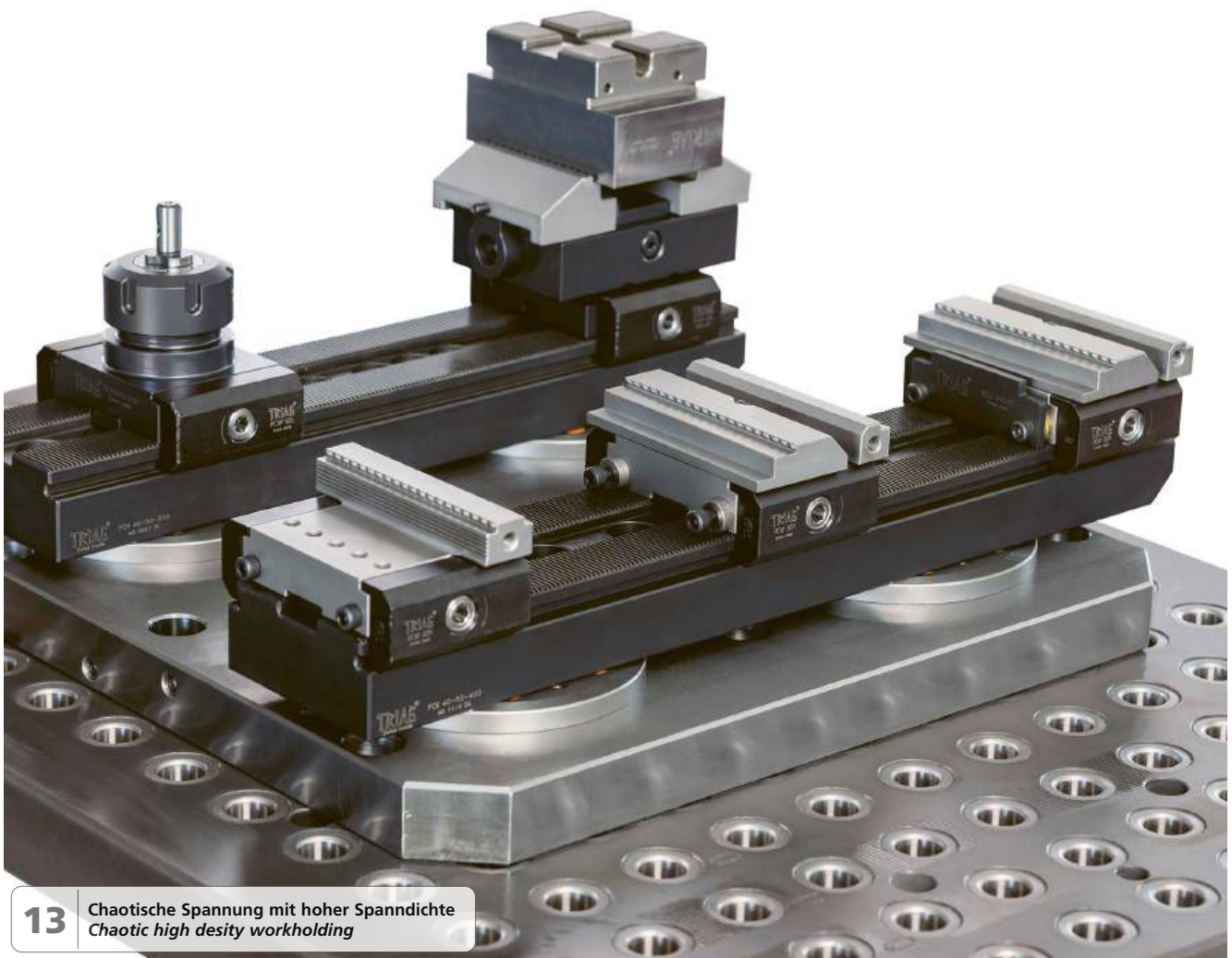

13 Chaotische Spannung mit hoher Spanndichte  
Chaotic high density workholding

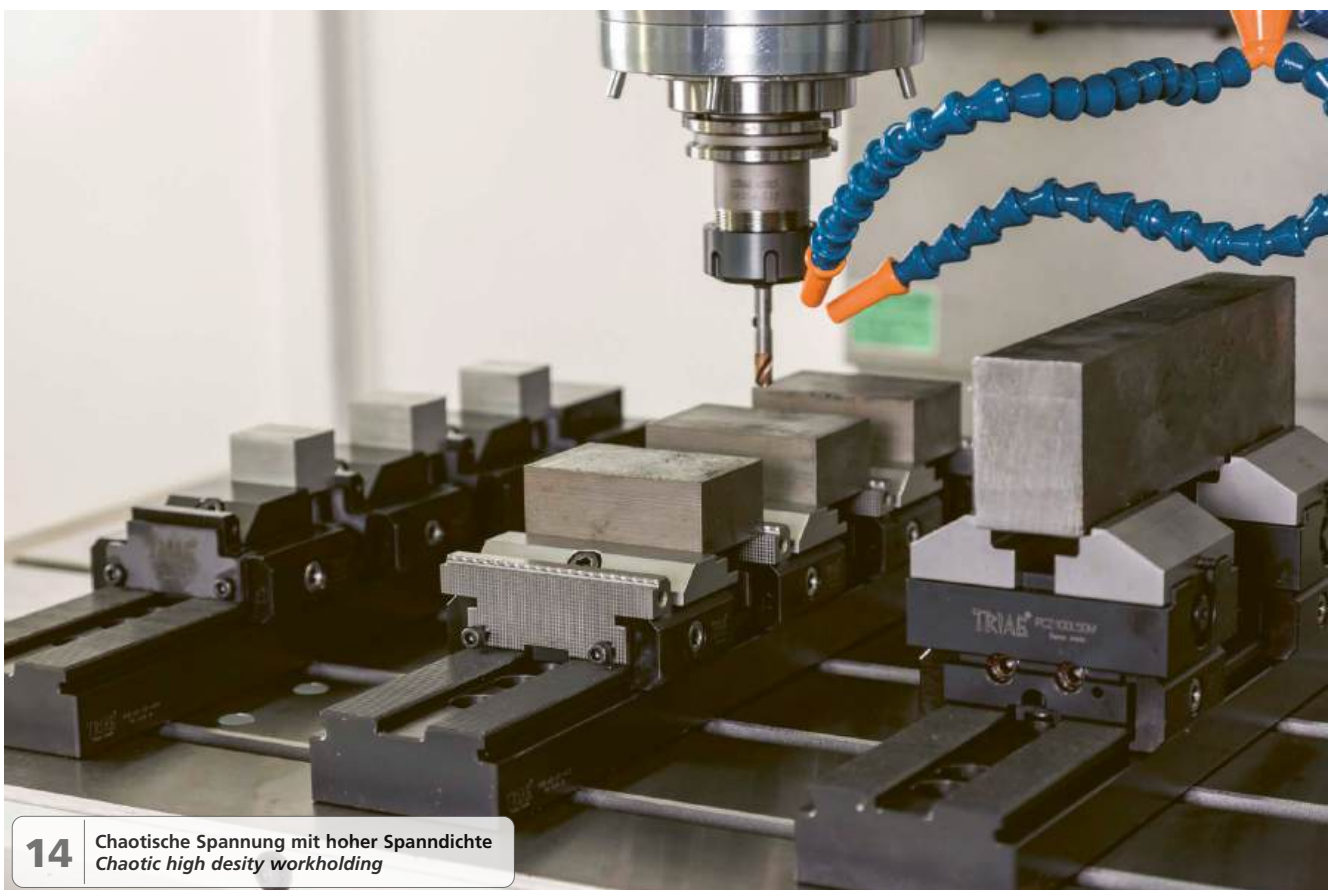

14 Chaotische Spannung mit hoher Spanndichte  
Chaotic high density workholding

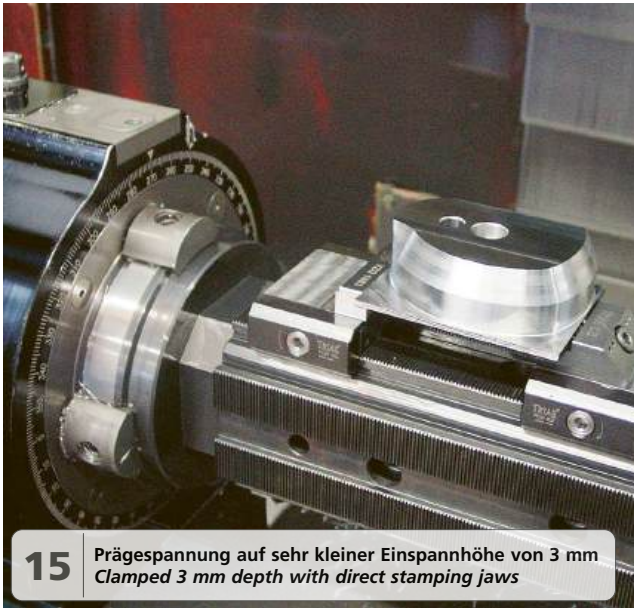

**15** Prägespannung auf sehr kleiner Einspannhöhe von 3 mm  
Clamped 3 mm depth with direct stamping jaws

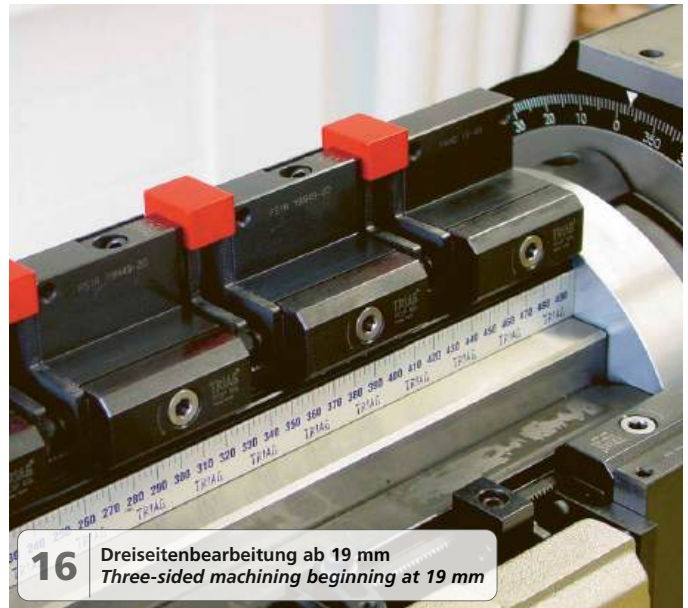

**16** Dreiseitenbearbeitung ab 19 mm  
Three-sided machining beginning at 19 mm



**17** ... im Einsatz auf der 4. Achse  
... in action on the 4th axis



**18** Das Triag Power Clamp im Einsatz als Spannstock (Starterset)  
Triag Power Clamp in action as machine vise (starter set)

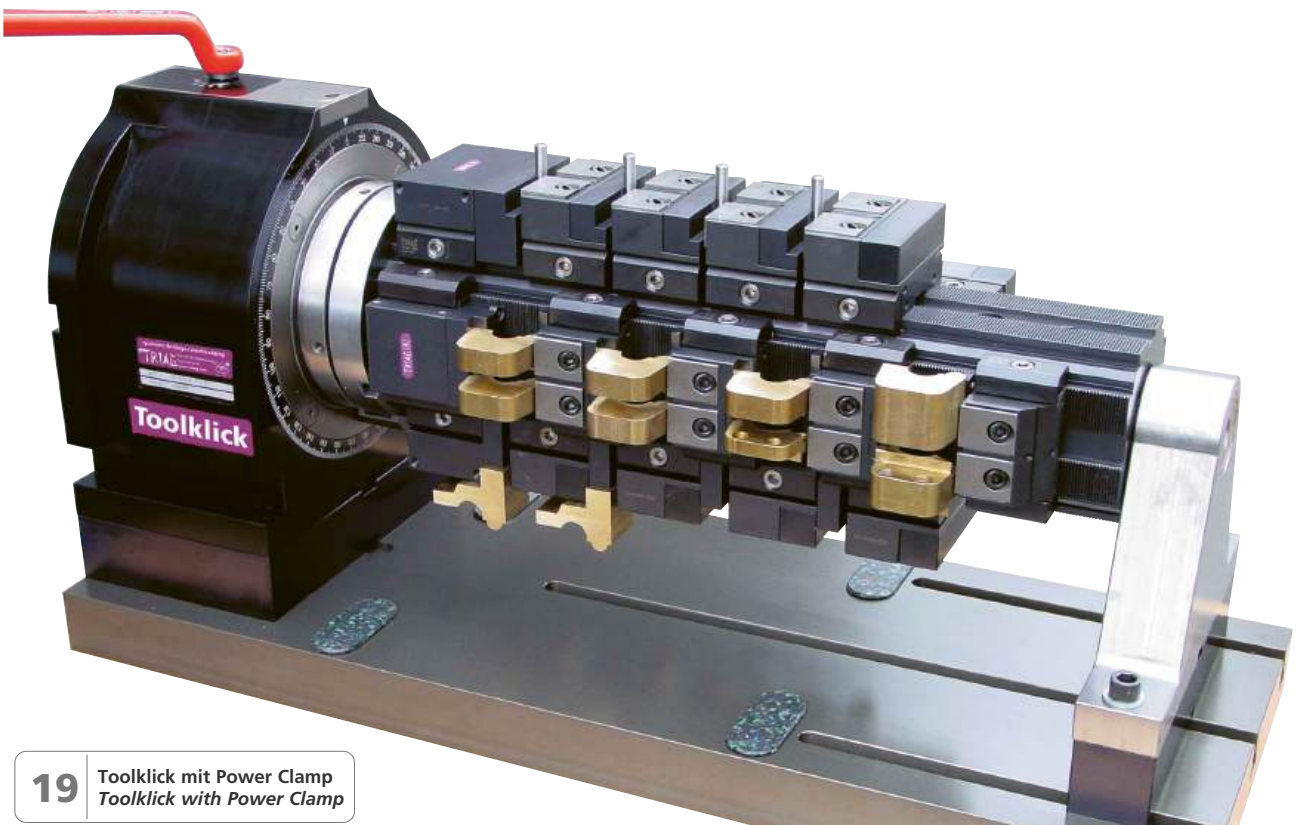

**19** Toolclick mit Power Clamp  
Toolclick with Power Clamp

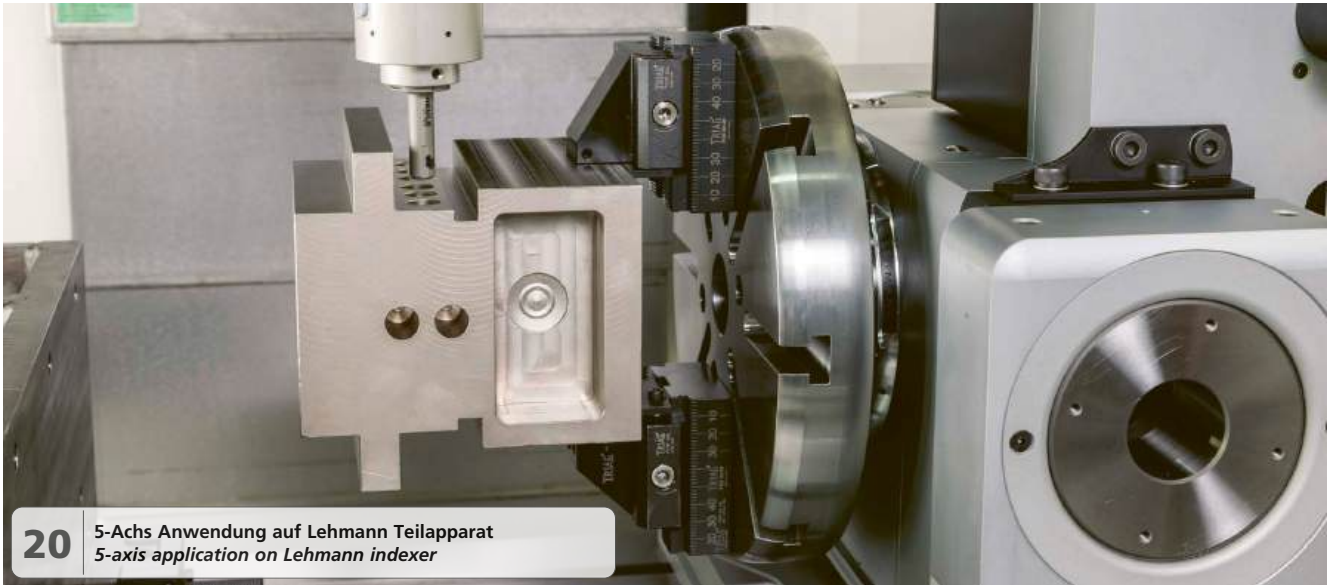

**20** 5-Achs Anwendung auf Lehmann Teilapparat  
5-axis application on Lehmann indexer

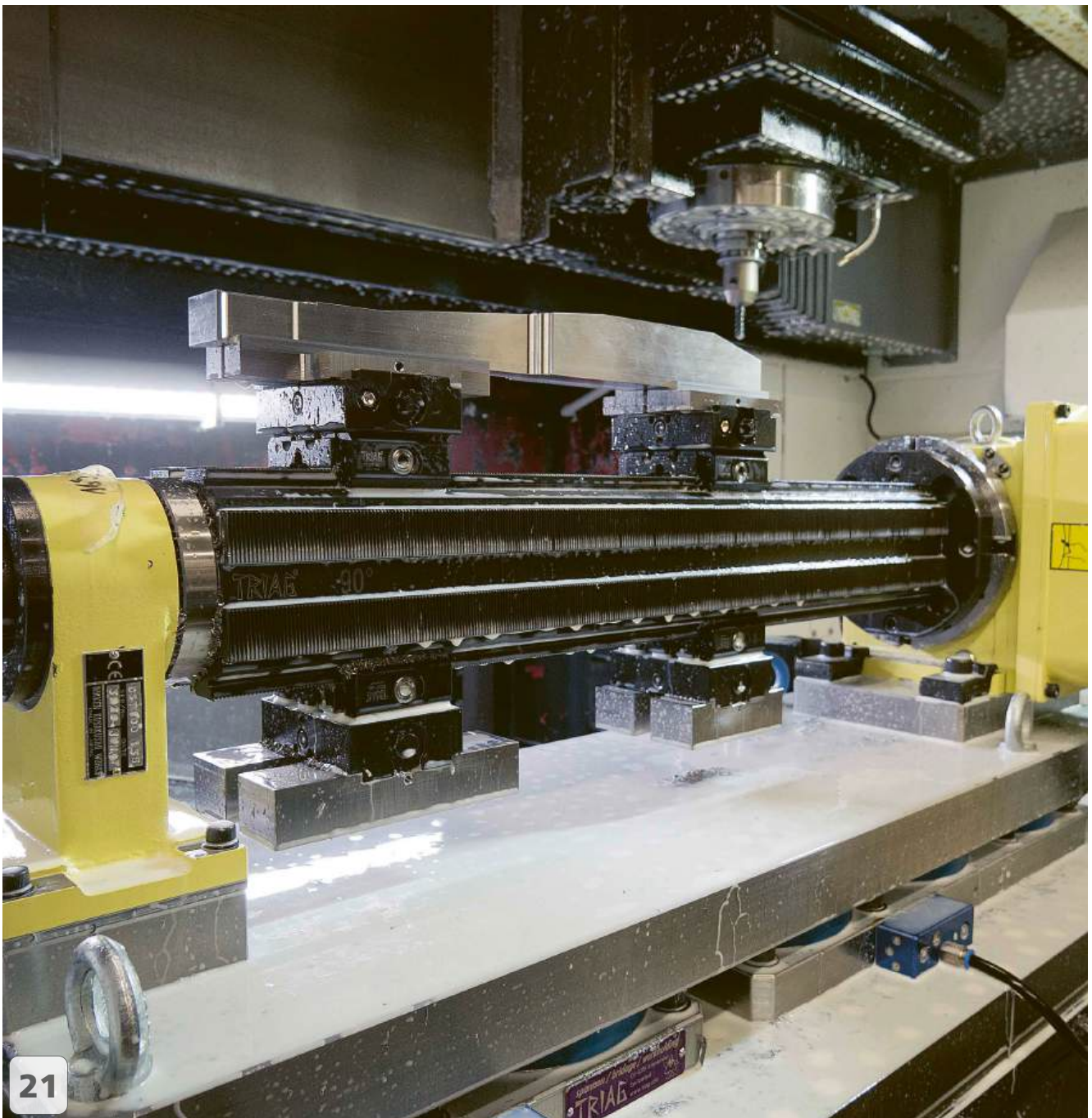

**21**

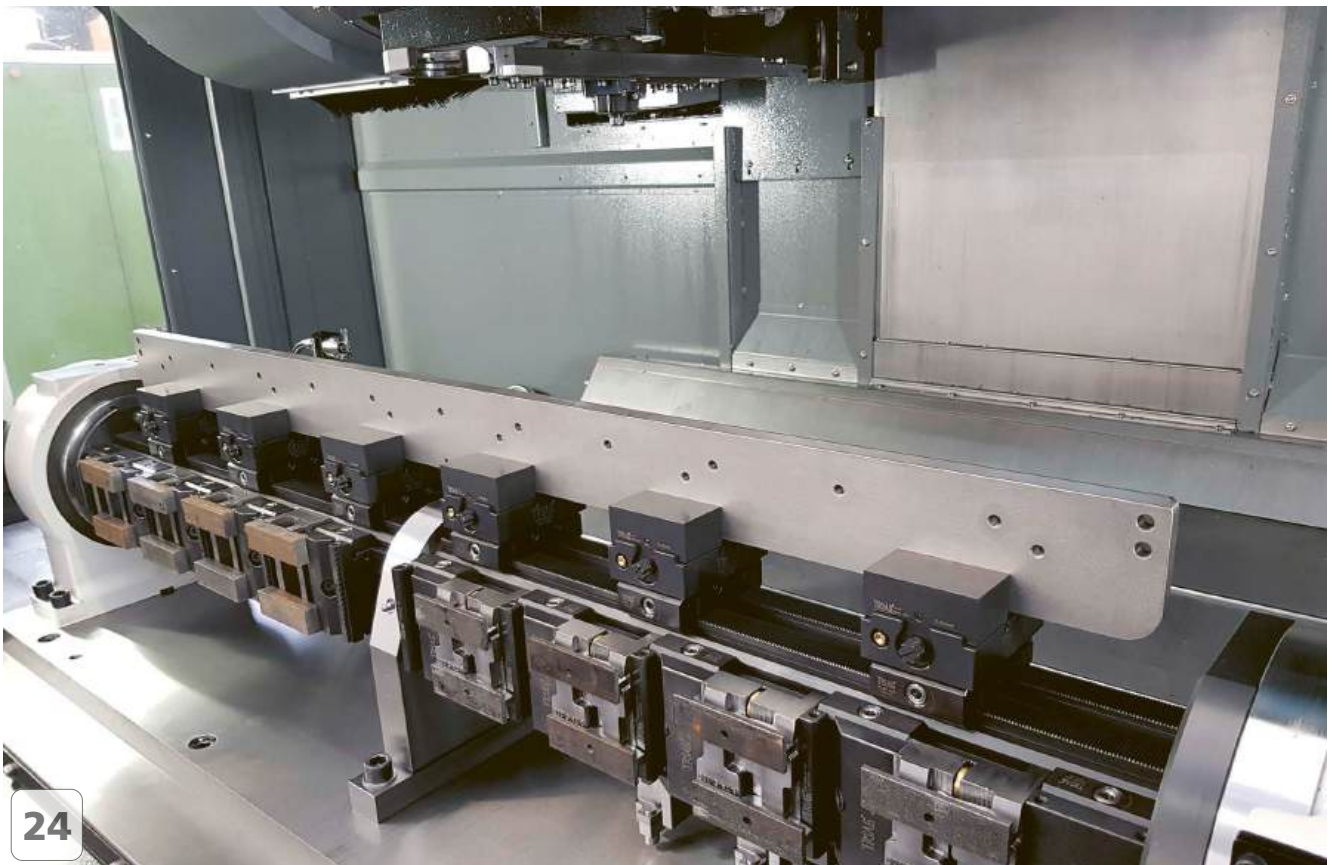
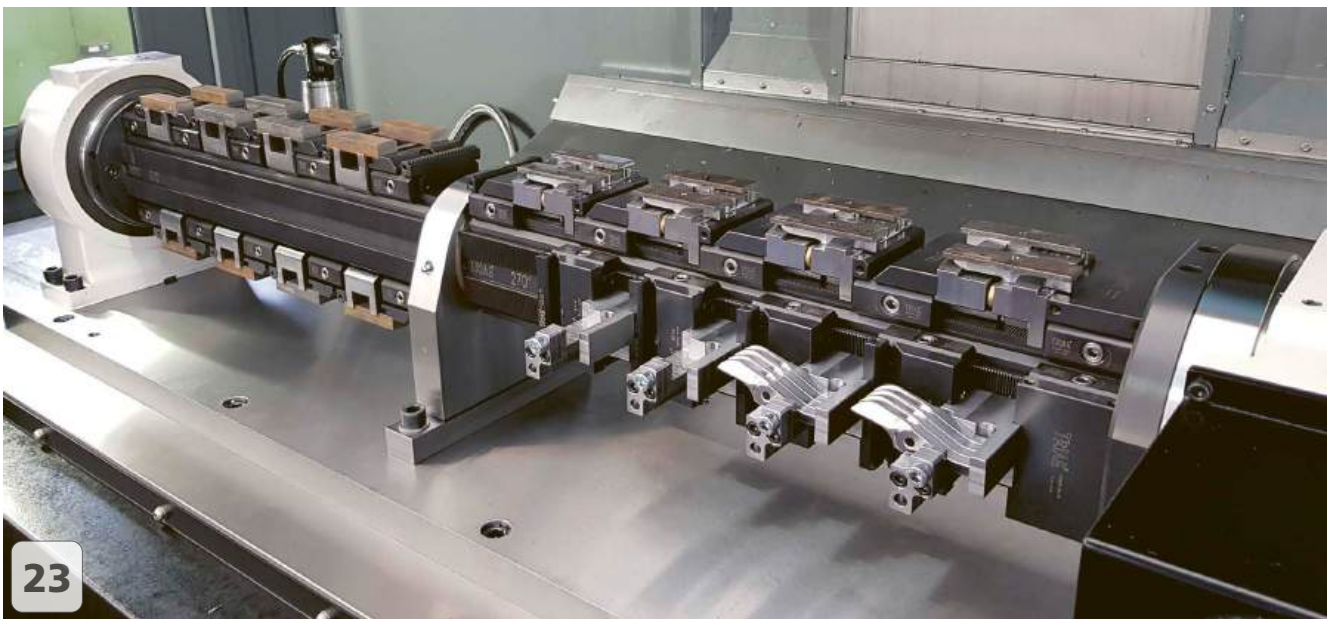
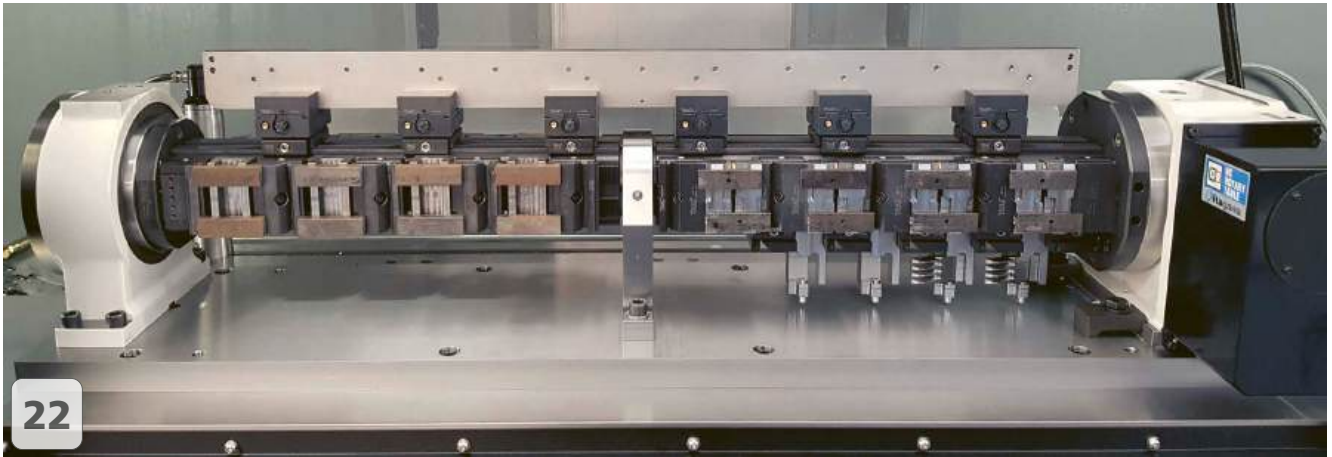

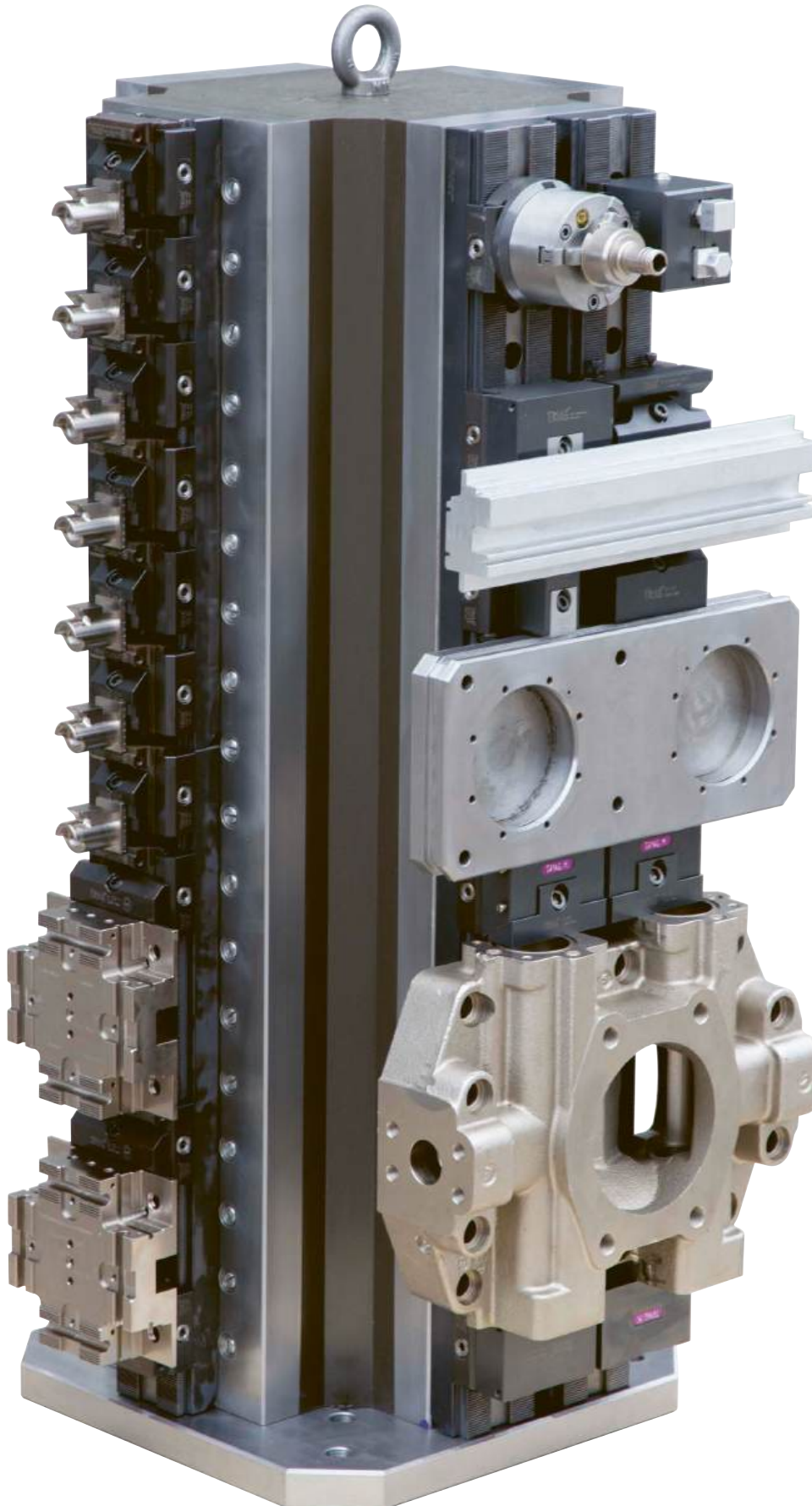

**25** tripoxyMINERAL Kreuzturm mit PowerCLAMP Schienen für chaotische Spannung  
tripoxyMINERAL Cross version with PowerCLAMP baserails for chaotic workholding

**31** tripoxyMINERAL mit unterschiedlichen Werkstücken bestückt  
tripoxyMINERAL tombstones holding a variety of workpieces



**32** Zentrischspanner auf einem Spezialturm  
Centric vices installed on a special tombstone

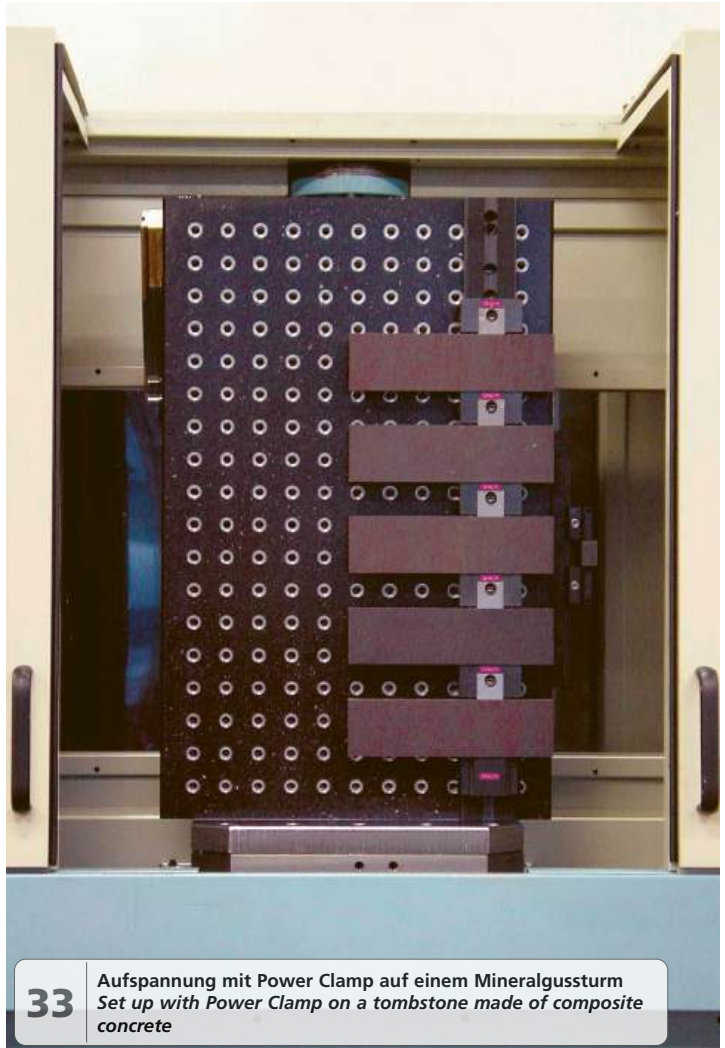

**33** Aufspannung mit Power Clamp auf einem Mineralgussturm  
Set up with Power Clamp on a tombstone made of composite concrete

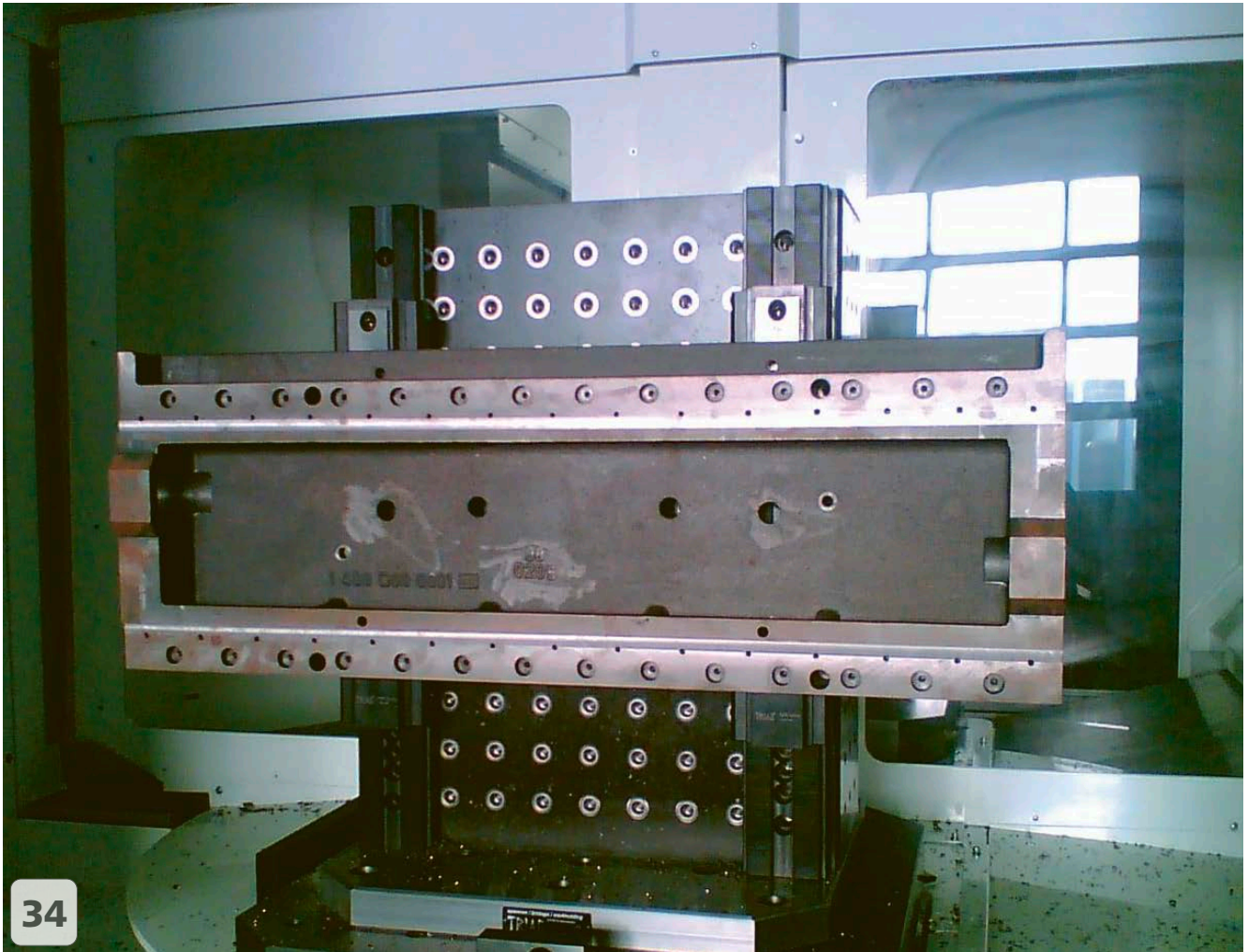

34

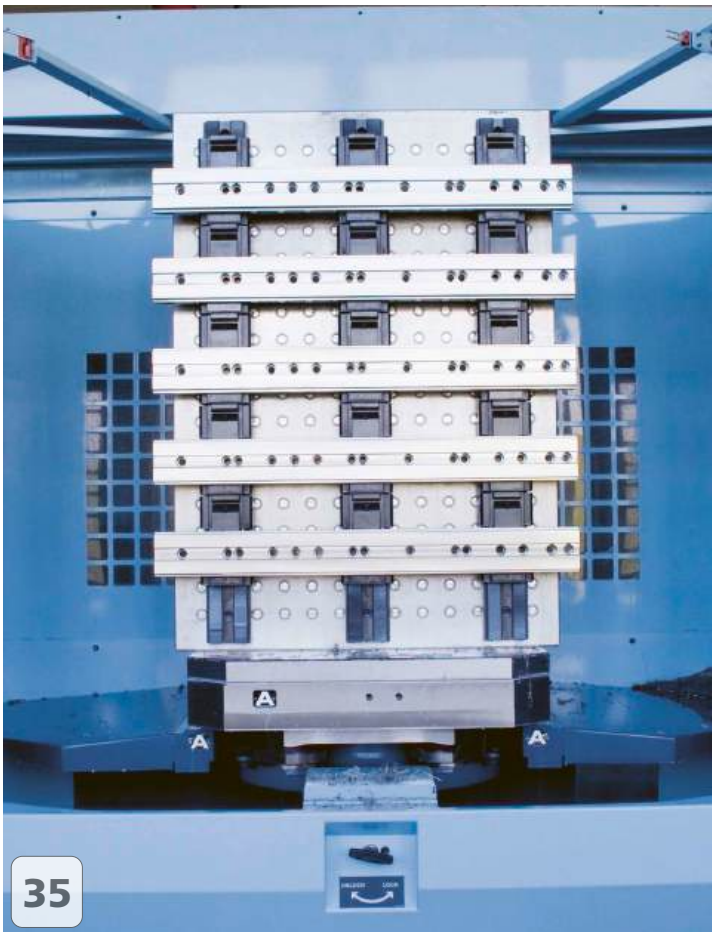

35

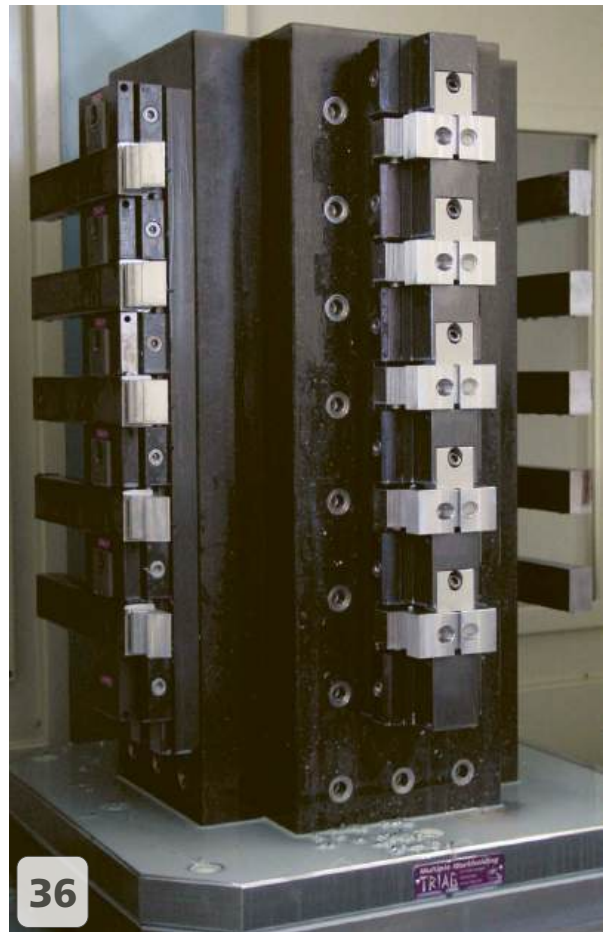

36

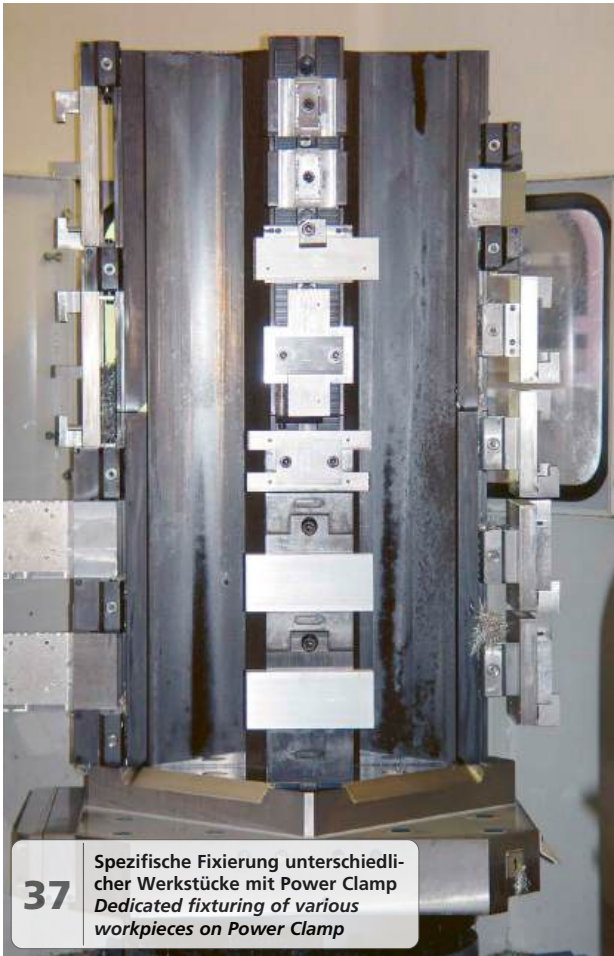

**37** Spezifische Fixierung unterschiedlicher Werkstücke mit Power Clamp  
*Dedicated fixturing of various workpieces on Power Clamp*



**38** Prägespannung auf sehr kleiner Einspannhöhe von 3 mm  
*Clamped 3 mm depth with direct stamping jaws*

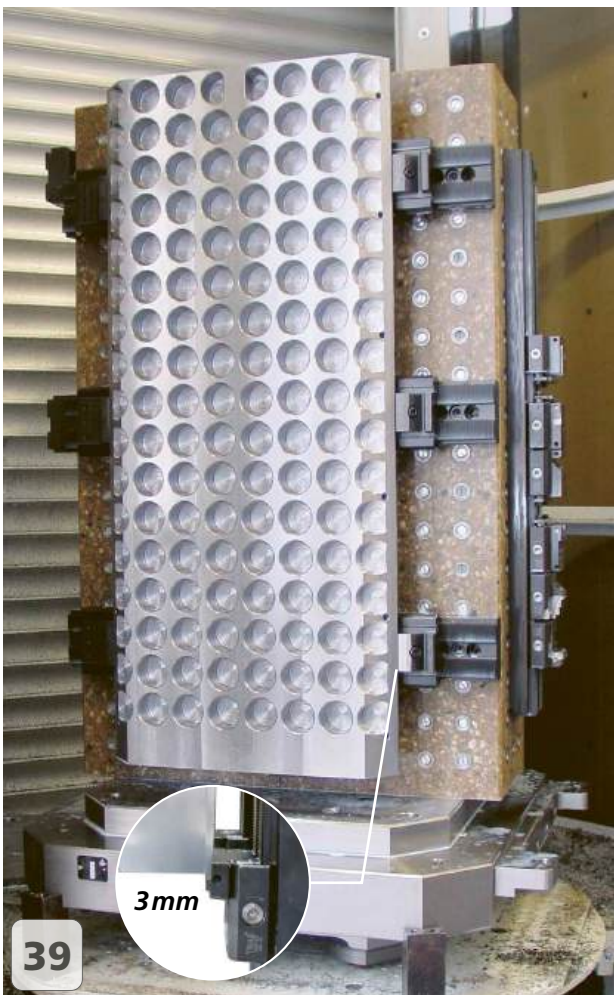

**39**

3mm

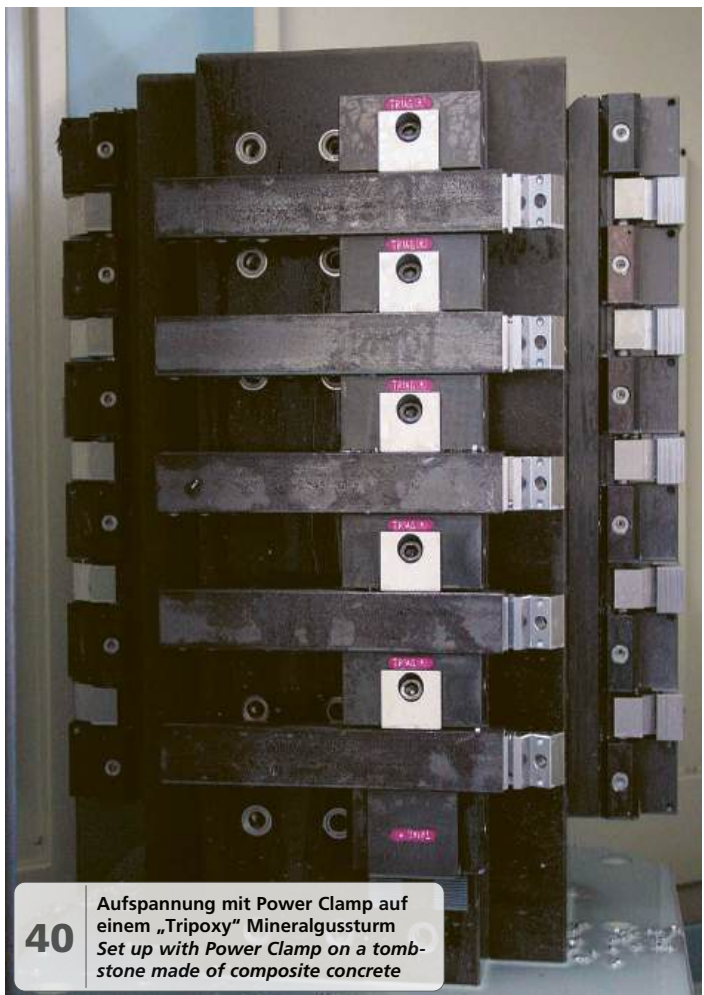

**40** Aufspannung mit Power Clamp auf einem „Tripoxy“ Mineralgussturm  
*Set up with Power Clamp on a tombstone made of composite concrete*

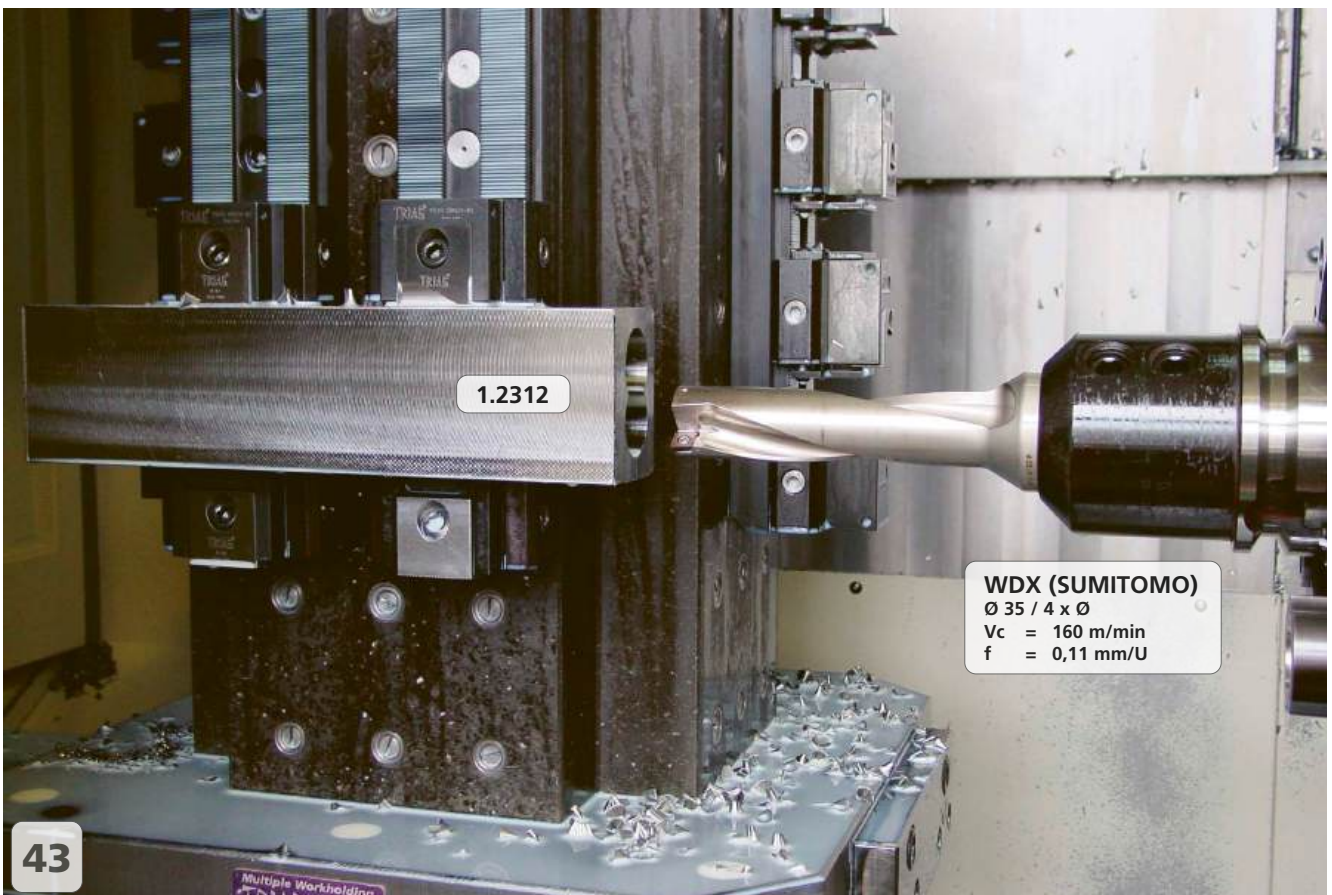
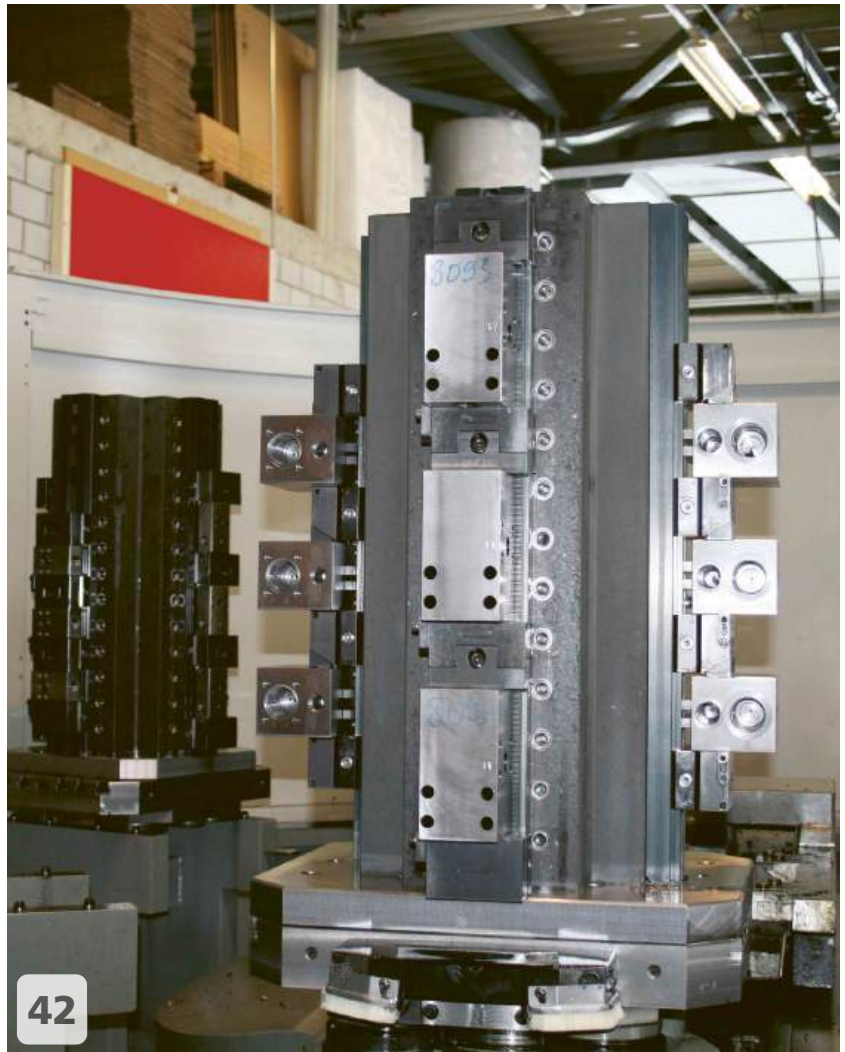
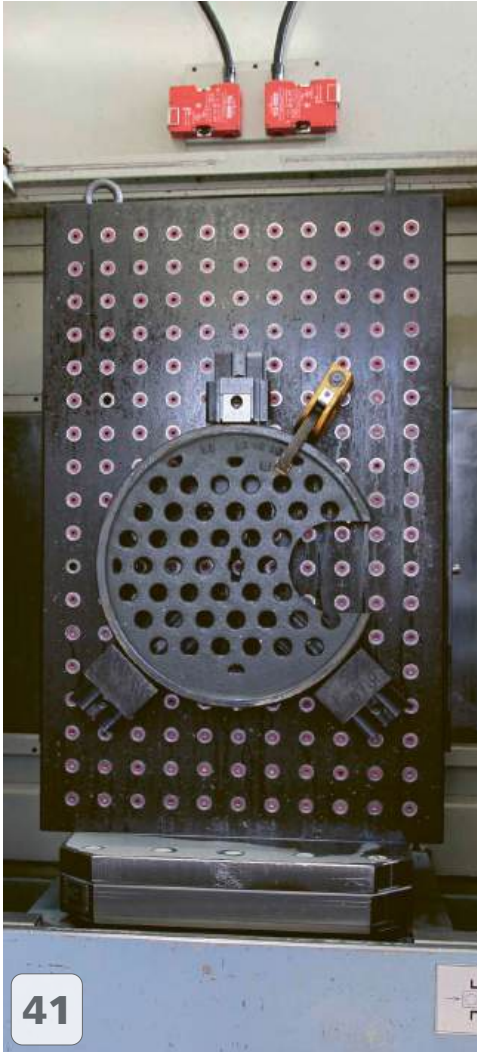

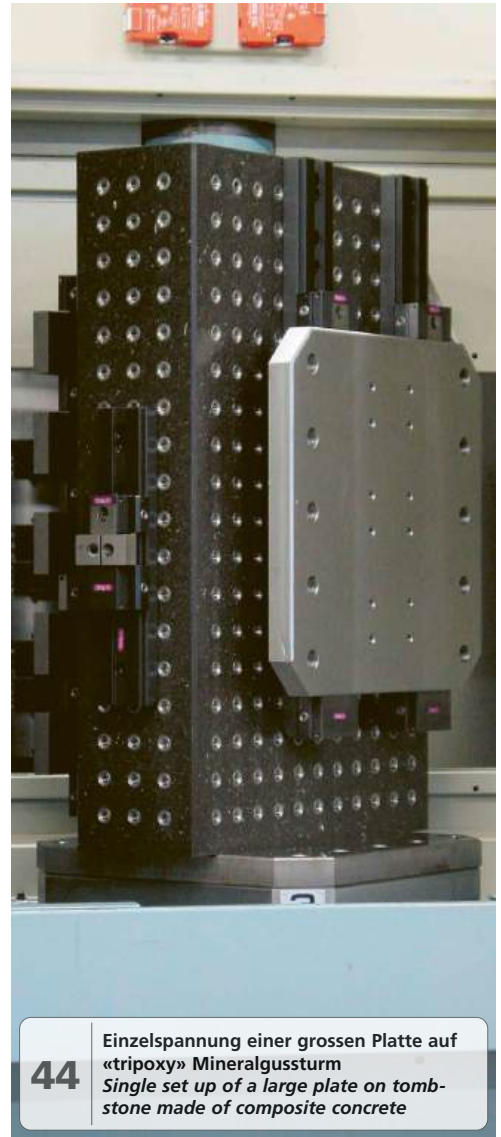

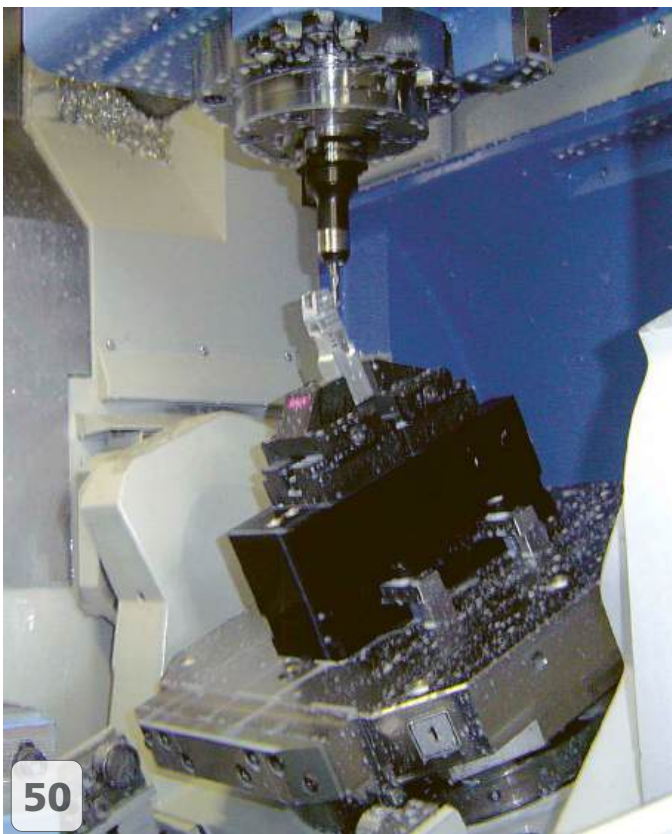
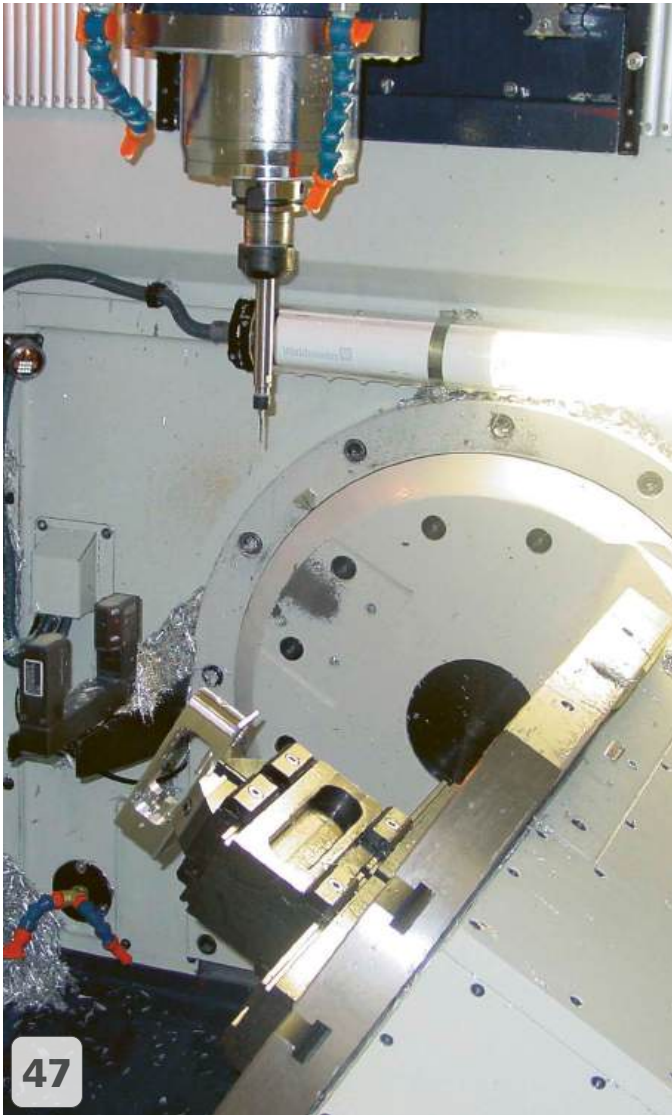

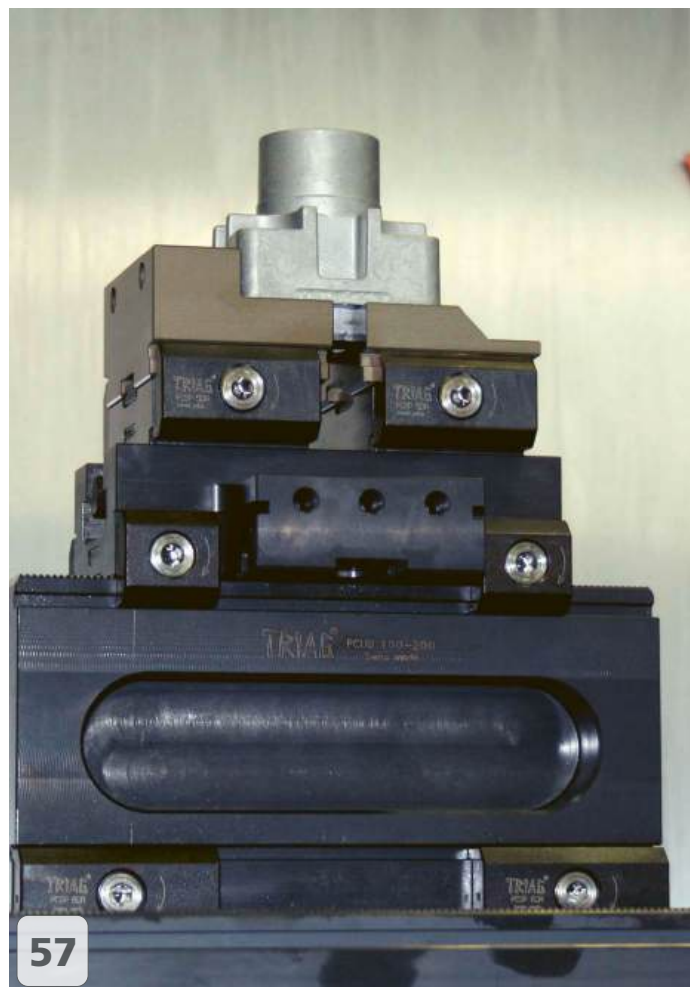
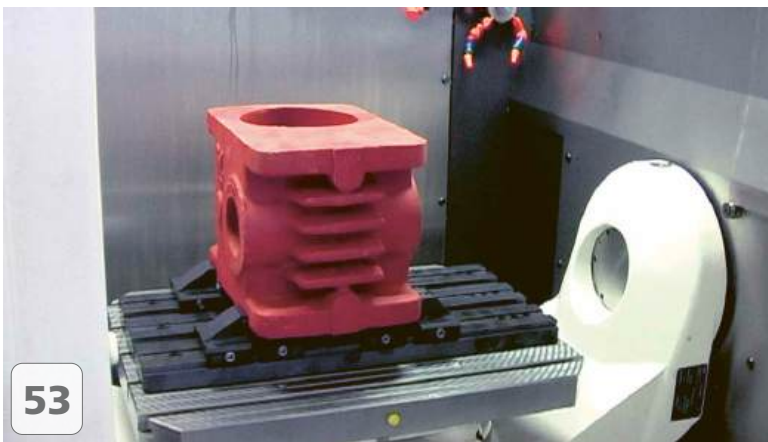



58



59



60



61

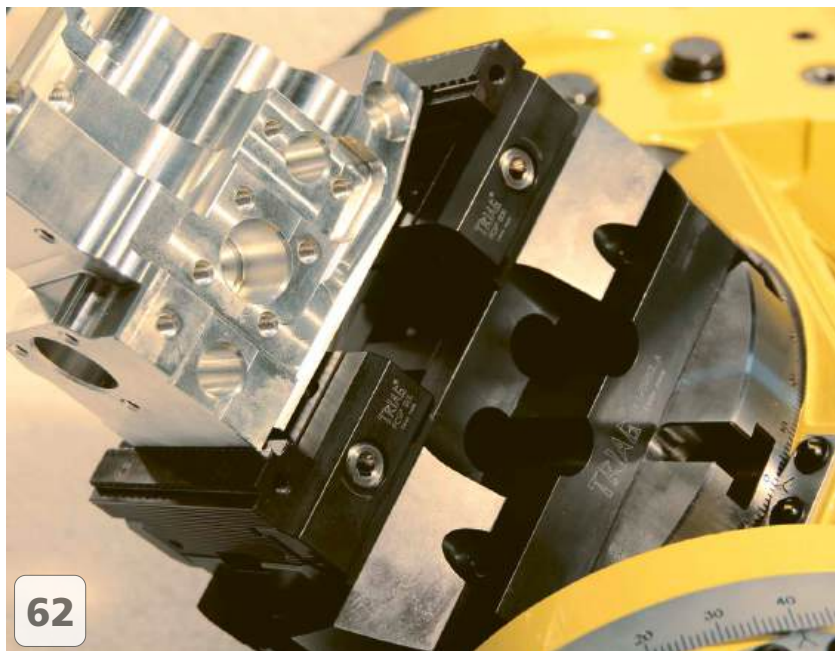

62

### Modulares Mehrfachspannen auf 5-Achsen-Maschinen

Immer öfter werden die 5-Achsen-Maschinen in den Produktionsabläufen eingesetzt, um den Ansprüchen der heutigen effizienten Herstellung gerecht zu werden und weltweit wettbewerbsfähig zu bleiben. Die Werkstückspannung ist sehr anspruchsvoll und fordert die technischen Mitarbeiter ausserordentlich, wie auf den nachfolgenden Bildern dargestellt.

### Modular workholding system for 5-axis machines

Increasingly, the 5-axis machines are used in the production processes to be in accordance with the demands of today's efficient manufacturing and remain globally competitive. The workpiece clamping is very demanding and calls for extremely technical staff, as shown on the following pictures.

### Vorteile der Triag 5-Achsen Spannsysteme:

- Die unteren Basisschienen dienen sowohl als mechanisches Nullpunktspannsystem, aber auch als Spannstock.
- Die Spannkraft wirkt direkt beim Werkstück, trotzdem ist das Werkstück ob klein, lang oder gross mit kurzen Werkzeugen sehr gut zugänglich. (Die Einschränkung ist der Maschinentisch)!
- Bei der Dreiseitenbearbeitung ist auch Mehrfachspannung möglich.
- Es können über 200 verschiedene Spannmodule, sowie Rohmodule, Zentrischspanner, Dreibackenfutter, Spannzangenfutter, Vakuumspannmodule usw. aufgesetzt werden. Die Schnittstelle ist immer dieselbe.
- Sehr schnelles Umrüsten!
- Wenig Reinigungsaufwand, da keine T-Nuten vorhanden sind.
- Besonders gut geeignet für 5-Achsen-Maschinen. Alle Spannvorrichtungen können auch auf Horizontal- und Vertikalmaschinen universell eingesetzt werden.

### Benefits of Triag 5-axis workholding systems:

- The lower base rails serve both as a mechanical zero-point clamping system, but also as a vice.
- The tension acts directly at the workpiece, the workpiece is still, whether small, long or large, very accessible with short tools. The constraint is the machine table!
- 3-side machining is possible as well.
- There may be placed over 200 different clamping modules, as well as raw modules, self-centring modules, three jaw chuck, collet chuck, vacuum clamping modules and so on. The interface is always the same.
- Very fast setup!
- Reduced cleaning required, since no T-slots available.
- Especially suitable for 5-axis machines. All clamping devices can also be used universally on horizontal and vertical machines.



Geeignet sowohl für kleine ...  
Especially suited for small ...

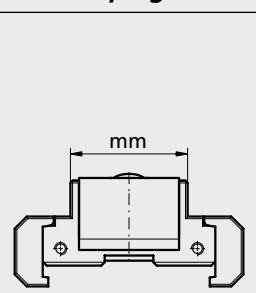
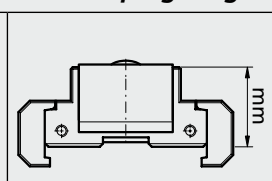

... als auch für grosse Werkstücke!  
... as well as large workpieces!

System System		bei Anschlagmodulen for end module		Modulnutzbreite Module clamping width		Modulnutzhöhe Module clamping height	
A	Apto Clamp	N	nitriergehärtet nitrated	19		34	
P	Power Clamp	D	durchgehärtet through hardened	25			
C	Compact Clamp	<b>bei Spanmodulen for vice modules</b>		26			
M	Micro Clamp	1	Anzahl Spannbacken Number of jaws	34			
V	Vorrichtungsbaumodule Workholding modules for dedicated fixtures	2		43			
		3		48			
		-	keine Spannbacke no clamping jaw	58			
				61			
				68			
				78			

**P S 1 R 48 N 34 -80**

Modultyp Type of module	
A	Anschlagmodul End module
S	Spannmodul Clamping module
T	Trägermodul Supporting module
R	Rohling Blank

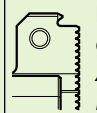
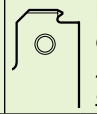
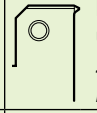
Anschlagfläche der Module Datum face	
F	Anschlagfläche glatt Datum face flat
R	Anschlagfläche geriffelt Datum face double serrated
D	eine Seite glatt, eine Seite geriffelt one face flat, one face double serrated
G	Anschlagfläche gerillt Datum face serrated
X	spezielle Ausführung special execution
5X	5axes Clamp
P	 Fläche unterhalb der Prägung gerillt Area below the stamping serrated
PF	 Fläche unterhalb der Prägung glatt Smooth surface below the stamping
PV	 Präge vorstehend, Fläche unterhalb der Prägung glatt Stamping protruding, surface below the stamping flat
P6	prägen / stamping

Backenhub Stroke of clamping jaw	
N	Niederzug Pull down
L	linear / parallel linear / parallel
-	ohne Spannbacke no clamping jaw

Spannbackentyp Type of clamping jaw	
B01	Spannbacken Clamping jaws
- B313	
-013	Modul ohne Spannbacken Module without clamping jaw
-105	

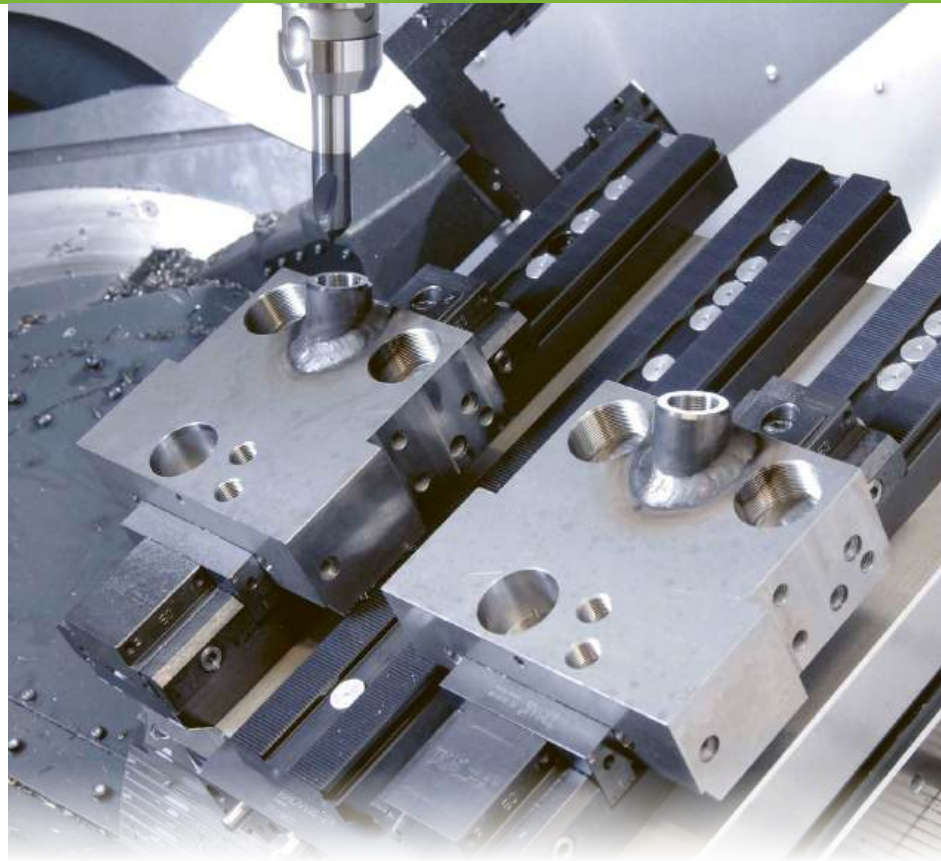

**Die Basisschiene ist die Grundlage des Power Clamp Spannsystems**

Der Einsatz der Basisschiene als Modularspannstock ist jedem Mechaniker ein Begriff. Die Vorteile ihres Einsatzes als mechanisches Nullpunktsystem sind in der Zwischenzeit ebenfalls ins Planungsdenken der mechanischen Fertigung eingeflossen.

Die Power Clamp-Schiene dient als Basis für über 200 verschiedene Spannmodule, Zentrischspanner, Rohlingsmodule und Vakuumplatten.

**The serrated base rail is the basic structure of the Power Clamp workholding system**

Using the base rail as a modular workholding vise is standard practice to any mechanic. The advantages of using it as a zero point system have also widely influenced the planning stages of mechanical production.

The Power Clamp base rail serves as a supporting plate for more than 200 different clamping modules, self centring vises, blank modules and vacuum clamping plates.

Toleranz gilt für alle PCB-Basisschienen / Tolerance applies to all PCB base rails

Toleranzklassen  
Tolerance classes

P6	+0.06
P5	+0.05
P4	+0.04
P3	+0.03
P2	+0.02
P1	+0.01
P0	+0.005
M0	-0.005
M1	-0.01
M2	-0.02
M3	-0.03
M4	-0.04
M5	-0.05
M6	-0.06

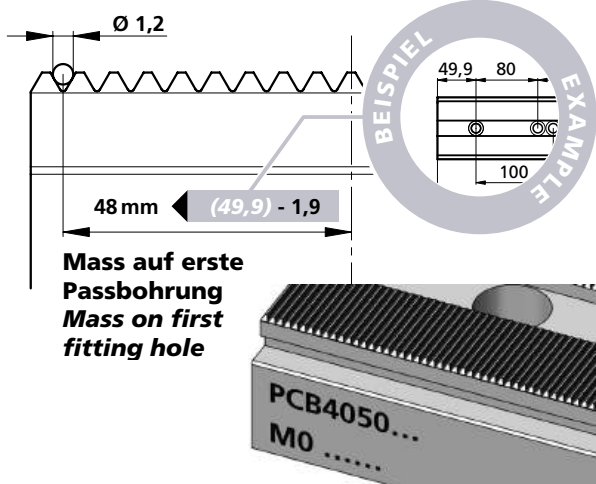

Montagevideo  
Assembly video



PCB6090 kg ~1,7

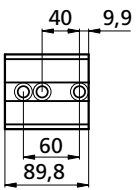

PCB25300 kg ~5,4

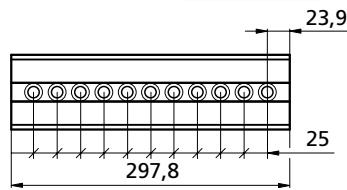

PCB4050500 kg ~9,5

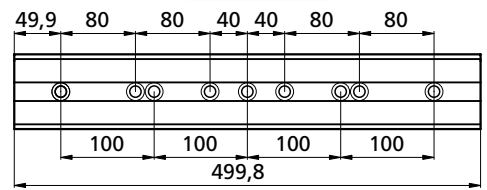

PCB4050125 kg ~2,3

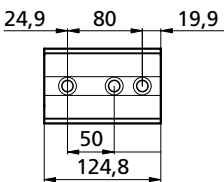

PCB25200 kg ~3,6

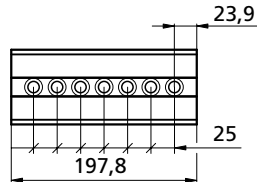

PCB4050550 kg ~10,3

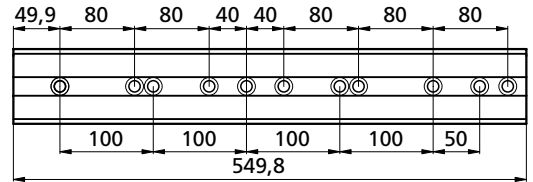

PCB4050220W2 kg ~4,1

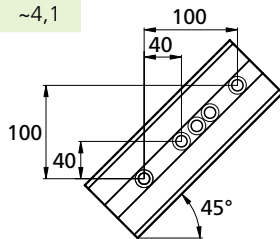
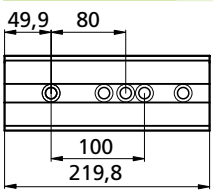

PCB4050600 kg ~11,3

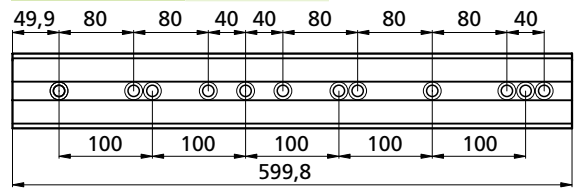

PCB2550250 kg ~4,5

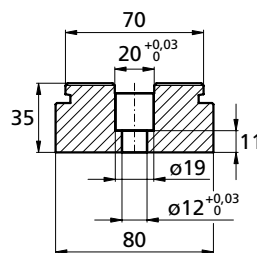
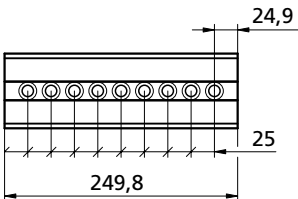

PCB4050650 kg ~12,2

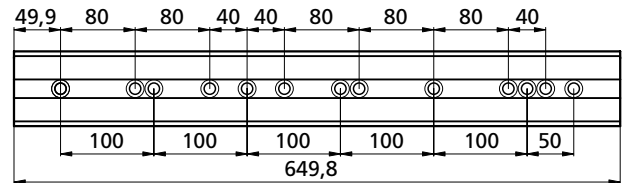

PCB50320 kg ~6,0

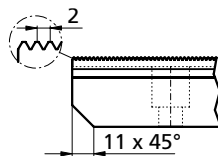
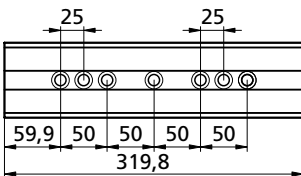

PCB4050700 kg ~13,2

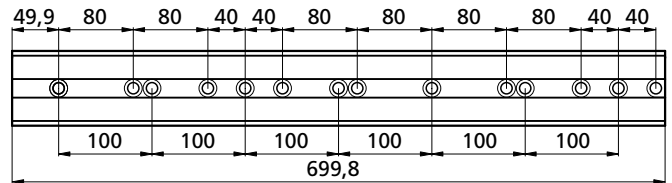

PCB4050350 kg ~6,5

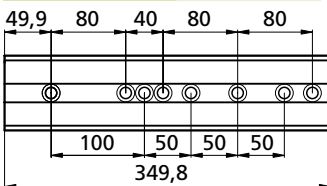

PCB4050750 kg ~14,1

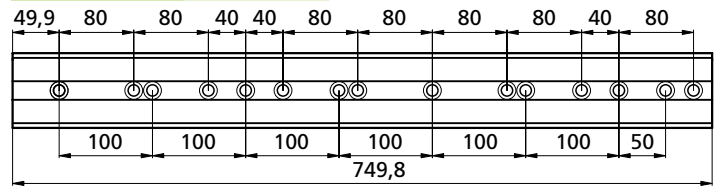

PCB4050400 kg ~7,5

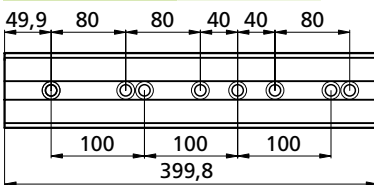

PCB4050800 kg ~15,0

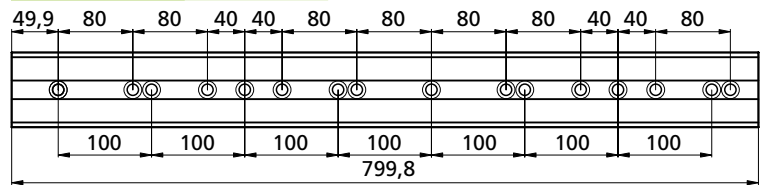

PCB4050450 kg ~8,4

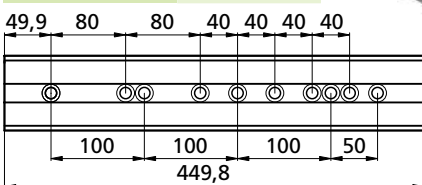

PCB4050400

Basisschienen in Zoll  
Base rails in inch



Bestellbeispiel / Ordering example: PCB4050125

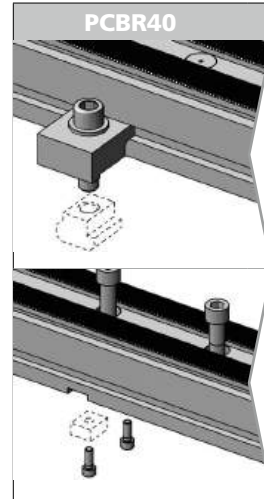
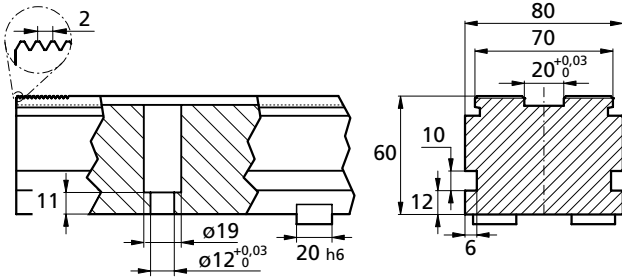

**1. Befestigung 1. Fastening**  
Mit den seitlichen Pratzten, kann die Basisschiene frei auf Ihrem Maschinentisch montiert werden.  
*With the lateral clamps, the base-rail can be mounted freely on your machine table.*

**2. Befestigung 2. Fastening**  
Diese Nutensteine sind zum Ausrichten der Basisschiene auf Ihrem Maschinentisch.  
*These t-slot nuts are for aligning the base-rail on your machine table.*

<b>PCB50320H60</b>	
1	1x TF190449
2	2x M6X12ISO4762
3	2x SM1136-20
kg	~10,3

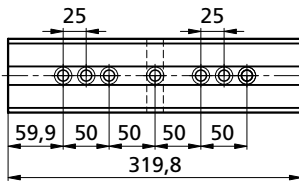

<b>PCB100350H60</b>	
1	1x TH170888
2	2x M6X12ISO4762
3	2x SM1136-20
kg	~11,7

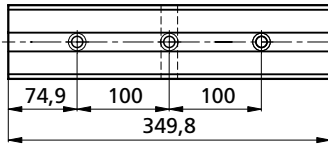

<b>PCB100400H60</b>	
1	1x TB140546
2	2x M6X12ISO4762
3	2x SM1136-20
kg	~13,4

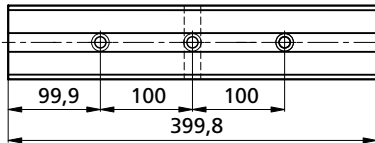

<b>PCB100500H60</b>	
1	1x TB140553
2	2x M6X12ISO4762
3	2x SM1136-20
kg	~16,7

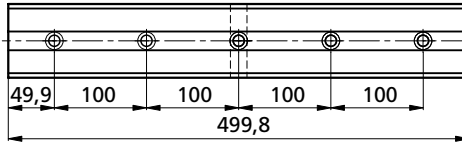

<b>PCB100600H60</b>	
1	1x TB140556
2	2x M6X12ISO4762
3	2x SM1136-20
kg	~20,1

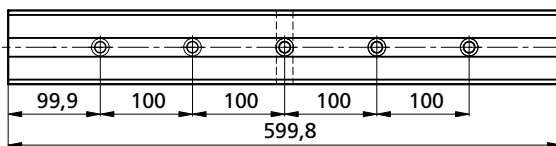

<b>PCB100650H60</b>	
1	1x TB140559
2	2x M6X12ISO4762
3	2x SM1136-20
kg	~21,8

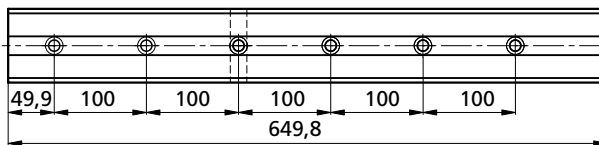

<b>PCB100690H60</b>	
1	1x ZL100122
2	2x M6X12ISO4762
3	2x SM1136-20
kg	~22,6

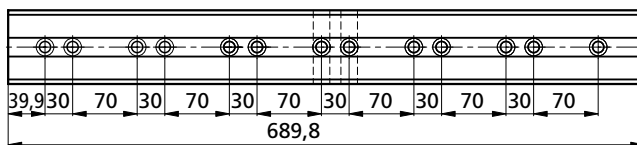

<b>PCB100850H60</b>	
1	1x TB140562
2	2x M6X12ISO4762
3	2x SM1136-20
kg	~27,9

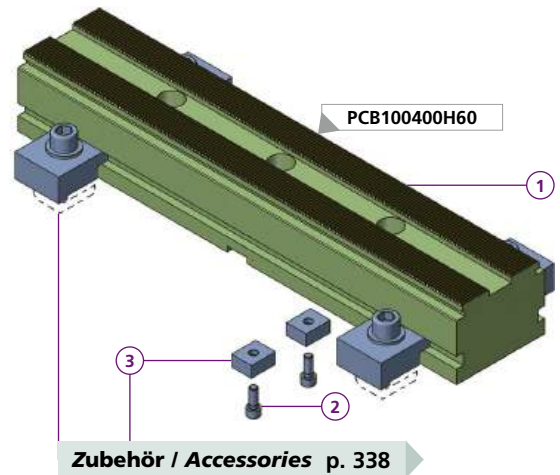
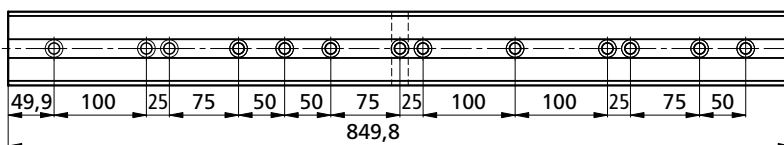

Zubehör / Accessories p. 338

<b>PCBR40</b>	
4	1x M12X45ISO4762
5	1x TN100251
6	1x TK200035
kg	~0,25

**T-Nutensteine T-slot nuts**  
T-Nutensteine je nach Maschinentisch, muss separat bestellt werden.  
*T-slot nuts depending on the machine table, must be ordered separately.*

Bestellbeispiel / Ordering example: 1x PCB100400H60 & 2x M6X12ISO4762 & 2x SM1136-20

PCB4050125H80 kg ~5,5

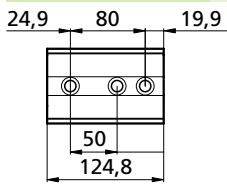

PCB50320H80 kg ~14,5

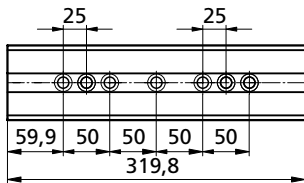

PCB50350H80 kg ~15,5

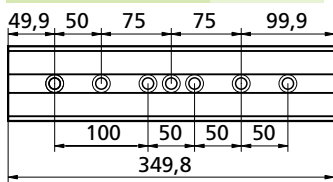

PCB50400H80 kg ~18

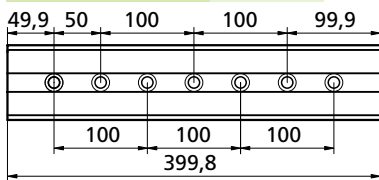

PCB50450H80 kg ~20

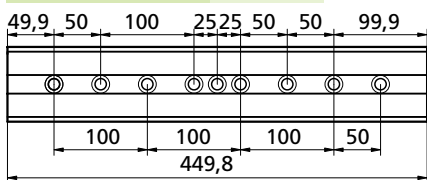

PCB50500H80 kg ~22,5

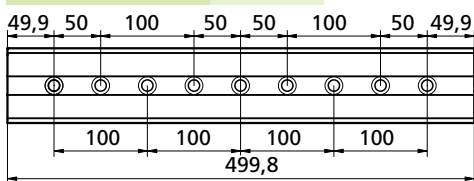

PCB50550H80 kg ~24,5

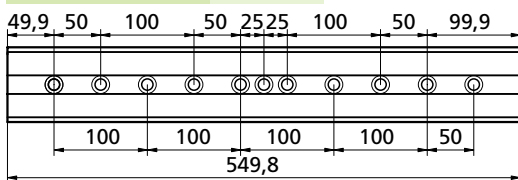

PCB50600H80 kg ~27

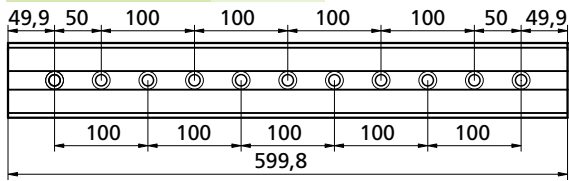

PCB50650H80 kg ~29

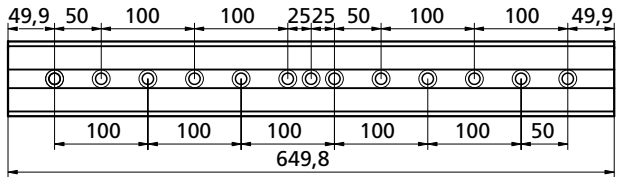

PCB50700H80 kg ~31,5

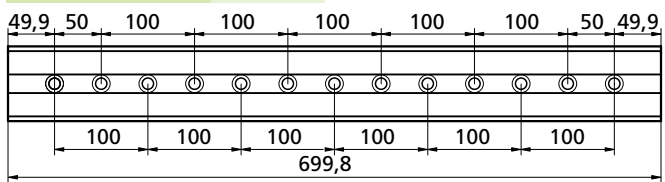

PCB50750H80 kg ~33,5

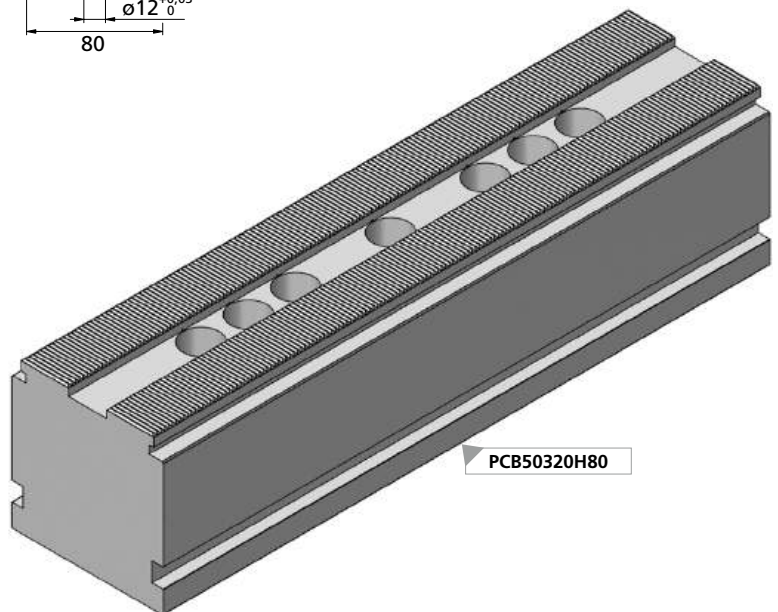
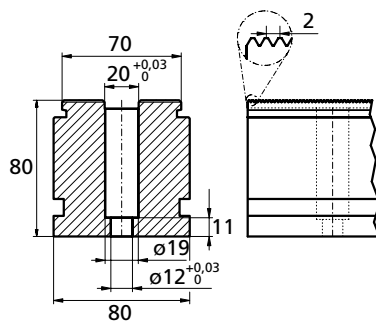
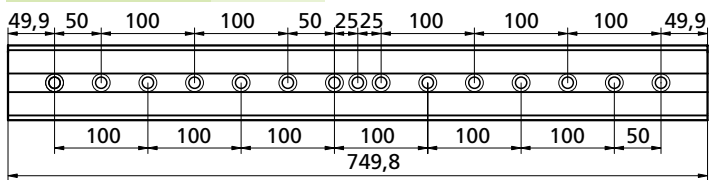

PCB50320H80

PCMB50600H175 kg ~40

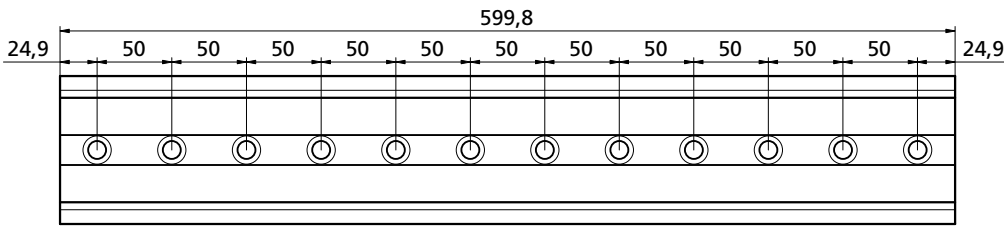

PCMB50500H175 kg ~34

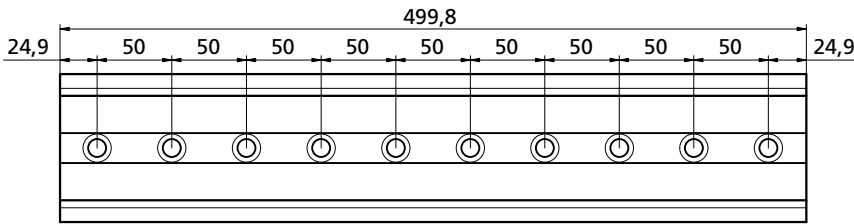

PCMB50400H175 kg ~27

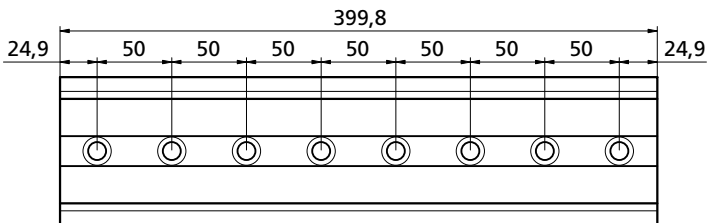

PCMB50300H175 kg ~21

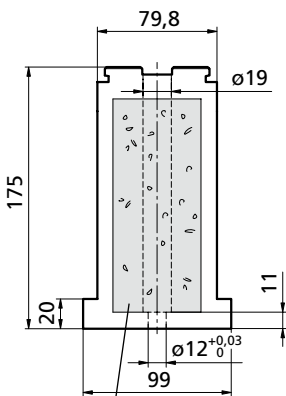
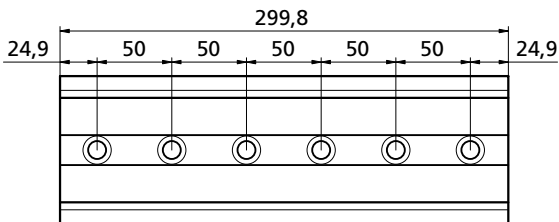

PCMB50400H175

**Epoxy Mineral**  
 Für gute Vibrationsdämpfung  
 For brilliant dampening effect

# Kupplungsstück (Basisschienen zum koppeln) Coupling element (Base rails for coupling)

powerCLAMP

## Kupplungsstücke für PCB Basisschiene auf Mineralgus-Türmen

Mit diesen Kupplungsstücken ist es möglich, die PCB Basisschienen zu verlängern. Aufgrund des durchgängigen Kraftschlusses wird eine übermäßige Belastung des Mineralgussturmes vermieden. Erforderlich ist eine Modifikation der Enden der Basisschienen gemäss der untenstehenden Zeichnung durch den Anwender. Selbstverständlich können neue Schienen bereits mit dieser Modifikation ausgeliefert werden.

So können die zwei Kupplungsstücke montiert werden, die nach dem Platzieren der Schienen eingesetzt und festgezogen werden. Eine zusätzliche Schraube (B) nimmt allfällige, senkrecht zur Befestigungsfläche auftretende Kräfte auf.

## Coupling element for PCB base rails mounted on epoxy mineral tombstones

With this coupling element, it is possible to extend the PCB base rail by a second rail. Due to the frictional connection, the behaviour of the associated items is approximate to the behaviour of a continuous rail. A modification according to the drawing below (made by the customer) is required at the end of the base rails. New base rails can be supplied with this modification.

So the two coupling elements can be placed between the base rails. An additional screw (B) is taken the force flatwise to the seating.

Detailzeichnung zum Bearbeiten aller Basisschienen H35, um die Aussparung für das Kupplungsstück bei vorhandenen Schienen nachträglich herzustellen.

Detail drawing for machining all base rails H35 to retrofit the recess for the coupling piece on existing rails.

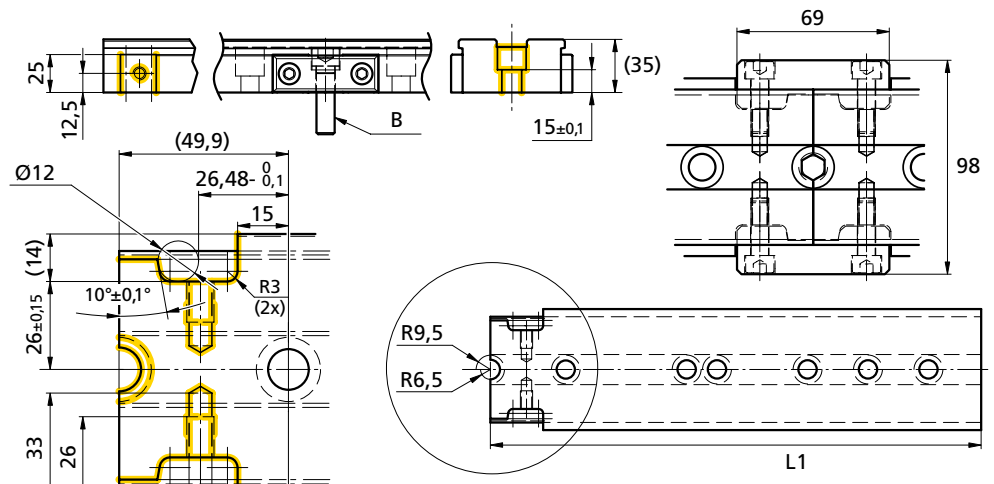

Montageanleitung siehe Video  
Assembly instructions see video

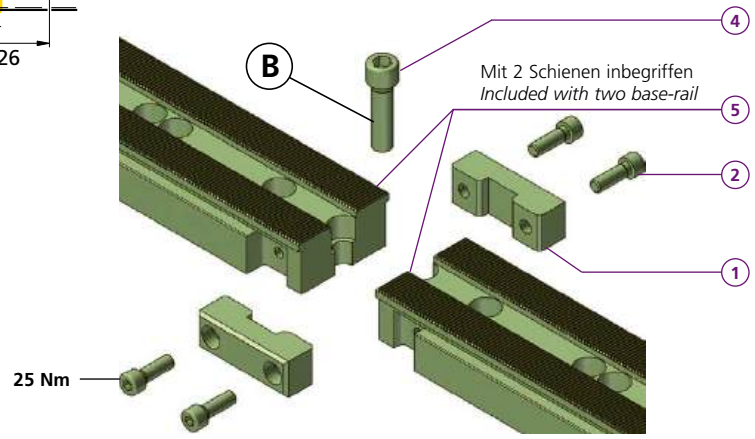

PCBP69SET		PCB4050250KP	PCB4050400KP	PCB4050450KP	PCB4050500KP	PCB4050650KP	PCB4050700KP
1	2x TW090078	5	5	5	5	5	5
2	4x M8X25ISO4762	L1 = 250	L1 = 400	L1 = 450	L1 = 500	L1 = 650	L1 = 700
4	1x M12X45ISO4762	kg ~5,1	kg ~7,9	kg ~8,9	kg ~9,9	kg ~12,8	kg ~13,8
kg	~0,4						

Bestellbeispiel / Ordering example: PCB4050250KP

PCB850SET	PCB900SET	PCB950SET	PCB1000SET
1	1	1	1
1x PCB4050400KP	1x PCB4050650KP	1x PCB4050700KP	2x PCB4050500KP
2	2	2	3
1x PCB4050450KP	1x PCB4050250KP	1x PCB4050250KP	1x PCBP69SET
3	3	3	4
1x PCBP69SET	1x PCBP69SET	1x PCBP69SET	4x TWPAS1240
4	4	4	5
4x TWPAS1240	4x TWPAS1240	4x TWPAS1240	6x M12X40ISO4762
5	5	5	6
5x M12X40ISO4762	6x M12X40ISO4762	6x M12X40ISO4762	10x PCPF16L6
6	6	6	7
9x PCPF16L6	10x PCPF16L6	10x PCPF16L6	8x PCPF16L18
7	7	7	kg
9x PCPF16L18	8x PCPF16L18	9x PCPF16L18	~20,2
kg	~18,2	~19,1	
~17,1			

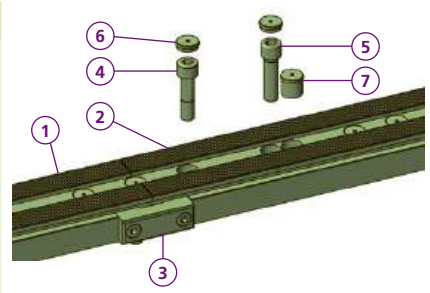

Bestellbeispiel / Ordering example: PCB850SET

# Querschiene 90° Crossbar 90°

PCB250Q90-H35

powerCLAMP

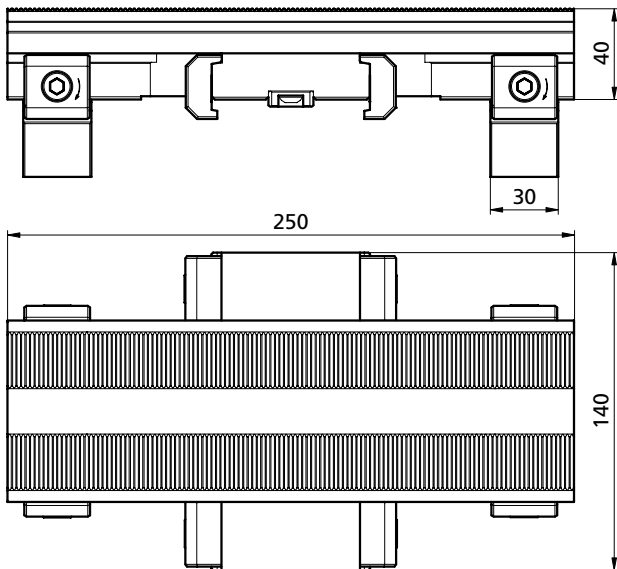
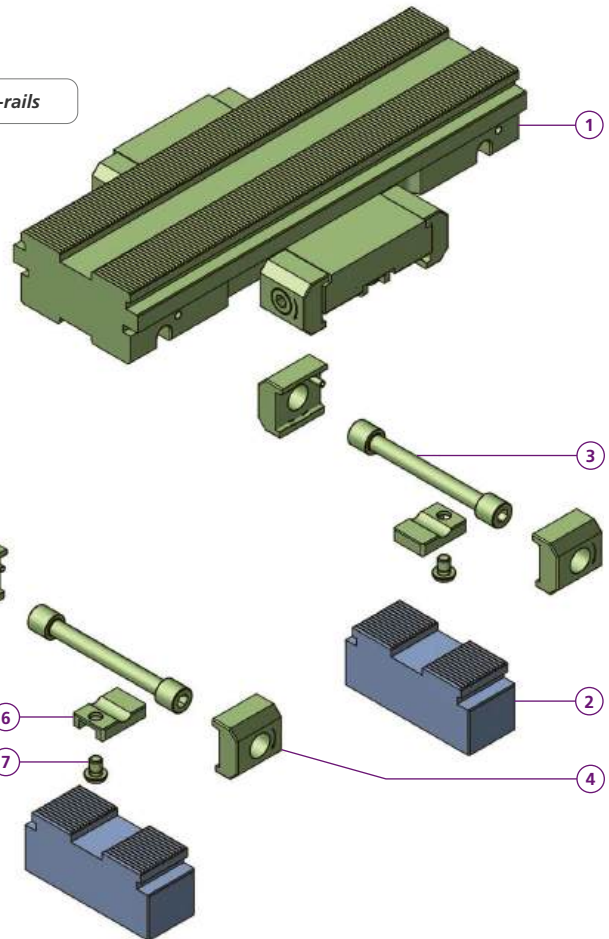
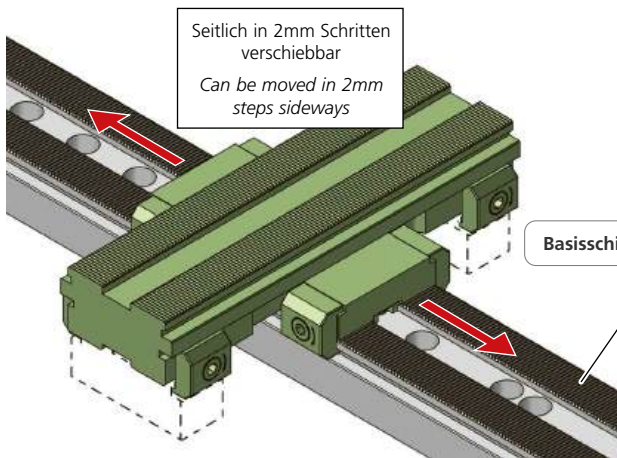
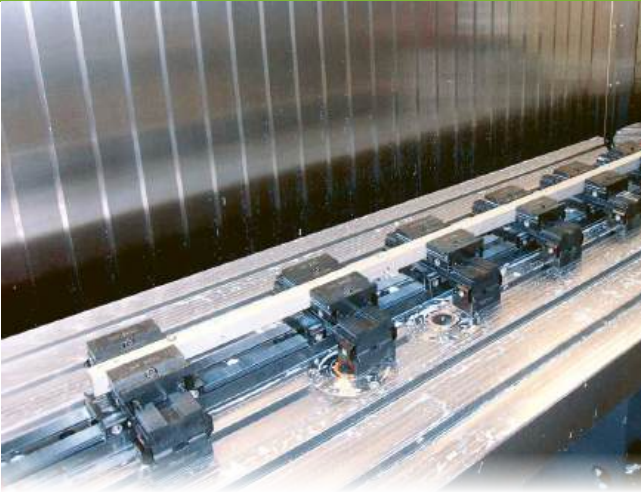

PCB250Q90H35	
①	1x TH151032
②	2x —
③	4x PCS14
④	4x PCSP30L
⑤	4x PCSP30R
⑥	4x PCGU2030
⑦	1x M6X8ISO7380
kg	~8,18

### Schienenhöhe / Rail height

AS35	kg	AS60	kg	AS80	kg
(H = 35)	~0,6	(H = 60)	~1,1	(H = 80)	~1,5

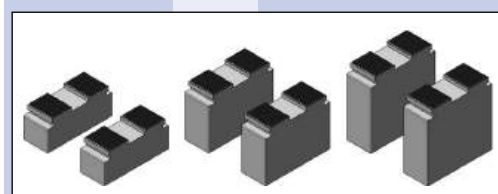

### Seitliche Stützen

Bei Gebrauch der Querschiene 90°, werden je nach Höhe der Basisschiene auf dessen sie aufgesetzt sind, zwei seitliche Stützen AS35 / AS60 / AS80 unterlegt.

### Side support

When using the cross rail 90°, a side support AS35 / AS60 / AS80 is underlaid, depending on the height of the base rail on which it is placed.

Bestellbeispiel / Ordering example: PCB250Q90H35

Separat bestellen / Order separately

# Erhöhung für 5-Achsenmaschinen Riser for 5-axis machines

PCUB60-130  
PCUB100-200  
PCUB100-300

**powerCLAMP**

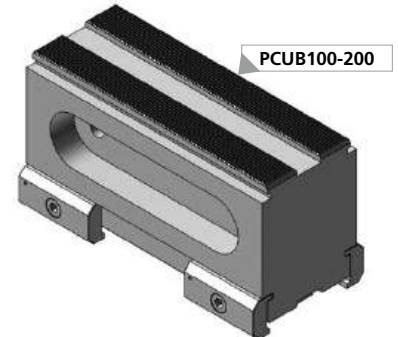
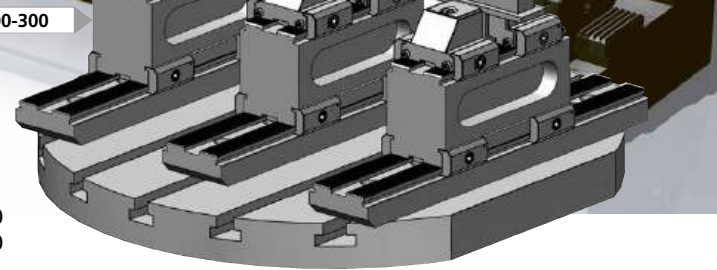
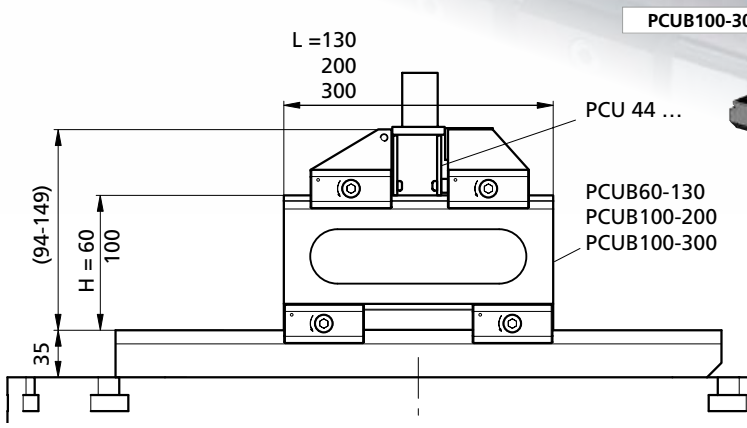
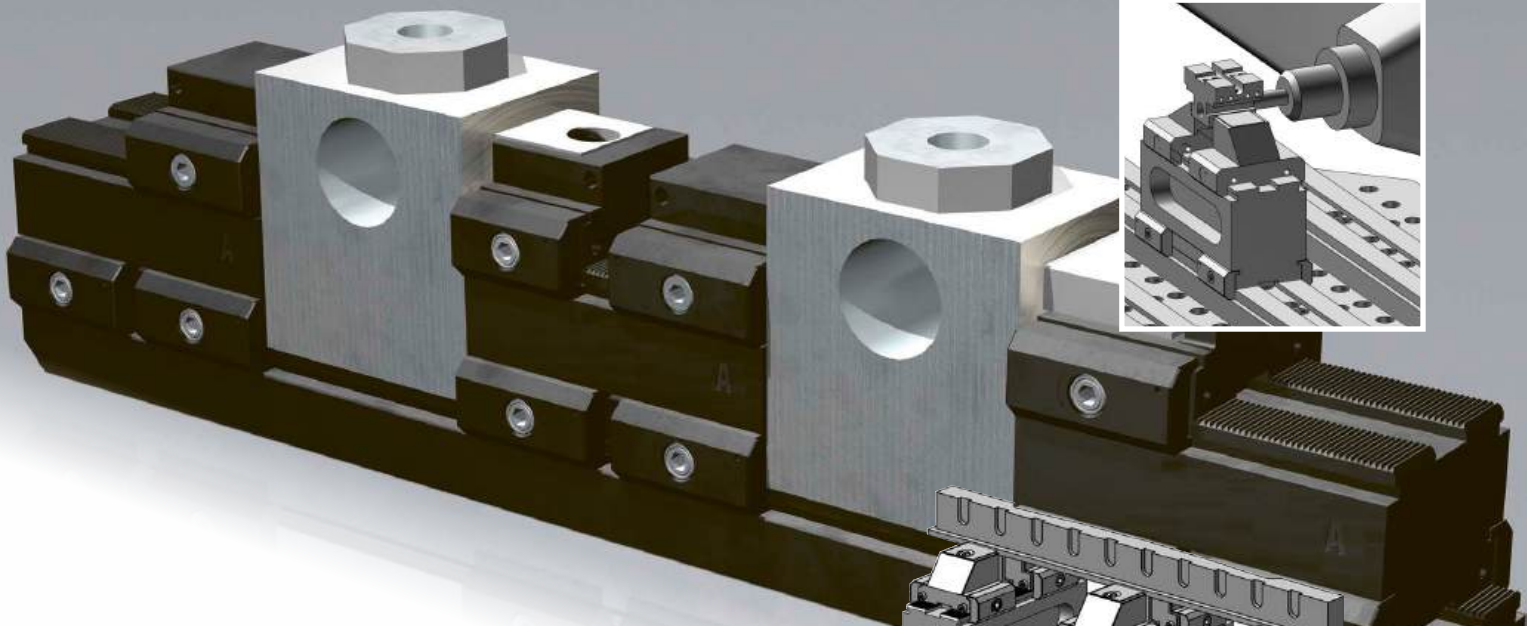

- | PCUB60-130  |                |
|-------------|----------------|
| 1           | 1x TK120596    |
| 3           | 2x PCSP60R     |
| 4           | 2x PCSP60L     |
| 5           | 2x PCS14       |
| 6           | 2x PCGU2049    |
| 7           | 2x M6X8ISO7380 |
| L           | = 130          |
| H           | = 60           |
| kg          | ~5,8           |
| PCUB100-200 |                |
| 1           | 1x TK130108    |
| L           | = 200          |
| H           | = 100          |
| kg          | ~10,5          |
| PCUB100-300 |                |
| 1           | 1x TK130109    |
| 3           | 3x PCSP60R     |
| 4           | 3x PCSP60L     |
| 5           | 3x PCS14       |
| 6           | 3x PCGU2049    |
| 7           | 3x M6X8ISO7380 |
| L           | = 300          |
| H           | = 100          |
| kg          | ~16            |

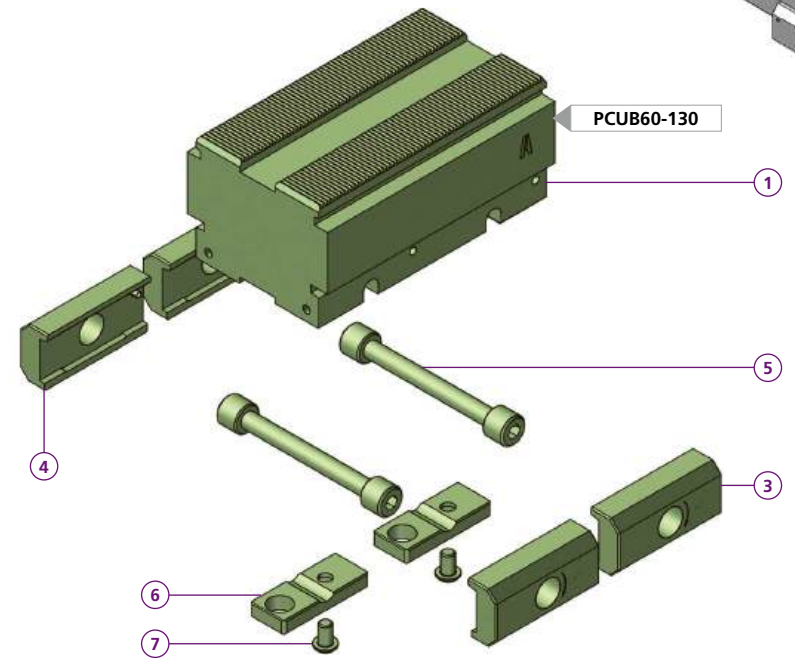

Bestellbeispiel / Ordering example: **PCUB100-200**

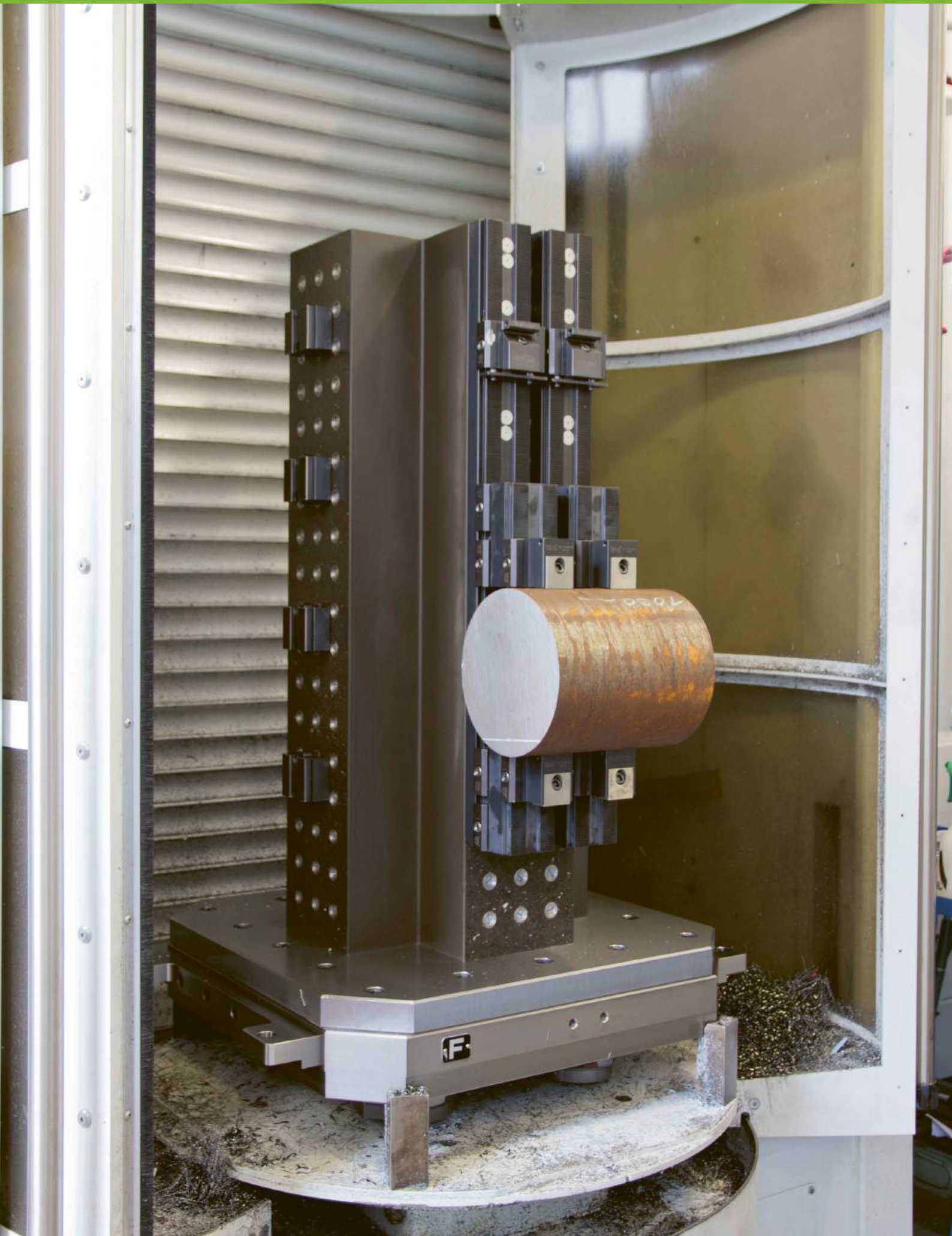

# PCUB115-200-R25

# PCUB115-300-R25

powerCLAMP

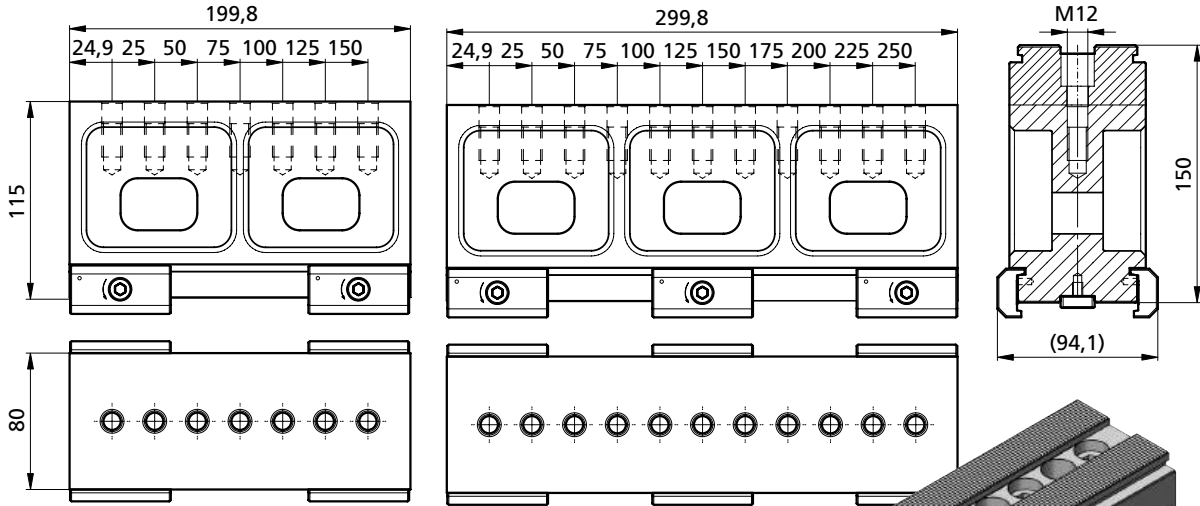

**PCB25200** kg ~3,6

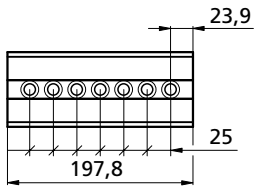

**PCB25300** kg ~5,4

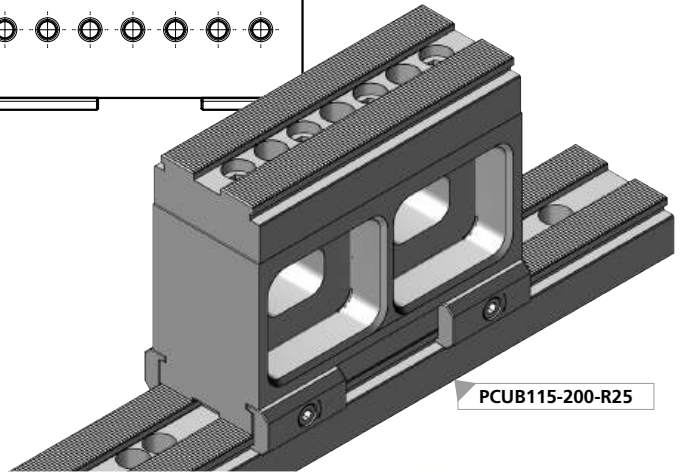
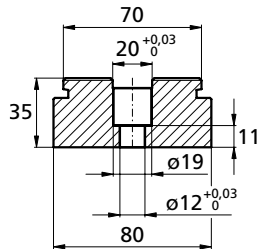
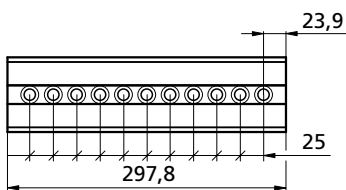

PCUB115-200-R25

## PCUB115-200-R25

- 1 1x TK130323
  - 2 1x PCB25200
  - 3 2x PCSP60R
  - 4 2x PCSP60L
  - 5 2x PCS14
  - 6 2x PCGU2049
  - 7 2x M6X8ISO7380
  - 9 2x TWPAS1240
  - 10 2x M12X40ISO4762
- kg ~13

## PCUB115-300-R25

- 1 1x TK130324
  - 2 1x PCB25300
  - 3 3x PCSP60R
  - 4 3x PCSP60L
  - 5 3x PCS14
  - 6 3x PCGU2049
  - 7 3x M6X8ISO7380
  - 9 2x TWPAS1240
  - 10 4x M12X40ISO4762
- kg ~19,6

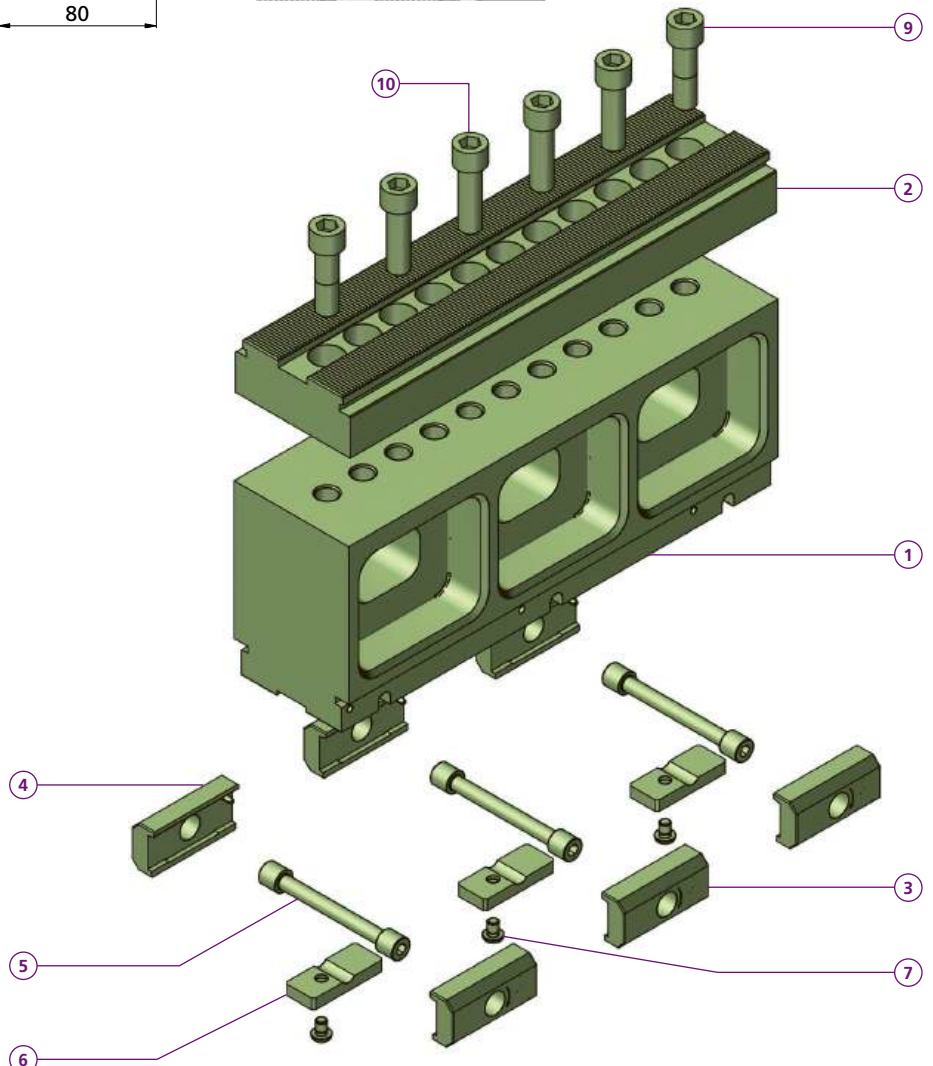

Bestellbeispiel / Ordering example: **PCUB115-300-R25**

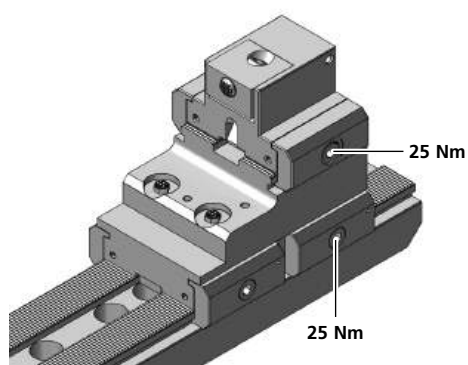
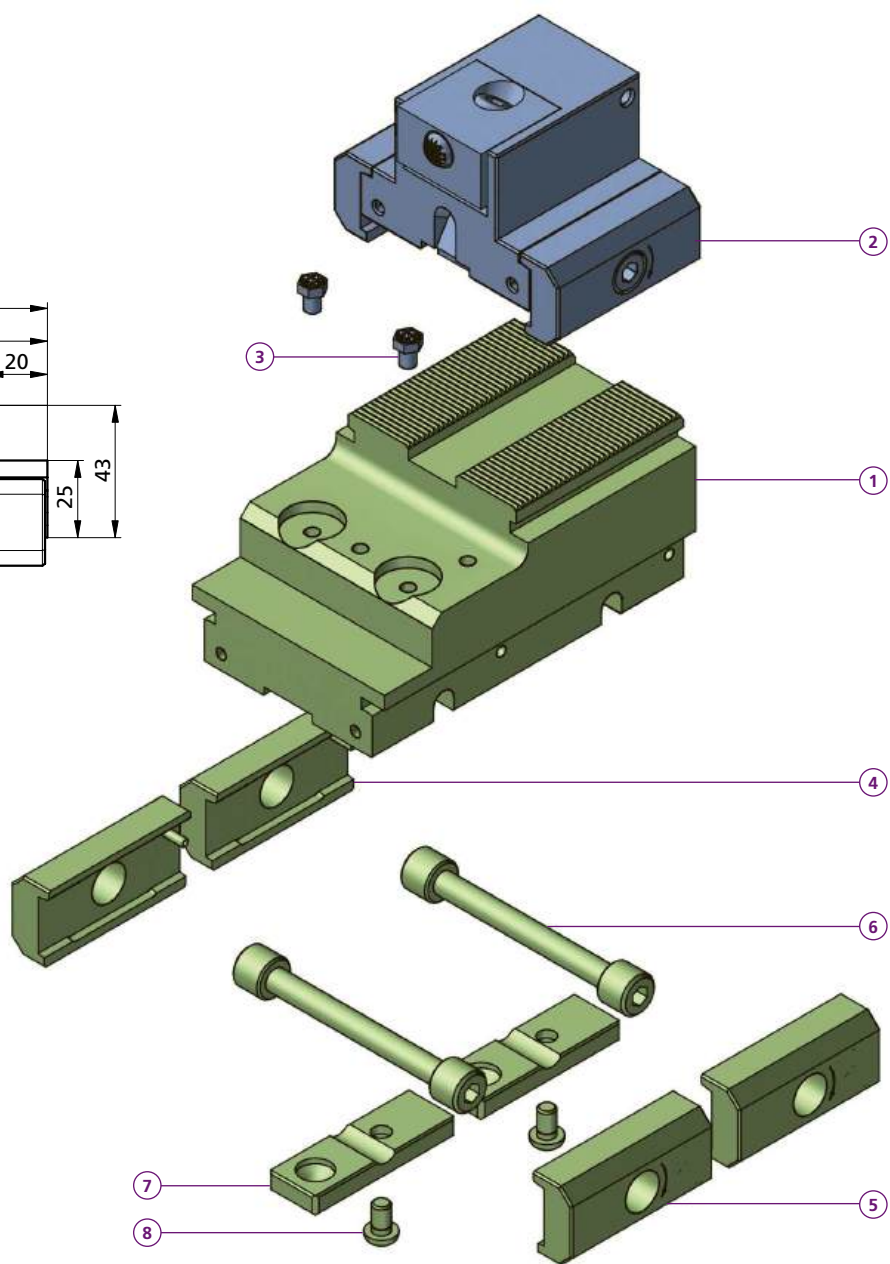
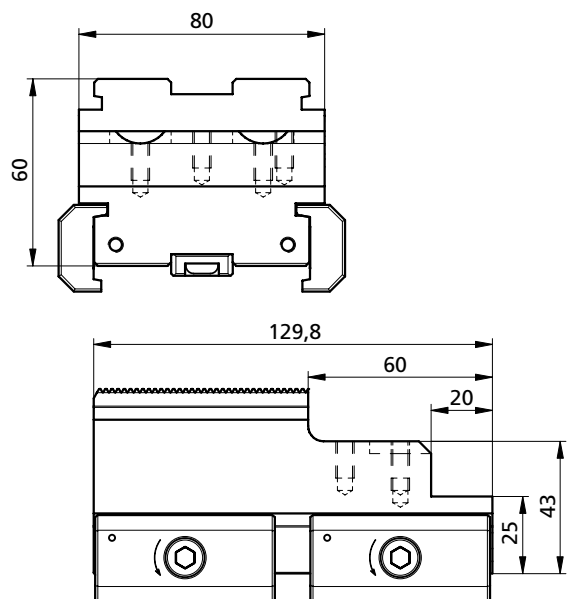

PCUB60-70-130	
①	1x TK130707
②	1x PS1F43N49-60
③	2x CCHMR
④	2x PCSP60L
⑤	2x PCSP60R
⑥	2x PCS14
⑦	2x PCGU2049
⑧	2x M6X8ISO7380
kg	~4,3

p. 64

Zubehör / Accessories p. 337

Bestellbeispiel / Ordering example: PCUB60-70-130

Separat bestellen / Order separately

# Schräge Basisschiene für 5-Achsenmaschinen Slanted base rail for 5-axis machines

**5axes  
powerCLAMP**

Art. Nr.	kg	$\Delta$	H
<b>PCB50207W25</b>	~9,2	25°	131,5
<b>PCB50207W27</b>	~9,5	27,5°	139,7

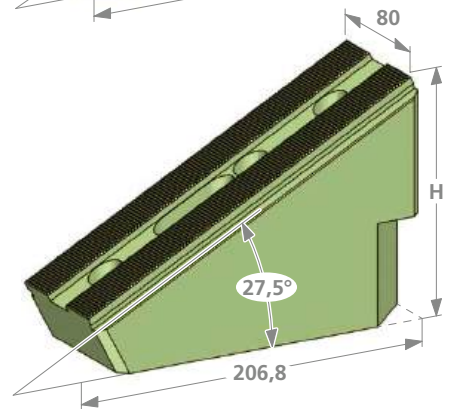
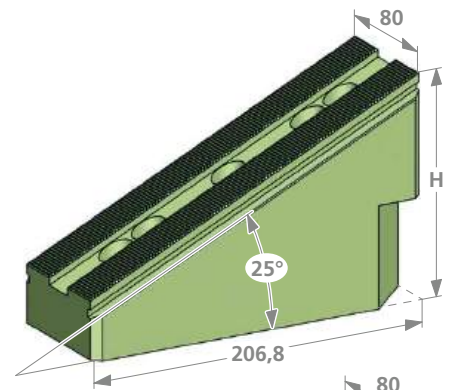
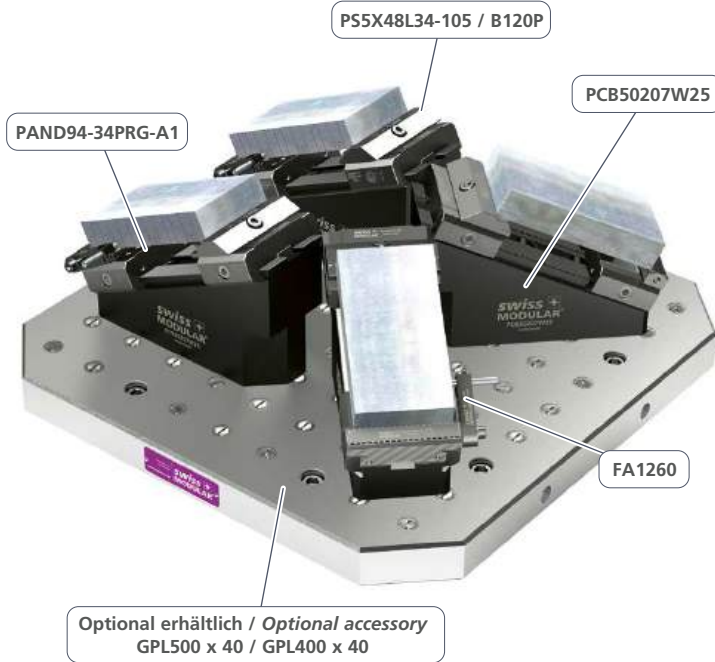

Die Basisschienen können auf einem 50 mm Raster je nach Bedarf parallel oder diagonal platziert werden.  
The base rails can be placed on a 50 mm grid either parallel or diagonal as required.

Art. Nr.	kg	$\Delta$	$\emptyset$	H
<b>PCT30P-153-4</b>	~24	60°	266	152,4

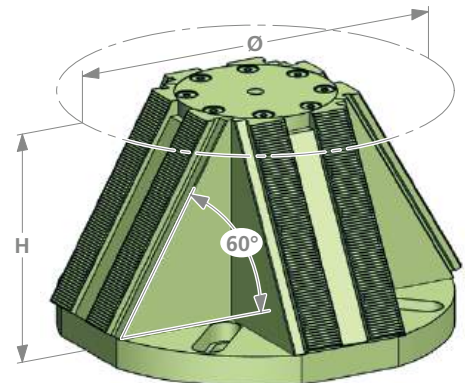
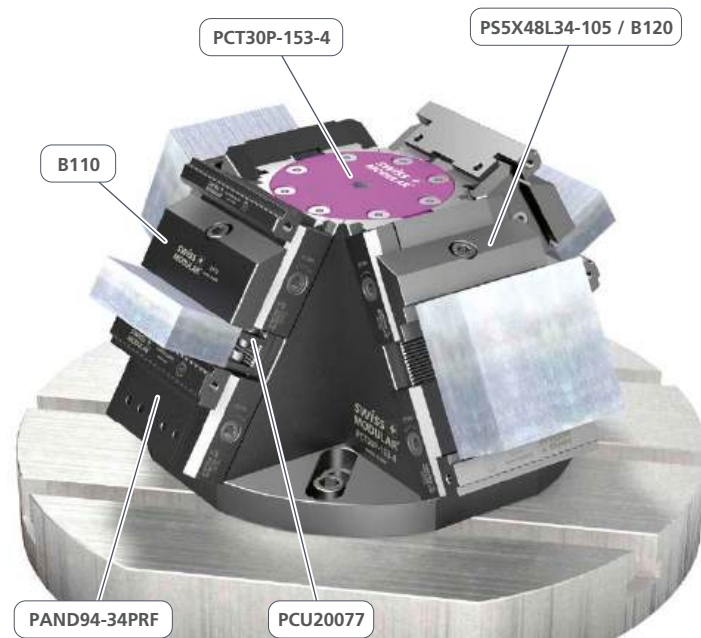

Die Stahl-Mineralgusspyramide verfügt über eine powerCLAMP Schnittstelle und ermöglicht eine kompakte und zugleich flexible 5-Achs-Bearbeitung. Die Module werden in einem Winkel von 60° montiert. Dank dem eingesetzten Mineralguss, hat die Konstruktion ein relativ tiefes Gewicht bei einer hohen Festigkeit.  
The steel mineral casting pyramid has a powerCLAMP interface and enables compact and, at the same time, flexible 5-axis machining. The modules are mounted at an angle of 60°. Due to the mineral cast used, the construction has a relatively low weight with a high rigidity.

# Monobloc Balken & Gegenlager zu Teilapparat Monobloc & Counterbearing for 4th-axis

powerCLAMP

Art. Nr.	kg	L	B
<b>PCT110-300</b>	~24,5	300	110x110
<b>PCT110-350</b>	~27,5	350	110x110
<b>PCT110-400</b>	~31,5	400	110x110
<b>PCT110-450</b>	~35,5	450	110x110
<b>PCT110-500</b>	~39,5	500	110x110
<b>PCT110-550</b>	~43,0	550	110x110
<b>PCT110-600</b>	~47,0	600	110x110
<b>PCT110-650</b>	~51,0	650	110x110
<b>PCT110-700</b>	~55,2	700	110x110

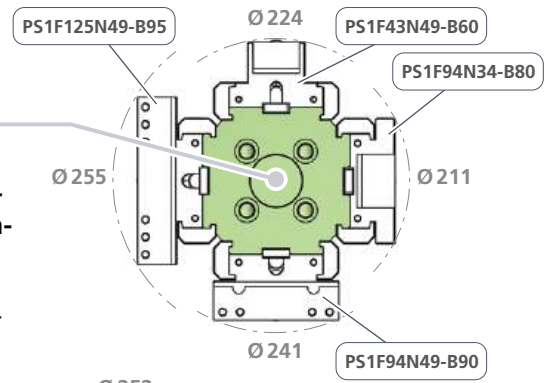
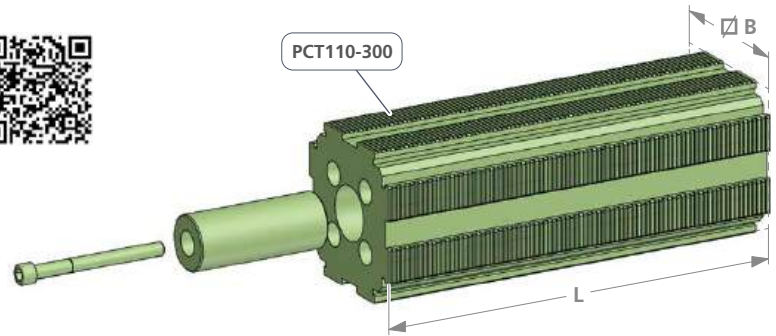

**Störkreise bei verschiedenen Spannmodulen**  
*Workpiece diameter with different clamping modules*

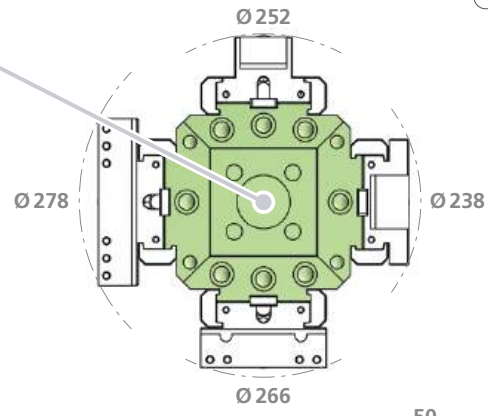

**Stahl-Mineralguss**  
*Steel-exoxy mineral*

Art. Nr.	kg	L	B
<b>PCMT150-700</b>	~83,0	700	150x150
<b>PCMT150-750</b>	~89,0	750	150x150
<b>PCMT150-800</b>	~95,0	800	150x150
<b>PCMT150-850</b>	~101,0	850	150x150

**Gegenlager**  
*Counterbearing*

Art. Nr.	kg
<b>PCGL15050</b>	~8,0

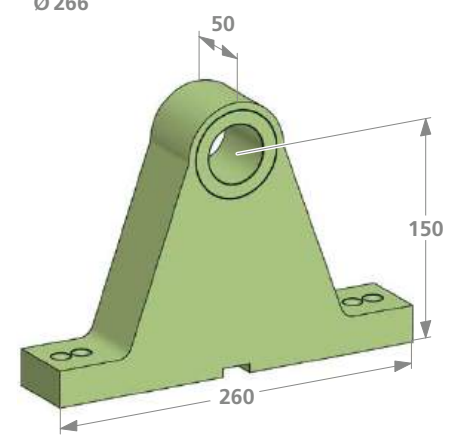

**Reduziert Vibrationen und ist leicht**  
*Reduces vibrations and is light*



Art. Nr.	kg	H	B
<b>PCT110-250MATS</b>	~17	250	110x110
<b>PCT110-300MATS</b>	~21	300	110x110

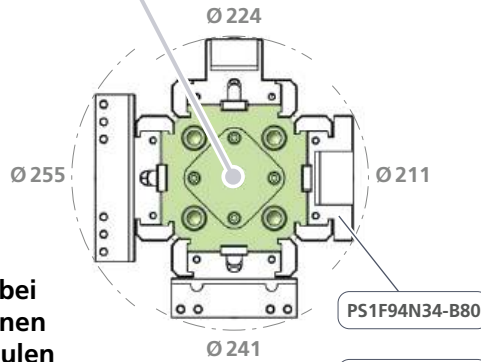
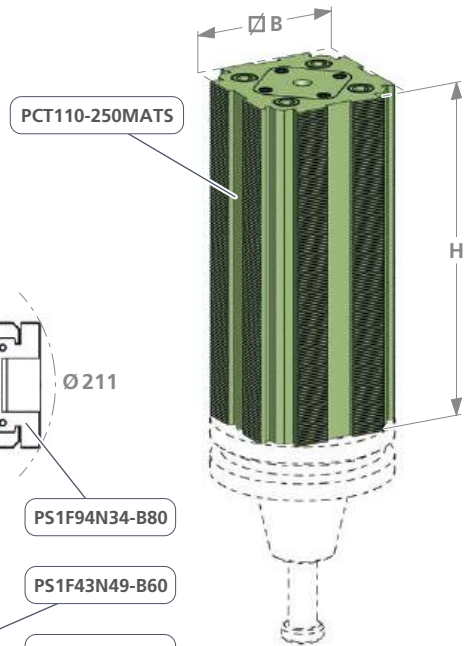

**Störkreise bei verschiedenen Spannmodulen**  
*Workpiece diameter with different clamping modules*

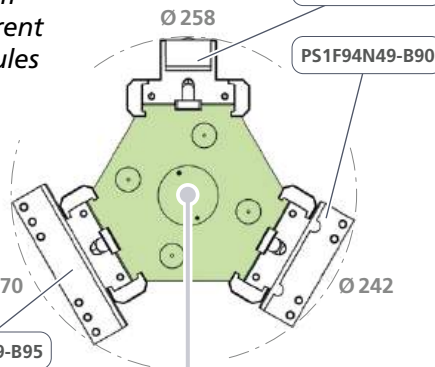

Art. Nr.	kg	H
<b>PCT155-290-3MATS</b>	~30	290

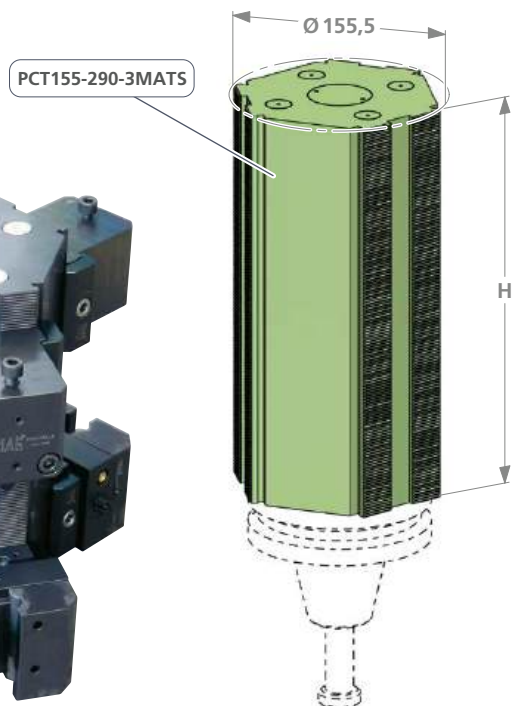

# Spanntürme zu 5-Achs Bearbeitungszentren Clamping fixtures for 5 axis machines

**powerCLAMP**



**powerCLAMP** p. 81



**microCLAMP** p. 178

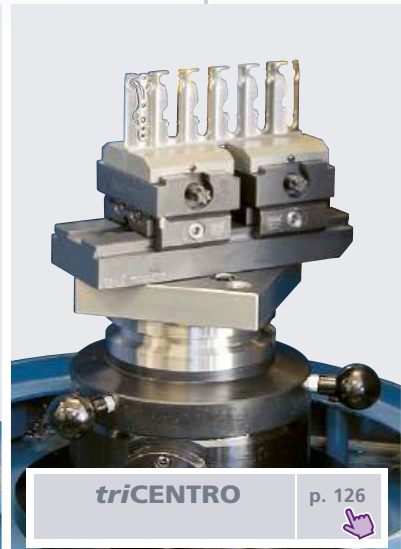

**triCENTRO** p. 126



**powerCLAMP** p. 74, 64

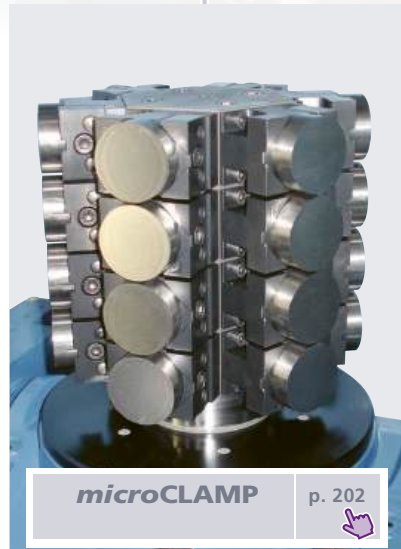

**microCLAMP** p. 202



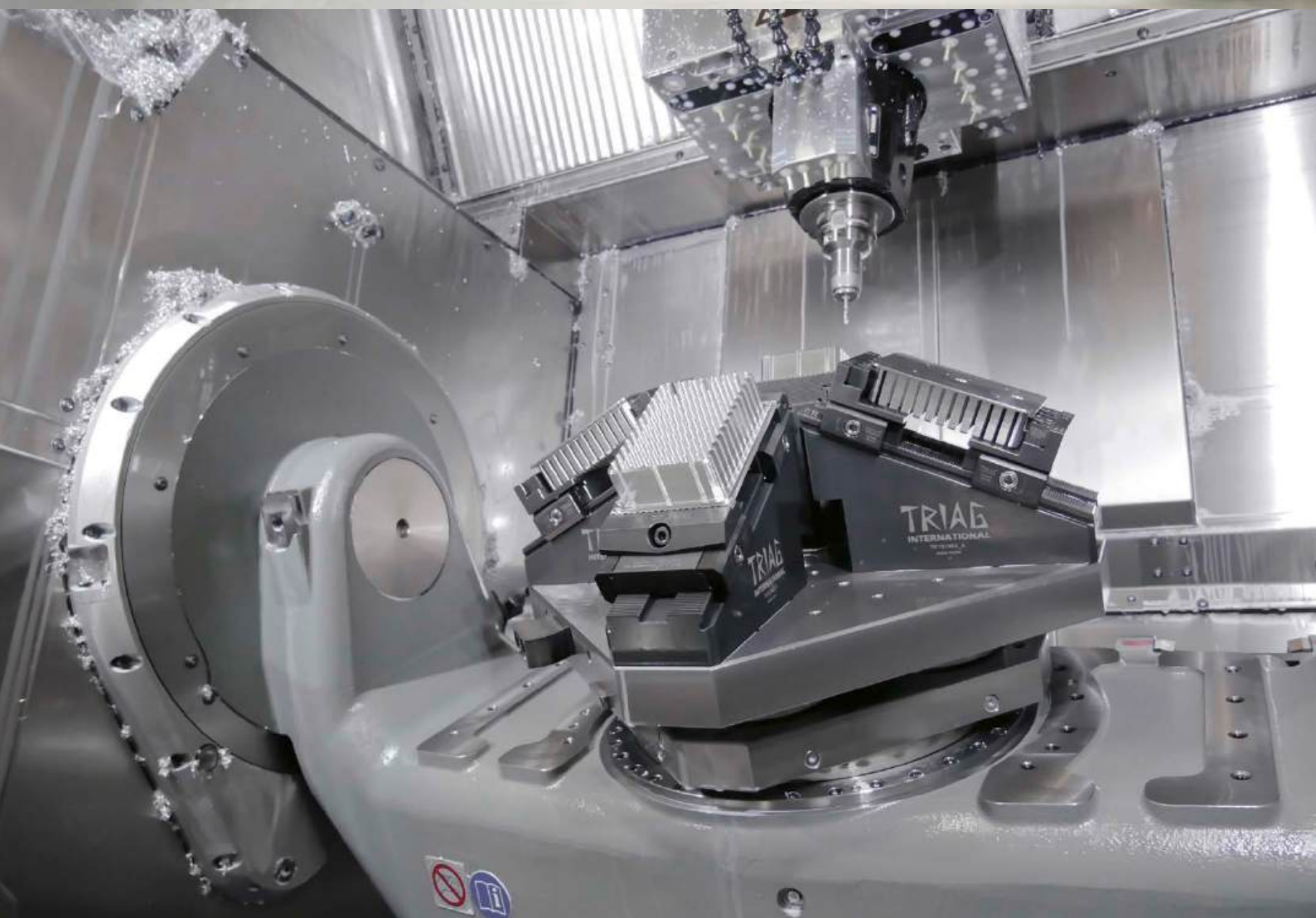

BESTELLBEISPIEL / ORDERING EXAMPLE

1x PCSET18-450A 2x PCSET18-N3 1x PS1X50N62-ER32

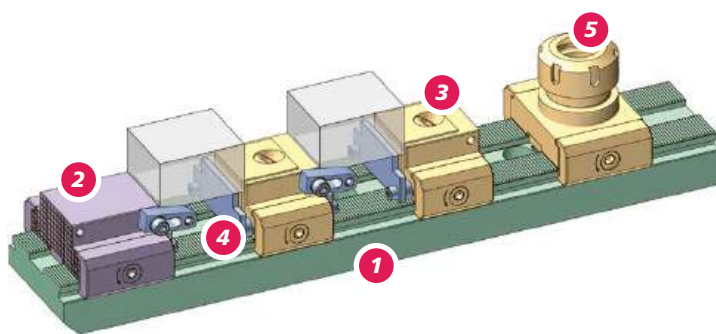
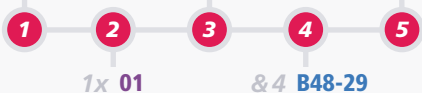

Zu jeder Basisschiene gehört 1 Anschlagmodul «Tabelle 2» nach Ihrer Wahl!  
Each base rail comes with 1 end module "table 2" of your choice!

1 Basisschienen / Base-rails				
PCSET18-250A	PCB2550250	PCSET18-600A	PCB4050600	
PCSET18-350A	PCB4050350	PCSET18-650A	PCB4050650	
PCSET18-400A	PCB4050400	PCSET18-700A	PCB4050700	
PCSET18-450A	PCB4050450	PCSET18-750A	PCB4050750	
PCSET18-500A	PCB4050500	PCSET18-800A	PCB4050800	
PCSET18-550A	PCB4050550			
PCSET18-320B	PCB50320H60			
PCSET18-400B	PCB100400H60			
PCSET18-500B	PCB100500H60			
PCSET18-600B	PCB100600H60			
PCSET18-650B	PCB100650H60			
PCSET18-690B	PCB100690H60			
PCSET18-850B	PCB100850H60			



2 Anschlagmodule / End modules					
48		78		94	
PAND 48-34	PAND 48-49	PAND 78-34	PAND 78-49	PAND 94-34	PAND 94-49
01	02	05	06	07	08
		F = glatt / flat R = geriffelt / double serrated = Direktprägebacken / Direct stamping			
PAND 48-34 PRF-A1	PAND 48-49 PRF-A1			PAND 94-34 PRF-A1	PAND 94-49 PRF-A1
03	04			09	10

5 Dreibackenfutter   Spannzangenmodul   Mini-Zentrischspanner Three-jaw chuck   Collet module   Mini-self centering vise					
PS3X125L87BSET	PS3X100L82BSET	PS3X80L75BSET	PS1X50N62-ER32	PCZ80L40PRG62	PCZ100L50

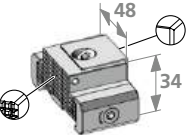
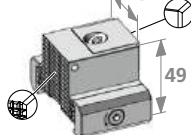
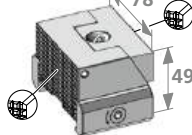
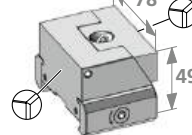
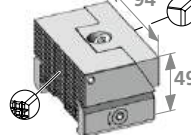
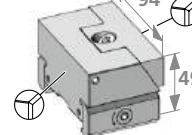
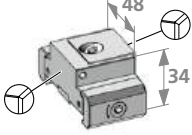
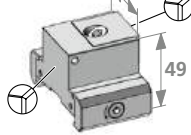
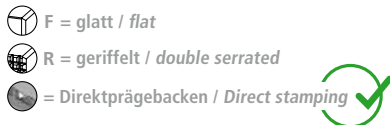
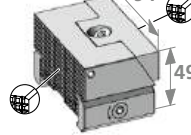

**3 Niederzugspanmodule / Pull down clamp modules**

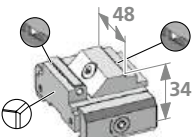
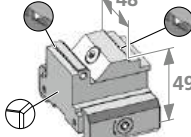
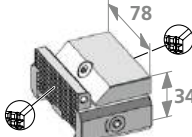
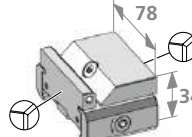
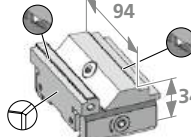
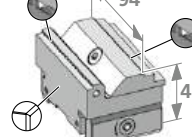
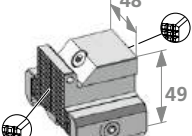
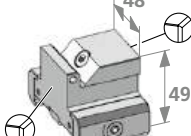
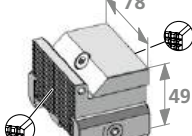
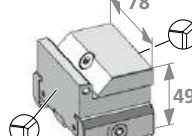
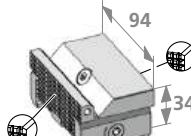
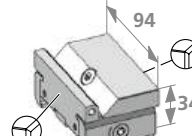
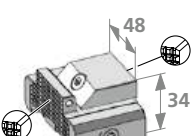
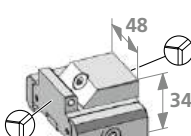
48		78		94	
PS1 R48N34 B80N 	PS1 R48N49 B80N 	PS1 R78N49 B90R78 	PS1 F78N49 B90F78 	PS1 R94N49 B90 	PS1 F94N49 B90 
<b>PCSET18-N1</b>	<b>PCSET18-N2</b>	<b>PCSET18-N5</b>	<b>PCSET18-N6</b>	<b>PCSET18-N7</b>	<b>PCSET18-N8</b>
PS1 F48N34 B80N 	PS1 F48N49 B80N 			PS1 R94N49 B93 	
<b>PCSET18-N3</b>	<b>PCSET18-N4</b>			<b>PCSET18-N9</b>	

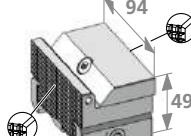
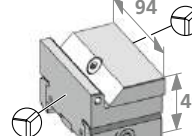
**Linearspanmodule / Linear clamp modules**

PS1 PF 48L34 B115P 	PS1 PF 48L49 B115P 	PS1 R78L34 B141 	PS1 F78L34 B140 	PS1 PF 94L34 B120P 	PS1 PF 94L49 B120P 
<b>PCSET18-L1</b>	<b>PCSET18-L2</b>	<b>PCSET18-L5</b>	<b>PCSET18-L6</b>	<b>PCSET18-L9</b>	<b>PCSET18-L11</b>
PS1 R48L49 B106 	PS1 F48L49 B105 	PS1 R78L49 B141 	PS1 F78L49 B140 	PS1 R94L34 B111 	PS1 F94L34 B110 
<b>PCSET18-L3</b>	<b>PCSET18-L4</b>	<b>PCSET18-L7</b>	<b>PCSET18-L8</b>	<b>PCSET18-L12</b>	<b>PCSET18-L13</b>
PS1 R48L34 B106 	PS1 F48L34 B105 	<p>Bei jedem Niederzug und Linear Spanmodule sind 2 Parallelunterlagen nach Ihrer Wahl und 1 Fräsanschlag enthalten.</p>  <p>Each pull-down and linear clamping module includes 2 parallels of your choice and 1 milling buffer.</p>		PS1 R94L49 B111 	PS1 F94L49 B110 
<b>PCSET18-L16</b>	<b>PCSET18-L17</b>			<b>PCSET18-L14</b>	<b>PCSET18-L15</b>

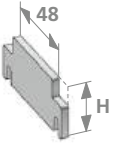
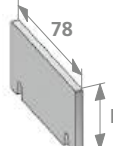
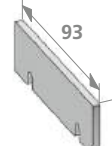
**4 Parallelunterlagen / Steel parallels**

48	78	94
 <b>PCU29047</b> <b>H</b> PCU 20 047 PCU 24 047 <b>PCU29047</b> PCU 31 047 PCU 34 047 PCU 39 047 PCU 44 047 PCU 46 047 <b>B48- ...</b>	 <b>PCU39077</b> <b>H</b> PCU 20 077 PCU 24 077 PCU 29 077 PCU 31 077 PCU 34 077 <b>PCU39077</b> PCU 44 077 <b>B78- ...</b>	 <b>PCU29093</b> <b>H</b> PCU 14 093 PCU 20 093 PCU 24 093 <b>PCU29093</b> PCU 31 093 PCU 34 093 PCU 39 093 PCU 44 093 PCU 46 093 PCU 47 093 <b>B94- ...</b>
<b>Fräsanschlag / Milling buffer</b>		
 <b>FA1240</b>		
<b>1 x Inklusive / Included</b>		



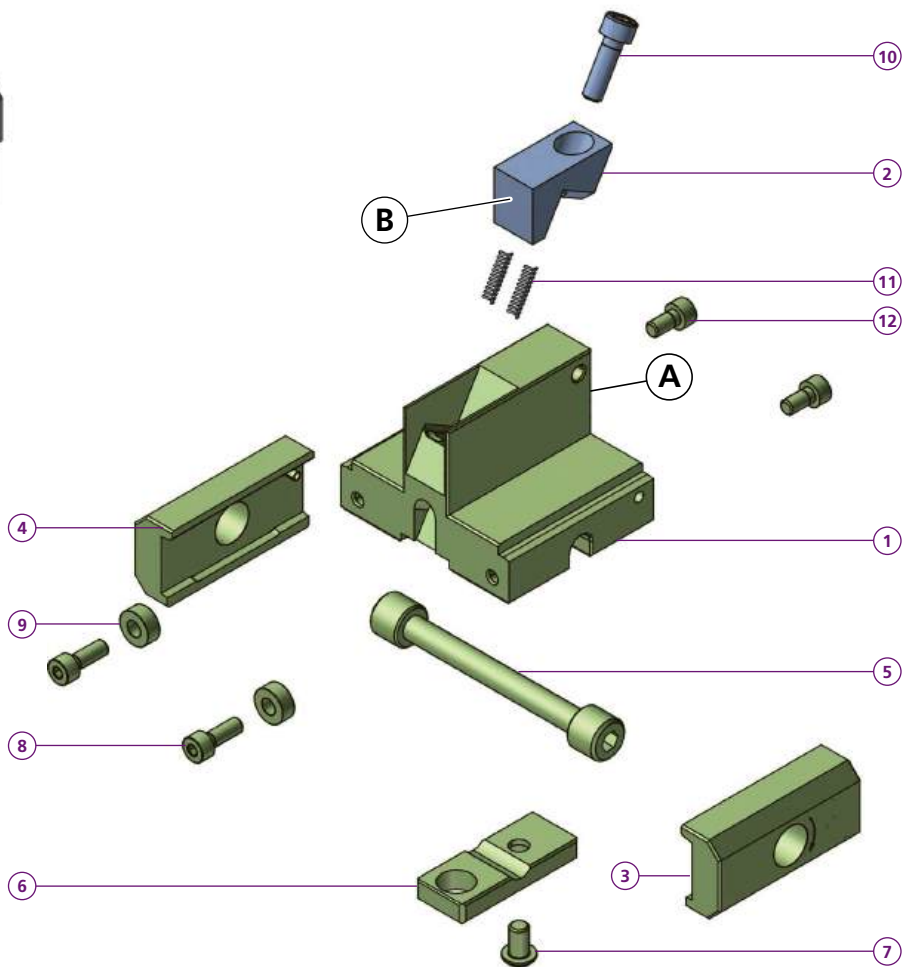
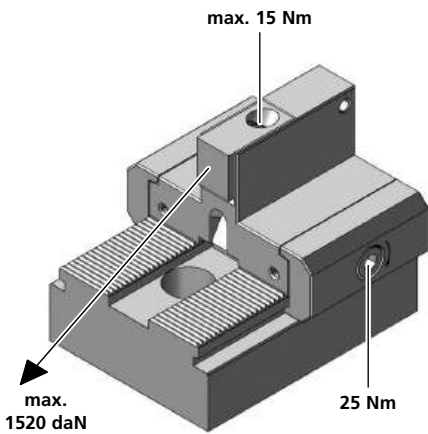
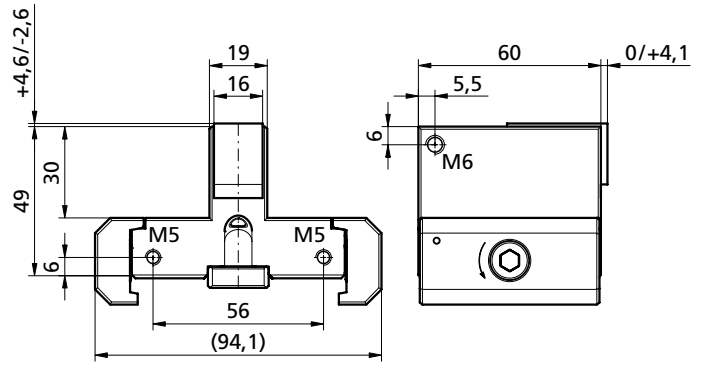
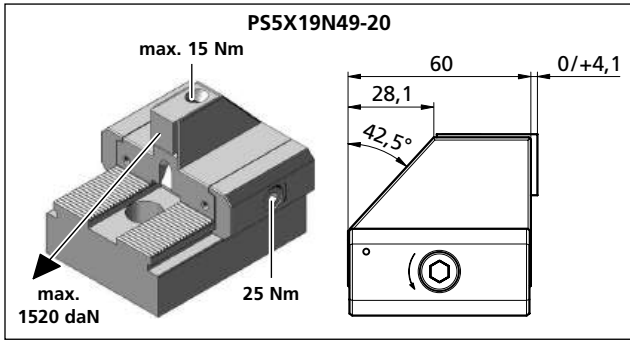

	<b>PS5X19N49-20</b>
1	1x TF140449
9	2x PCD005
8	2x M5X14ISO4762
kg	~1,1
	<b>PS1F19N49-20</b>
1	1x TF150961
	<b>PS1R19N49-20</b>
1	1x TF140448
2	1x
3	1x PCSP60R
4	1x PCSP60L
5	1x PCS14
6	1x PCGU2049
7	1x M6X8ISO7380
8	2x M5X14ISO4762
9	2x PCD005
10	1x M6X20ISO4762
11	2x FED0418
12	2x M5X10ISO4762
kg	~1,2

	<b>B20</b>	<b>B21</b>	<b>B22</b>
C	16	16	16
H	20	20	20
L	19	19	19
D	6,5	6,5	6,5
ø	12	12	12
i	HV700	HV700	*
	x0,2mm	x0,2mm	
kg	~0,06	~0,06	~0,06

Bestellbeispiel / Ordering example: 1x PS1R19N49-20 & 1x B21

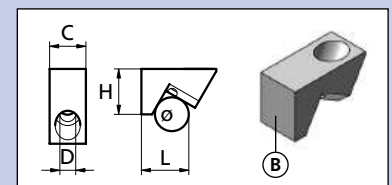

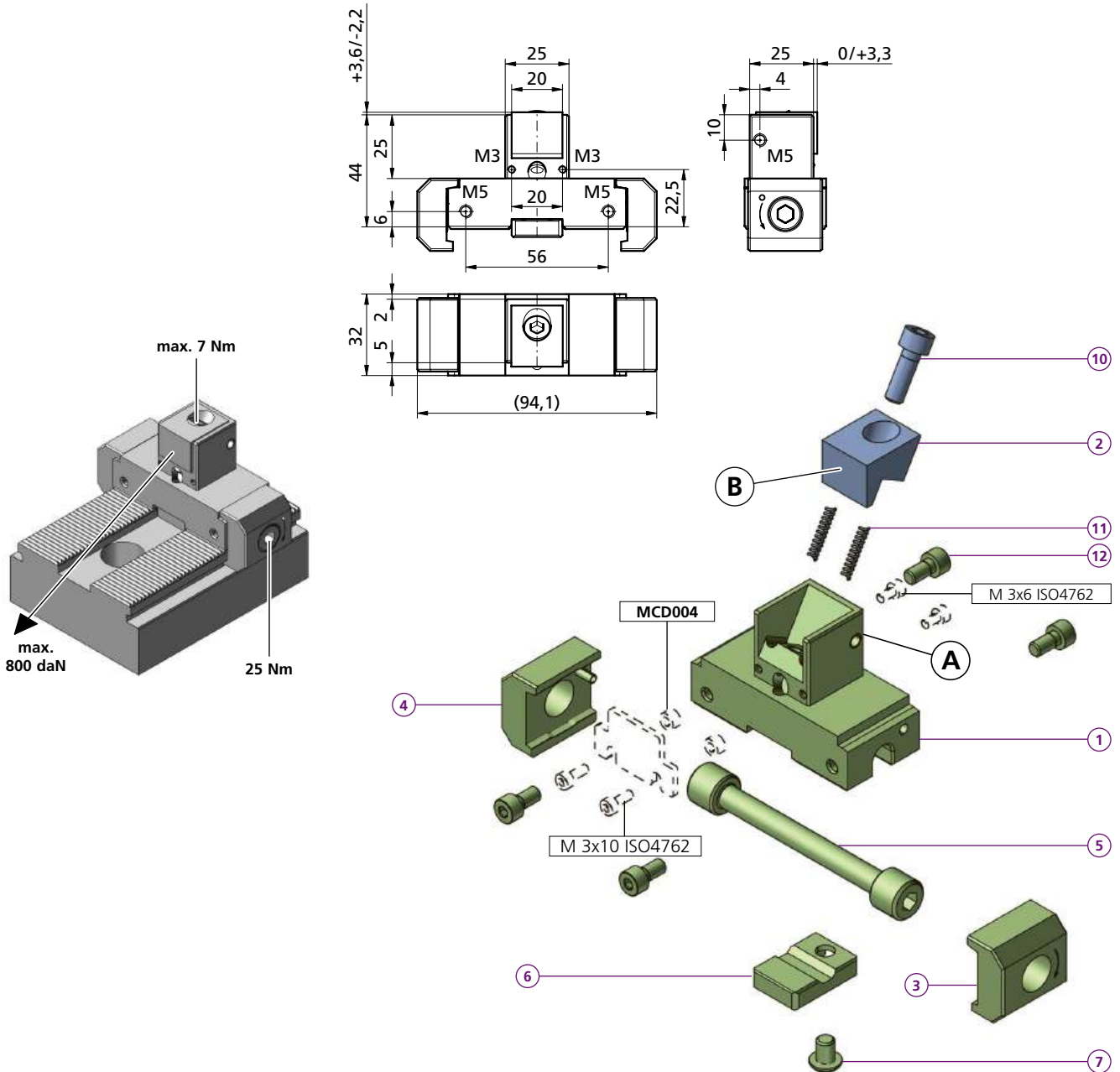

<b>PS1F25N44-13</b>	
1	1x TF150960
<b>PS1R25N44-13</b>	
1	1x TF140450
2	1x
3	1x PCSP30R
4	1x PCSP30L
5	1x PCS14
6	1x PCGU2030
7	1x M6X8ISO7380
<b>kg</b> ~0,6	

<b>Bestellbeispiel / Ordering example: 1x PS1R25N44-13 &amp; 1x B14</b>				
	<b>B13</b>	<b>B14</b>	<b>B15</b>	<b>B16</b>
C	20	20	20	20
H	16	16	16	16
L	13,8	13,8	13,8	19
D	6,5	6,5	6,5	6,5
e	10	10	10	10
i	HV700	HV700	*	*
	x0,2mm	x0,2mm		
kg	~0,05	~0,05	~0,05	~0,06

	H	B	N	kg
MCU11037	11	23	2	~0,004
MCU15037	15	23	2	~0,006
MCU18037	18	23	2	~0,008
MCU20037	20	23	2	~0,008
MCU22537	22,5	23	2	~0,008

- 2x M3X10ISO4762
- 2x M3X6ISO4762
- 2x MCD004

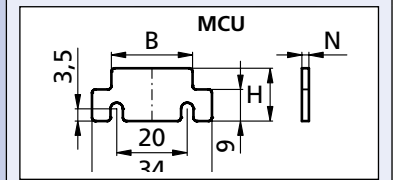

\* = weicher Stahl / soft steel

PS1R/F26N49-26

PS5X26N49-26

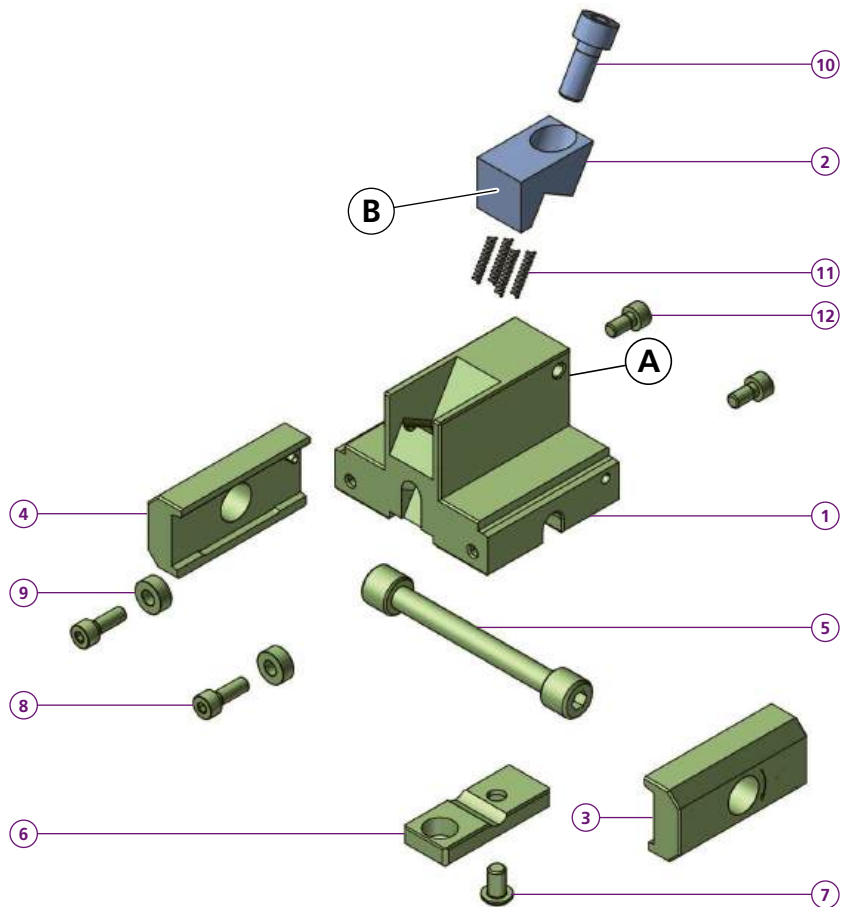
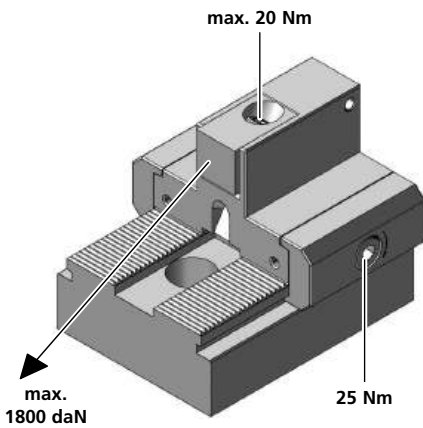
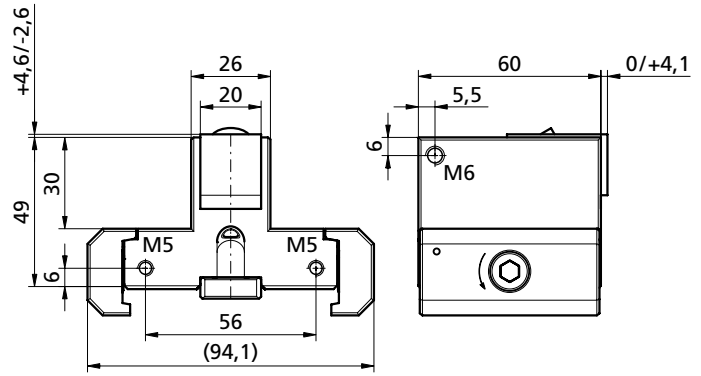
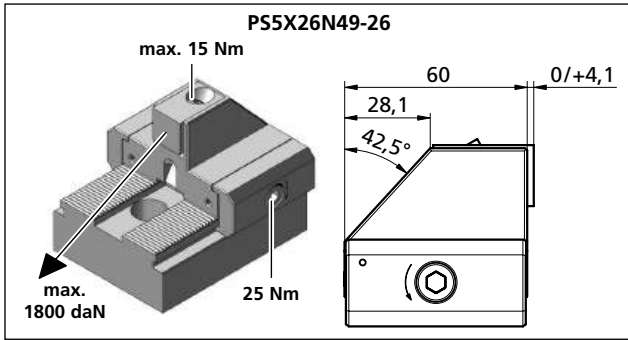

<b>PS5X26N49-26</b>	
1	1x TF140453
9	2x PCD005
8	2x M5X14ISO4762
kg	~1,1
<b>PS1F26N49-26</b>	
1	1x TF140451
<b>PS1R26N49-26</b>	
1	1x TF140452
2	1x
3	1x PCSP60R
4	1x PCSP60L
5	1x PCS14
6	1x PCGU2049
7	1x M6X8ISO7380
8	2x M5X14ISO4762
9	2x PCD005
10	1x M8X20ISO4762
11	4x FED0418
12	2x M5X10ISO4762
kg	~1,2

<b>B</b>	<b>B26</b>	<b>B27</b>	<b>B28</b>
<b>C</b>	20	20	20
<b>H</b>	20	20	20
<b>L</b>	19	19	19
<b>D</b>	9	9	9
<b>e</b>	12	12	12
<b>i</b>	HV700	HV700	*
	x0,2mm	x0,2mm	
<b>kg</b>	~0,07	~0,07	~0,07

Bestellbeispiel / Ordering example: 1x PS1R26N49-26 & 1x B26

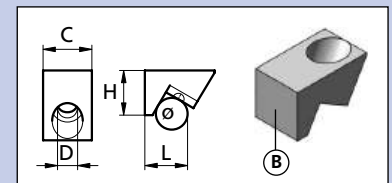

Separat bestellen / Order separately

PS1R/F34N49-45

PS5X34N49-45

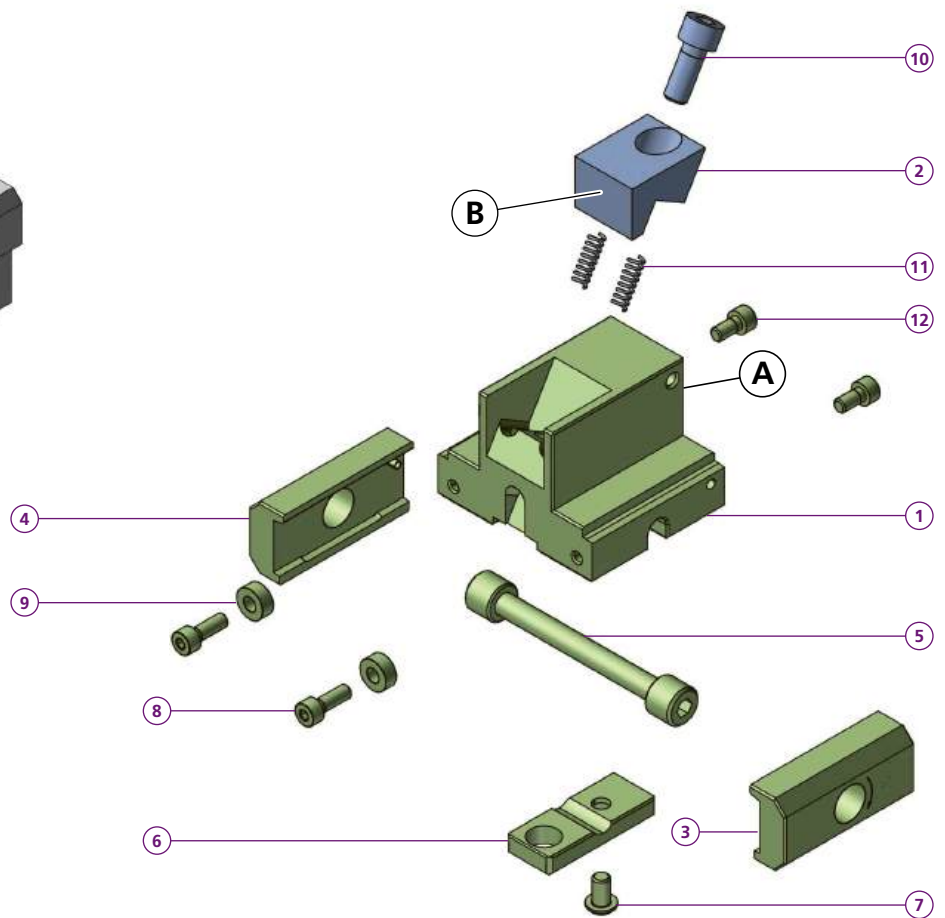
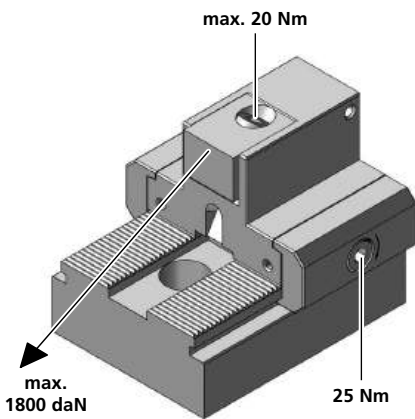
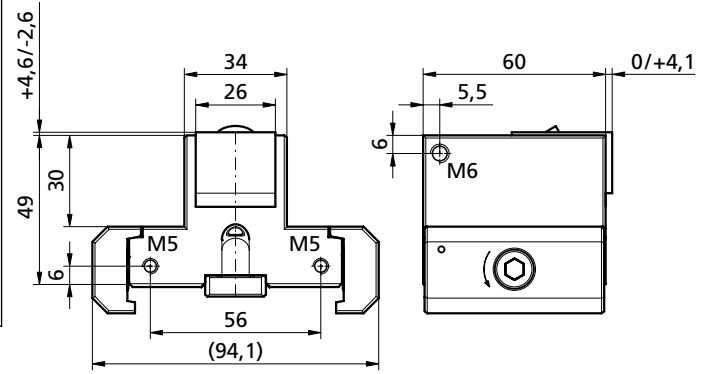
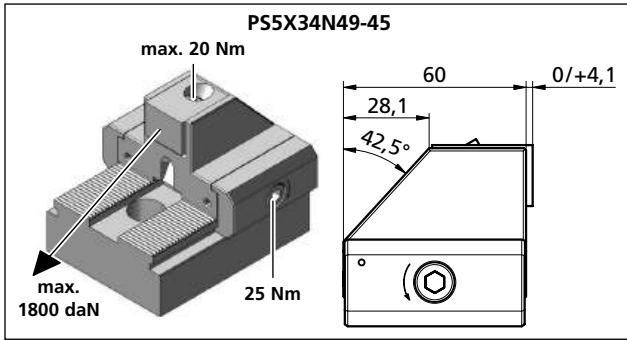

<b>PS5X34N49-45</b>	
1	1x TF140455
9	2x PCD005
8	2x M5X14ISO4762
kg	~1,2
<b>PS1F34N49-45</b>	
1	1x TF191071
<b>PS1R34N49-45</b>	
1	1x TF140454
2	1x
3	1x PCSP60R
4	1x PCSP60L
5	1x PCS14
6	1x PCGU2049
7	1x M6X8ISO7380
8	2x M5X14ISO4762
9	2x PCD005
10	1x M8X20ISO4762
11	2x FED0618
12	2x M5X10ISO4762
kg	~1,3

Bestellbeispiel / Ordering example: 1x PS5X34N49-45 & 1x B47HM

	B45	B46	B47	B47HM
C	26	26	26	26
H	20	20	20	20
L	19	19	19,1	19,1
D	9	9	9	9
e	12	12	12	12
i	HV700	HV700	*	HM
	x0,2mm	x0,2mm		
kg	~0,1	~0,1	~0,1	~0,1

\* = weicher Stahl / soft steel

HM = Hartmetallbeschichtet / Carbide coated

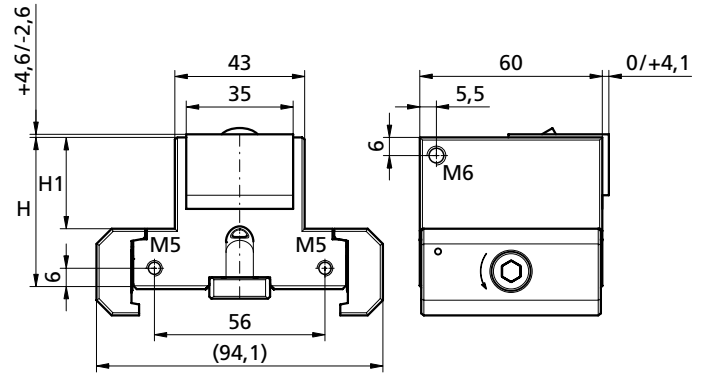
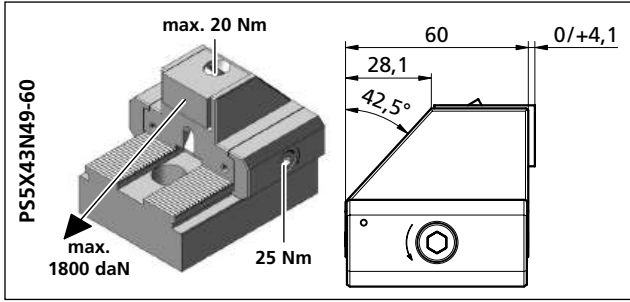

- PS5X43N49-60**
- 1x TF140458
  - 2x PCD005
  - 2x M5X14ISO4762
- kg ~1,3
- PS1F43N49-60**
- 1x TF140456
- PS1R43N49-60**
- 1x TF140457
  - 1x \_\_\_\_\_
  - 1x PCSP60R
  - 1x PCSP60L
  - 1x PCS14
  - 1x PCGU2049
  - 1x M6X8ISO7380
  - 2x M5X14ISO4762
  - 2x PCD005
  - 1x M8X20ISO4762
  - 2x FED0618
  - 2x M5X10ISO4762
- H = 49  
H1 = 30  
kg ~1,4
- PS1F43N62-60**
- 1x TF140459
- PS1R43N62-60**
- 1x TF140460
- H = 62  
H1 = 43  
kg ~1,7

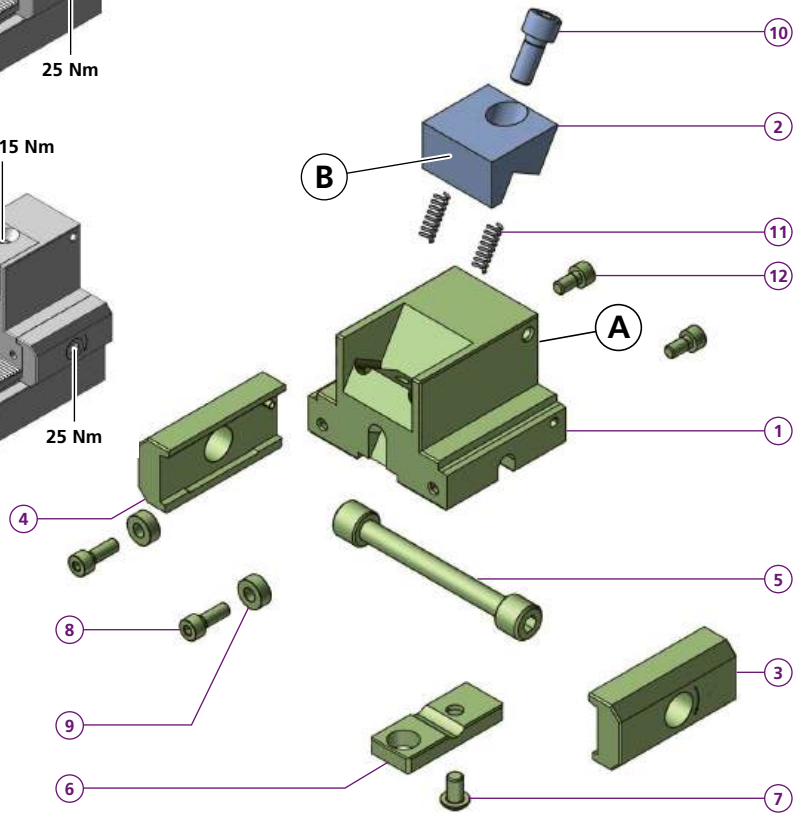
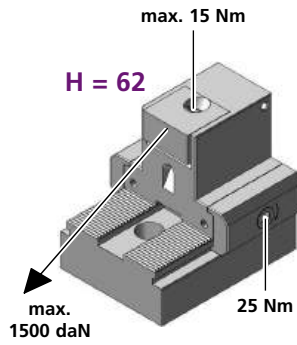
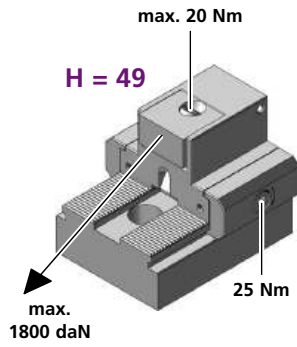

Bestellbeispiel / Ordering example: 1x PS1R43N49-60 & 1x B61

	B58	B60	B61	B62	B62HM	B65	B66	B67	B68	B69	B77	B79F	B79R
<b>C</b>	35	35	35	35	35	35	35	35	35	35	35	35	35
<b>H</b>	20	20	20	20	20	20	20	20	20	25	20	20	20
<b>L</b>	26	19	19	19	19	19	19	24	26	22	22	25	25
<b>D</b>	9	9	9	9	9	9	9	9	9	9	9	9	9
<b>o</b>	12	12	12	12	12	12	12	12	12	12	12	12	12
<b>i</b>	ALU	56HRC	56HRC	*	HM	HV700 x0,2mm	HV700 x0,2mm	HV700 x0,2mm	*	*	56HRC	HV700 x0,2mm	HV700 x0,2mm
<b>kg</b>	~0,07	~0,12	~0,12	~0,12	~0,12	~0,12	~0,12	~0,14	~0,15	~0,15	~0,12	~0,18	~0,18

**B58**

**B60, B61, B62, B62HM**

**B65, B66, B67**

**B68**

**B77**

**B79F, B79R**

**B69**  
M5X10ISO4762

FED 0628

Separat bestellen / Order separately

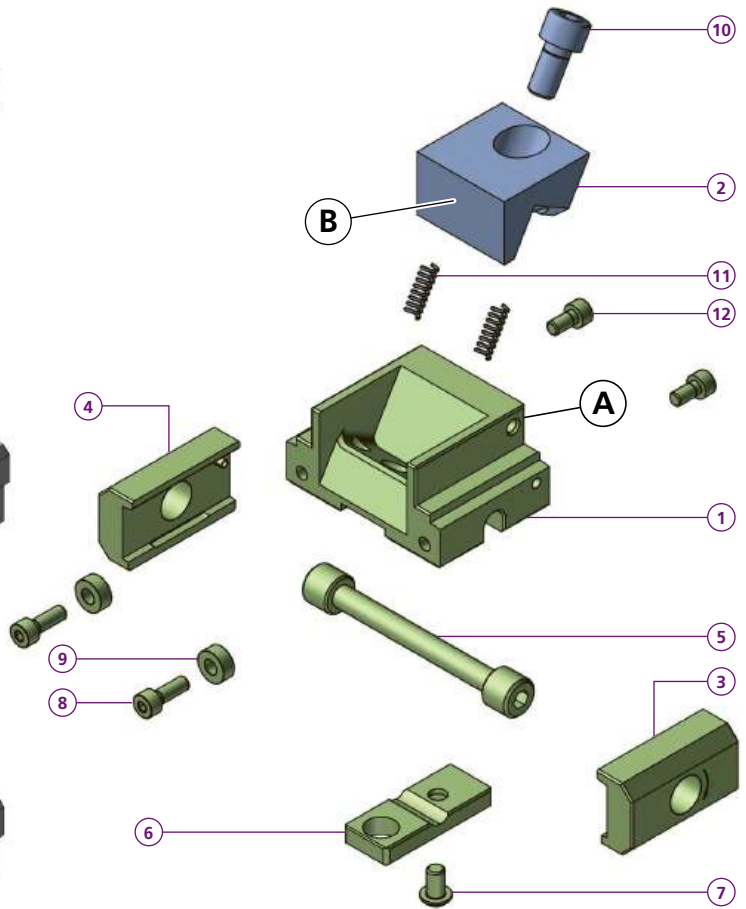
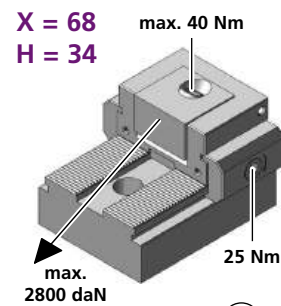
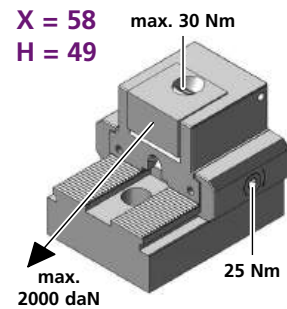
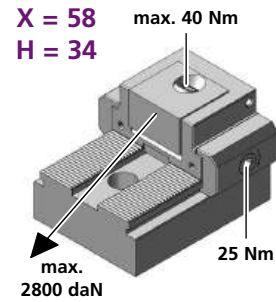
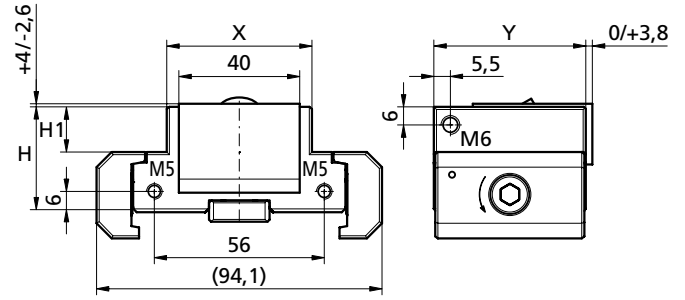
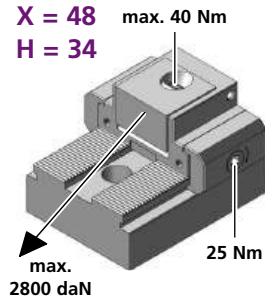

- PS1F48N34-80**
- 1 1x TF140461
- PS1R48N34-80**
- 1 1x TF140462
  - 2 1x
  - 3 1x PCSP50R
  - 4 1x PCSP50L
  - 5 1x PCS14
  - 6 1x PCGU2049
  - 7 1x M6X8ISO7380
  - 8 2x M5X14ISO4762
  - 9 2x PCD005
  - 10 1x M10X25ISO4762
  - 11 2x FED0618
  - 12 2x M5X10ISO4762
- X = 48  
H = 34  
H1 = 15  
Y = 50  
kg ~0,9

- PS1F58N34-80**
- 1 1x TF140463
- PS1R58N34-80**
- 1 1x TF140464
- X = 58  
H = 34  
H1 = 15  
Y = 50  
kg ~0,9

- PS1R58N49-80**
- 1 1x TK120129
  - 3 1x PCSP60R
  - 4 1x PCSP60L
- X = 58  
H = 49  
H1 = 30  
Y = 60  
kg ~1,6

- PS1F68N34-80**
- 1 1x TF140465
- PS1R68N34-80**
- 1 1x TF140466
- X = 68  
H = 34  
H1 = 15  
Y = 50  
kg ~1,0

Bestellbeispiel / Ordering example: 1x PS1F68N34-80 & 1x B82HM

	B80	B80N	B81	B82	B82L33	B82HM	B83	B84	B89F	B89R
C	40	40	40	40	40	40	40	40	40	40
H	25	25	25	25	25	25	25	25	25	25
L	22	22	22	22,2	33	22,2	22	26,3	29	29
D	11	11	11	11	11	11	11	11	11	11
ø	15	15	15	15	15	15	15	15	15	15
i	56HRC	HV700 x0,2mm	56HRC	*	*	56HRC	HV700 x0,2mm	*	HV700 x0,2mm	HV700 x0,2mm
kg	~0,2	~0,2	~0,2	~0,2	~0,28	~0,2	~0,2	~0,2	~0,24	~0,24

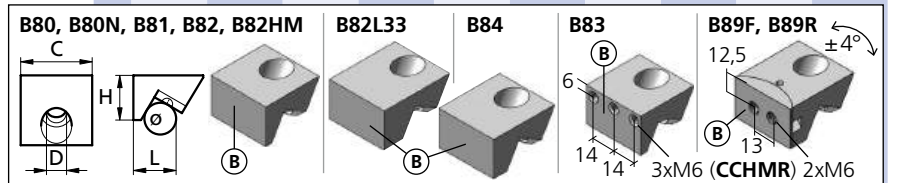

\* = weicher Stahl / soft steel

HM = Hartmetallbeschichtet / Carbide coated

Separat bestellen / Order separately

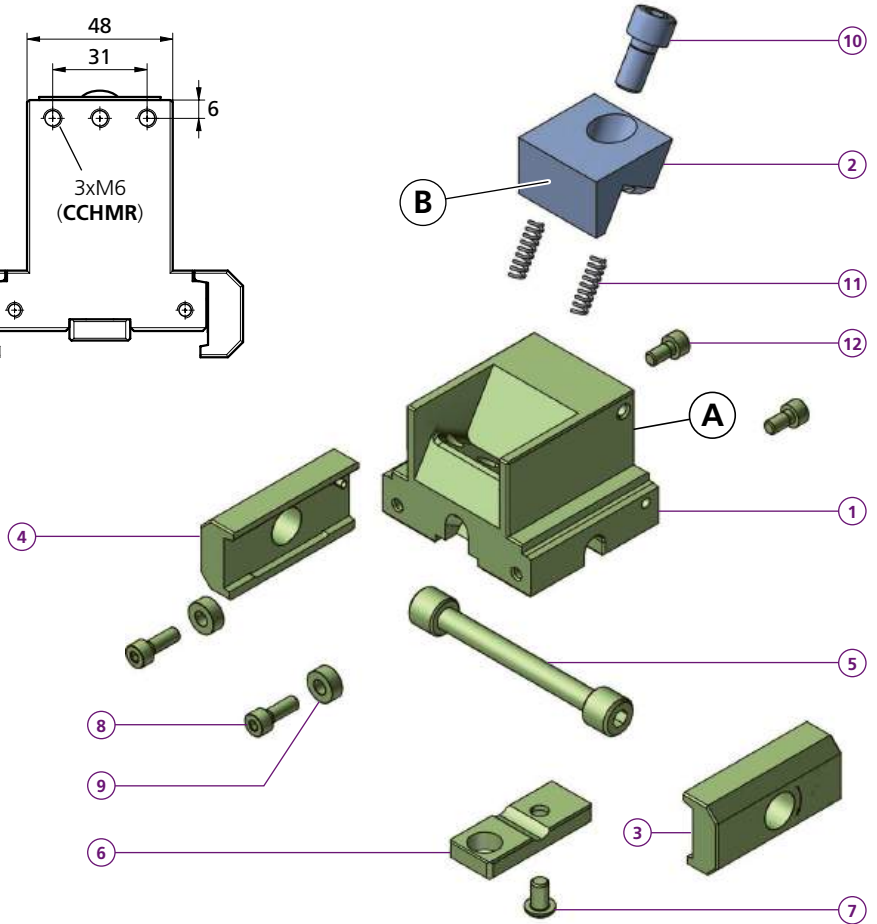
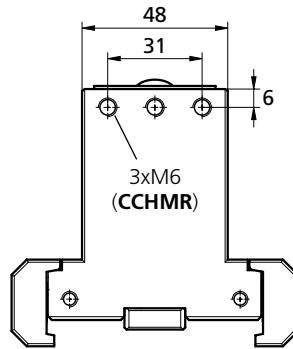
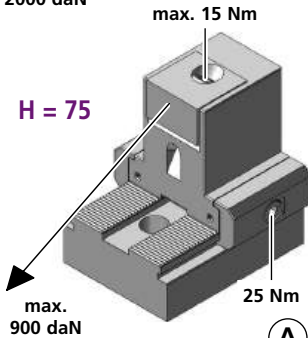
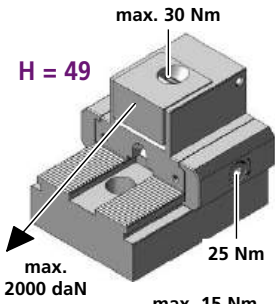
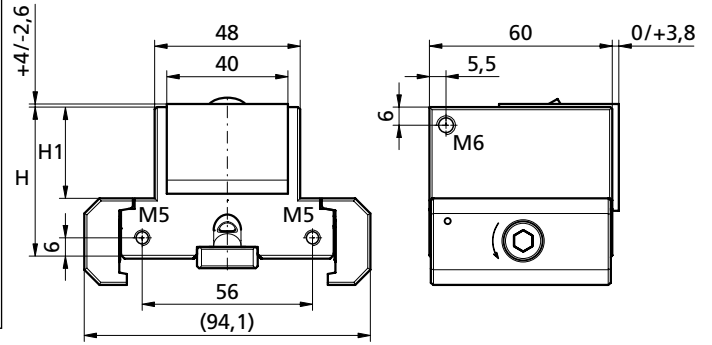
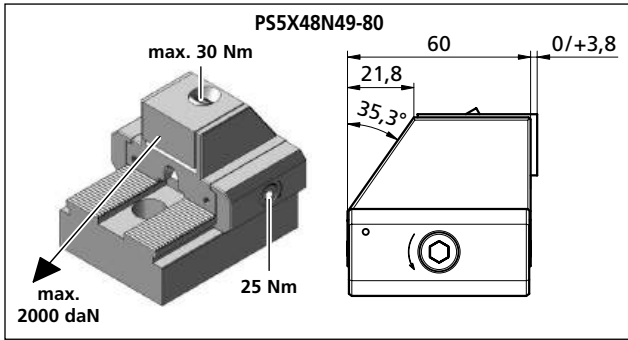

<b>PS5X48N49-80</b>
1x TF140469
2x PCD005
2x M5X14ISO4762
kg ~1,3
<b>PS1F48N49-80</b>
1x TF140467
<b>PS1R48N49-80</b>
1x TF140468
1x
1x PCSP60R
1x PCSP60L
1x PCS14
1x PCGU2049
1x M6X8ISO7380
2x M5X14ISO4762
2x PCD005
1x M10X25ISO4762
2x FED0618
2x M5X10ISO4762
H = 49
H1 = 30
kg ~1,4

<b>PS1R48N75-80</b>
1x TF140471
H = 75
H1 = 56
kg ~2,0

Bestellbeispiel / Ordering example: 1x PS1F48N49-80 & 1x B80

	B80	B80N	B81	B82	B82L33	B82HM	B83	B84	B89F	B89R
C	40	40	40	40	40	40	40	40	40	40
H	25	25	25	25	25	25	25	25	25	25
L	22	22	22	22,2	33	22,2	22	26,3	29	29
D	11	11	11	11	11	11	11	11	11	11
ø	15	15	15	15	15	15	15	15	15	15
i	56HRC	HV700 x0,2mm	56HRC	*	*	56HRC	HV700 x0,2mm	*	HV700 x0,2mm	HV700 x0,2mm
kg	~0,2	~0,2	~0,2	~0,2	~0,28	~0,2	~0,2	~0,2	~0,24	~0,24

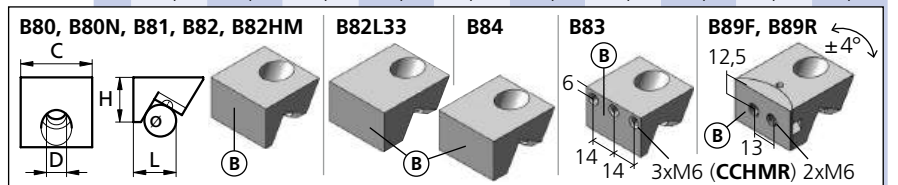

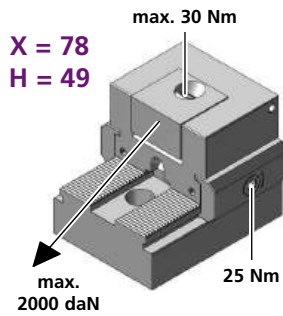
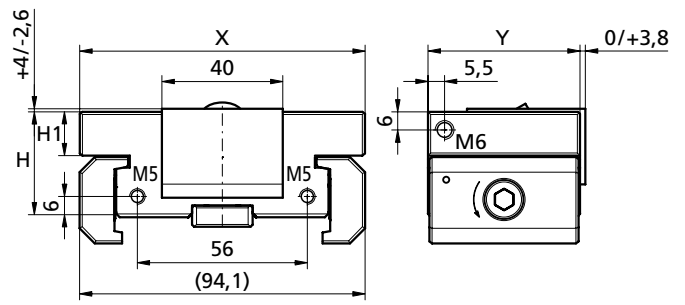
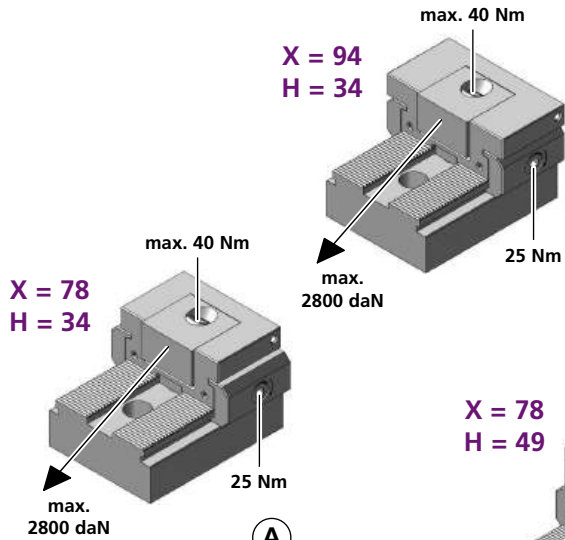

**PS1F78N34-80**

1x TF140472

**PS1R78N34-80**

1x TF140473

1x

1x PCSP50R

1x PCSP50L

1x PCS14

1x PCGU2049

1x M6X8ISO7380

2x M5X14ISO4762

2x PCD005

1x M10X25ISO4762

2x FED0618

2x M5X10ISO4762

X = 48

H = 34

H1 = 15

Y = 50

kg ~1,1

**PS1F94N34-80**

1x TF140476

**PS1R94N34-80**

1x TF140477

X = 94

H = 34

H1 = 15

Y = 50

kg ~1,1

**PS1F78N49-80**

1x TF140474

**PS1R78N49-80**

1x TF140475

1x PCSP60R

1x PCSP60L

X = 78

H = 49

H1 = 30

Y = 60

kg ~1,8

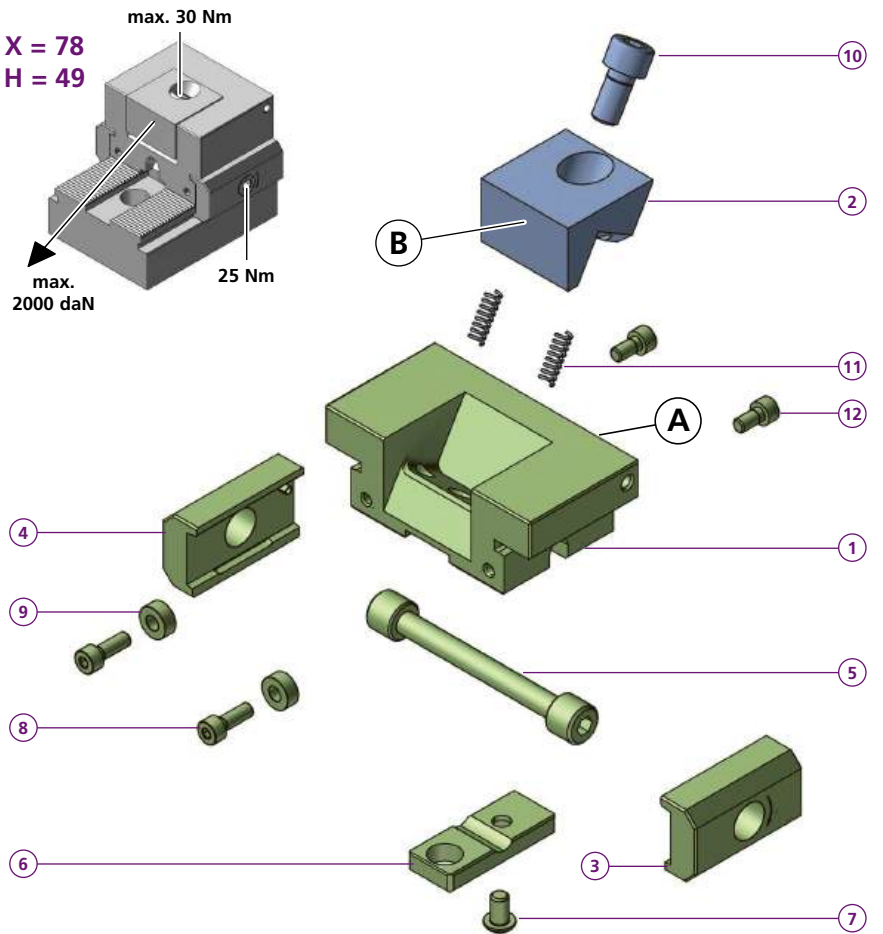

Bestellbeispiel / Ordering example: 1x PS1R94N34-80 & 1x B80

	B80	B80N	B81	B82	B82L33	B82HM	B83	B84	B89F	B89R
C	40	40	40	40	40	40	40	40	40	40
H	25	25	25	25	25	25	25	25	25	25
L	22	22	22	22,2	33	22,2	22	26,3	29	29
D	11	11	11	11	11	11	11	11	11	11
ø	15	15	15	15	15	15	15	15	15	15
i	56HRC	HV700 x0,2mm	56HRC	*	*	56HRC	HV700 x0,2mm	*	HV700 x0,2mm	HV700 x0,2mm
kg	~0,2	~0,2	~0,2	~0,2	~0,28	~0,2	~0,2	~0,2	~0,24	~0,24

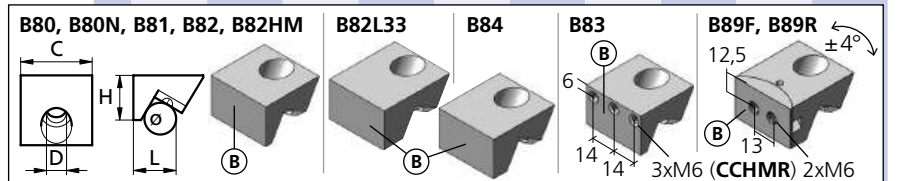

\* = weicher Stahl / soft steel

HM = Hartmetallbeschichtet / Carbide coated

Separat bestellen / Order separately

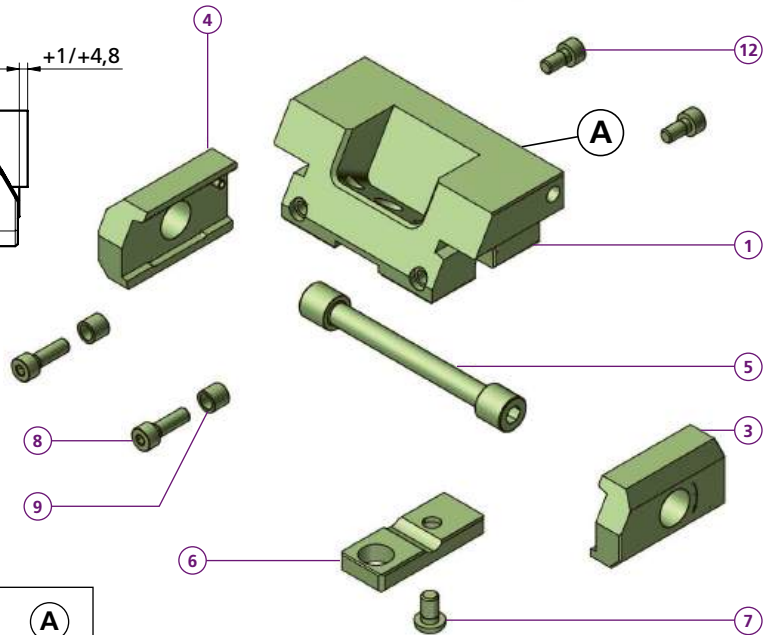
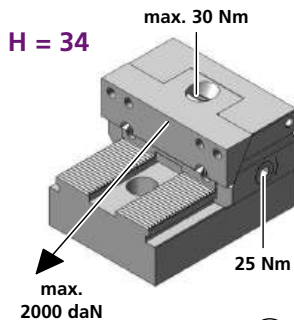
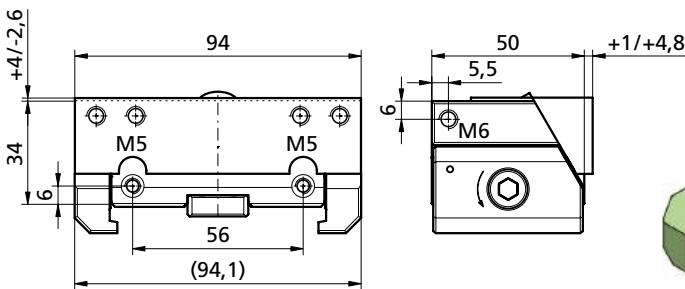
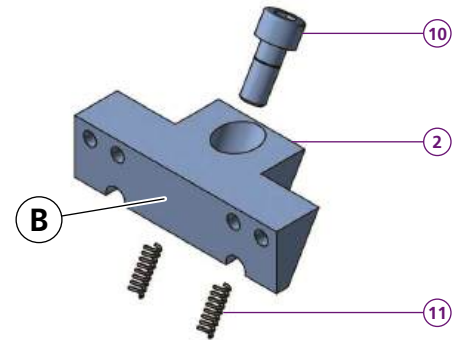
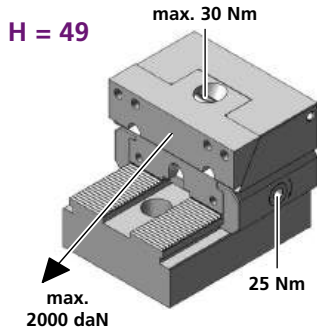
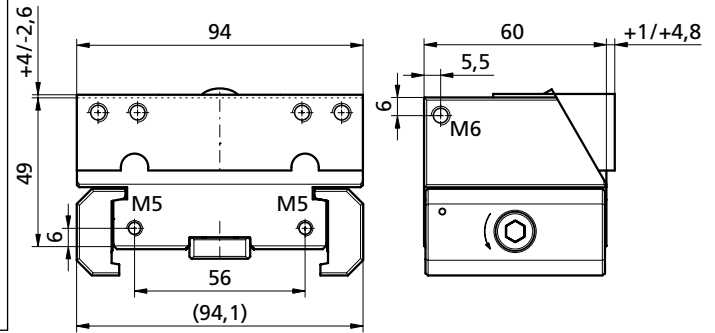
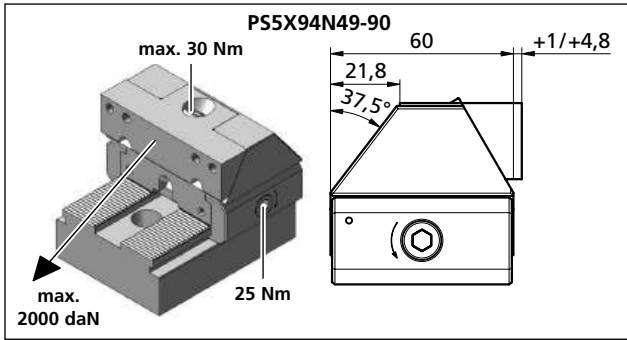

PS1F94N34-90		PS5X94N49-90	
1	1x TF140478	1	1x TF140482
2	1x _____	3	1x PCSP60R
3	1x PCSP50RF	4	1x PCSP60L
4	1x PCSP50LF	9	2x PCD005
5	1x PCS14	8	2x M5X14ISO4762
6	1x PCGU2049	kg	~1,8
7	1x M6X8ISO7380	<b>PS1F94N49-90</b>	
8	2x M5X16ISO4762	1	1x TF140480
9	2x PCD008	2	1x _____
10	1x M10X25ISO4762	<b>PS1R94N49-90</b>	
11	2x FED0618	1	1x TF140481
12	2x M5X10ISO4762	3	1x PCSP60R
H = 34		4	1x PCSP60L
kg ~1,0		8	2x M5X14ISO4762
		9	2x PCD005
		H = 49	
		kg ~2,0	

Bestellbeispiel / Ordering example:  
1x PS1F94N34-90 & 1x B91

	B90	B91	B92	B93	B94
C	94	94	94	94	94
H	25	25	25	25	25
L	23	23	23	23	40
D	11	11	11	11	11
e	15	15	15	15	15
i	HV700 x0,2mm	HV700 x0,2mm	*	HV700 x0,2mm	*
kg	~0,33	~0,33	~0,33	~0,33	~0,64

Separat bestellen / Order separately

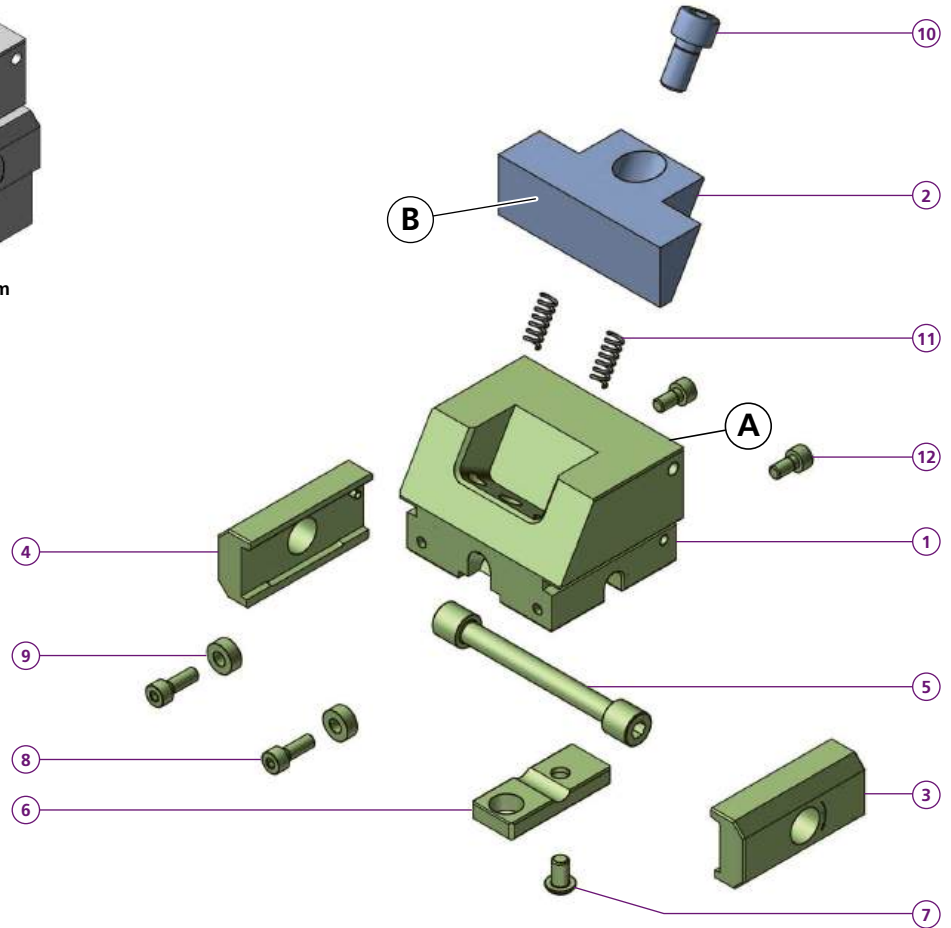
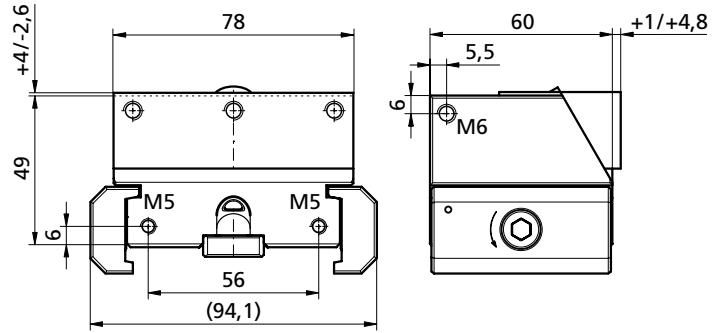
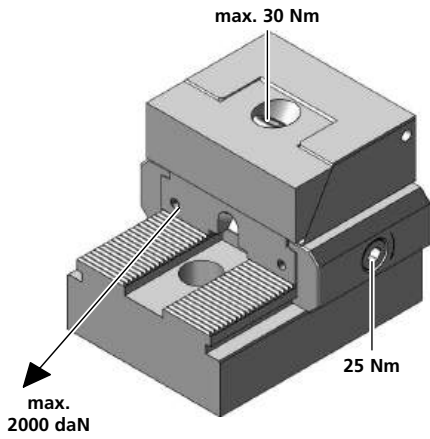

<b>PS1F78N49-90</b>	
1	1x TH160490
<b>PS1R78N49-90</b>	
1	1x TH160490
2	1x
3	1x PCSP60R
4	1x PCSP60L
5	1x PCS14
6	1x PCGU2049
7	1x M6X8ISO7380
8	2x M5X14ISO4762
9	2x PCD005
10	1x M10X25ISO4762
11	2x FED0618
12	2x M5X10ISO4762
kg	~1,8

Bestellbeispiel / Ordering example:  
1x PS1F78N49-90 & 1x B90F78

	B90F78	B90W78	B90R78
C	78	78	78
H	25	25	25
L	23	28	23
D	11	11	11
e	15	15	15
i	HV700	*	HV700
	x0,2mm		x0,2mm
kg	~0,3	~0,37	~0,3

**B90R78**

3xM6 (CCHMR)

**B90F78, B90W78**

\* = weicher Stahl / soft steel

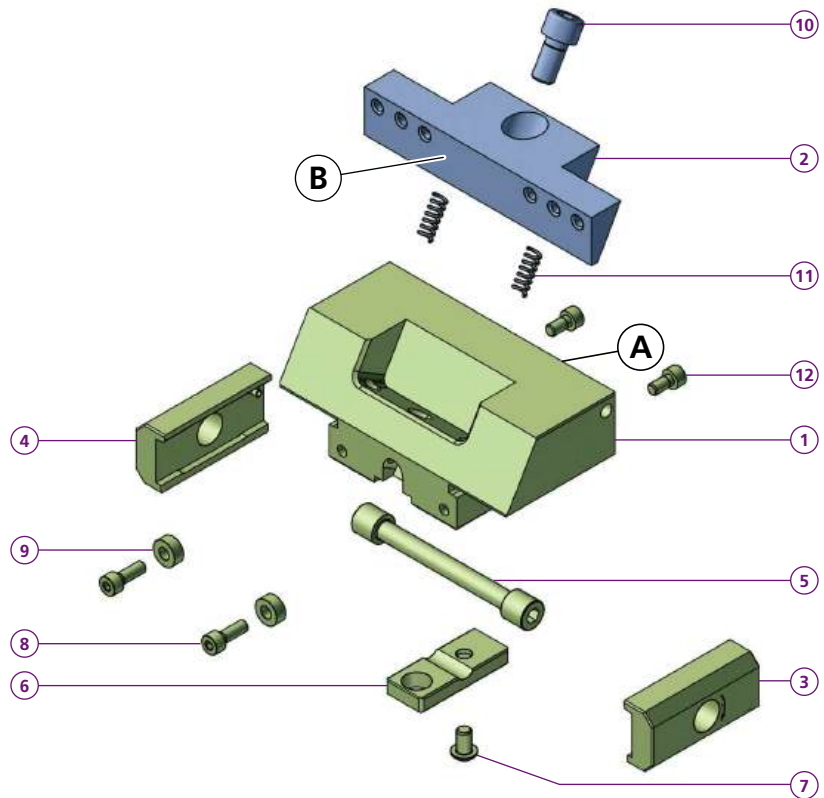
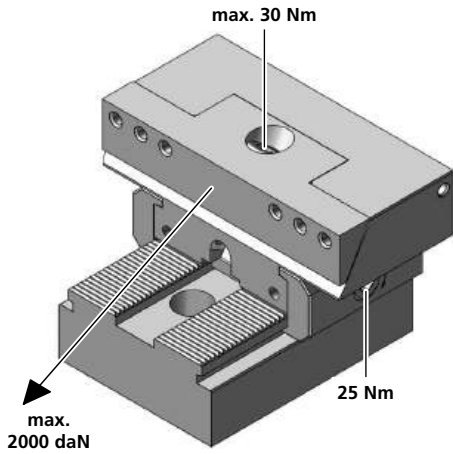
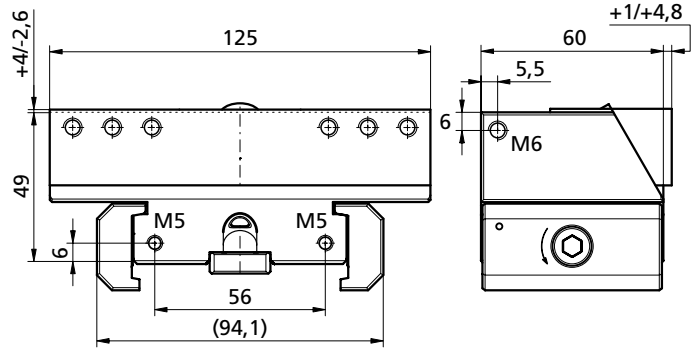
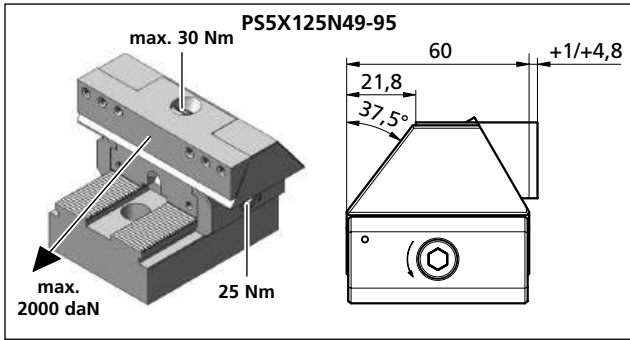

<b>37,5°</b>	<b>PS5X125N49-95</b>
1	1x TF140485
9	2x PCD005
8	2x M5X14ISO4762
kg	~2,0
	<b>PS1F125N49-95</b>
1	1x TF140483
	<b>PS1R125N49-95</b>
1	1x TF140484
2	1x _____
3	1x PCSP60R
4	1x PCSP60L
5	1x PCS14
6	1x PCGU2049
7	1x M6X8ISO7380
8	2x M5X14ISO4762
9	2x PCD005
10	1x M10X25ISO4762
11	2x FED0618
12	2x M5X10ISO4762
kg	~2,3

Bestellbeispiel / Ordering example: 1x PS5X125N49-95 & 1x B95

	B95	B96	B97	B98	B99
C	125	125	125	125	125
H	25	25	25	25	25
L	23	23	23	30	23
D	11	11	11	11	11
ø	15	15	15	15	15
i	HV700	HV700	*	*	HV700
	x0,2mm	x0,2mm			x0,2mm
kg	~0,46	~0,45	~0,46	~0,63	~0,45

  

B95, B96, B97, B99		B98	
6xM6 (CCHMR)		110	
		84	
		58	
		6	

Separat bestellen / Order separately

PS2G94N44-13

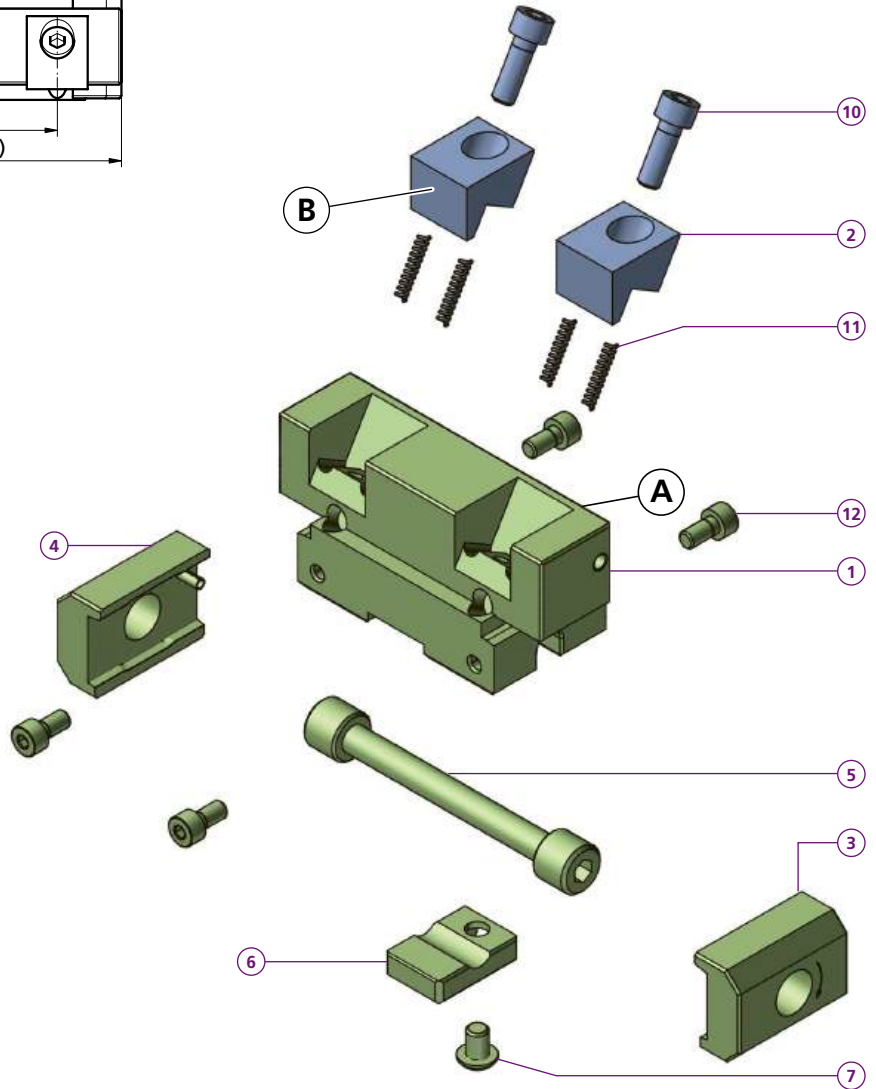
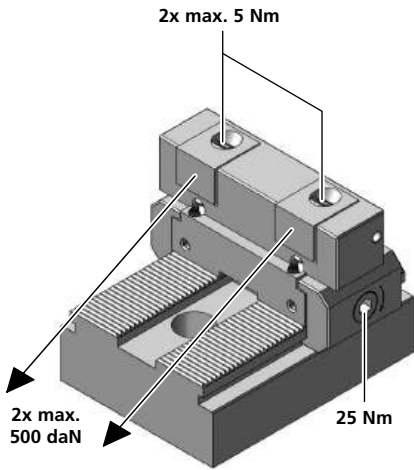
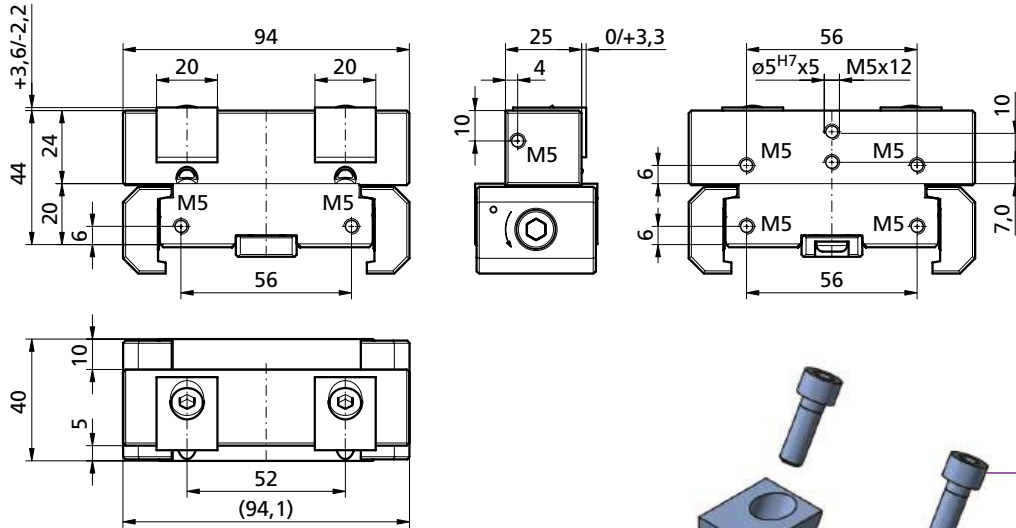

PS2G94N44-13	
1	1x TF140486
2	2x
3	1x PCSP40R
4	1x PCSP40L
5	1x PCS14
6	1x PCGU2030
7	1x M6X8ISO7380
10	2x M6X16ISO4762
11	4x FED0318
12	4x M5X10ISO4762
kg	~1,0

	B13	B14	B15	B16
C	20	20	20	20
H	16	16	16	16
L	13,8	13,8	13,8	19
D	6,5	6,5	6,5	6,5
ø	10	10	10	10
i	HV700	HV700	*	*
	x0,2mm	x0,2mm		
kg	~0,05	~0,05	~0,05	~0,06

Bestellbeispiel / Ordering example: 1x PS2G94N44-13 & 2x B14

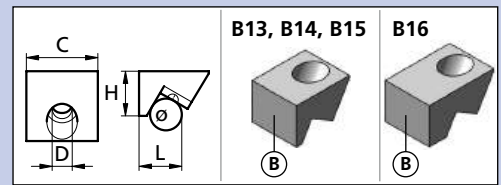

\* = weicher Stahl / soft steel

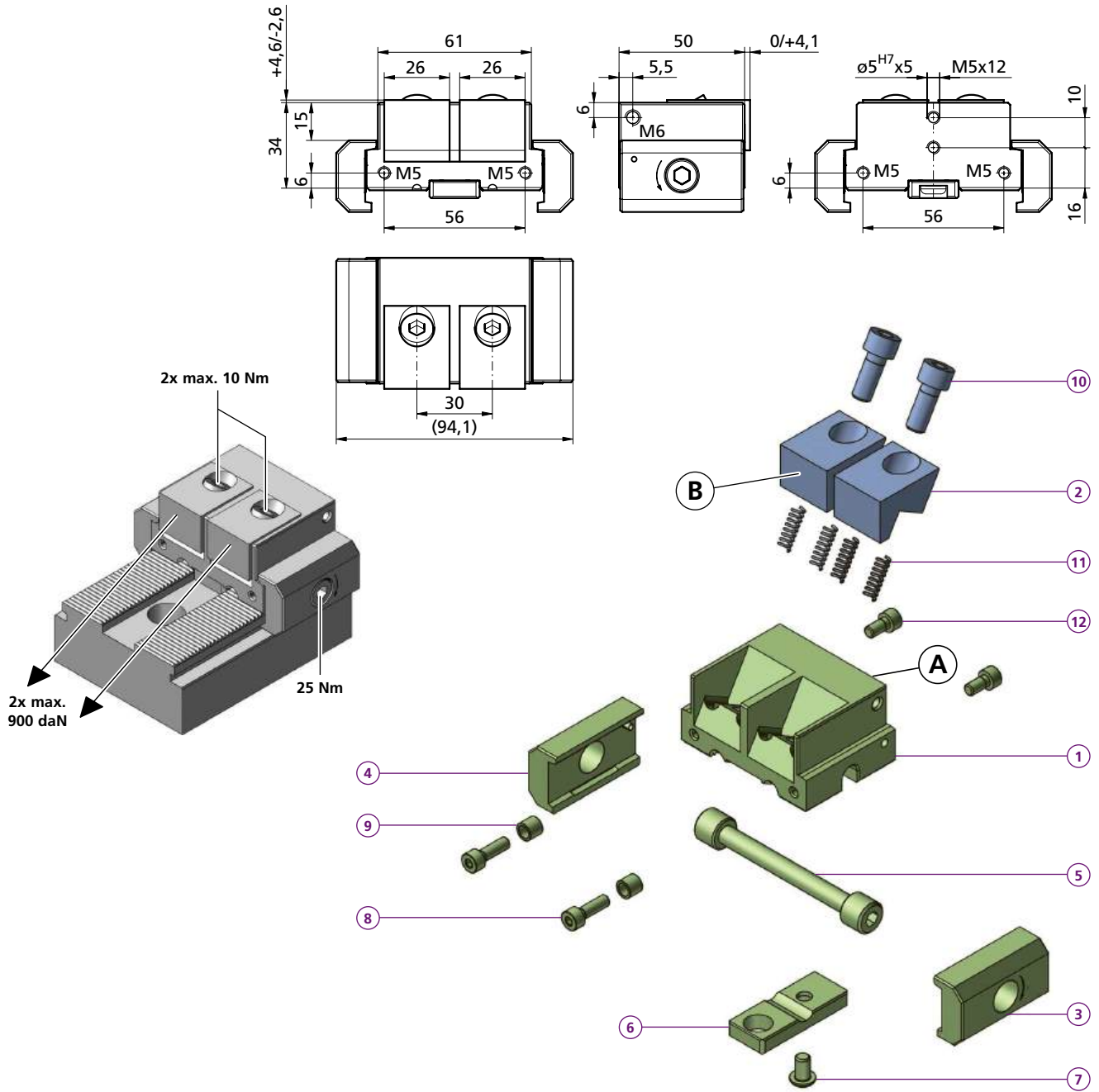

	<b>PS2F61N34-45</b>
①	1x TF140487
	<b>PS2R61N34-45</b>
①	1x TF140488
②	2x
③	1x PCSP50R
④	1x PCSP50L
⑤	1x PCS14
⑥	1x PCGU2049
⑦	1x M6X8ISO7380
⑧	2x M5X16ISO4762
⑨	2x PCD008
⑩	2x M8X20ISO4762
⑪	4x FED0618
⑫	2x M5X10ISO4762
kg	~1,0

**Bestellbeispiel / Ordering example: 1x PS2R61N34-45 & 2x B47HM**

	B45	B46	B47	B47HM
③	26	26	26	26
④	20	20	20	20
⑤	19	19	19,1	19,1
⑥	9	9	9	9
⑦	12	12	12	12
⑧	HV700	HV700	*	HM
	x0,2mm	x0,2mm		
kg	~0,1	~0,1	~0,1	~0,1

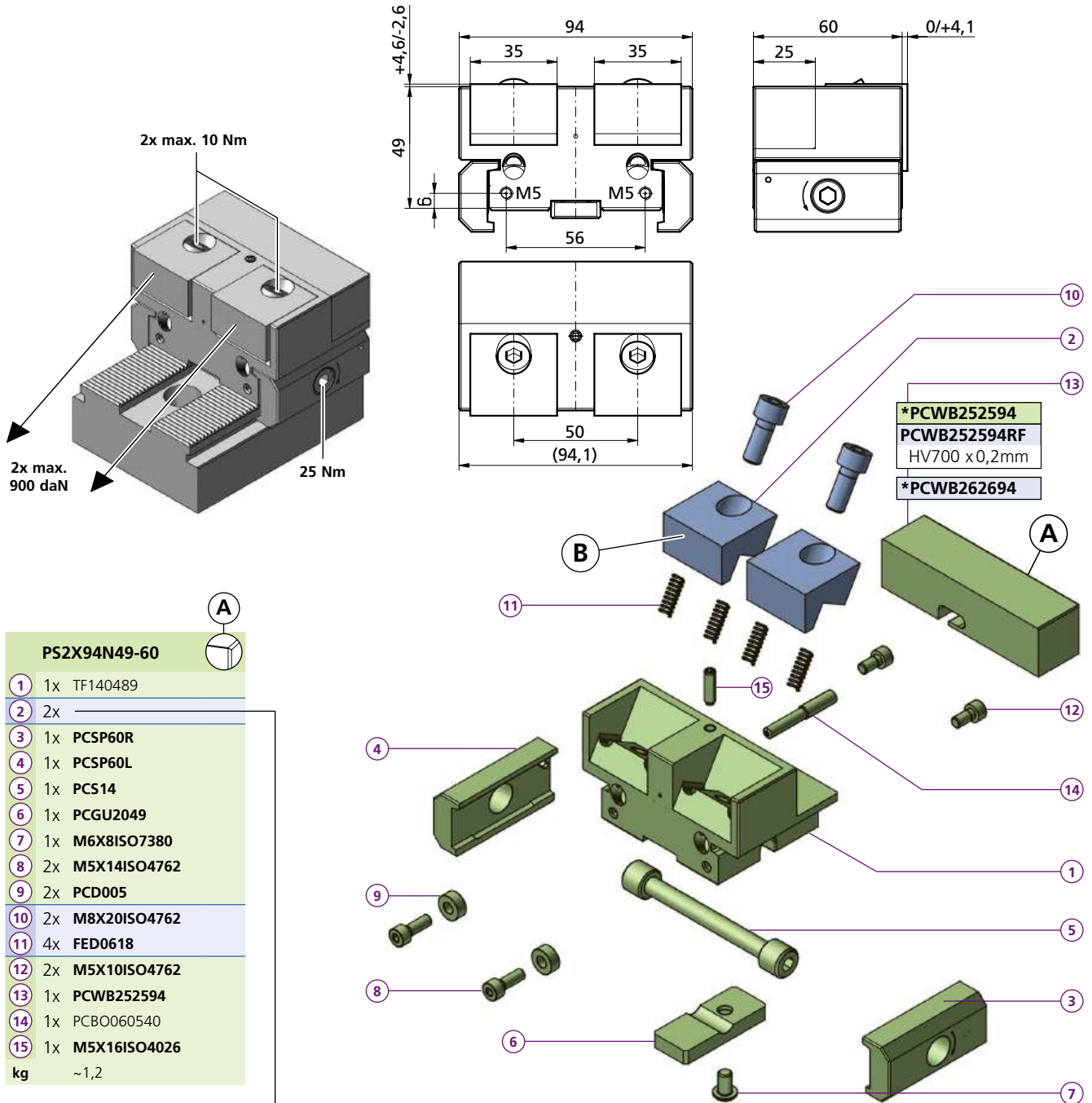

**PS2X94N49-60**

1	1x	TF140489
2	2x	
3	1x	PCSP60R
4	1x	PCSP60L
5	1x	PCS14
6	1x	PCGU2049
7	1x	M6X8ISO7380
8	2x	M5X14ISO4762
9	2x	PCD005
10	2x	M8X20ISO4762
11	4x	FED0618
12	2x	M5X10ISO4762
13	1x	PCWB252594
14	1x	PCBO060540
15	1x	M5X16ISO4026
kg		~1,2

**Bestellbeispiel / Ordering example:** 1x PS2X94N49-60 & 2x B58

	B58	B60	B61	B62	B62HM	B65	B66	B67	B68	B69	B77	B79F	B79R
<b>C</b>	35	35	35	35	35	35	35	35	35	35	35	35	35
<b>H</b>	20	20	20	20	20	20	20	20	20	25	20	20	20
<b>L</b>	26	19	19	19	19	19	19	24	26	22	22	25	25
<b>D</b>	9	9	9	9	9	9	9	9	9	9	9	9	9
<b>o</b>	12	12	12	12	12	12	12	12	12	12	12	12	12
<b>i</b>	ALU	56HRC	56HRC	*	HM	HV700 x0,2mm	HV700 x0,2mm	HV700 x0,2mm	*	*	56HRC	HV700 x0,2mm	HV700 x0,2mm
<b>kg</b>	~0,07	~0,12	~0,12	~0,12	~0,12	~0,12	~0,12	~0,14	~0,15	~0,15	~0,12	~0,18	~0,18

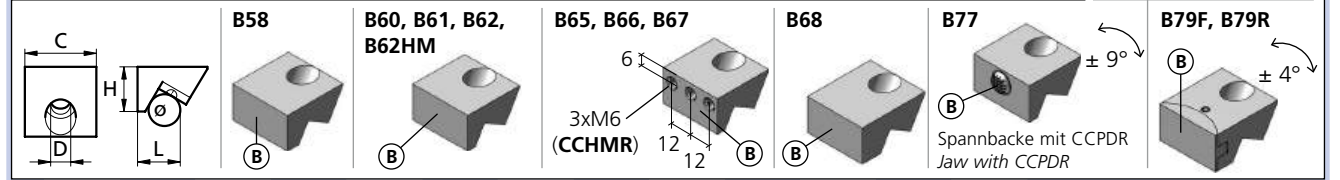
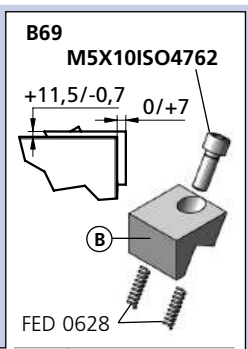

\* = weicher Stahl / soft steel      HM = Hartmetallbeschichtet / Carbide coated      ALU = ENAW-7022

Separat bestellen / Order separately

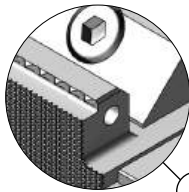
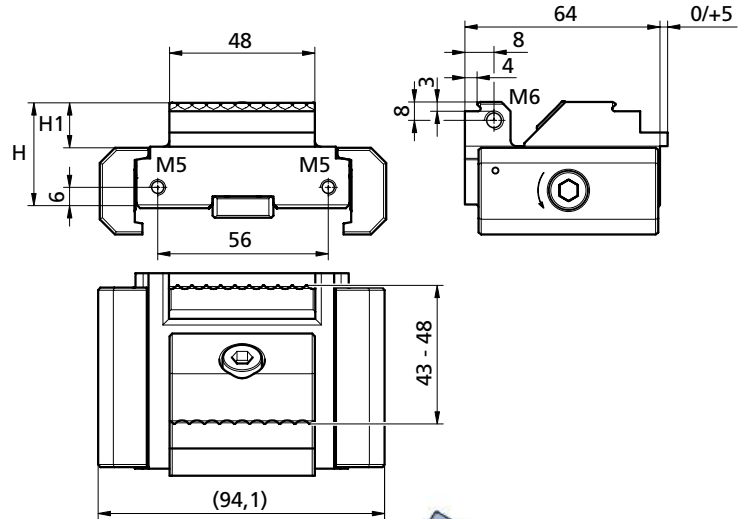
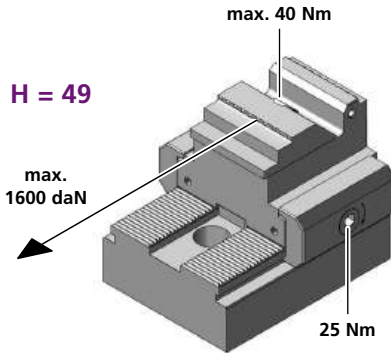
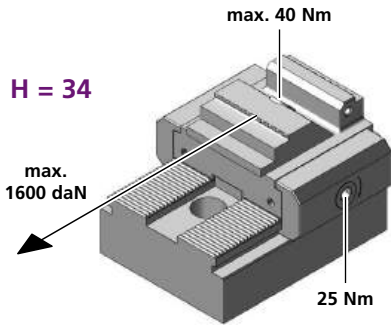

PS1P48L34-105

- 1 1x TW100098-01
  - 2 1x
  - 3 1x PCSP60R
  - 4 1x PCSP60L
  - 5 1x PCS14
  - 6 1x PCGU2059
  - 7 1x M6X8ISO7380
  - 8 2x M5X14ISO4762
  - 9 2x PCD005
  - 10 1x M8X28ISO4762
  - 11 1x PCUSR16
  - 12 2x M5X10ISO4762
  - 13 1x PCKMR45M8
  - 14 2x D=6 DIN 5401
- H = 34  
H1 = 15  
kg ~1,0

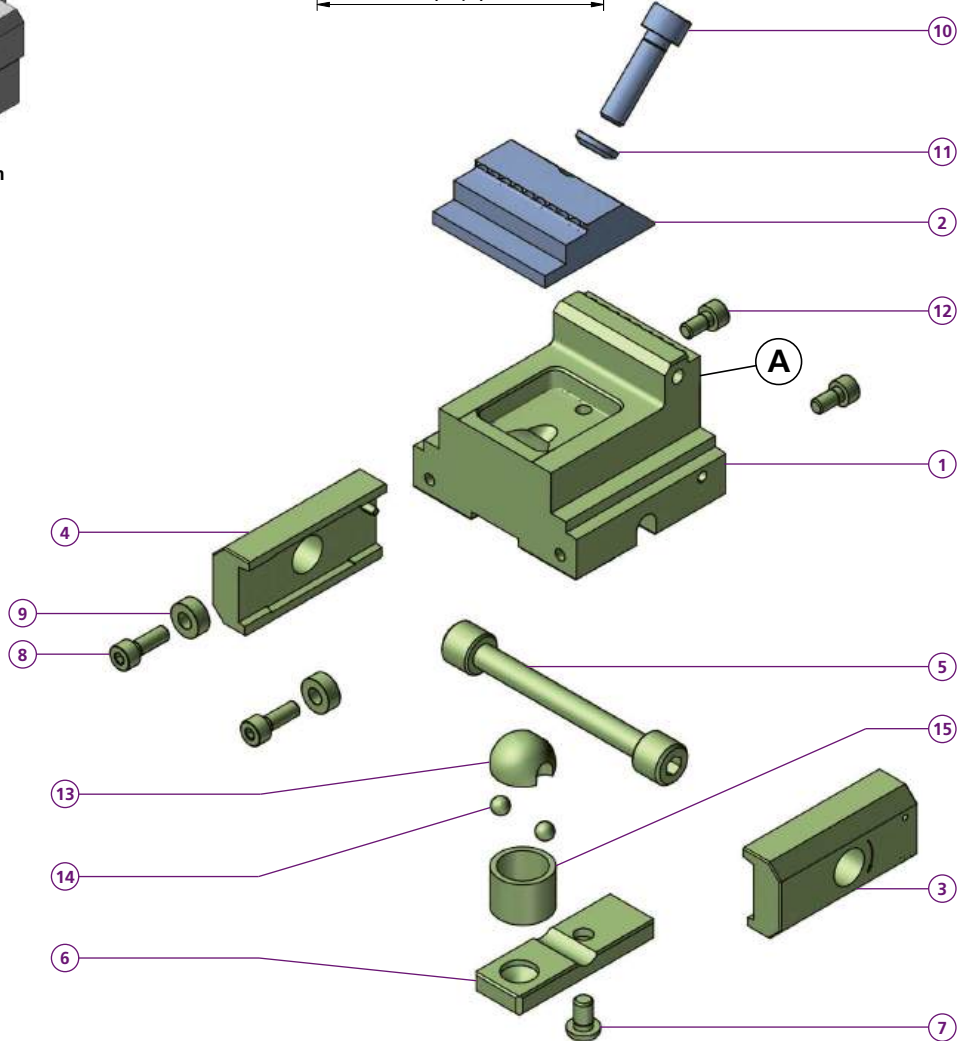

p. 84, 85

PS1PF48L34-105

- 1 1x TK140780
- H = 49  
H1 = 30  
kg ~1,0

PS1P48L49-105

- 1 1x TK120011
  - 15 1x PCD20L15
- H = 49  
H1 = 30  
kg ~1,4

PS1PF48L49-105

- 1 1x TK140781
  - 15 1x PCD20L15
- H = 49  
H1 = 30  
kg ~1,4

Bestellbeispiel / Ordering example:  
1x PS1P48L34-105 & 1x B115

Drehmoment Torque		Spannkraft Workholding force		
Nm	(lb-ft)	~daN	~(lb)	~t
10	7,4	= 400	880	0,4
20	14,8	= 800	1'760	0,8
30	22,2	= 1'200	2'650	1,2
40	29,6	= 1'600	3'530	1,6

PS1P94L34-105

PS1P694L34-105

PS1P94L49-105

PS1PF94L49-105

PS1PF94L34-105

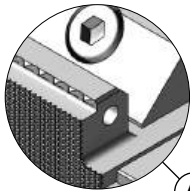
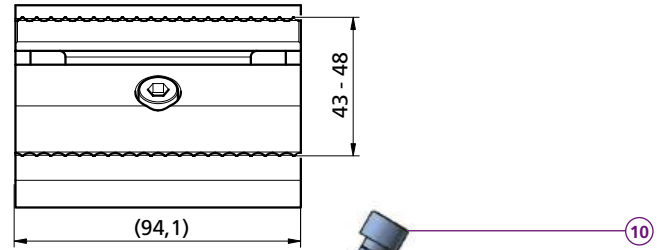
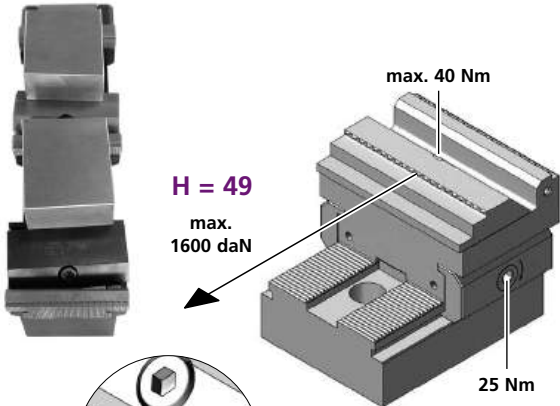
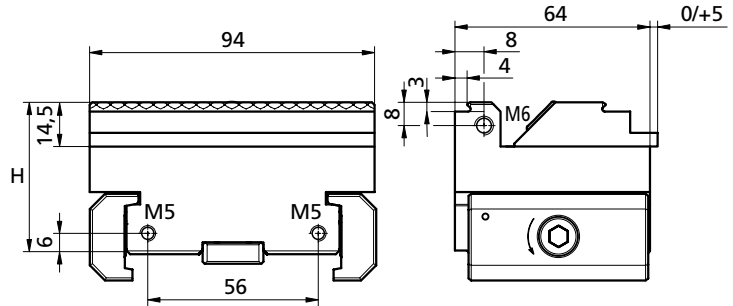
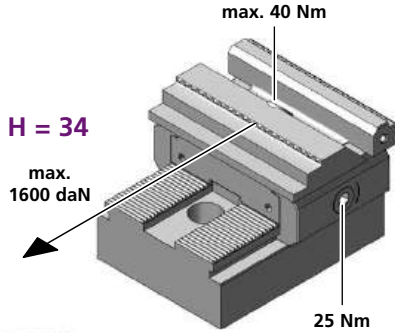

PS1P94L34-105

- 1 1x TW100100-01
- 2 1x
- 3 1x PCSP60R
- 4 1x PCSP60L
- 5 1x PCS14
- 6 1x PCGU2059
- 7 1x M6X8ISO7380
- 8 2x M5X14ISO4762
- 9 2x PCD005
- 10 1x M8X28ISO4762
- 11 1x PCUSR16
- 12 2x M5X10ISO4762
- 13 1x PCKMR45M8
- 14 2x D=6 DIN 5401
- H = 34
- kg ~1,1

p. 84, 85

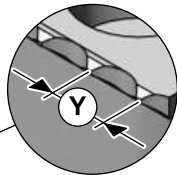

PS1P694L34-105

- 1 1x TW100100-02
- Y 6,0 mm
- kg ~1,1

PS1PF94L34-105

- 1 1x TK140782
- H = 49
- kg ~1,1

PS1P94L49-105

- 1 1x TK120857
- 15 1x PCD20L15
- H = 49
- kg ~1,8

PS1PF94L49-105

- 1 1x TK140783
- 15 1x PCD20L15
- H = 49
- kg ~1,8

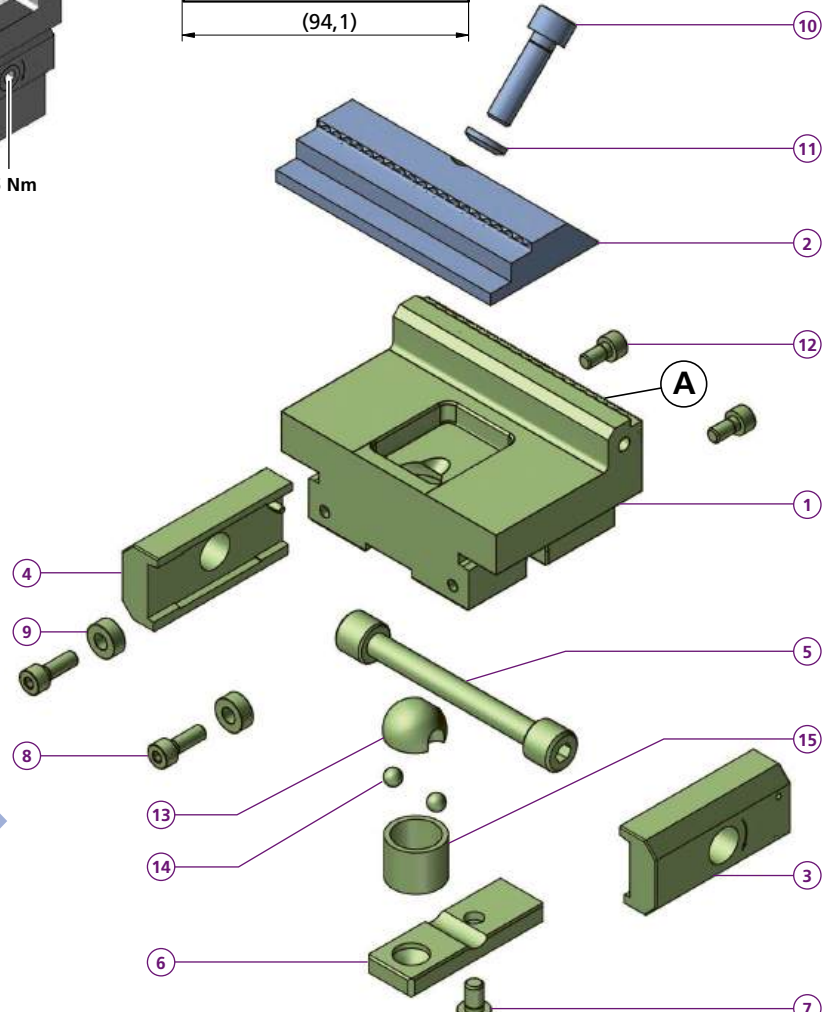

Bestellbeispiel / Ordering example:  
1x PS1P94L34-105 & 1x B120

Drehmoment Torque		Spannkraft Workholding force		
Nm	(lb-ft)	~daN	~(lb)	~t
10	7,4	= 400	880	0,4
20	14,8	= 800	1'760	0,8
30	22,2	= 1'200	2'650	1,2
40	29,6	= 1'600	3'530	1,6

PS1PV48L34-105  
PS1R/F48L34-105

Linear  
powerCLAMP

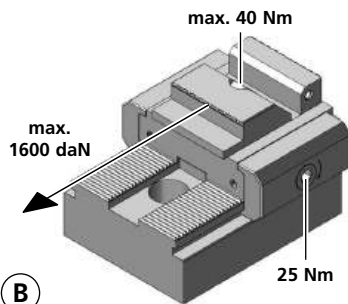
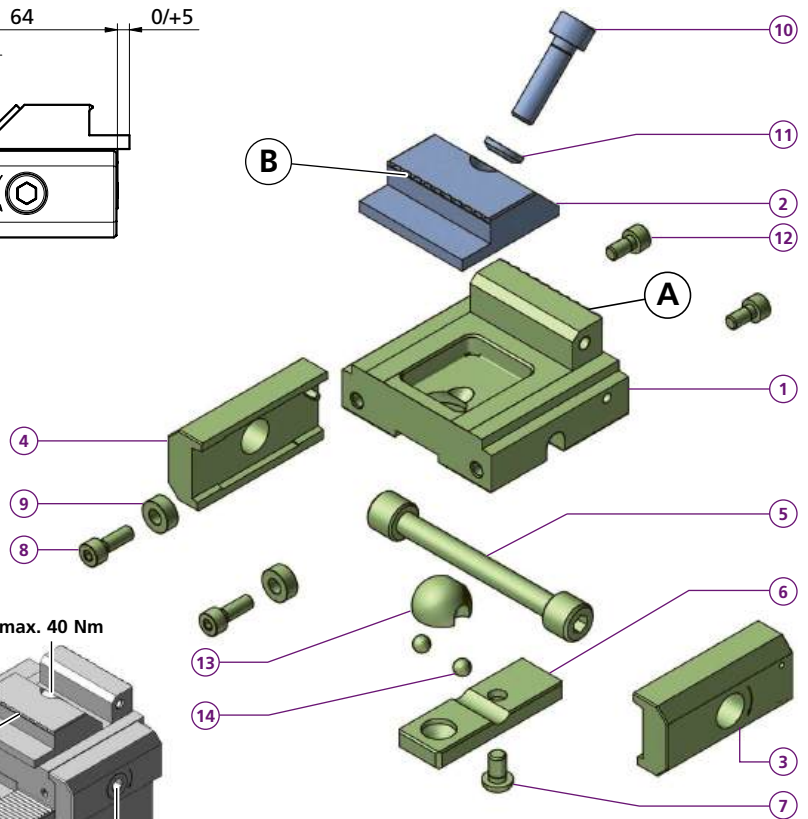
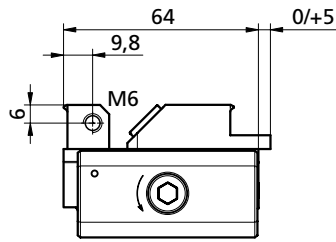
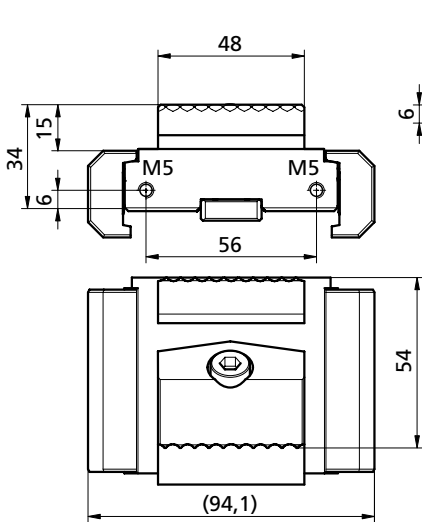

**PS1PV48L34-105**

- 1 1x TK140762
- 2 1x
- 3 1x PCSP60R
- 4 1x PCSP60L
- 5 1x PCS14
- 6 1x PCGU2059
- 7 1x M6X8ISO7380
- 8 2x M5X14ISO4762
- 9 2x PCD005
- 10 1x M8X28ISO4762
- 11 1x PCUSR16
- 12 2x M5X10ISO4762
- 13 1x PCKMR45M8
- 14 2x D=6 DIN 5401

kg ~1,0

**B123P**

- C 48
- H 14,5
- L 47
- i 56HRC
- kg ~0,21

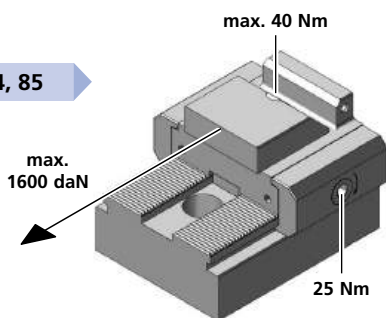
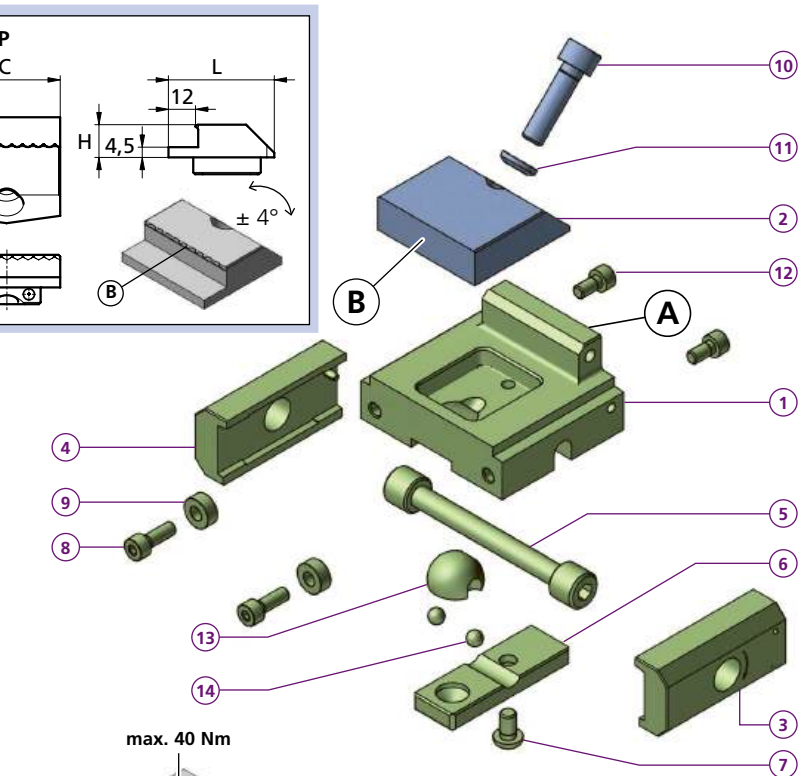

**PS1R48L34-105**

- 1 1x TF140573

**PS1F48L34-105**

- 1 1x TF140572
- 2 1x
- 3 1x PCSP60R
- 4 1x PCSP60L
- 5 1x PCS14
- 6 1x PCGU2059
- 7 1x M6X8ISO7380
- 8 2x M5X14ISO4762
- 9 2x PCD005
- 10 1x M8X30ISO4762
- 11 1x PCUSR14
- 12 2x M5X10ISO4762
- 13 1x PCKMR45M8
- 14 2x D=6 DIN 5401

kg ~1,0

p. 84, 85

Bestellbeispiel / Ordering example:  
1x PS1R48L34-105 & 1x B123P

Drehmoment Torque		Spannkraft Workholding force		
Nm	(lb-ft)	~daN	~(lb)	~t
10	7,4	= 400	880	0,4
20	14,8	= 800	1'760	0,8
30	22,2	= 1'200	2'650	1,2
40	29,6	= 1'600	3'530	1,6

Separat bestellen / Order separately

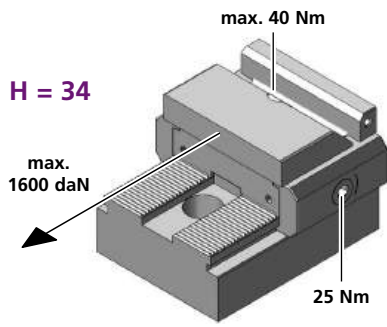

H = 34

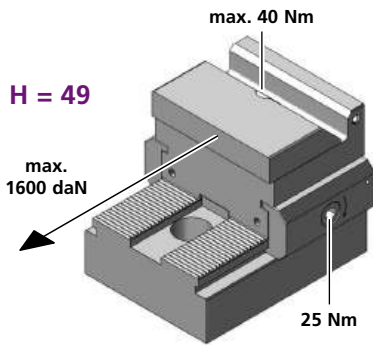

H = 49

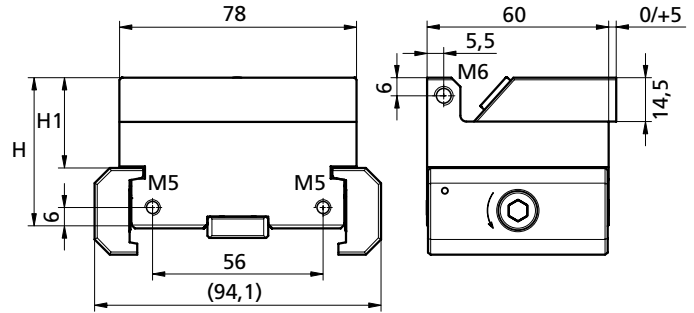

- PS1R78L34-105**
- 1 1x TF140575
- PS1F78L34-105**
- 1 1x TF140574
  - 2 1x
  - 3 1x PCSP60R
  - 4 1x PCSP60L
  - 5 1x PCS14
  - 6 1x PCGU2059
  - 7 1x M6X8ISO7380
  - 8 2x M5X14ISO4762
  - 9 2x PCD005
  - 10 1x M8X30ISO4762
  - 11 1x PCUSR14
  - 12 2x M5X10ISO4762
  - 13 1x PCKMR45M8
  - 14 2x D=6 DIN 5401
- H = 34  
H1 = 15  
kg ~1,0

p. 84, 85

- PS1R78L49-105**
- 1 1x TK110399
  - 15 2x PCD20L15
- PS1F78L49-105**
- 1 1x TK110400
  - 15 2x PCD20L15
- H = 49  
H1 = 30  
kg ~1,5

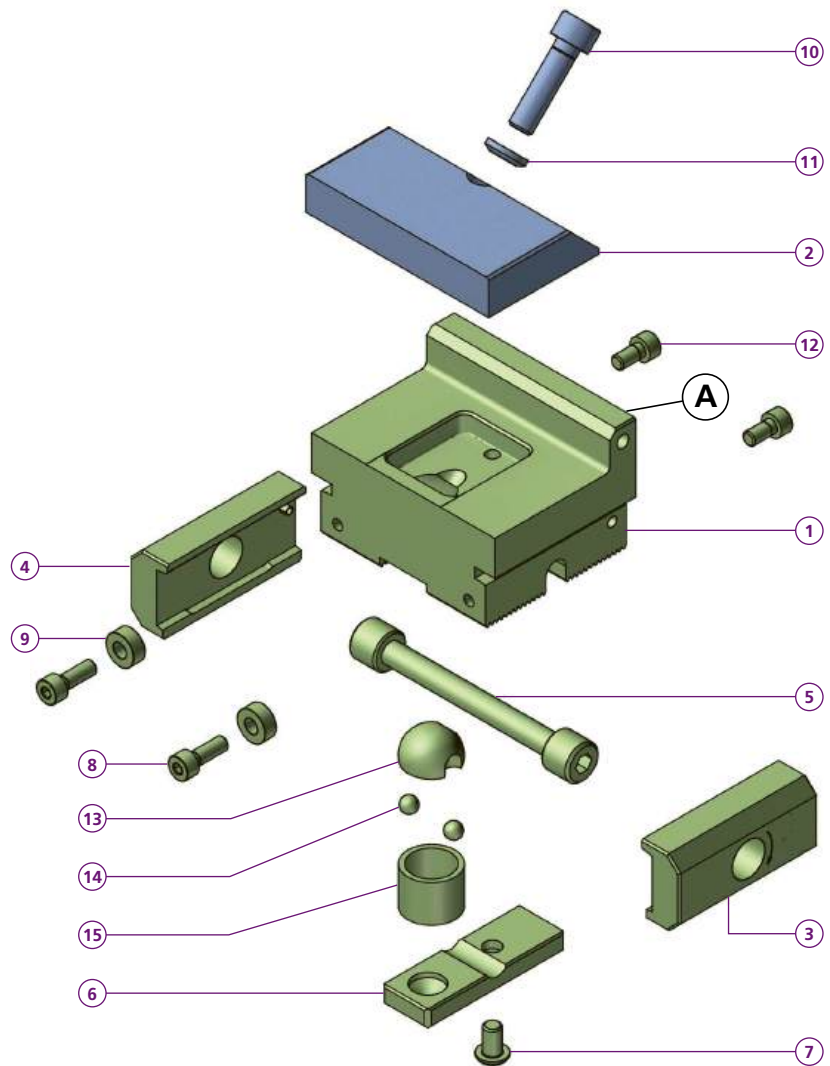

Bestellbeispiel / Ordering example:  
1x PS1R48L34-105 & 1x B105

Drehmoment Torque	Spannkraft Workholding force		
	Nm (lb-ft)	~daN	~(lb) ~t
10	7,4 =	400	880 0,4
20	14,8 =	800	1'760 0,8
30	22,2 =	1'200	2'650 1,2
40	29,6 =	1'600	3'530 1,6

PS1PV94L34-105  
PS1PV94L49-105

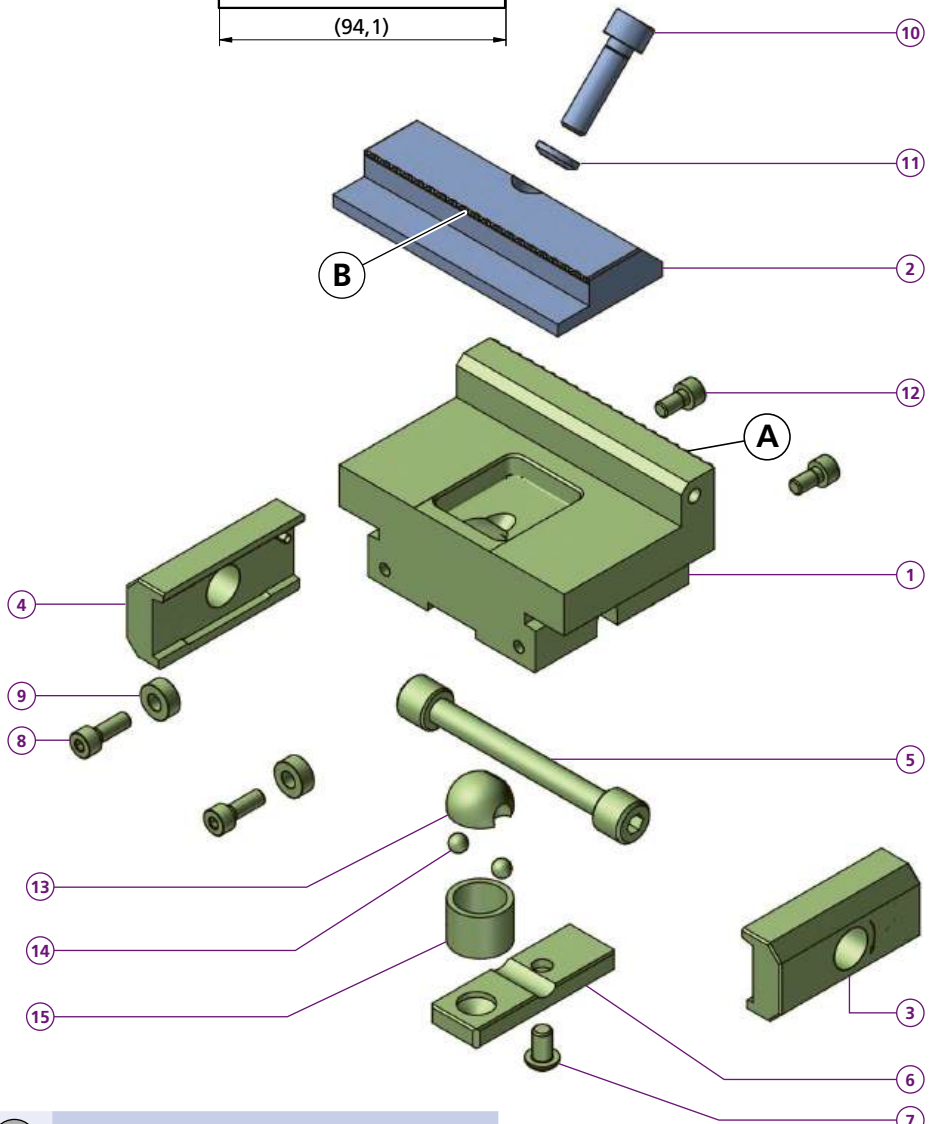
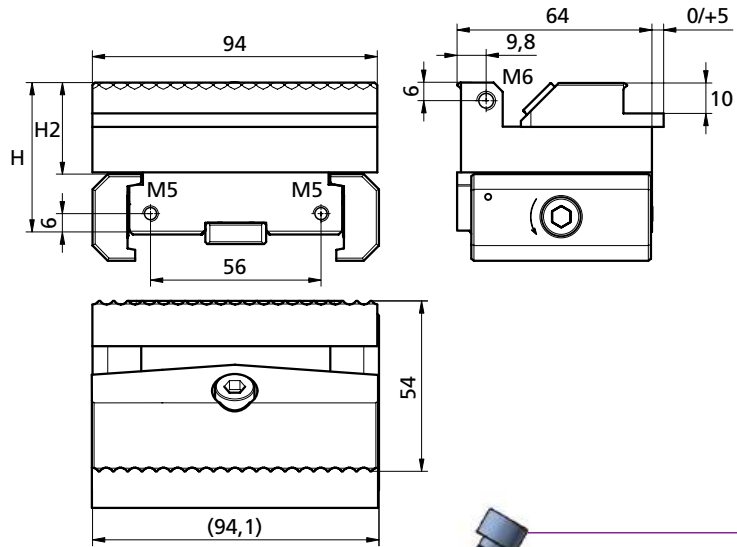
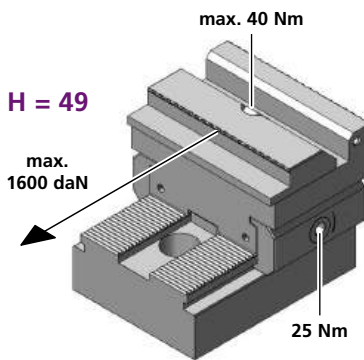
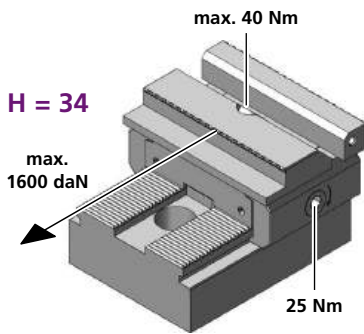

PS1PV94L34-105	
1	1x TK120230
2	1x
3	1x PCSP60R
4	1x PCSP60L
5	1x PCS14
6	1x PCGU2059
7	1x M6X8ISO7380
8	2x M5X14ISO4762
9	2x PCD005
10	1x M8X28ISO4762
11	1x PCUSR16
12	2x M5X10ISO4762
13	1x PCKMR45M8
14	2x D=6 DIN 5401
H	= 34
H1	= 15
kg	~1,1

PS1PV94L49-105	
1	1x TK110250
15	1x PCD20L15
H	= 49
H1	= 30
kg	~1,8

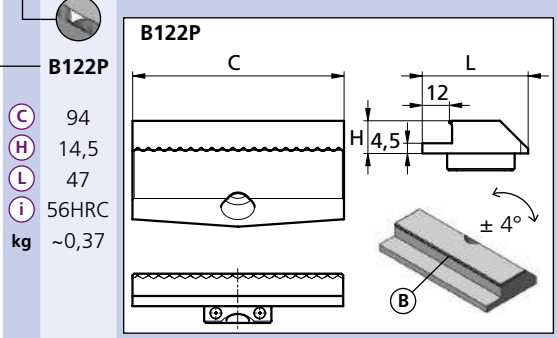

Bestellbeispiel / Ordering example:  
1x PS1PV94L49-105 & 1x B122P

Drehmoment Torque		Spannkraft Workholding force		
Nm	(lb-ft)	~daN	~(lb)	~t
10	7,4	= 400	880	0,4
20	14,8	= 800	1'760	0,8
30	22,2	= 1'200	2'650	1,2
40	29,6	= 1'600	3'530	1,6

Separat bestellen / Order separately

PS1R/F48L49-105  
PS5X48L49-105

Linear 5axes  
powerCLAMP

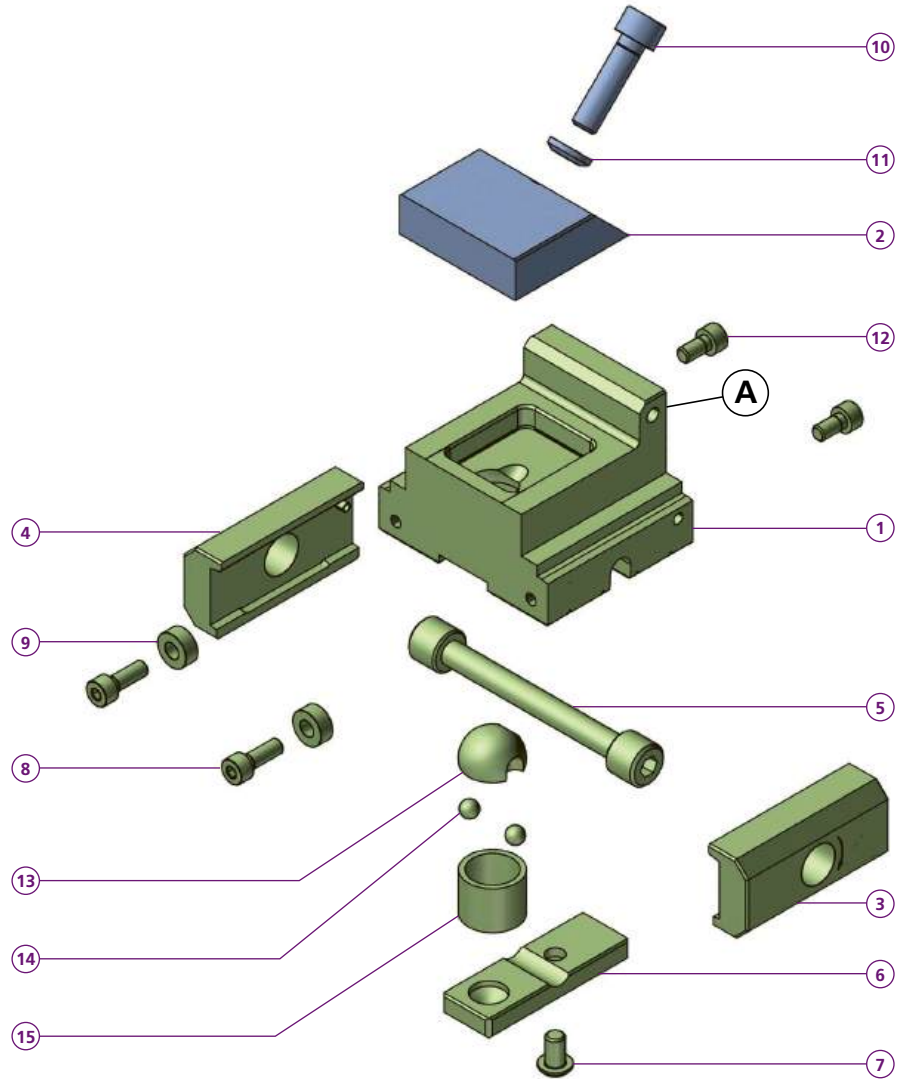
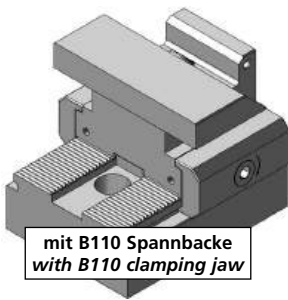
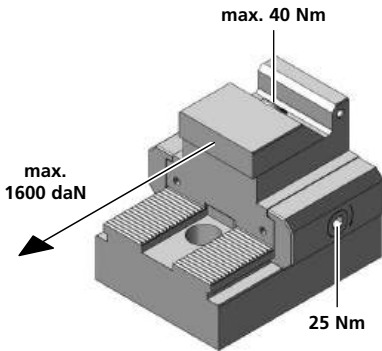
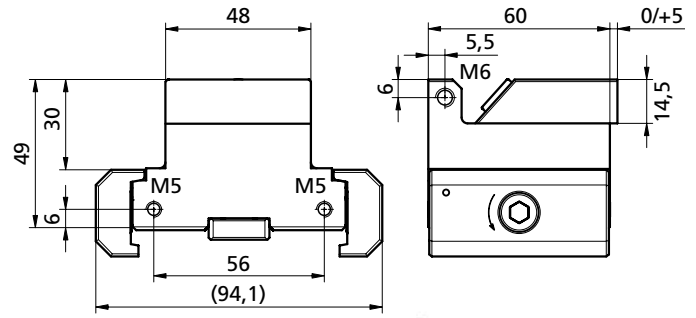
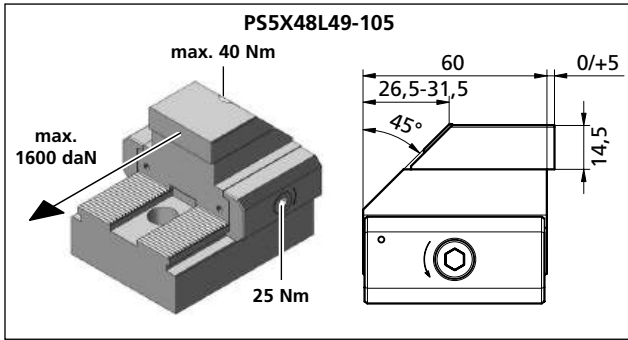

45°	<b>PS5X48L49-105</b>
1	1x TF190651
9	2x PCD005
8	2x M5X14ISO4762
kg	~1,2
	<b>PS1F48L49-105</b>
1	1x TF140673
	<b>PS1R48L49-105</b>
1	1x TF140672
2	1x —
3	1x PCSP60R
4	1x PCSP60L
5	1x PCS14
6	1x PCGU2059
7	1x M6X8ISO7380
8	2x M5X14ISO4762
9	2x PCD005
10	1x M8X30ISO4762
11	1x PCUSR14
12	2x M5X10ISO4762
13	1x PCKMR45M8
14	2x D=6 DIN 5401
15	1x PCD20L15
kg	~1,3

p. 84, 85

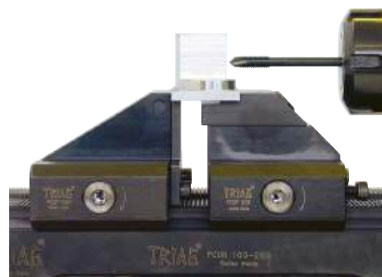

Bestellbeispiel / Ordering example:  
1x PS1F48L49-105 & 1x B105

Drehmoment Torque	Spannkraft Workholding force		
	Nm (lb-ft)	~daN	~(lb) ~t
10	7,4 =	400	880 0,4
20	14,8 =	800	1'760 0,8
30	22,2 =	1'200	2'650 1,2
40	29,6 =	1'600	3'530 1,6

Separat bestellen / Order separately

PS5X48L34-105

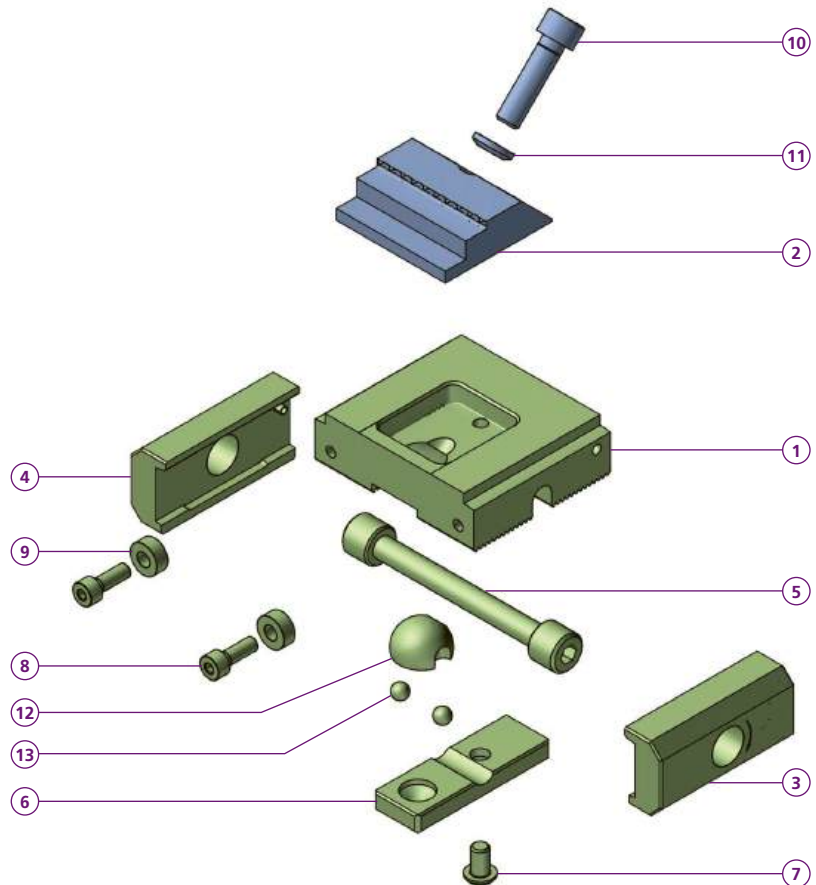
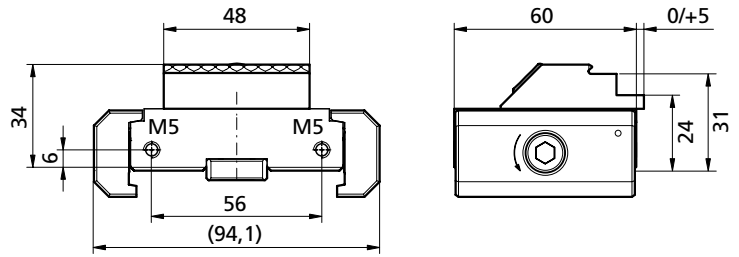
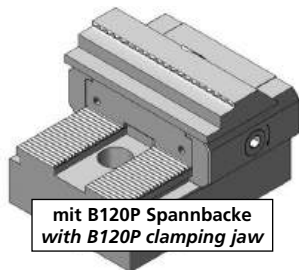
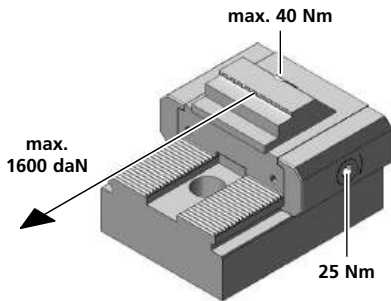

**PS5X48L34-105**

- ① 1x T00365
- ② 1x —————
- ③ 1x PCSP60R
- ④ 1x PCSP60L
- ⑤ 1x PCS14
- ⑥ 1x PCGU2059
- ⑦ 1x M6X8ISO7380
- ⑧ 2x M5X14ISO4762
- ⑨ 2x PCD005
- ⑩ 1x M8X28ISO4762
- ⑪ 1x PCUSR16
- ⑫ 1x PCKMR45M8
- ⑬ 2x D=6 DIN 5401

p. 84, 85

kg ~0,9

Bestellbeispiel / Ordering example:  
1x PS5X48L34-105 & 1x B105

Drehmoment Torque		Spannkraft Workholding force		
Nm	(lb-ft)	~daN	~(lb)	~t
10	7,4	= 400	880	0,4
20	14,8	= 800	1'760	0,8
30	22,2	= 1'200	2'650	1,2
40	29,6	= 1'600	3'530	1,6

Separat bestellen / Order separately

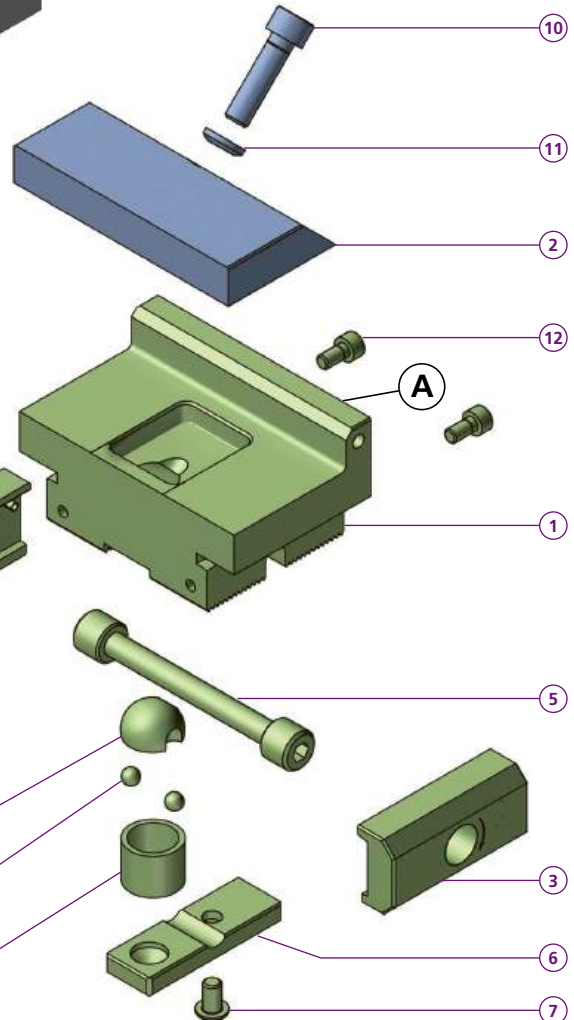
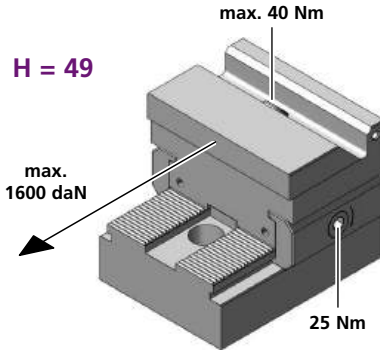
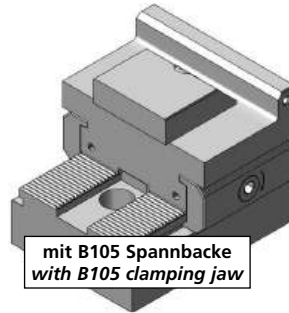
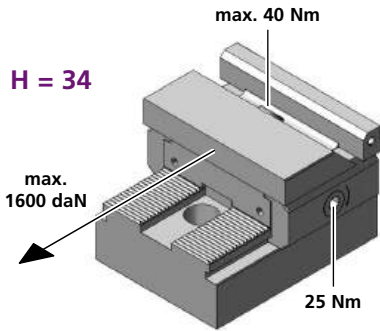
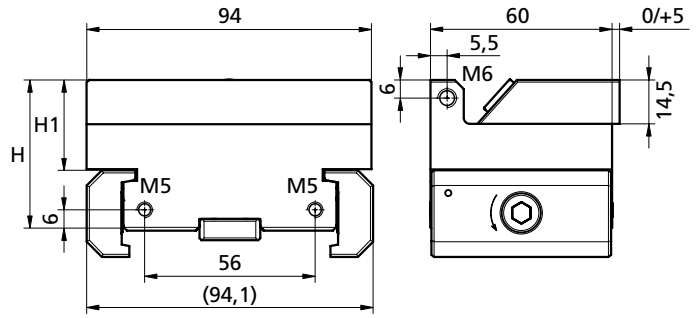
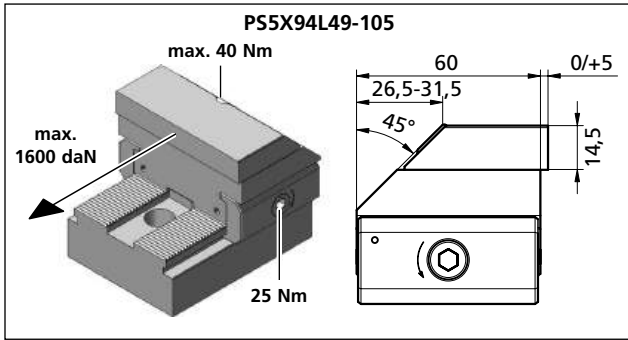

	<b>PS5X94L49-105</b>
1	1x TW100186
15	2x PCD20L15
9	2x PCD005
8	2x M5X14ISO4762
kg	~1,5
	<b>PS1F94L34-105</b>
1	1x TH130785
	<b>PS1R94L34-105</b>
1	1x TH130786
2	1x <b>p. 84, 85</b>
3	1x PCSP60R
4	1x PCSP60L
5	1x PCS14
6	1x PCGU2059
7	1x M6X8ISO7380
8	2x M5X14ISO4762
9	2x PCD005
10	1x M8X30ISO4762
11	1x PCUSR14
12	2x M5X10ISO4762
13	1x PCKMR45M8
14	2x D=6 DIN 5401
H	= 34
H1	= 15
kg	~1,0

	<b>PS1F94L49-105</b>
1	1x TF140674
15	2x PCD20L15
	<b>PS1R94L49-105</b>
1	1x TF140675
15	2x PCD20L15
H	= 49
H1	= 30
kg	~1,7

Bestellbeispiel / Ordering example:  
1x PS1R94L49-105 & 1x B105

Drehmoment Torque	Spannkraft Workholding force		
	Nm (lb-ft)	~daN	~(lb) ~t
10	7,4 = 400	880	0,4
20	14,8 = 800	1'760	0,8
30	22,2 = 1'200	2'650	1,2
40	29,6 = 1'600	3'530	1,6

Separat bestellen / Order separately

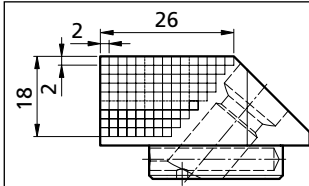

Zum Erstellen Ihrer individuellen Formbacke: *If a dedicated jaw is being machined:*  
 Schnittzeichnung zum Ermitteln der maximalen Bearbeitungsprofiltiefe  
*Sectional drawing to determine the maximum machining depth*

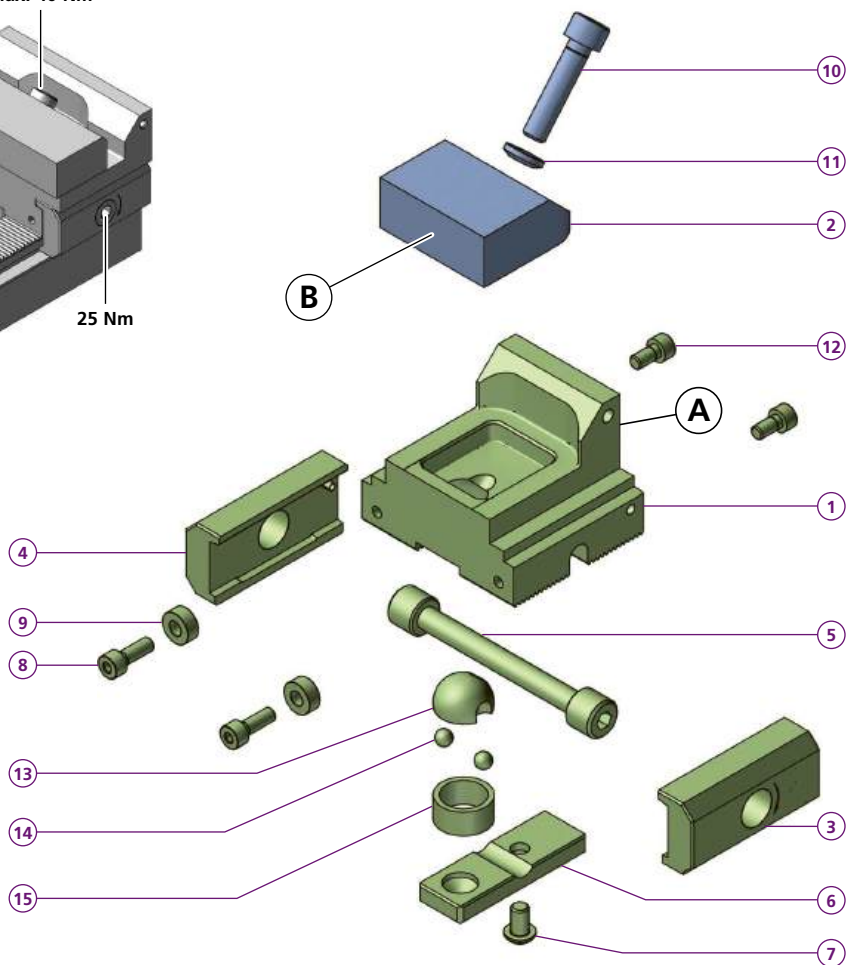
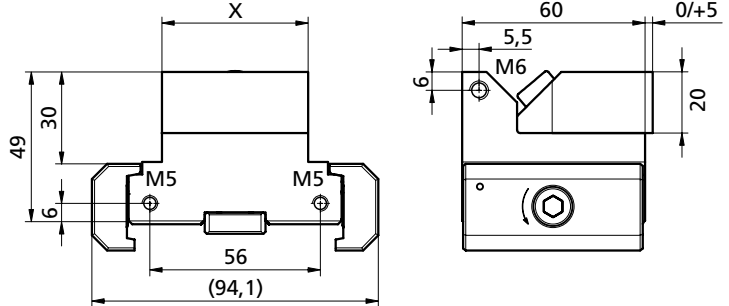
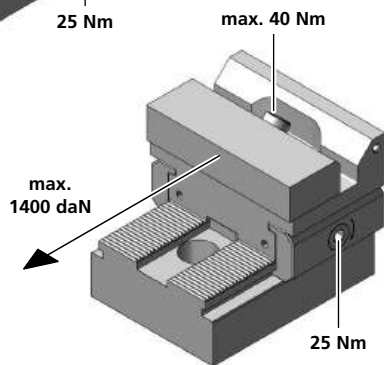
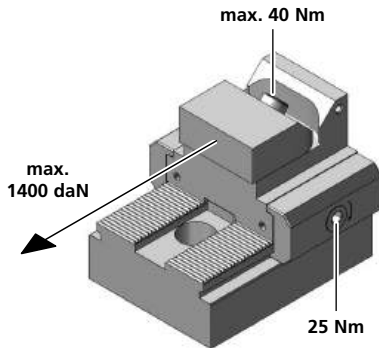

<b>PS1R48L49-105H20</b>	
1	1x TW100161-01
2	1x
3	1x PCSP60R
4	1x PCSP60L
5	1x PCS14
6	1x PCGU2059
7	1x M6X8ISO7380
8	2x M5X14ISO4762
9	2x PCD005
10	1x M8X35ISO4762
11	1x PCUSR14
12	2x M5X10ISO4762
13	1x PCKMR45M8
14	2x D=6 DIN 5401
15	1x PCD20L095
X	= 48
kg	~1,2
<b>PS1R94L49-105H20</b>	
1	1x TW100161-07
X	= 94
kg	~1,5

Bestellbeispiel / Ordering example: 1x PS1R48L49-105H20 & 1x B107H20

	B105H20	B106H20	B107H20	B110H20	B111H20	B112H20
C	48	48	48	94	94	94
H	20	20	20	20	20	20
L	47	47	47	47	47	47
i	HV700 x0,2mm	HV700 x0,2mm	*	HV700 x0,2mm	HV700 x0,2mm	*
kg	~0,38	~0,38	~0,38	~0,57	~0,56	~0,56

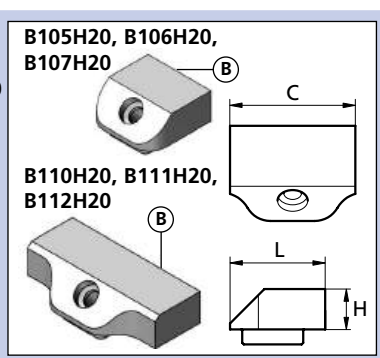

Separat bestellen / Order separately

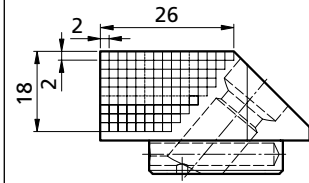

Zum Erstellen Ihrer individuellen Formbacke: *If a dedicated jaw is being machined:*  
 Schnittzeichnung zum Ermitteln der maximalen Bearbeitungsprofiltiefe  
*Sectional drawing to determine the maximum machining depth*

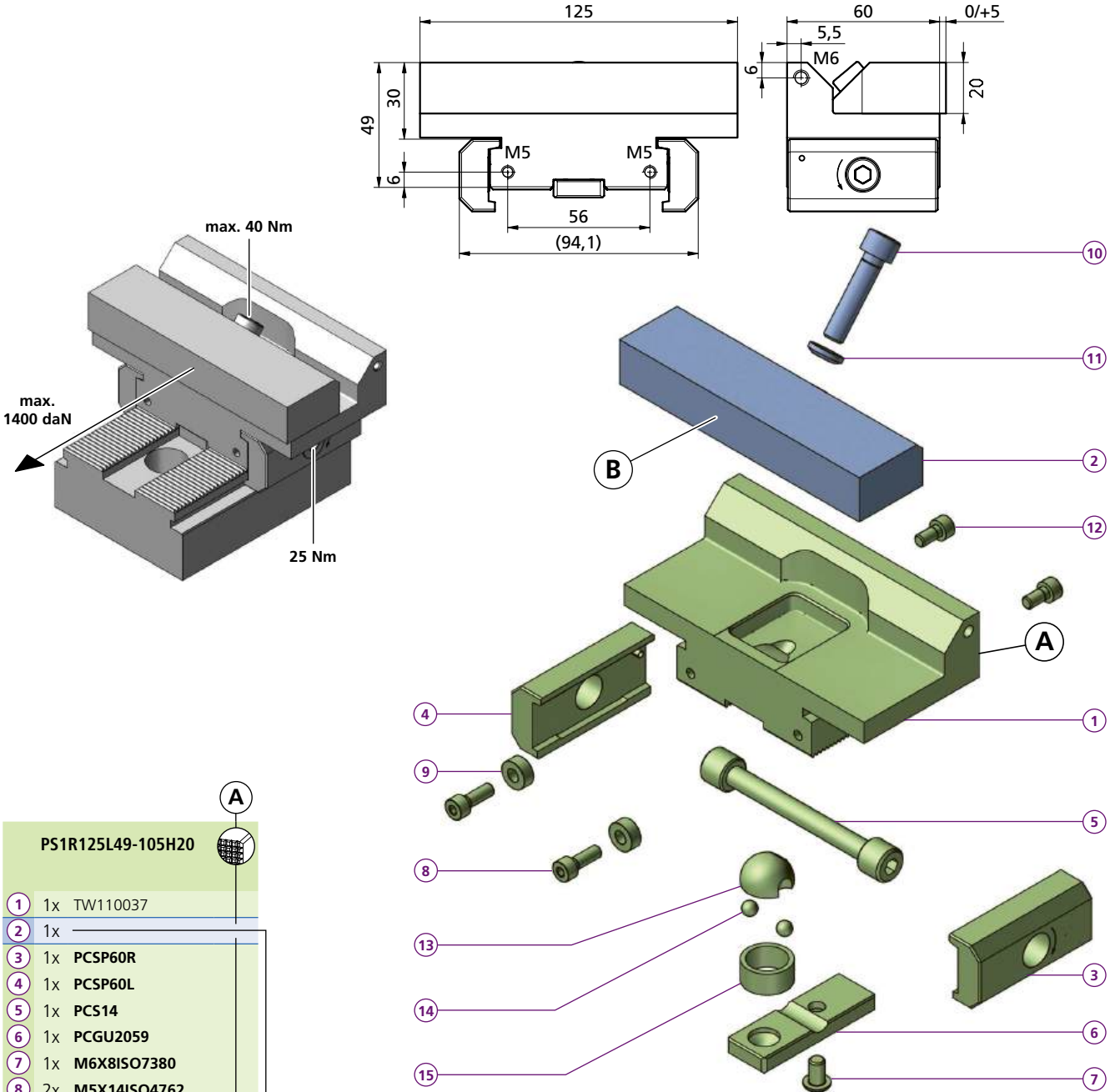

PS1R125L49-105H20	
1	1x TW110037
2	1x
3	1x PCSP60R
4	1x PCSP60L
5	1x PCS14
6	1x PCGU2059
7	1x M6X8ISO7380
8	2x M5X14ISO4762
9	2x PCD005
10	1x M8X35ISO4762
11	1x PCUSR14
12	2x M5X10ISO4762
13	1x PCKMR45M8
14	2x D=6 DIN 5401
15	1x PCD20L095
kg	~1,7

PS1F125L49-105H20	
1	1x TH150895
X	= 125
kg	~1,7

Bestellbeispiel / Ordering example: 1x PS1R125L49-105H20 & 1x B132H20P

	B130H20P	B131H20P	B132H20P
C	125	125	125
H	20	20	20
L	47	47	47
i	HV700 x0,2mm	HV700 x0,2mm	*
kg	~0,71	~0,71	~0,71

B130H20P, B131H20P, B132H20P	
C	Dimension
H	Dimension
L	Dimension
P	± 4°

\* = weicher Stahl / soft steel

Separat bestellen / Order separately

# Linear- Spannbacken ... Linear clamping jaws ...



powerCLAMP

zum Einsatz in unterschiedlichen Spannsituationen  
for use in different clamping situations

Art. Nr.				kg
<b>B110</b>	HV700 x 0,2mm			~0,49
<b>B110P</b>	HV700 x 0,2mm	$\pm 4^\circ$		~0,49



mit Prägeeinsätzen  
with direct-stamping inserts

Art. Nr.			kg
<b>B110P-PRGM8</b>	HV700 x 0,2mm		~0,46

Art. Nr.				kg
<b>B111</b>	HV700 x 0,2mm			~0,48
<b>B111P</b>	HV700 x 0,2mm	$\pm 4^\circ$		~0,48
<b>B112</b>	weicher Stahl soft steel (1.2312)			~0,49
<b>B112P</b>	weicher Stahl soft steel (1.2312)	$\pm 4^\circ$		~0,49
<b>B112HG</b>	Hochgenau High-precision			~0,49
<b>B112E</b>	Einsatzstahl (1.5752) Case hardening steel			~0,49
<b>B112EP</b>	Einsatzstahl (1.5752) Case hardening steel	$\pm 4^\circ$		~0,47
<b>B113</b>	HV700 x 0,2mm			~0,39
<b>B113P</b>	HV700 x 0,2mm	$\pm 4^\circ$		~0,39
<b>B117P</b>	57HRC	$\pm 4^\circ$		~0,46
<b>B120</b>	57HRC			~0,4
<b>B120P</b>	57HRC	$\pm 4^\circ$		~0,4
<b>B122P</b>	57HRC	$\pm 4^\circ$		~0,37
<b>B123P</b>	57HRC	$\pm 4^\circ$		~0,21

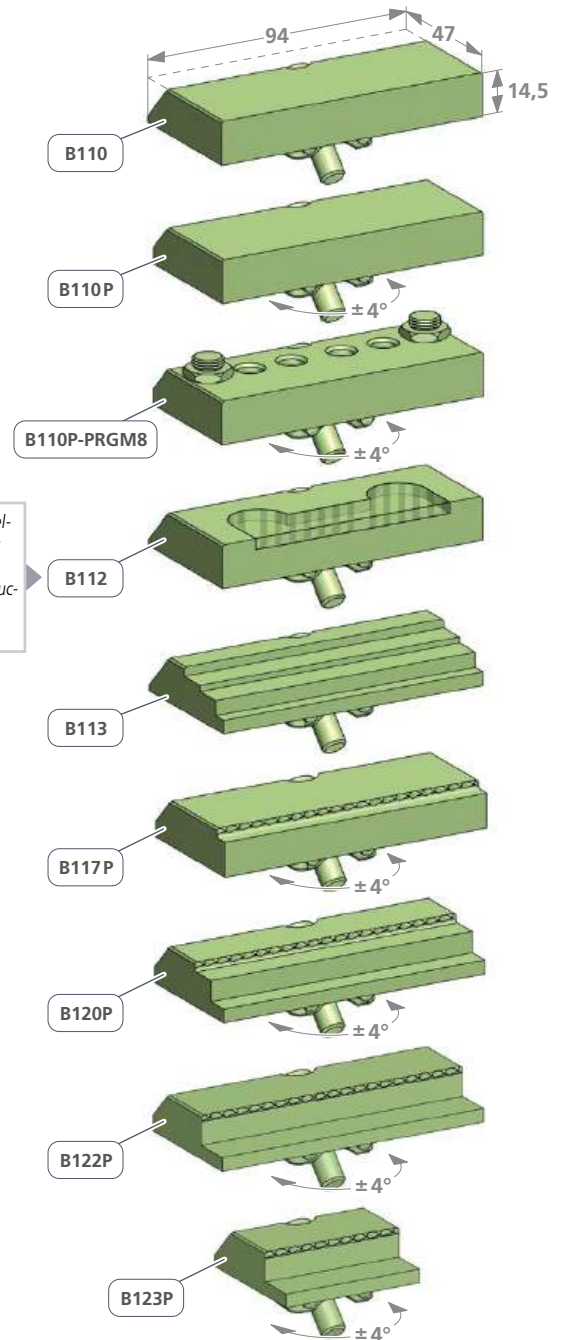

Weich, zur Herstellung individueller Formbacke.  
Soft, for the production of individual moulding jaw.

## Modulhöhen / Module heights 34 / 49 mm

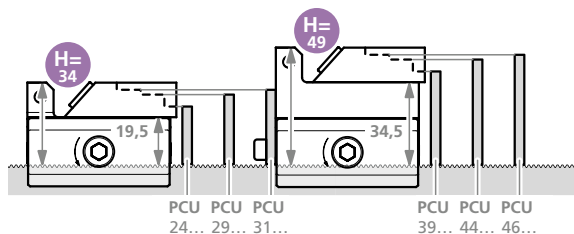

Beim Einsatz einer Stufenbacke, ist die richtige Modulspannhöhe 34 mm / 49 mm zu berücksichtigen. Die Werkstücke auf der Anschlagseite werden mit den passenden Parallelunterlagen abgestützt.

When using a step jaw is applied, the correct module clamping height 34 mm / 49 mm must be taken into account. The workpieces on the end module are supported with the appropriate steel parallel.

## Eingesetzte Stufenbacken / Inserted stepped jaws (B113)

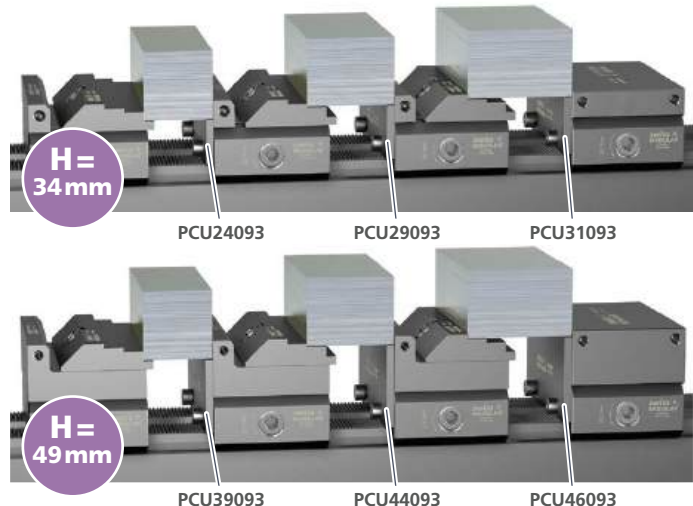

# Linear- Spannbacken ... Linear clamping jaws ...

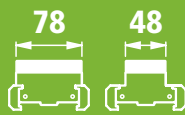

powerCLAMP

zum Einsatz in unterschiedlichen Spannsituationen  
for use in different clamping situations

Art.Nr.				kg
<b>B140</b>	HV700 x 0,2mm			~0,41
<b>B140P</b>	HV700 x 0,2mm	$\pm 4^\circ$		~0,41
<b>B141</b>	HV700 x 0,2mm			~0,41
<b>B141P</b>	HV700 x 0,2mm	$\pm 4^\circ$		~0,41
<b>B105</b>	HV700 x 0,2mm			~0,27
<b>B105P</b>	HV700 x 0,2mm	$\pm 4^\circ$		~0,27
<b>B105-15</b>	HV700 x 0,2mm			~0,27
<b>B106</b>	HV700 x 0,2mm			~0,27
<b>B106P</b>	HV700 x 0,2mm	$\pm 4^\circ$		~0,27
<b>B107</b>	weicher Stahl soft steel (1.2312)			~0,27
<b>B107P</b>	weicher Stahl soft steel (1.2312)	$\pm 4^\circ$		~0,27
<b>B108</b>	HV700 x 0,2mm			~0,22
<b>B108P</b>	HV700 x 0,2mm	$\pm 4^\circ$		~0,22
<b>B115</b>	57HRC			~0,21
<b>B115P</b>	57HRC	$\pm 4^\circ$		~0,21
<b>B116P</b>	57HRC	$\pm 4^\circ$		~0,25

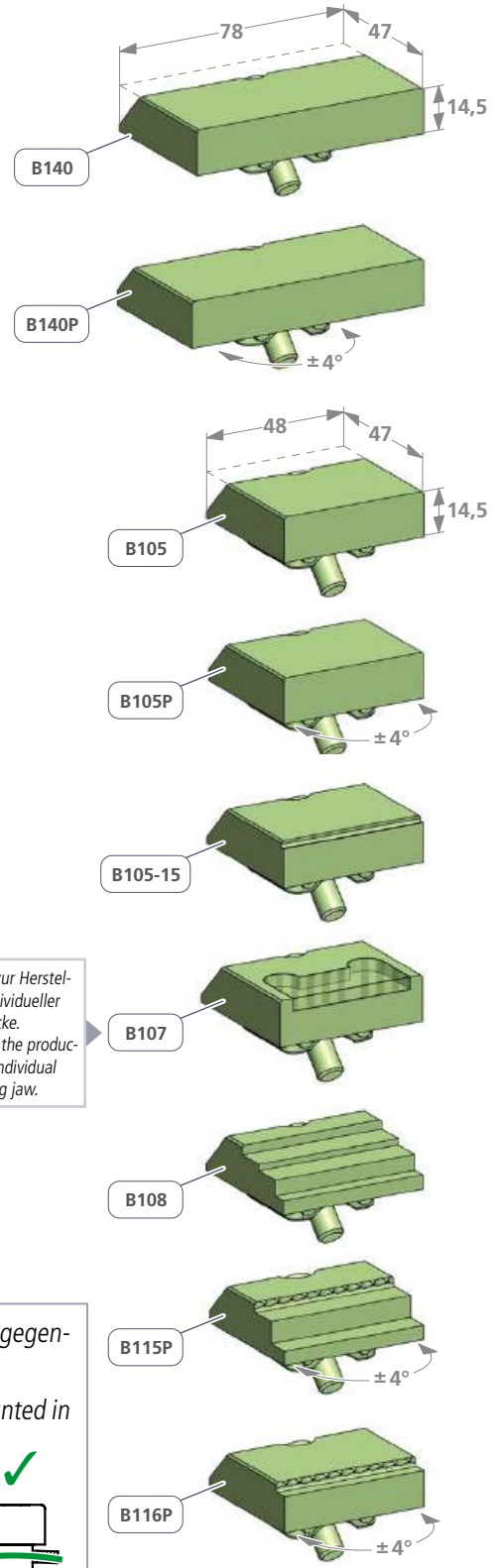

## Für Prägebacken / For stamping jaws

**PF-SET** Kräfteerhaltung mit Nachfederung  
Spring loaded mechanism to maintain clamping force

Bei allen Prägebacken kann die Kräfteerhaltung mit den nachfedernden Tellerfedern eingesetzt werden um ein Freiwigeln des Werkstücks zu verhindern.

On every spring loaded stamping jaw, the force retention with the disc springs can be used to prevent the workpiece from wiggling free.



Die Tellerfedern werden gegenläufig montiert.

The disc springs are mounted in opposite directions.

## Detailvermessung der Stufenbacken / Detailed dimensioning of the stepped jaws

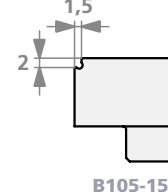
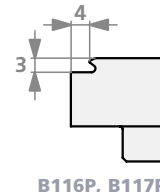
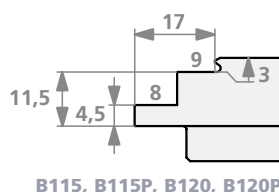
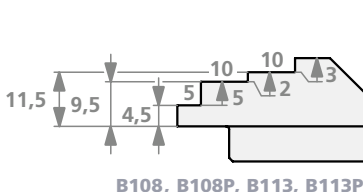

# Anschlagmodule ... End module ...



# 5axes powerCLAMP

für die horizontale und vertikale Bearbeitung  
for horizontal and vertical machining

Art. Nr.	kg	X
<b>PAND19-49</b>	~1,2	19
<b>PAND26-49</b>	~1,3	26
<b>PAND34-49</b>	~1,4	34

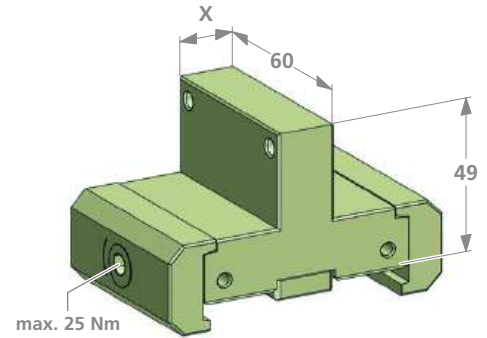

Schmale Anschlagmodule und Werkstücke  
in der Mehrfachspannung.

Slim stop modules and workpieces in  
multiple clamping.

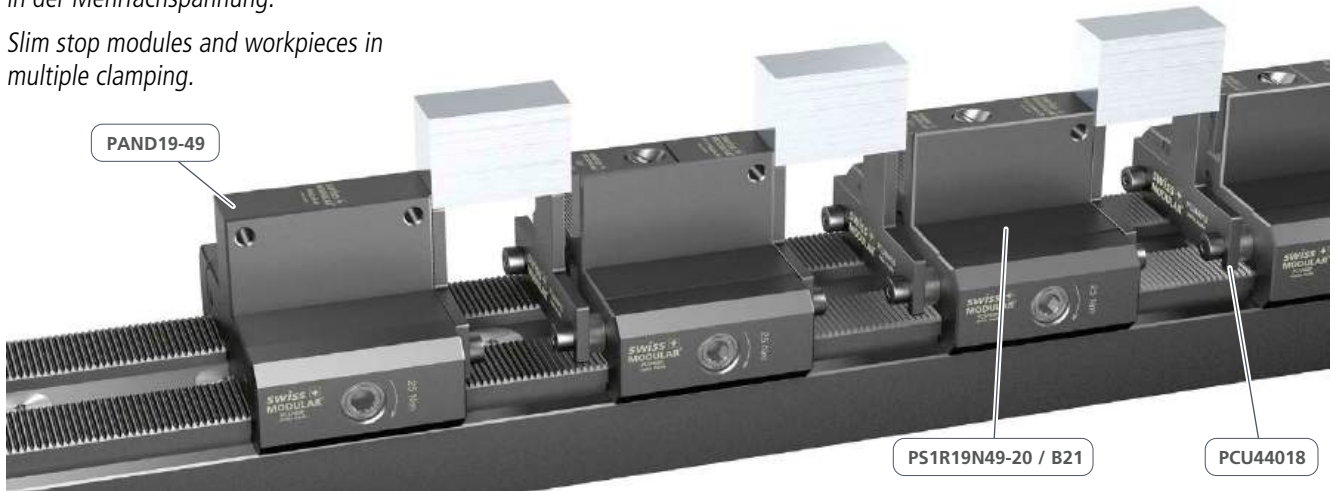

für 5-Achs Bearbeitung  
for 5-axis machining

Art. Nr.	kg	X
<b>PA5X19-49F</b>	~1,1	19
<b>PA5X19-49R</b>	~1,1	19
<b>PA5X26-49F</b>	~1,1	26
<b>PA5X26-49R</b>	~1,1	26
<b>PA5X34-49F</b>	~1,2	34
<b>PA5X34-49R</b>	~1,2	34

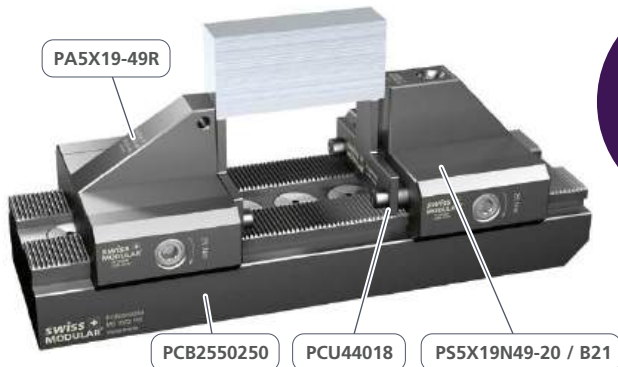
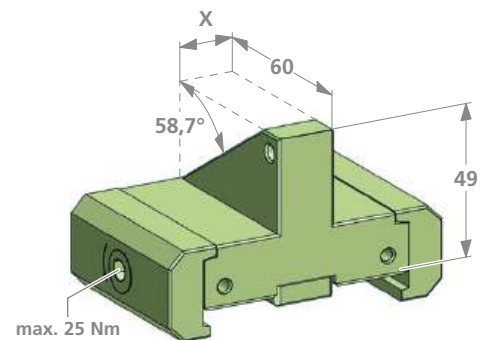

Module einsetzbar auf Zentrischspannern oder Basisschienen.  
Modules can be used on self centrig vises or base rails.



# Anschlagmodule ... End module ...

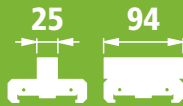

powerCLAMP

für die horizontale und vertikale Bearbeitung  
for horizontal and vertical machining

Art. Nr.	kg
<b>PAND25-44</b>	~0,9

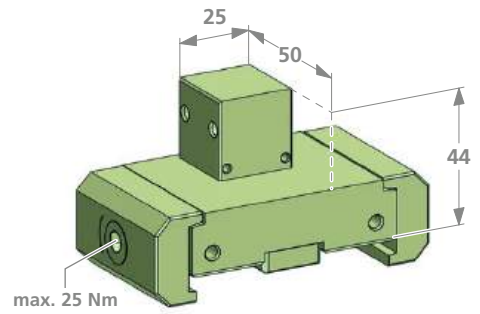

Schlankes und kurzes Anschlagmodul für Kleinteil-Serien (Mehrfachspannung).

Slim and short end module for small part series (Multiple workholding).

Art. Nr.	kg
<b>PAND94-44</b>	~1,3

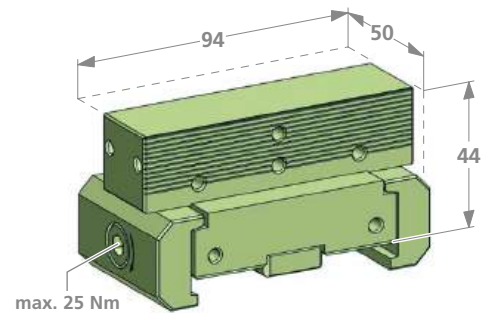

Die Anschlagfläche enthält 2 Passbohrungen. Mit MS50 Passschrauben kann mittig ein Seitenanschlag präzise platziert werden.

The stop surface contains 2 fitting holes. A side stop can be placed precisely in the centre with MS50 fitting screws.

Anschlagmodul mit Doppelspannfunktion. Verdoppelt die Anzahl Spannbereiche auf gleichbleibendem Raum.

End module with double clamping function. Doubles the number of clamping areas in the same amount of working space.



ein Beispiel / one example

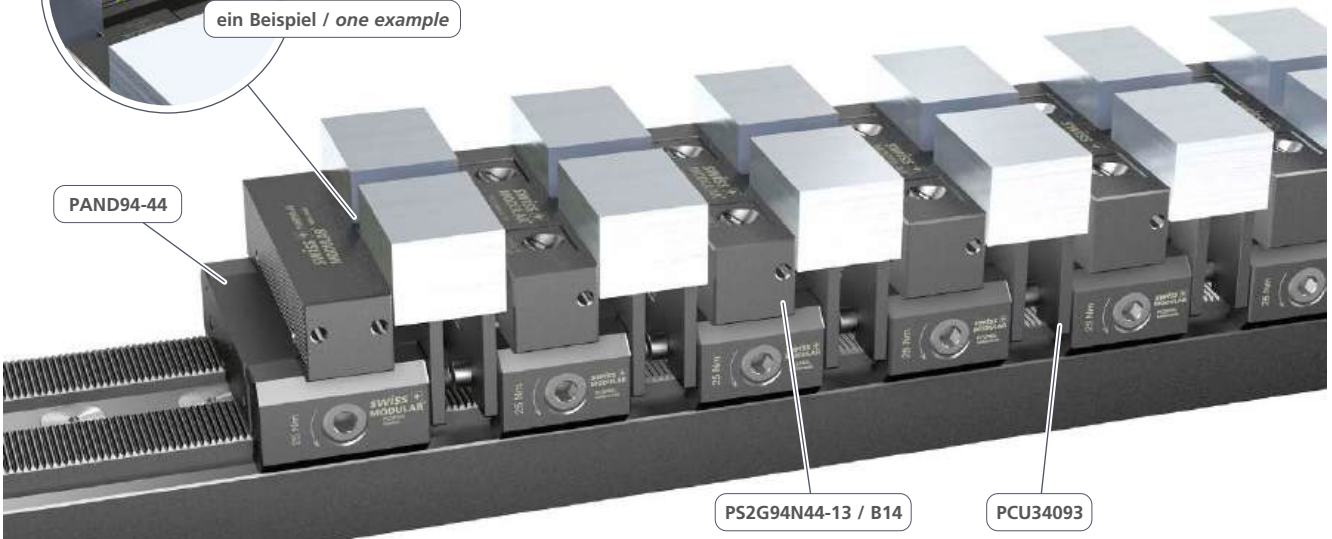

Anschlagmodule ...  
End module ...

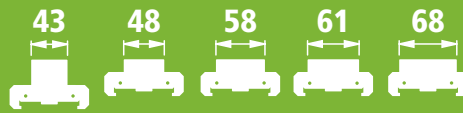

5axes  
powerCLAMP

für die horizontale und vertikale Bearbeitung  
for horizontal and vertical machining

Art. Nr.		kg	X	H
PAND43-49		~1,6	43	49
PAND48-34		~1,3	48	34
PAND48-49		~1,6	48	49
PAND48-75		~2,2	48	75
PAND58-34		~1,4	58	34
PAND58-49		~1,8	58	49
PAND61-34		~1,4	61	34
PAND68-34		~1,4	68	34

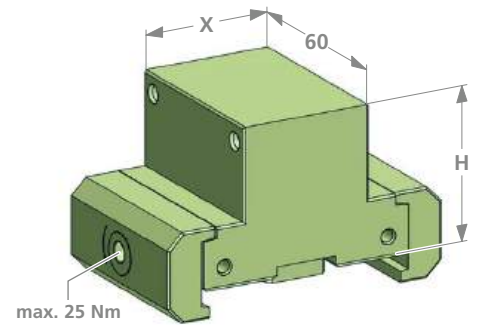

43 mm bis 68 mm breite Anschlagmodule für die Einzel- und Mehrfachspannung.  
43 mm to 68 mm wide end modules for single and multiple clamping.



für 5-Achs Bearbeitung  
for 5-axis machining

Art. Nr.		kg	X
PA5X43-49F		~1,3	43
PA5X43-49R		~1,3	43
PA5X48-49F		~1,4	48
PA5X48-49R		~1,4	48



Module einsetzbar auf Zentrischspannern oder Basisschienen.  
Modules can be used on self centrig vises or base rails.

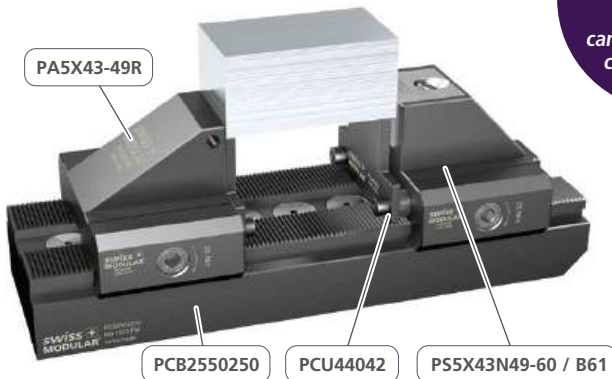
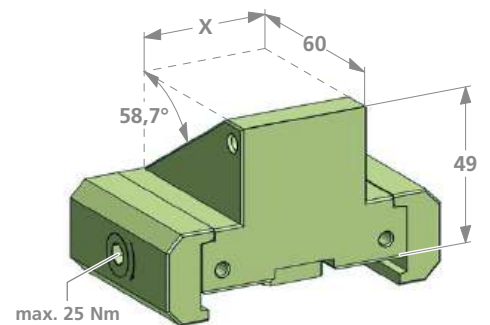

# Anschlagmodule ... End module ...



**5axes**  
**powerCLAMP**

für die horizontale und vertikale Bearbeitung  
for horizontal and vertical machining

Art. Nr.	kg	X	H
<b>PAND78-34</b>	~1,5	78	34
<b>PAND78-49</b>	~2,1	78	49
<b>PAND94-34</b>	~1,6	94	34
<b>PAND94-49</b>	~2,3	94	49
<b>PAND125-49</b>	~2,7	125	49

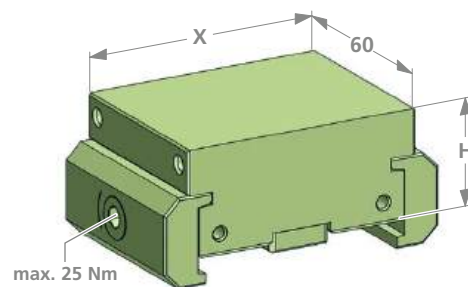

78 mm bis 125 mm breite Anschlagmodule  
für die Einzel- und Mehrfachspannung.

78 mm to 125 mm wide end modules for  
single and multiple clamping.



für 5-Achs Bearbeitung  
for 5-axis machining

Art. Nr.	kg	X
<b>PA5X94-49F</b>	~1,8	94
<b>PA5X94-49R</b>	~1,8	94
<b>PA5X125-49F</b>	~2,0	125
<b>PA5X125-49R</b>	~2,0	125

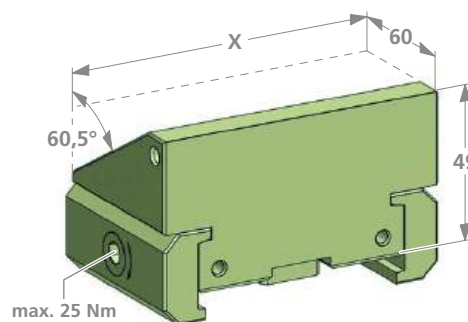

Module  
einsetzbar auf  
Zentrischspannern  
oder Basisschienen.  
Modules  
can be used on self  
centrig vises or  
base rails.

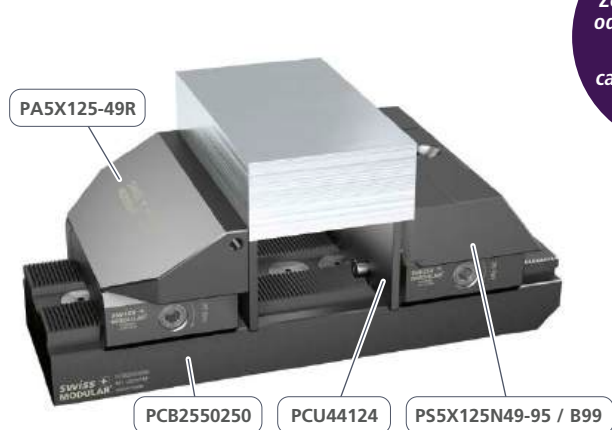

PAND48-34PRG/F-A1

PAND48-49PRG/F-A1

PAND94-34PRG/F-A1



PAND94-49PRG/F-A1



PAND125-49PRG-A1



5axes

powerCLAMP

**PAND48-34PRG-A1**   

**PAND48-34PRF-A1**   

1x TH120684

1x TK140239

3x PCSP60R

4x PCSP60L

5x PCS14

6x PCGU2049

7x M6X8ISO7380

12x M5X10ISO4762

X = 48

H = 34



H1 = 15

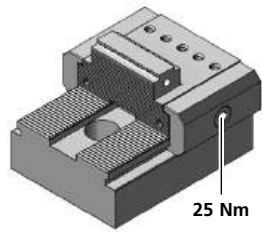

kg ~1,1

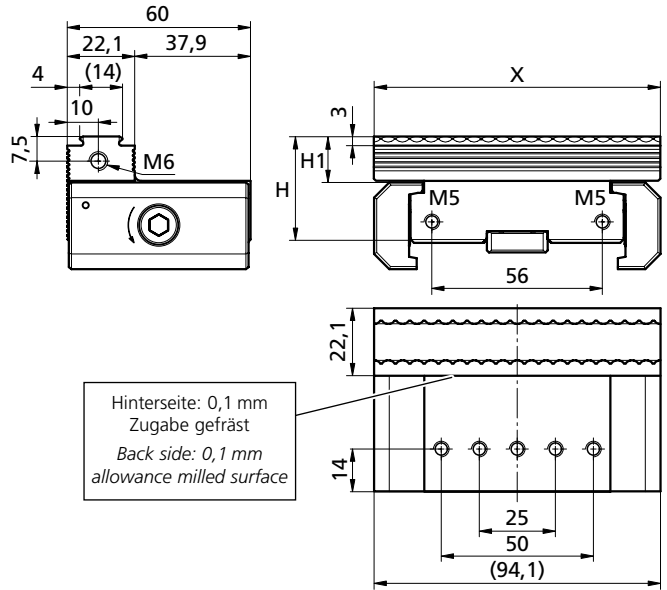

25 Nm



**PAND48-49PRG-A1**   

**PAND48-49PRF-A1**   

1x TH120685

1x TK140597

X = 48

H = 49



H1 = 30

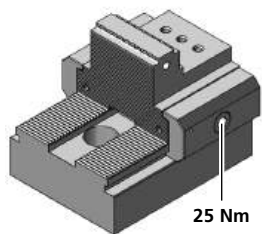

kg ~1,3

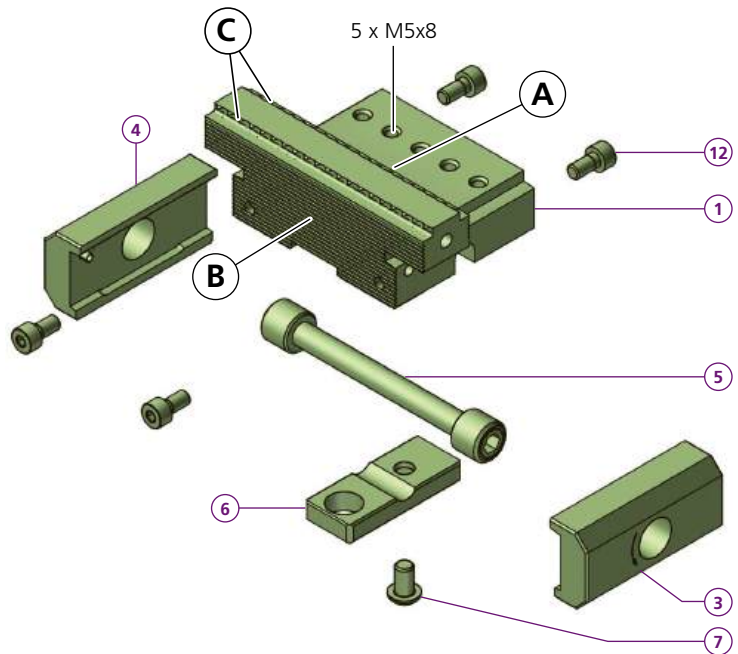

25 Nm



**PAND94-34PRG-A1**   

**PAND94-34PRF-A1**   

1x TH120686

1x TH140185

X = 94



H = 34

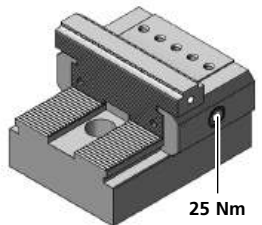

H1 = 15

kg ~1,2



25 Nm

**PAND94-49PRG-A1**   

**PAND94-49PRF-A1**   

1x TH120687

1x TH130754

X = 94



H = 49

H1 = 30

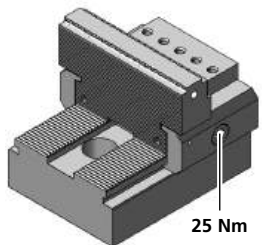
kg ~1,6



25 Nm

**PAND125-49PRG-A1**   

1x TB160295

X = 125

H = 49

H1 = 30

kg ~1,7

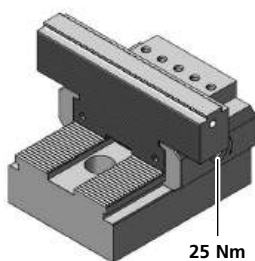

25 Nm

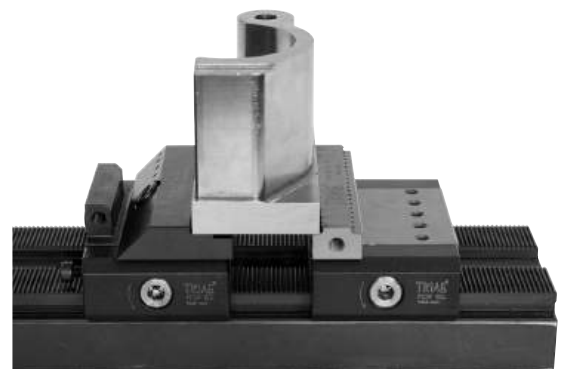

Bestellbeispiel / Ordering example: PAND94-34PRG-A1

PAND125-34PRG-A1

PAND150-34PRG-A1

PAND94-34PRGV

PAND94-49PRGV



prägen  
stamping

5axes

powerCLAMP

X = 125

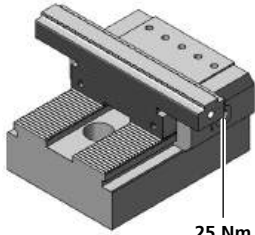

25 Nm

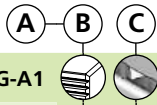

**PAND125-34PRG-A1**

- ① 1x TB180899
- X = 125
- kg ~1,2

**PAND150-34PRG-A1**

- ① 1x TB160145
- ③ 1x PCSP50R
- ④ 1x PCSP50L
- ⑤ 1x PCS14
- ⑥ 1x PCGU2049
- ⑦ 1x M6X8ISO7380
- ⑫ 4x M5X10ISO4762
- X = 150
- kg ~1,2

X = 150

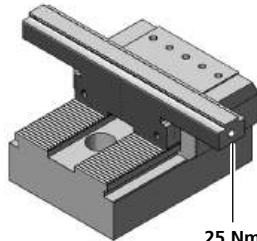

25 Nm

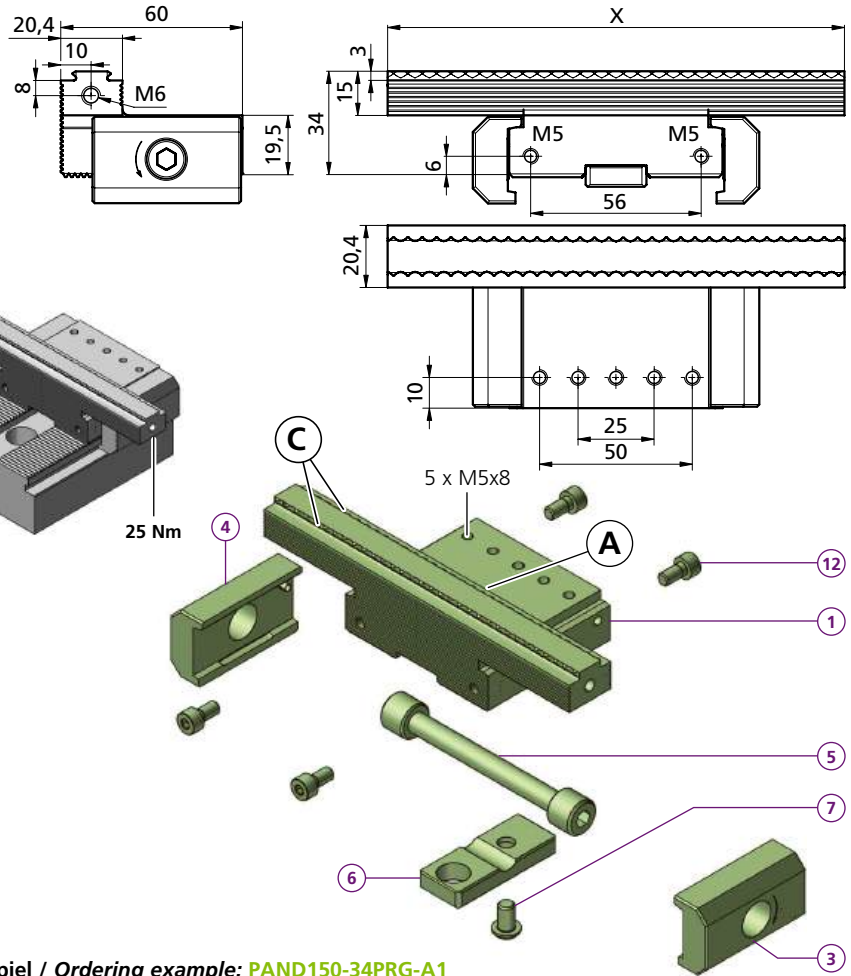

Bestellbeispiel / Ordering example: PAND150-34PRG-A1

H = 34

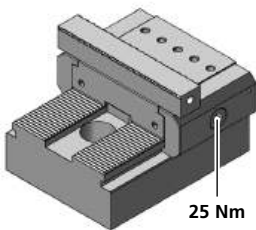

25 Nm



**PAND94-34PRGV**

- ① 1x TH171180
- ③ 1x PCSP60R
- ④ 1x PCSP60L
- ⑤ 1x PCS14
- ⑥ 1x PCGU2049
- ⑦ 1x M6X8ISO7380
- ⑫ 4x M5X10ISO4762
- H = 34
- H1 = 15
- A = 17,5
- kg ~1,2

**PAND94-49PRGV**

- ① 1x TH171179
- H = 49
- H1 = 30
- A = 17
- kg ~1,6

H = 49

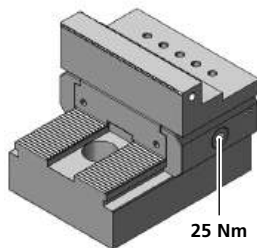

25 Nm

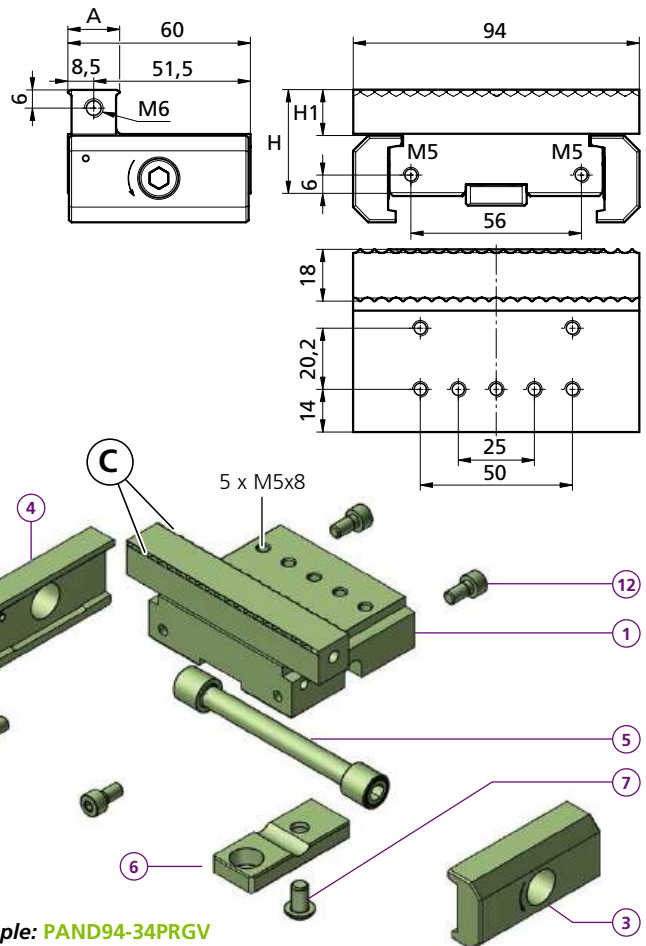

Bestellbeispiel / Ordering example: PAND94-34PRGV

# Anschlagmodule zum Prägen ... End modules for stamping ...



**5axes  
powerCLAMP**

für die horizontale und vertikale Bearbeitung  
for horizontal and vertical machining

Art. Nr.		kg	Z	H
<b>PAND78-34UPRG</b>		~1,2	60	34
<b>PAND78-49UPRG</b>		~1,5	60	49
<b>PAND78-34X50UPRG</b>		~1,0	50	34

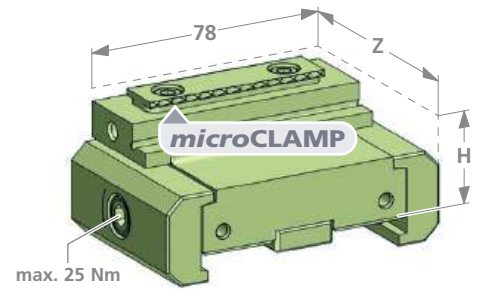

Art. Nr.		kg
<b>PAND120-49UPRG</b>		~1,8

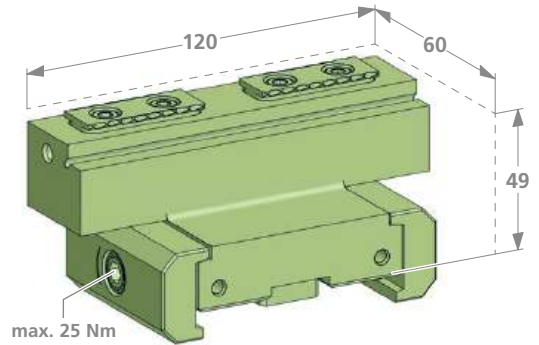

Art. Nr.		kg
<b>PANF94-34PRGM8</b>		~1,5

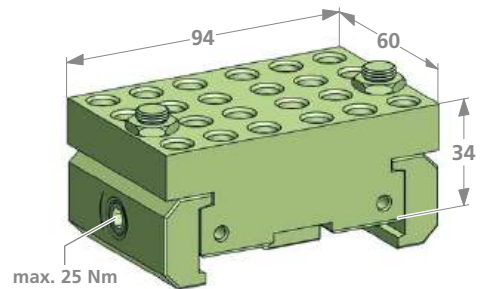

Module einsetzbar auf Zentrischspannern oder Basisschienen.

Modules can be used on self centrig vises or base rails.

Der Einsatz dieser Spannmodule erweitert die Spannmöglichkeiten für runde und unförmige Werkstücke erheblich.

The use of these clamping modules expands the clamping possibilities for round and bulky workpieces considerably.



Bei knapp gespannten Werkstücken sind direkt-Prägebacken die ideale Wahl zum spannen.

For tight clamped workpieces, direct stamping jaws are the ideal choice for clamping.

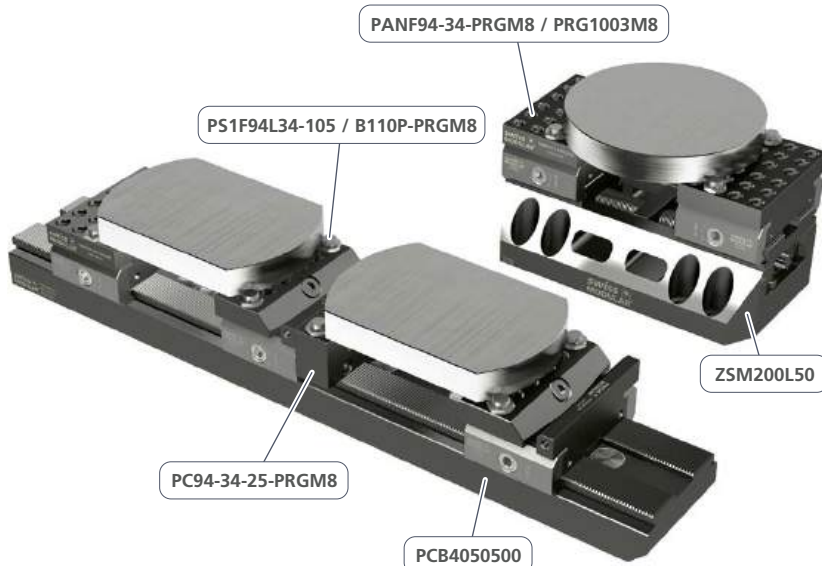

**Rohlingsmodule**  
**Blank module**

**PT-F80-30X60**  
**PT-F80-30X60NS**  
**PT-F80-30X30NS**

**PT-F61-25X60**  
**PT-F61-25X50**  
**PT-F61-25X30**

**5axes**  
**powerCLAMP**

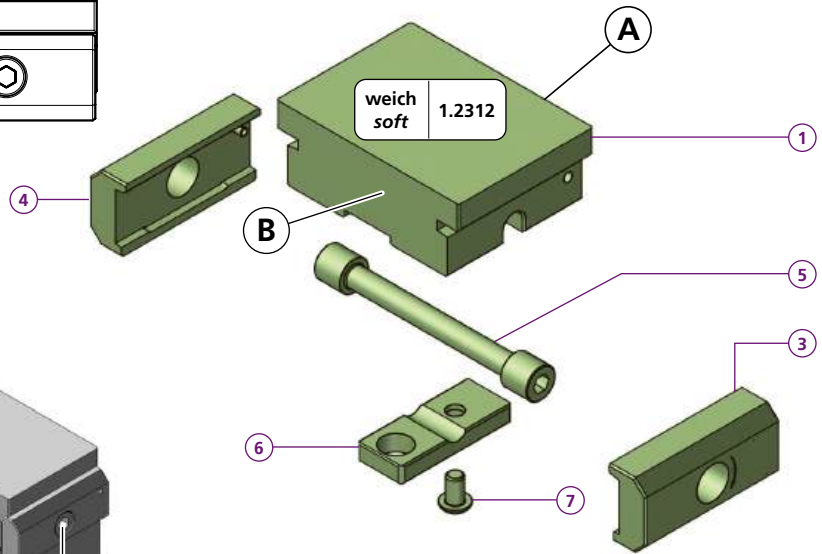
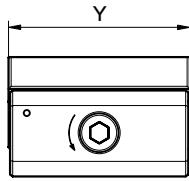
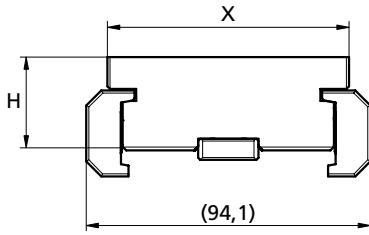

**PT-F80-30X60**

- 1 1x TF140637
- 3 1x PCSP60R
- 4 1x PCSP60L
- 5 1x PCS14
- 6 1x PCGU2049
- 7 1x M6X8ISO7380

X = 80  
H = 30  
Y = 60  
kg ~1,4

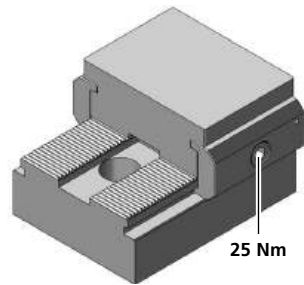

**PT-F80-30X60NS**

NS = Rohlingsmodul freie Positionierung ohne Verzahnung  
Carrier module without positioning serration for free positioning

- 1 1x TF140635
- 3 1x PCSP60R
- 4 1x PCSP60L
- 5 1x PCS14
- 6 1x PCGU2049
- 7 1x M6X8ISO7380

X = 80  
H = 30  
Y = 60  
kg ~1,4

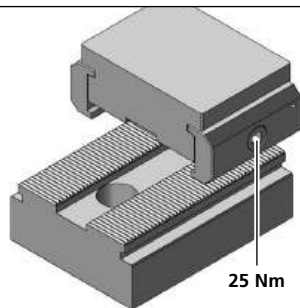

**PT-F80-30X30NS**

NS = Rohlingsmodul freie Positionierung ohne Verzahnung  
Carrier module without positioning serration for free positioning

- 1 1x TF140749
- 3 1x PCSP30R
- 4 1x PCSP30L
- 5 1x PCS14
- 6 1x PCGU2030
- 7 1x M6X8ISO7380

X = 80  
H = 30  
Y = 30  
kg ~0,7

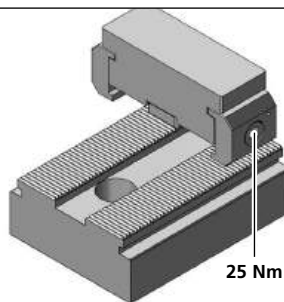

**PT-F61-25X60**

- 1 1x TF140638
- 3 1x PCSP60R
- 4 1x PCSP60L
- 5 1x PCS14
- 6 1x PCGU2049
- 7 1x M6X8ISO7380

X = 61  
H = 25  
Y = 60  
kg ~1,1

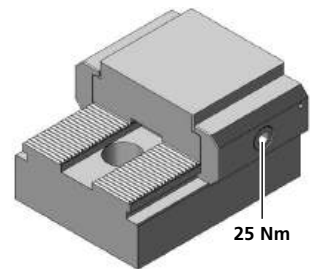

**PT-F61-25X50**

- 1 1x TF140750
- 3 1x PCSP50R
- 4 1x PCSP50L
- 5 1x PCS14
- 6 1x PCGU2049
- 7 1x M6X8ISO7380

X = 61  
H = 25  
Y = 50  
kg ~1,0

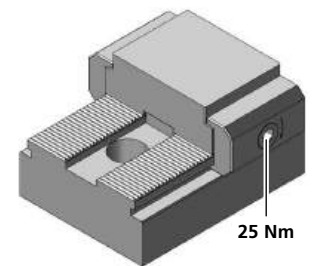

**PT-F61-25X30**

- 1 1x TF140636
- 3 1x PCSP30R
- 4 1x PCSP30L
- 5 1x PCS14
- 6 1x PCGU2049
- 7 1x M6X8ISO7380

X = 61  
H = 25  
Y = 30  
kg ~0,6

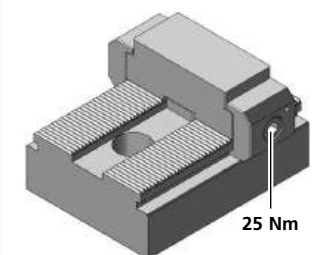

Bestellbeispiel / Ordering example: **PT-F80-30X60**

PR94-49SET

PR94-39-50SET

Rohlingsmodule  
Blank module

PR125-49SETALU  
PT-F132-34RDSET

PR150-49SET  
PR125-49SET

5axes  
powerCLAMP

A B C

**PR94-49SET**

- 1 1x PR94-49
- 3 1x PCSP50R
- 4 1x PCSP50L
- 5 1x PCS14
- 6 1x PCGU2049
- 7 1x M6X8ISO7380

X = 94  
H = 49  
Y = 60,4  
kg ~2,3

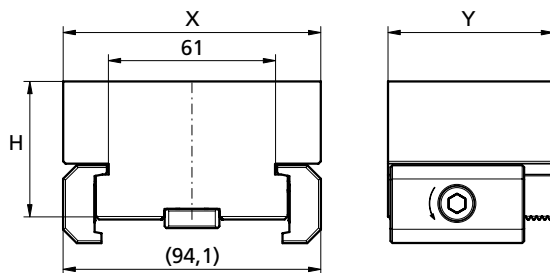
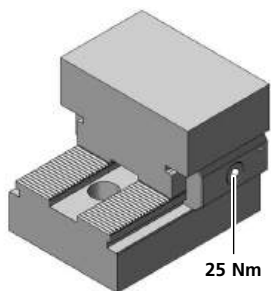

**PR94-39-50SET**

- 1 1x PR94-39-50

X = 94  
H = 39  
Y = 50,4  
kg ~1,6

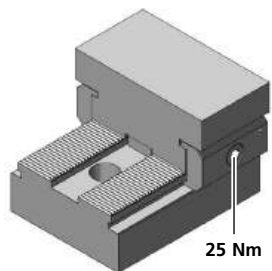

**PR125-49SET**

- 1 1x PR125-49

X = 125  
H = 49  
Y = 60,4  
kg ~2,7

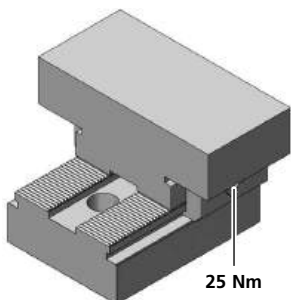

**PR125-49SETALU**

- 1 1x \*PR125-49ALU

X = 125  
H = 49  
Y = 60,4  
kg ~0,83

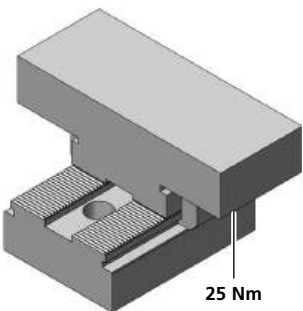

**PR150-49SET**

- 1 1x PR150-49

X = 150  
H = 49  
Y = 60,4  
kg ~3,1

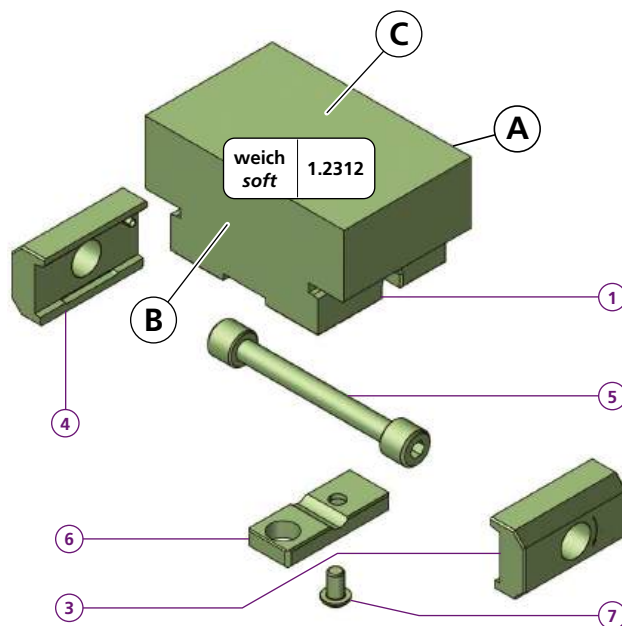
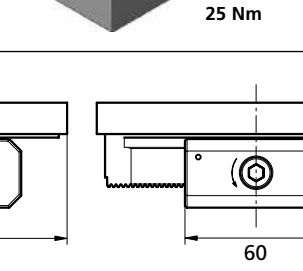

\* ALU = ENAW-7022 Bestellbeispiel / Ordering example: PR94-49SET

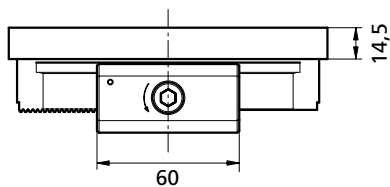
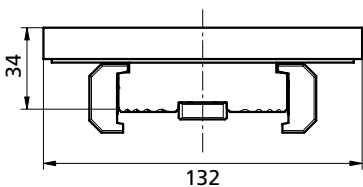

**PT-F132-34RDSET**

- 1 1x PT-F132-34RD
- 3 1x PCSP60R
- 4 1x PCSP60L
- 5 1x PCS14
- 6 1x PCGU2059
- 7 1x M6X8ISO7380

kg ~3,1

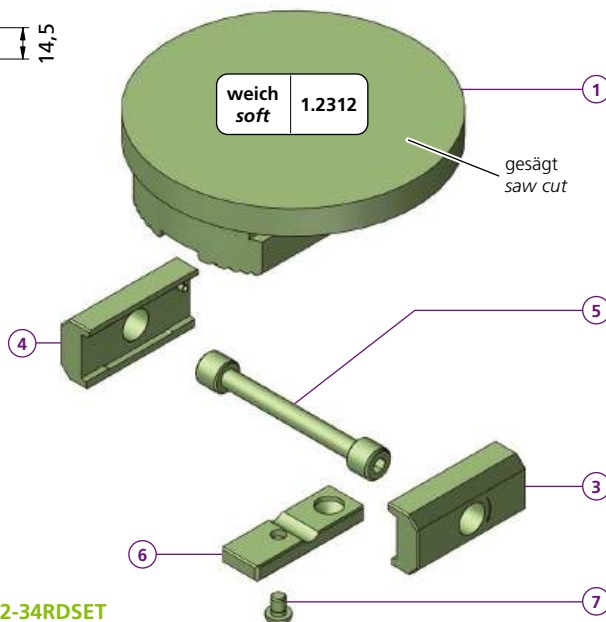
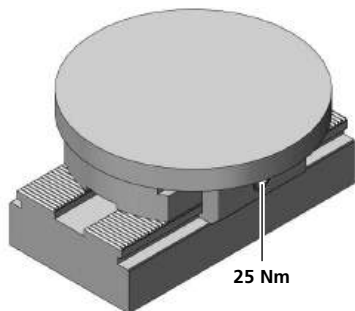

Bestellbeispiel / Ordering example: PT-F132-34RDSET

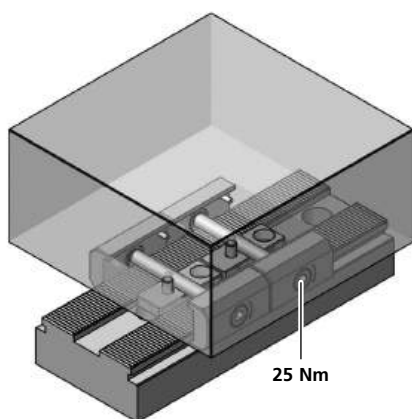
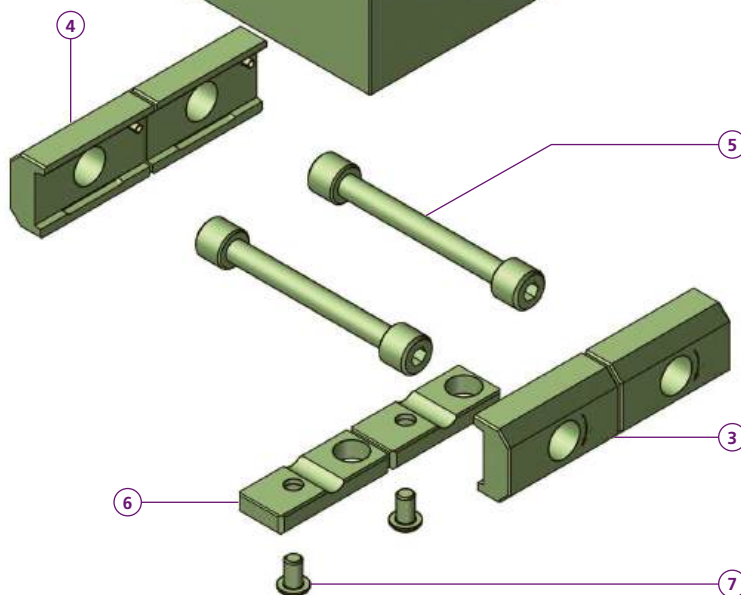
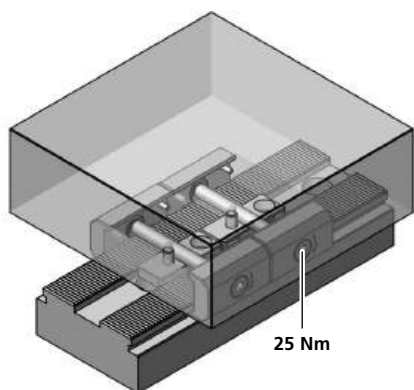
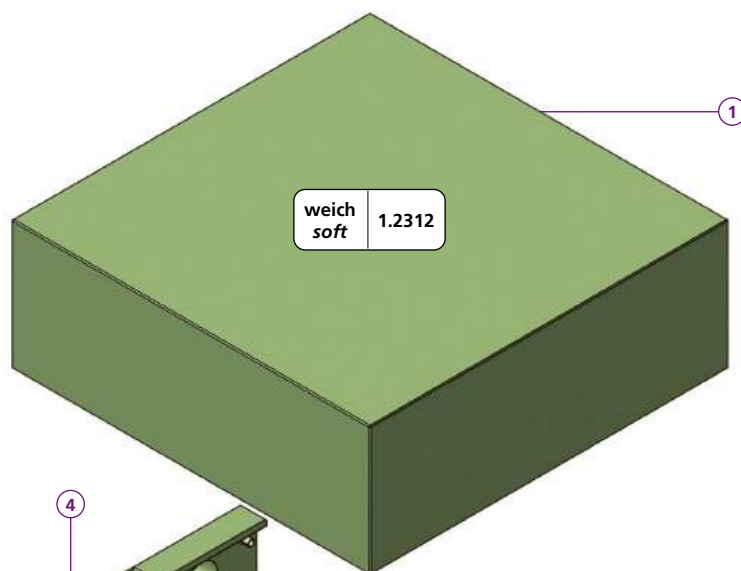
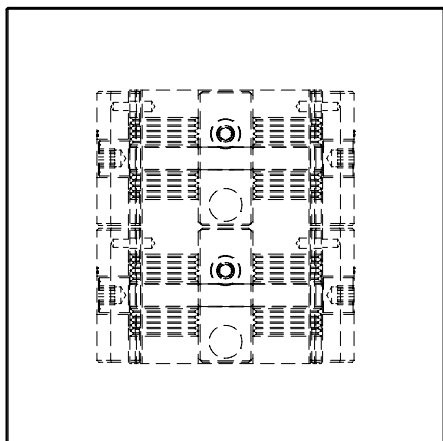
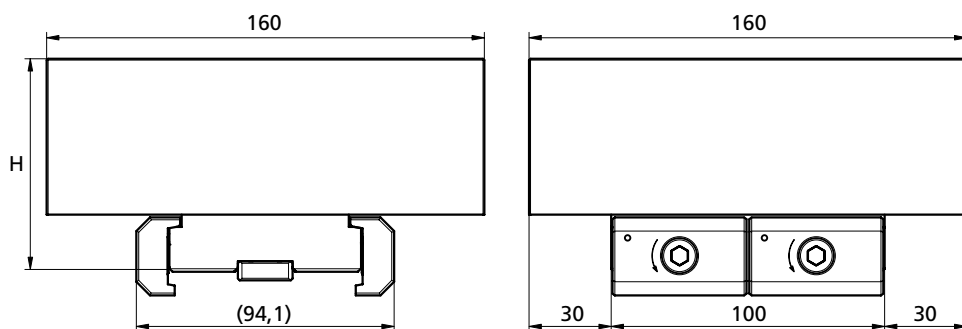

**PTX160-57S**

- ① 1x TH130539
- ③ 2x PCSP50R
- ④ 2x PCSP50L
- ⑤ 2x PCS14
- ⑥ 2x PCGU2049
- ⑦ 2x M6X8ISO7380

H = 57

kg ~9

**PTX160-77S**

- ① 1x TH130723

H = 77

kg ~13

Bestellbeispiel / Ordering example: **PTX160-57S**

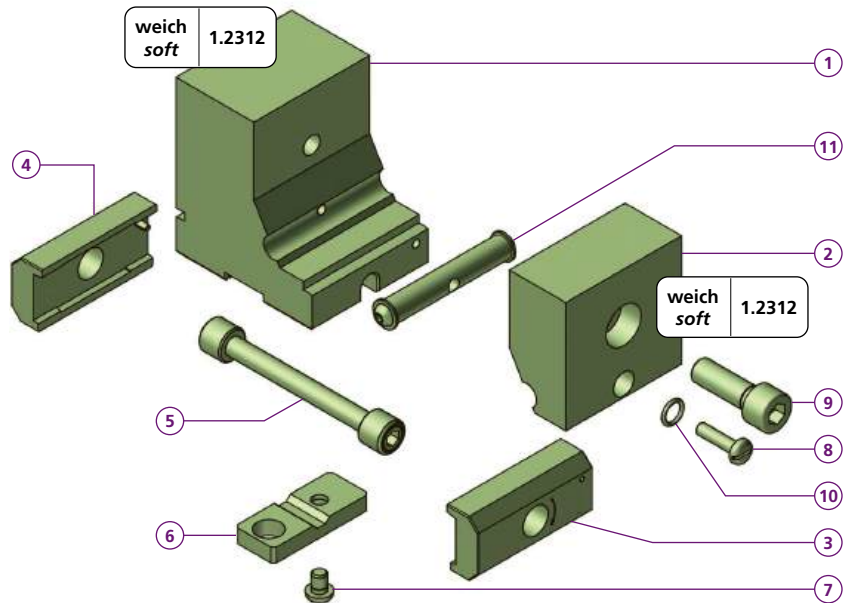
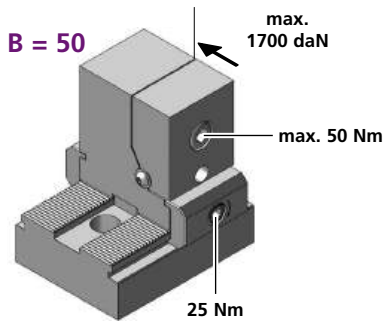
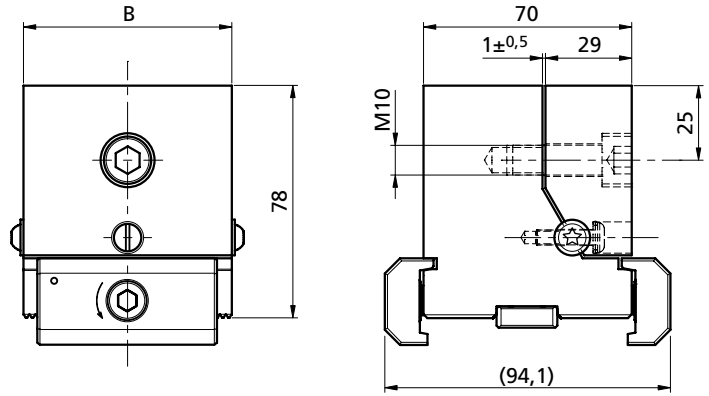
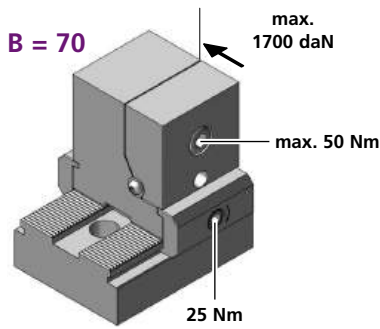

**PS1X70L78ST**

- ① 1x PRS7078AST
- ② 1x PRS7078SST
- ③ 1x PCSP60R
- ④ 1x PCSP60L
- ⑤ 1x PCS14
- ⑥ 1x PCGU2049
- ⑦ 1x M6X8ISO7380
- ⑧ 1x M5X20BN1362
- ⑨ 1x M10X30ISO4762
- ⑩ 1x OR Ø 8x1,5
- ⑪ 1x PRS7078G
- B = 70
- kg ~3,2

**PS1X50L78ST**

- ① 1x PRS5078AST
- ② 1x PRS5078SST
- ③ 1x PCSP50R
- ④ 1x PCSP50L
- ⑪ 1x PRS5078G
- B = 50
- kg ~2,3

**PRS70L78ST**

- ① 1x PRS7078AST
- ② 1x PRS7078SST
- ⑪ 1x PRS7078G
- B = 70
- kg ~2,8

**PRS50L78ST**

- ① 1x PRS5078AST
- ② 1x PRS5078SST
- ⑪ 1x PRS5078G
- B = 50
- kg ~2,0

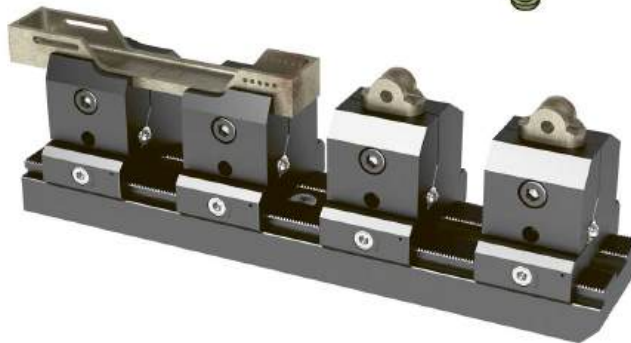

Drehmoment Torque		Spannkraft Workholding force		
Nm	(lb-ft)	~daN	~(lb)	~t
10	7,4	= 400	880	0,4
20	14,8	= 800	1'760	0,8
30	22,2	= 1'200	2'650	1,2
40	29,6	= 1'600	3'530	1,6

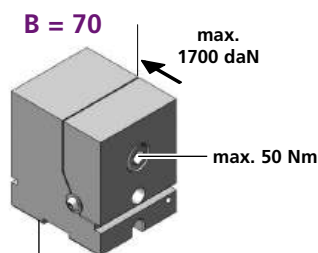

PRS = Rohlingsmodul ohne Spannpratzen  
Blank module side clamp



Spannbacken Rohling auf Kundenwunsch angepasst  
Jaw blank machined to customer specification

Bestellbeispiel / Ordering example: **PS1X70L78ST**



Anschlagmodul für runde Werkstücke  
Endmodule for round workpieces

Art. Nr.		Ø	X	kg
<b>PAND30-34RV12-35</b>		12 – 35	30	~1,1
<b>PAND61-34RV35-80</b>		35 – 80	61	~1,26

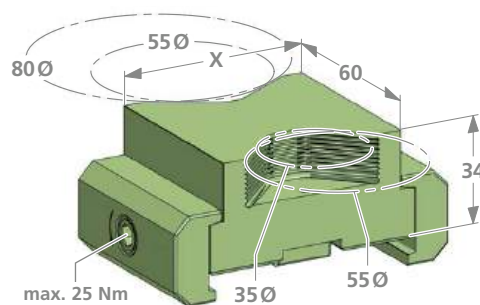
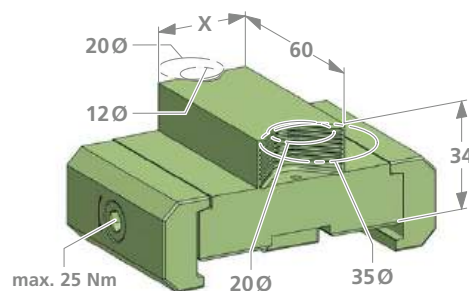

Runde Werkstücke, die einen Durchmesserbereich von 12 – 80 mm abdecken, können auf vielfältige Art gespannt werden.

Round workpieces covering a diameter range from 12 - 80 mm can be clamped in a variety of ways.



Module einsetzbar auf Zentrischspannern oder Basisschienen.  
Modules can be used on self centrig vises or base rails.

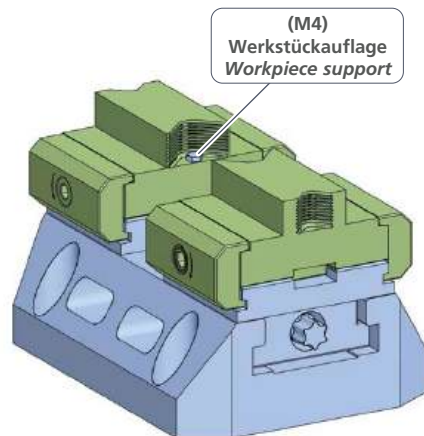

Drehmoment Torque		Spannkraft Workholding force		
Nm	(lb-ft)	~daN	~(lb)	~t
10	7,4	= 200	440	0,2
20	14,8	= 500	1'102	0,5
30	22,2	= 1'000	2'204	1,0
40	29,6	= 1'300	2'866	1,3
50	37,0	= 1'600	3'527	1,6

**NUSS3/8"TX30E14**

**WICHTIG!**  
Bitte separat bestellen  
**IMPORTANT!**  
Please order separately



# Dreibackenfutter Three jaw chuck

# PS3X80L75BSET PS3X100L82BSET PS3X125L87BSET

# 5axes powerCLAMP

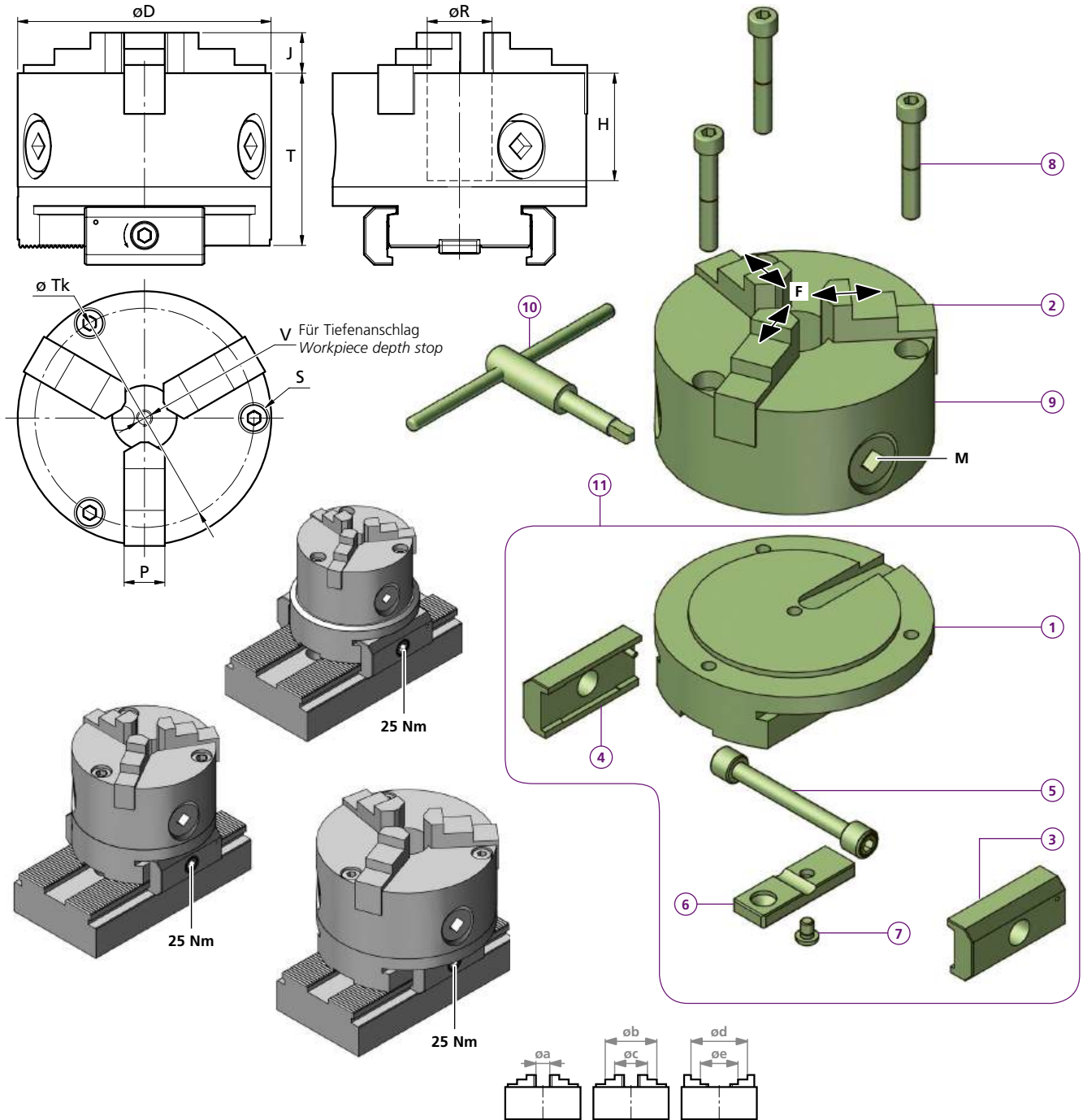

	D	J	T	R	H	P	V	a mm	b mm	c mm	d mm	e mm	M (max.)	F (max.)	$\varnothing T_k$	S
<b>PS3X80L75BSET</b>	80	13	75	15	42,5	10	M6	3...27	48...73	23...48	52...76	27...51	28 Nm	1300 daN	67	M6
<b>PS3X100L82BSET</b>	100	17	82	20	49,5	14	M8	3...39	58...94	24...60	64...100	30...66	38 Nm	1600 daN	83	M8
<b>PS3X125L87BSET</b>	125	19	87	32	55	16	M8	3...49	70...116	30...75	83...125	38...84	55 Nm	2600 daN	108	M8

**PS3X80L75BSET**

- 1 1x TW090013\_01
- 2 2x 3 Stk. / pcs
- 3 1x PCSP60R
- 4 1x PCSP60L
- 5 1x PCS14
- 6 1x PCGU2059
- 7 1x M6X8ISO7380
- 8 3x M6X45ISO4762
- 9 1x 243809.0083220
- 10 1x 243864.0080000
- 11 PTX80-30

kg ~2,8

**PS3X100L82BSET**

- 1 1x TW090012\_01
- 2 2x 3 Stk. / pcs
- 8 3x M8X50ISO4762
- 9 1x 243809.0103220
- 10 1x 243864.0100000
- 11 PTX100-30

kg ~4,3

**PS3X125L87BSET**

- 1 1x TW080027\_01
- 2 2x 3 Stk. / pcs
- 8 3x M8X55ISO4762
- 9 1x 243809.0123220
- 10 1x 243864.0120000
- 11 PTX125-29

kg ~6,3

$\varnothing$	243849.0083200	243850.0083200	*243834.0083300
80	243849.0103200	243850.0103200	*243834.0103300
100	243849.0123200	243850.0123200	*243834.0123300
125			

3x  
\*Weich  
Soft  
16MnCr5

Bestellbeispiel / Ordering example: **PS3X125L87BSET**

Separat bestellen / Order separately

# Spannzangenmodule Collet modules

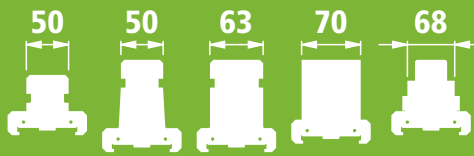

5axes  
powerCLAMP

für die horizontale und vertikale Bearbeitung  
for horizontal and vertical machining

Art. Nr.	kg	Ø	Y	H
<b>PS1X50N62-ER32</b>	~1,3	2-22	60	62
<b>PS1X50N100-ER32</b>	~2,2	2-22	60	100
<b>PS1X63N100-ER40</b>	~2,3	3-29	80	100

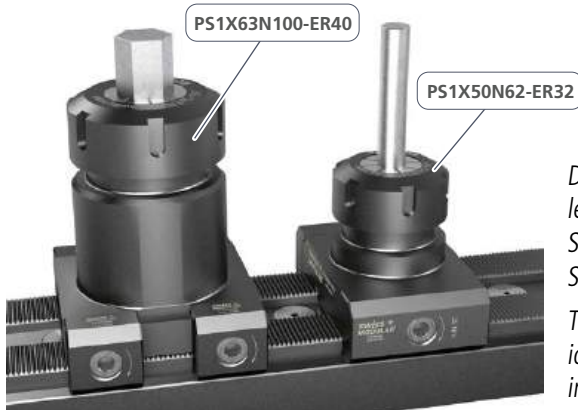
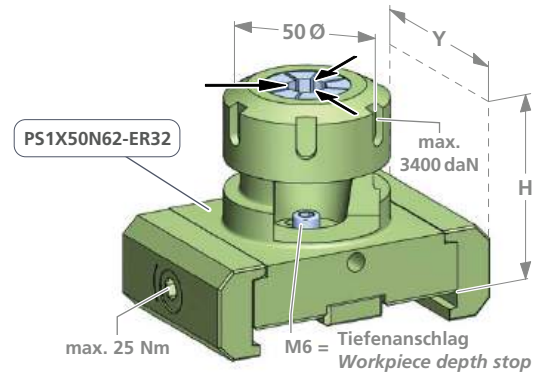

Diese Spannzangenmodule ermöglichen das ideale Spannen und Bearbeiten von Stangenmaterial.

These collet modules enable ideal clamping and machining of bar material.

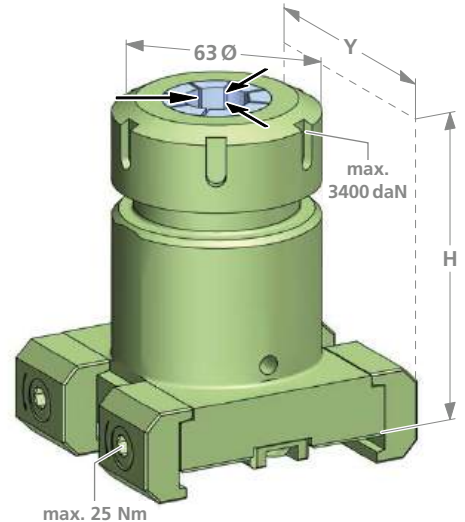

Art. Nr.	kg	Ø
<b>PS1X50N70H-ER32-NS</b>	~2,98	2-22

Die seitlichen Spannpratzen können um 90° gedreht werden, dadurch kann das Spannzangenmodul auch quer zur Schiene platziert werden.

The side clamps can be turned by 90°, the module can therefore be placed crosswise to the rail.

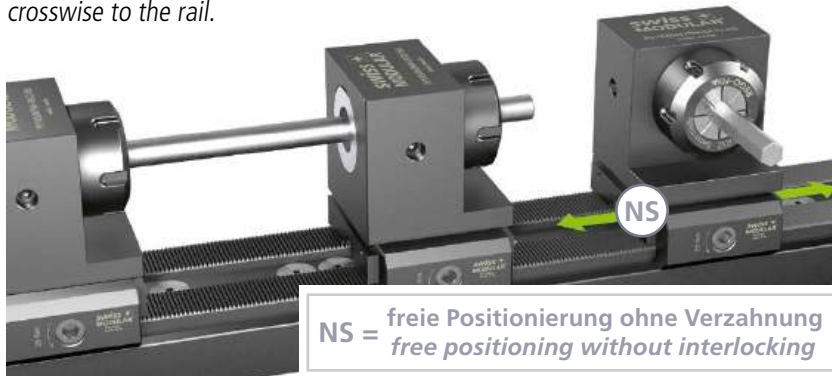

NS = freie Positionierung ohne Verzahnung  
free positioning without interlocking

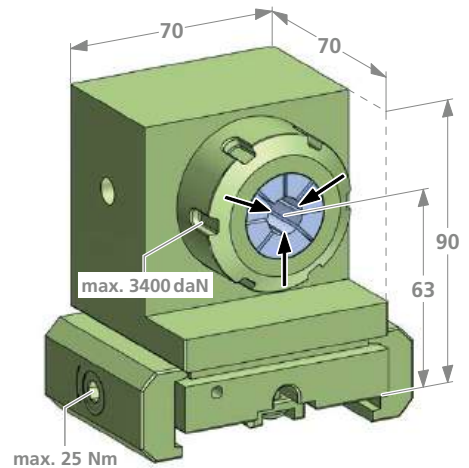

Art. Nr.	kg	Ø	M
<b>PS1X68N80-W20</b>	~1,8	0,5-20	M37,6x3

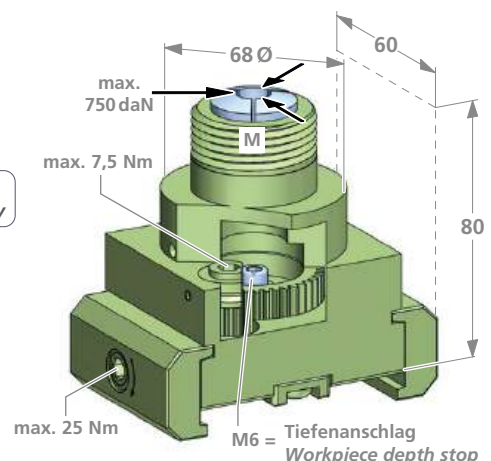

**PS1F-KLD1**  
**PS1F-KLD1NS**

**powerCLAMP**

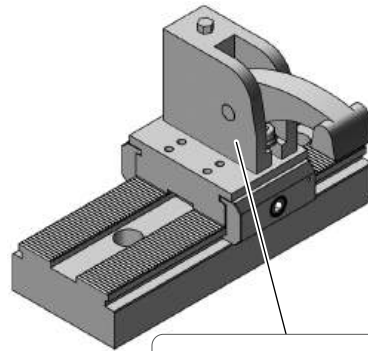
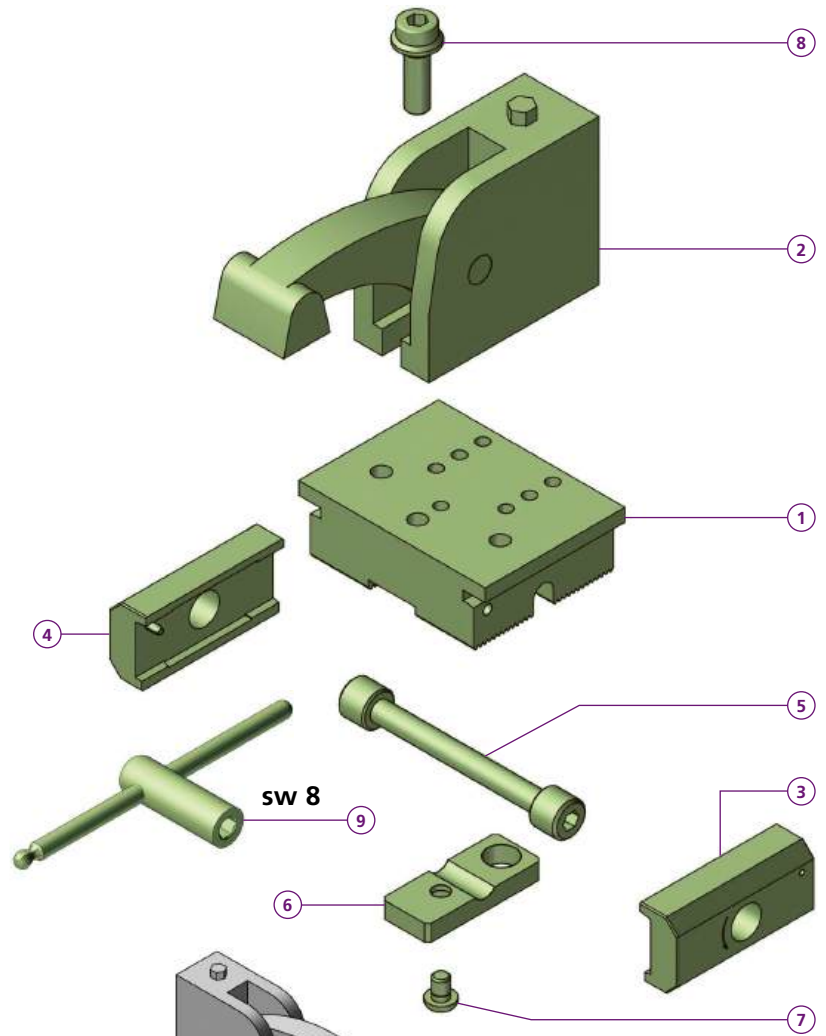
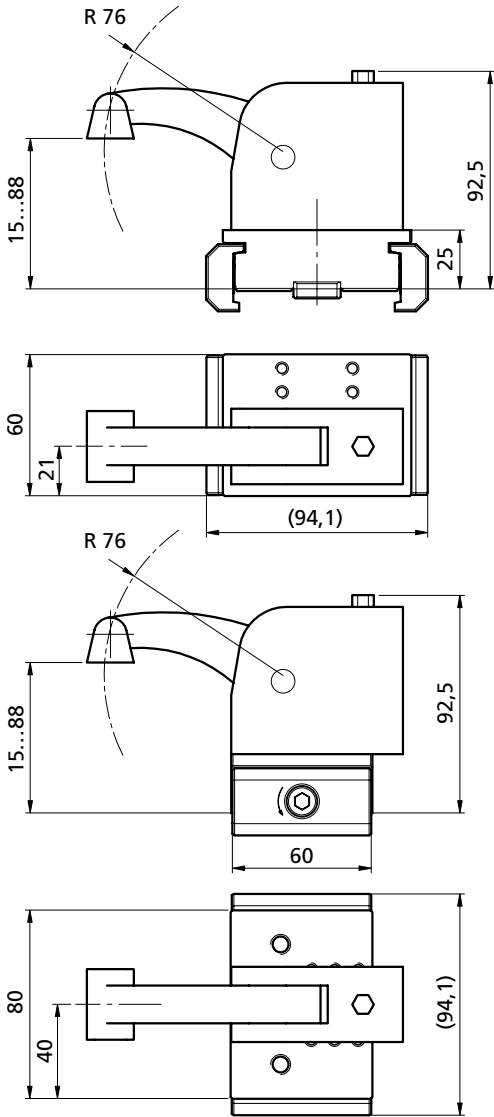

Spanner quer montiert  
Clamp mounted transversely

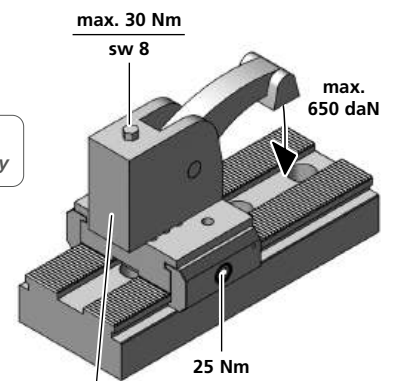

Spanner längs montiert  
Clamp mounted longitudinally



NS = Trägermodul freie Positionierung ohne Verzahnung  
Carrier module without positioning serration for free positioning

PS1F-KLD1	
1	1x PCTMV1F
2	1x 07-020
3	1x PCSP60R
4	1x PCSP60L
5	1x PCS14
6	1x PCGU2049
7	1x M6X8ISO7380
8	1x M8x25 TW080012-02
9	1x 07-180
kg	~2,1

PS1F-KLD1NS	
2	1x PCTMV1FNS
kg	~2,1

Bestellbeispiel / Ordering example: **PS1F-KLD1NS**

**Plattenspanner / Plate clamping modul PS1F20L35BV1**  
**Trägermodul für Micro Zentrischspanner PS1F20L35BV1NS**  
**Support module for micro self centering vise PTX-MCZ40L30 powerCLAMP**

**PS1F20L35BV1**

- ① 1x PCTMV1F
- ② 1x MV1F20L35BV1
- ③ 1x PCSP60R
- ④ 1x PCSP60L
- ⑤ 1x PCS14
- ⑥ 1x PCGU2049
- ⑦ 1x M6X8ISO7380

kg ~1,4

**PS1F20L35BV1NS**

- ① 1x PCTMV1FNS

kg ~1,4

**NS = Trägermodul freie Positionierung ohne Verzahnung**  
*Carrier module without positioning serration for free positioning*

**microCLAMP p. 177**

max. 920 daN    max. 15 Nm

25 Nm

**PTX-MCZ40L30**

- ① 1x TB200682
- ② 1x —
- ③ 1x PCSP60R
- ④ 1x PCSP60L
- ⑤ 1x PCS14
- ⑥ 1x PCGU2049
- ⑦ 1x TN100008

kg ~0,94

**triCENTRO p. 116**

25 Nm

Nach Ihren Bedürfnissen können die Micro Zentrischspanner ausgewählt werden.  
*The micro self centering vise can be selected according to your needs.*

Bestellbeispiel / Ordering example: **PS1F20L35BV1**

# Magnetspannplatte

## Magnetic chuck

PS1X150L60-250MAG11

powerCLAMP

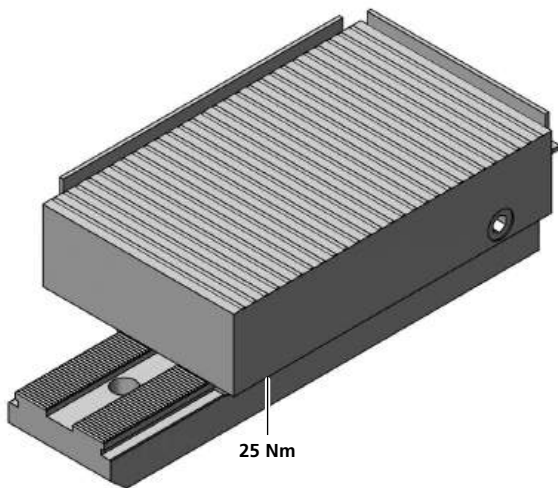
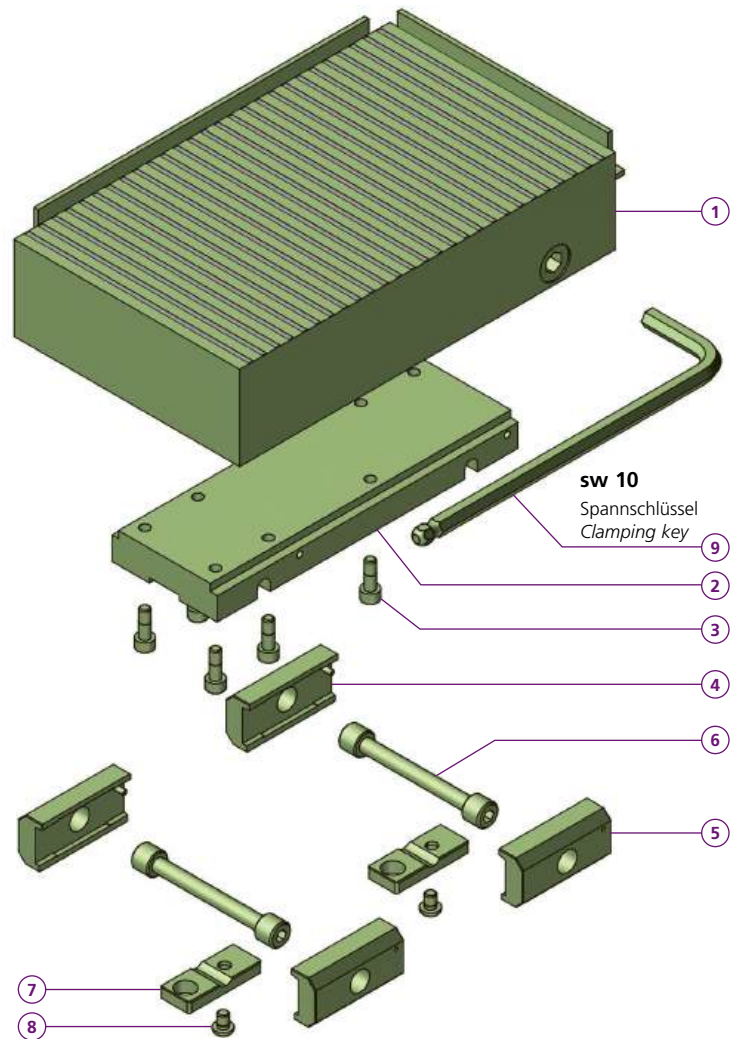
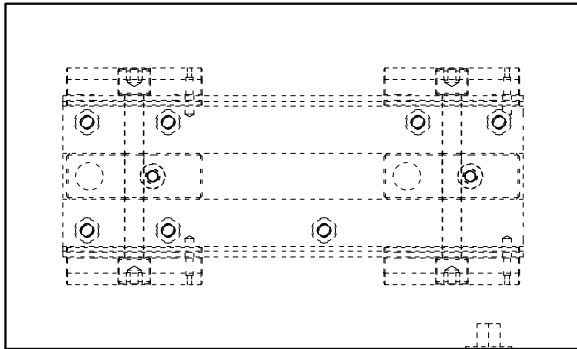
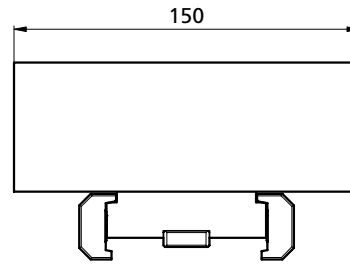
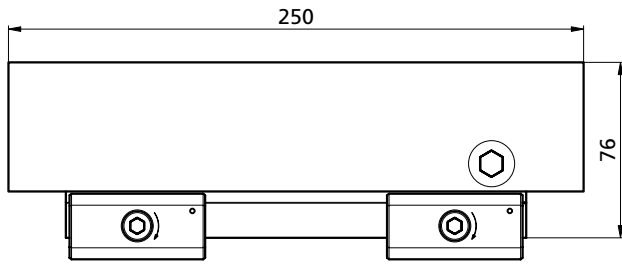

### PS1X150L60-250MAG11

- ① 1x XNeomill 250x150
- ② 1x TL110010-01
- ③ 7x MS60
- ④ 2x PCSP60L
- ⑤ 2x PCSP60R
- ⑥ 2x PCS14
- ⑦ 2x PCGU2049
- ⑧ 2x M6X8ISO7380
- ⑨ 1x ISL10 DIN 911L

kg ~19,5

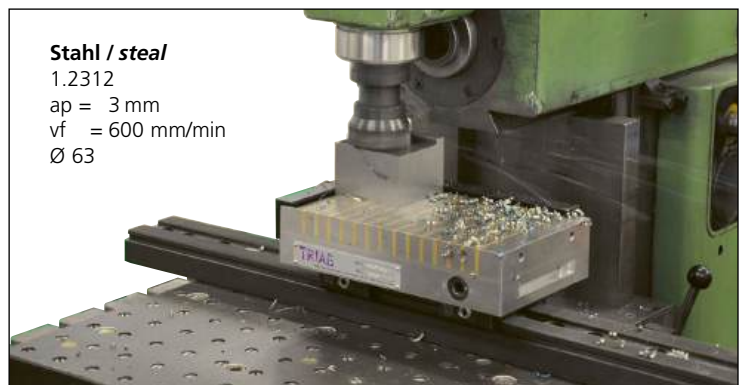

**Stahl / steel**  
 1.2312  
 ap = 3 mm  
 vf = 600 mm/min  
 Ø 63

**max. Haltekraft / max. holding force = 120 N/cm<sup>2</sup>**

- Werkstücke ab 26 mm Länge und 6 mm Stärke werden optimal gespannt
- Workpieces from 26 mm length and 6mm thickness will be optimally hold

**Bestellbeispiel / Ordering example: PS1X150L60-250MAG11**

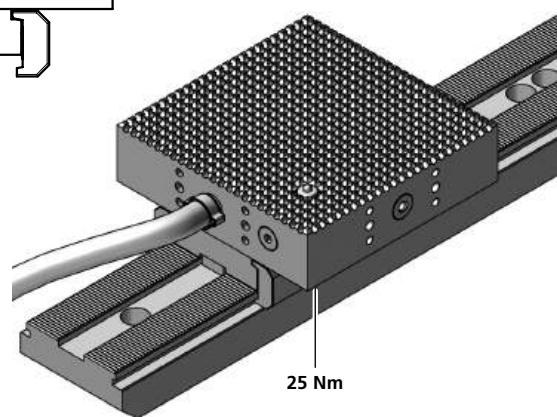
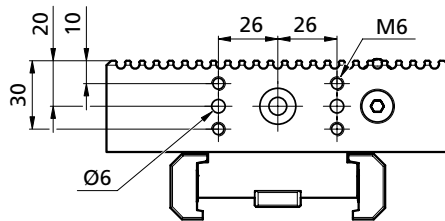
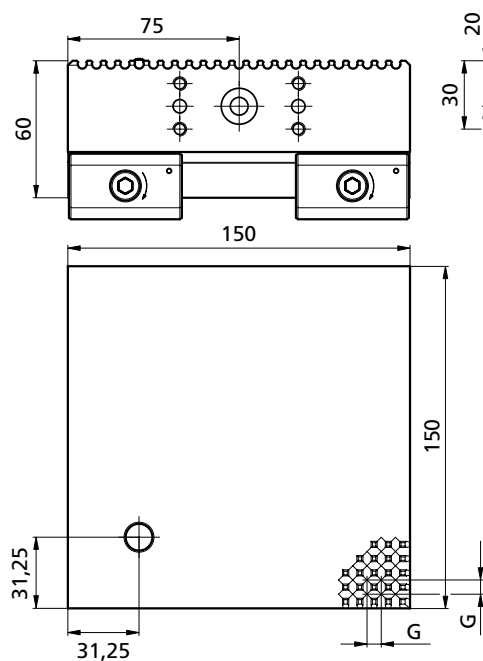

trivaCLAMP p. 318

Mehr Informationen siehe Vacuum  
For more information check the vacuum workholding

Bestellbeispiel / Ordering example: PS1X150L60-VAC



PCZ100L50

Mehr Informationen siehe Zentrischspanner  
For more information check the self centring vise p. 126 - 132

triCENTRO p. 113 - 152

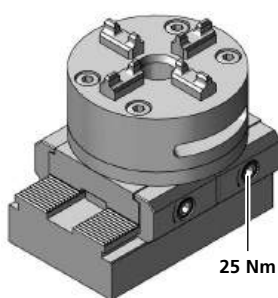
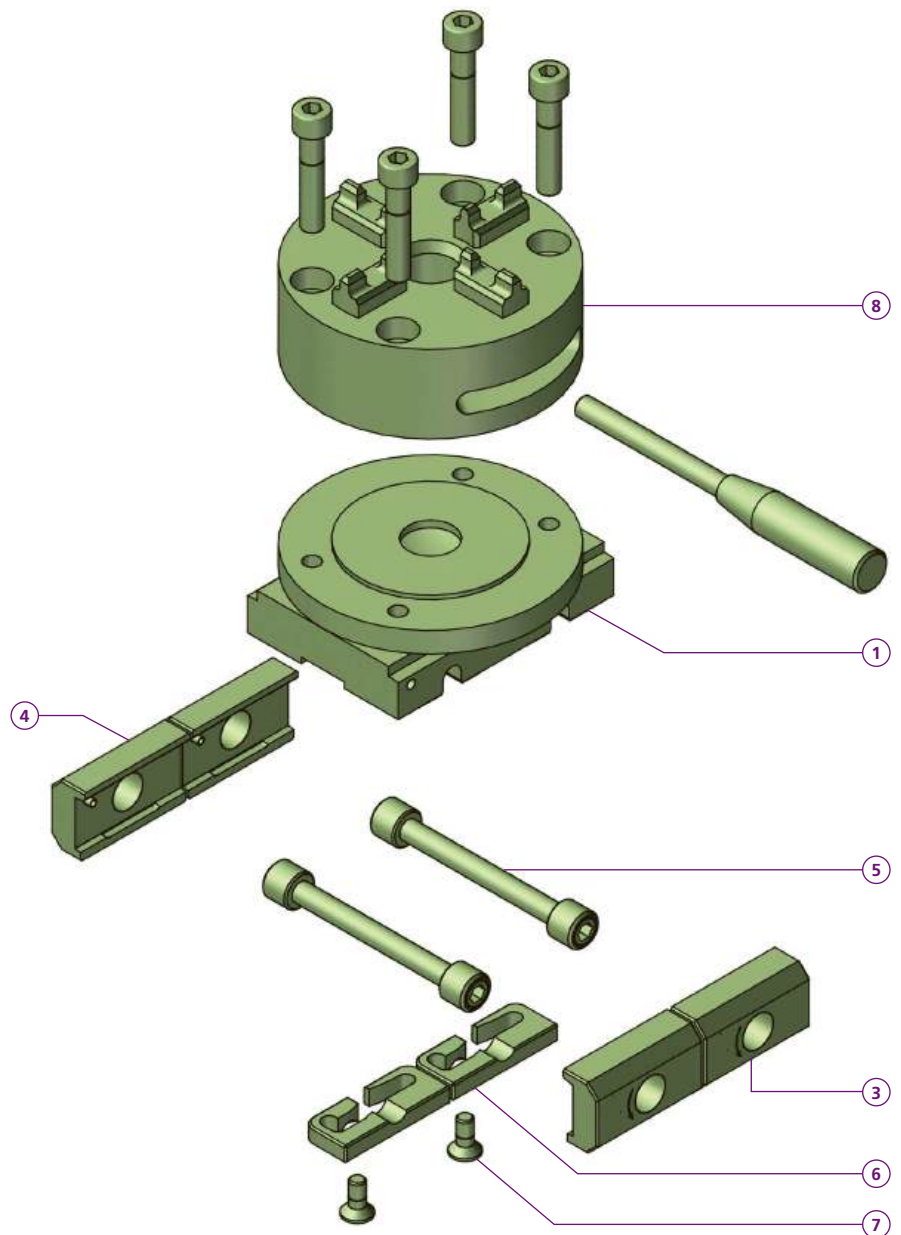
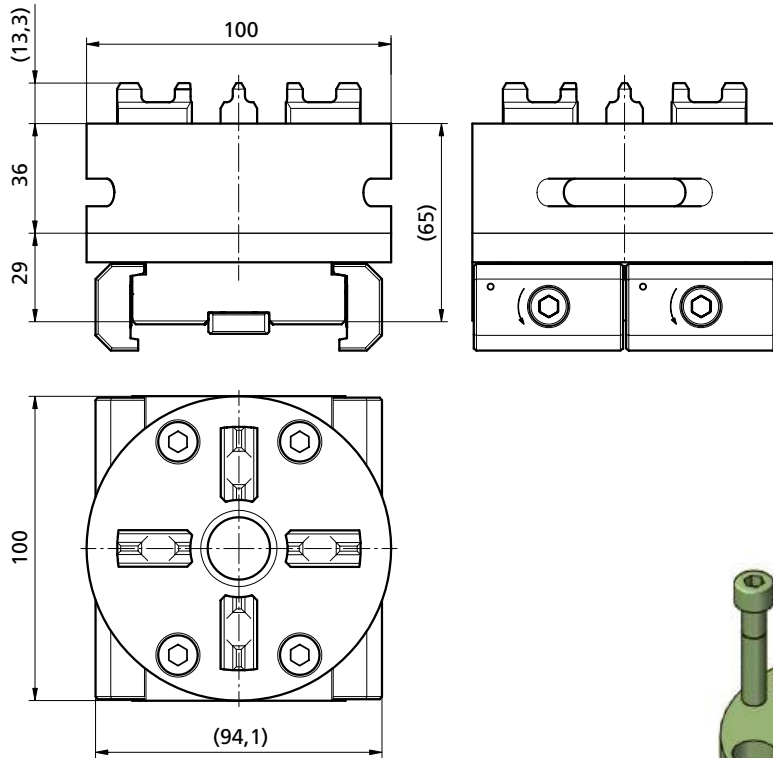

**PS1X100-65ER-036345**

- 1 1x PTX100-29
  - 3 2x PCSP50L
  - 4 2x PCSP50R
  - 5 2x PCS14
  - 6 2x PCGU2049F
  - 7 2x M6X14ISO10642
  - 8 1x ER036345
- kg ~4,0

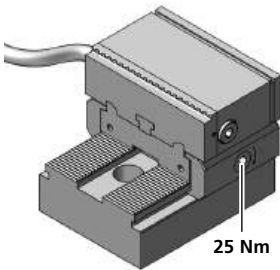
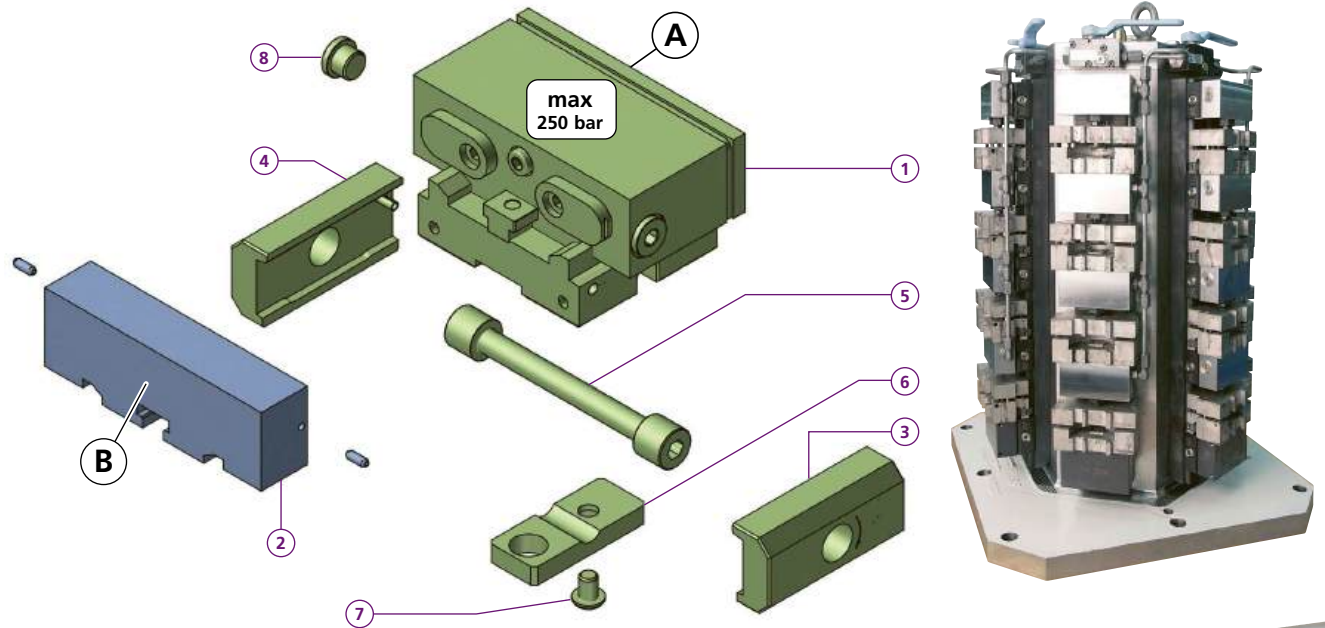
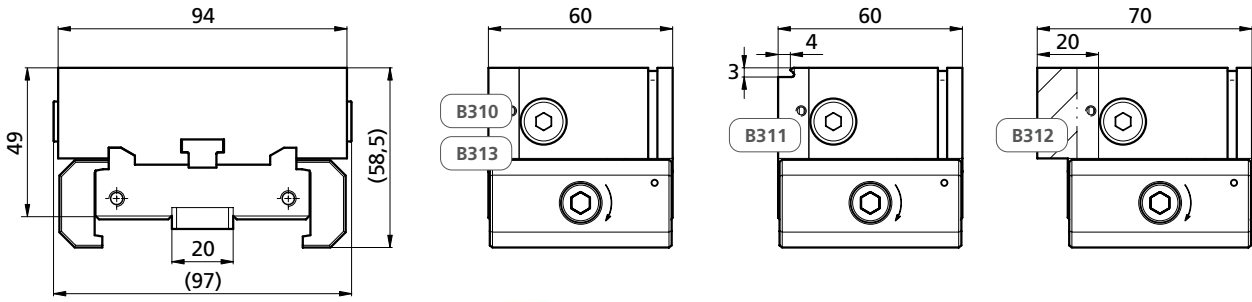

Ölvolumen / Oil volume	
Spannen / Clamping	
8 cm <sup>3</sup>	

5 mm Hub / Stroke			
bar	~daN	~(lb)	~t
100	= 960	2116	0,96
150	= 1'440	3175	1,44
200	= 1'920	4233	1,92
250	= 2'400	5291	2,4



Bestellbeispiel / Ordering example: PSH1X94L49-310 & 1 x B310

<b>B310</b>	<b>B311</b>	<b>B312</b>	<b>B313</b>	
<b>C</b>	94	94	94	94
<b>H</b>	31,5	31,5	31,5	31,5
<b>L</b>	10	10	20	10
<b>i</b>	HV700	57HRC	*	HV700
	x0,2mm			x0,2mm
<b>kg</b>	~0,18	~0,17	~0,39	~0,17

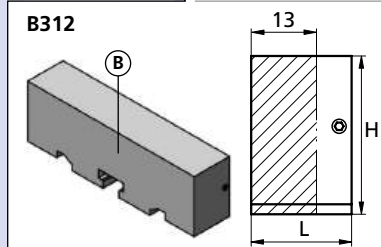
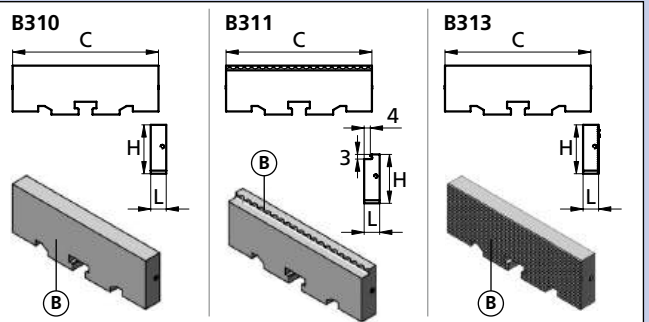

**Zum Erstellen Ihrer individuellen Formbacke:**

Schnittzeichnung zum Ermitteln der maximalen Bearbeitungsprofiltiefe

**If a dedicated jaw is being machined:**  
Sectional drawing to determine the maximum machining depth

PSH1X94L49-310

- 1 1x ZF191349
- 2 1x \_\_\_\_\_
- 3 1x PCSP60R
- 4 1x PCSP60L
- 5 1x PCS14
- 6 1x PCGU2049
- 7 1x M6X815O7380
- 8 2x TN100014
- kg ~1,94

\* = weich / soft (1.7225 Vergütungsstahl / Tempering steel)

für Hartmetalldruckstücke  
for carbide grippers

Art. Nr.	kg	Y	X
PC4349	~0,21	43	49
PC4834	~0,17	48	34
PC12549	~0,46	125	49

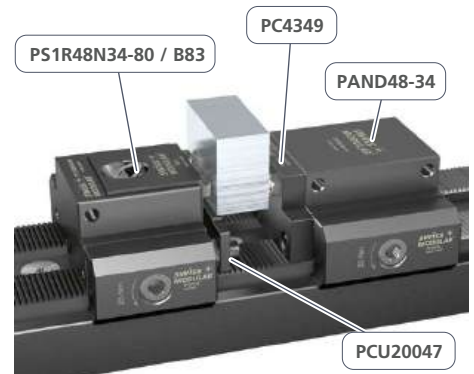
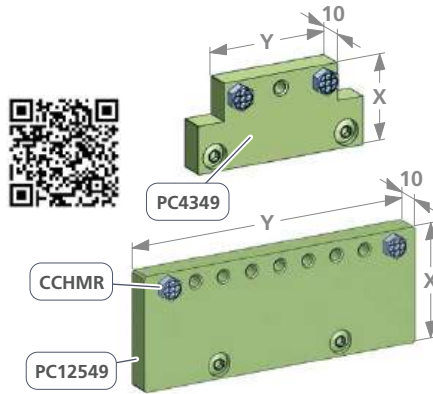

für Hartmetalldruckstücke und Fräsanschlag  
for carbide grippers and milling buffer

Art. Nr.	kg	X
PC4834RF	~0,34	34
PC4849RF	~0,44	49
PC9434RF	~0,43	34
PC9449RF	~0,63	49

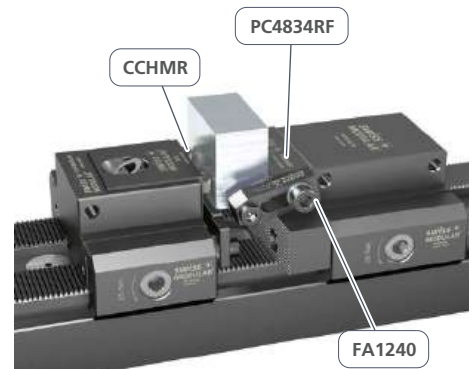
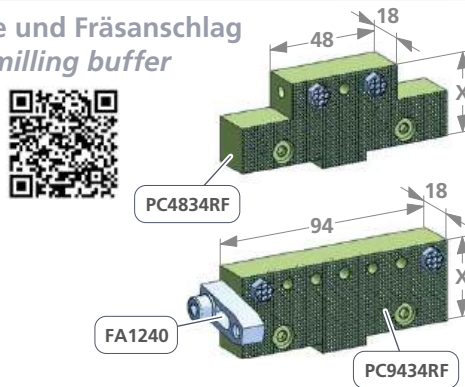

mit pendelnden Kugeldruckstücken  
with swinging ball thrust grippers

Art. Nr.	kg
PC9460	~0,45
PC9460R	~0,45

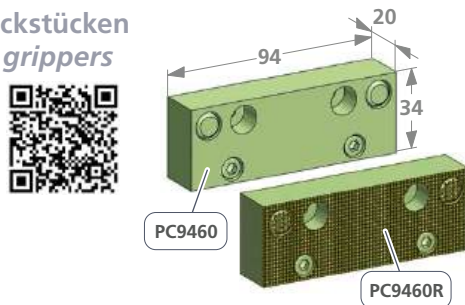

mit Prägeeinsätzen  
with embossed inserts

Art. Nr.	kg
PC9434-25PRGM8	~0,64

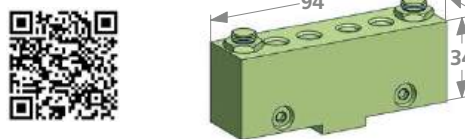

mit direkt-Prägezähnen und Spannstufen  
with direct stamping teeth and clamping steps

Art. Nr.	kg	H
PC48-34PRG	~0,18	34
PC48-49PRG	~0,24	49
PC94-34PRG	~0,25	34
PC94-49PRG	~0,48	49
PC4834-15	~0,19	34
PC4849-15	~0,24	49

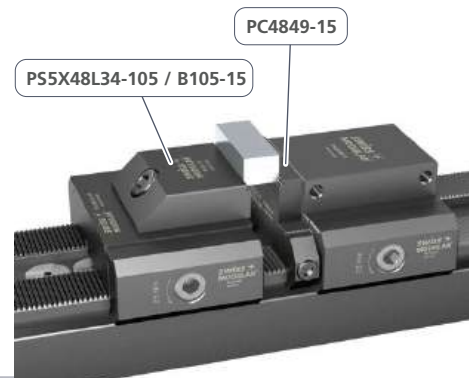
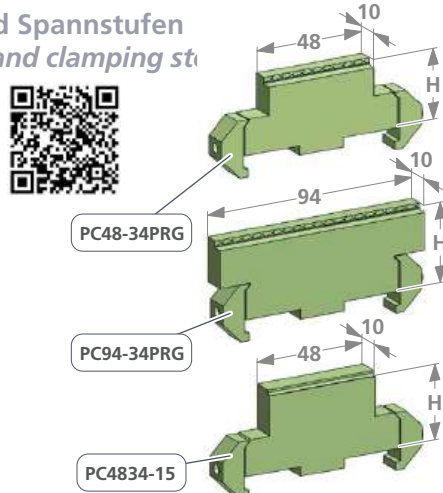

mit Druckstiften  
with pressure pins

Art. Nr.	kg	Y	X
PC4349DS	~0,22	43	49
PC4834DS	~0,17	48	34
PC4849DS	~0,23	48	49
PC9434DS	~0,27	94	34
PC9449DS	~0,38	94	49
PC12549DS	~0,49	125	49



Druckstift  
Pressure pin  
DSE0402-60°

weitere Druckstücke  
more gripping pens  
p. 337

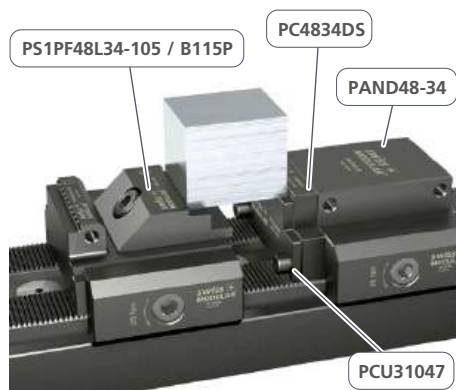
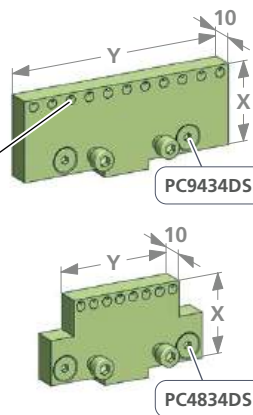

aus weichem Stahl, zur Herstellung Ihrer individuellen Backe  
made of soft steel, for the production of your individual clamping jaw

Art. Nr.	kg	Z	Y	X
PC943425W	~0,64	94	25	34
PC943430W	~0,77	94	30	34
PC944930W	~1,10	94	30	49
PC1254930W	~1,46	125	30	49

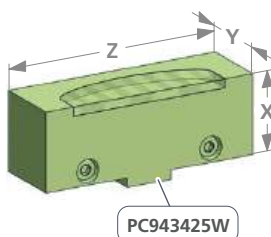

in Prismaform  
in prism form

Art. Nr.	kg	Y	X
PC9434V90-2	~0,58	28	34
PC9449V90-2	~0,58	28	49
PC9434V120	~0,62	35	34
PC9449V120	~0,89	35	49

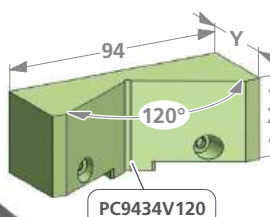
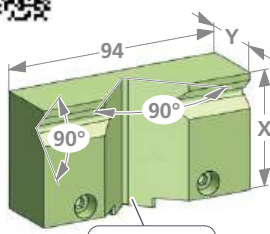

Ø  
min 5  
max 16  
Spanndurchmesser horizontal  
Clamping diameter horizontal

PC9449V90-2

PC9434V120

Ø  
min 23  
max 158  
Spanndurchmesser vertical  
Clamping diameter vertical

PC9434V120

Ø  
min 16  
max 52  
Spanndurchmesser vertical  
Clamping diameter vertical

PAND94-49

PS1F94L49-105 / B110

PCU20047

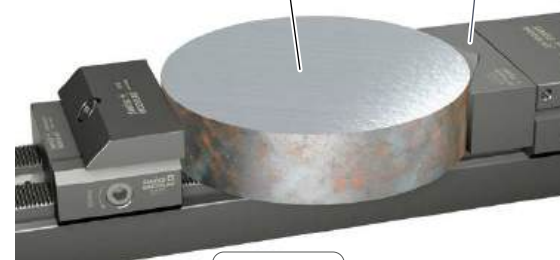
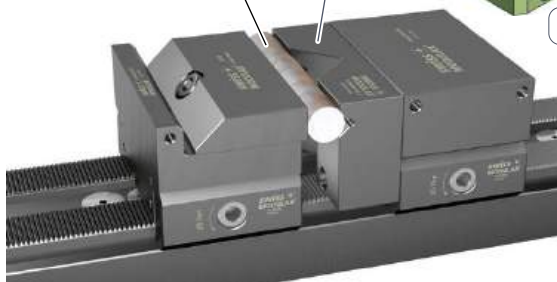

Von Niederzug zu Linear!  
From pull down jaws to linear stroke!

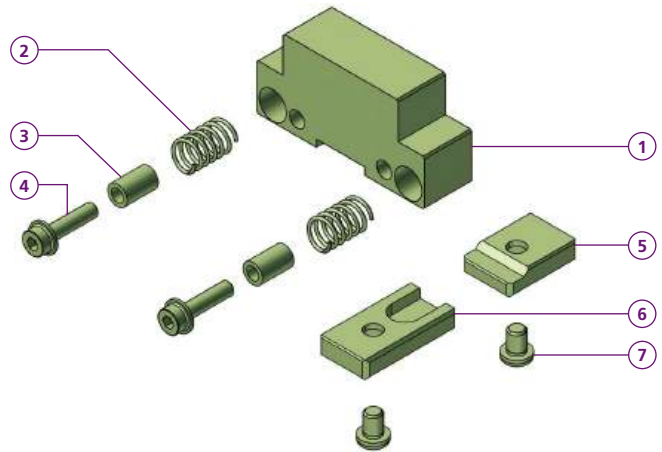
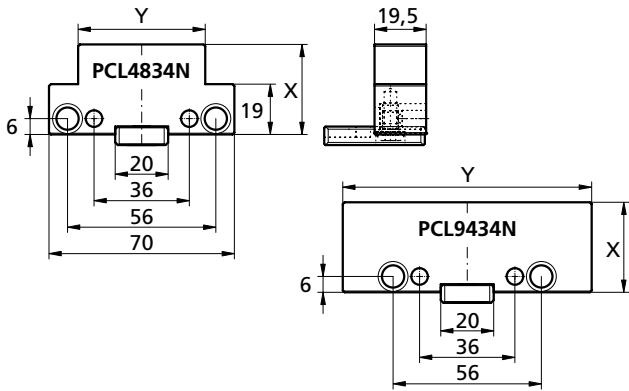

**PCL4349N**

- 1 1x TF181253
- 2 2x FED10175
- 3 2x PCD0813
- 4 2x M5X20BN1392
- 5 1x PCGU2028
- 6 1x PCGU2030LB
- 7 2x M6X8ISO7380

X = 49  
Y = 43  
kg ~0,43

Spannhub  
Clamping stroke  
0/+3,8

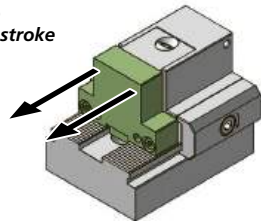

**PCL9449N**

- 1 1x TF181255

X = 49  
Y = 94  
kg ~0,74

Spannhub  
Clamping stroke  
0/+3,8

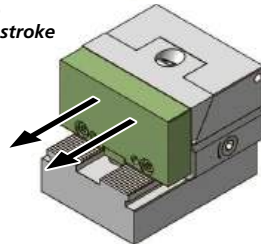

**PCL12549N**

- 1 1x TF181257

X = 49  
Y = 125  
kg ~0,97

Spannhub  
Clamping stroke  
0/+4,8

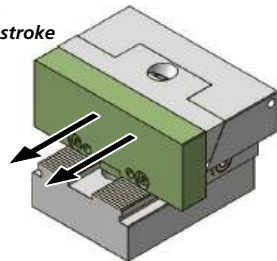

**PCL4834N**

- 1 1x TF181254
- 2 2x FED10175
- 3 2x PCD0813
- 4 2x M5X20BN1392
- 5 1x PCGU2028
- 6 1x PCGU2030LB
- 7 2x M6X8ISO7380
- 8 1x M10X22ISO4762

X = 34  
Y = 48  
kg ~0,35

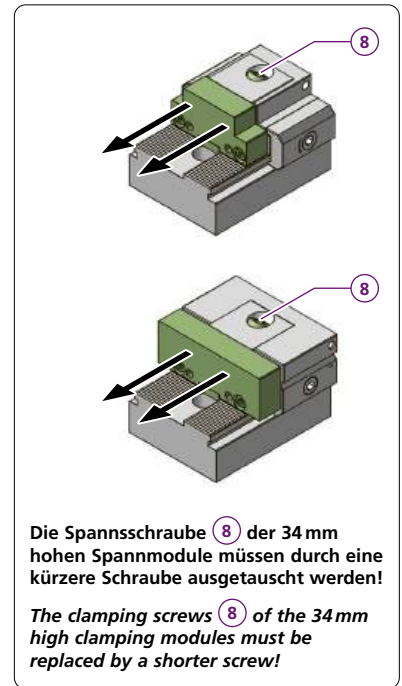

**PCL9434N**

- 1 1x TF181256

X = 34  
Y = 94  
kg ~0,52

Bestellbeispiel / Ordering example: **PCL4834N**

Montagehilfe und Ersatzteile für Linearbacken  
Assembling tool for linear jaws and spare parts

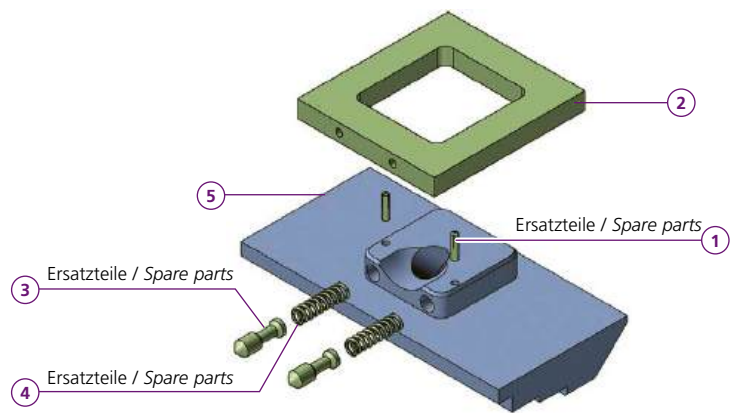
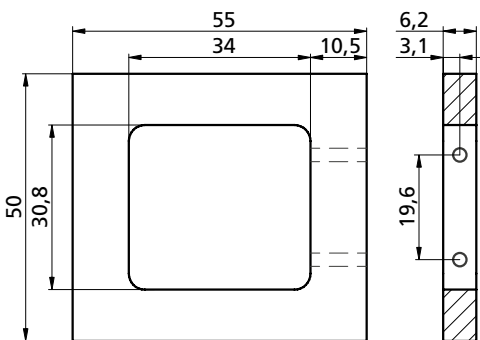

**BL-SET**

- 1 2x TN100823
- 2 1x TK160609
- 3 2x PCB0516
- 4 2x TN100614
- 5 1x \_\_\_\_\_

kg ~0,08

p. 84, 85

Alle Linearbacken  
All linear jaws

Version mit Stiften / Version with pins  
ab August / as of August 2018

Montageanleitung siehe Video  
Assembly instructions see video

Version mit Kugeln / Version with balls  
vor August / before August 2018



Separat bestellen / Order separately

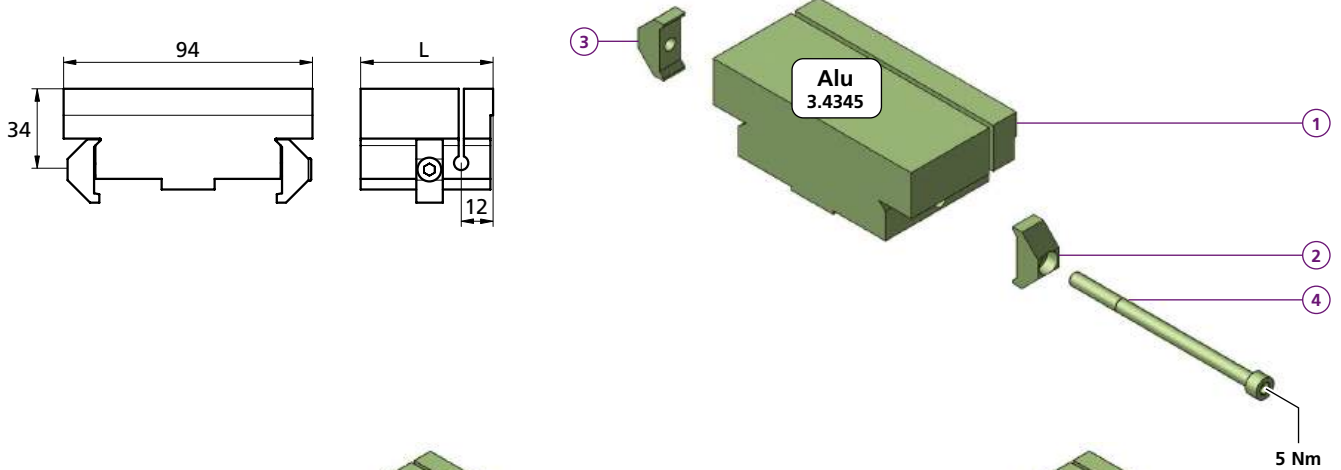

- PCFX30**
- ① 1x TF140702
  - ② 1x PCSP10B
  - ③ 1x PCSP10G
  - ④ 1x M5X85ISO4762
- L = 30  
kg ~0,27

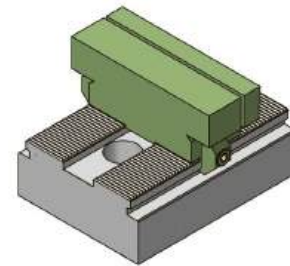
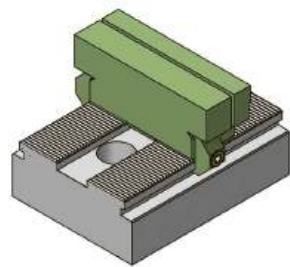

- PCFX35**
- ① 1x TF140703
- L = 35  
kg ~0,31

- PCFX50**
- ① 1x TF140704
  - ② 1x PCSP10B
  - ③ 1x PCSP10G
  - ④ 1x M5X85ISO4762
- L = 50  
kg ~0,45

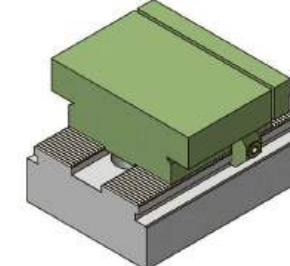
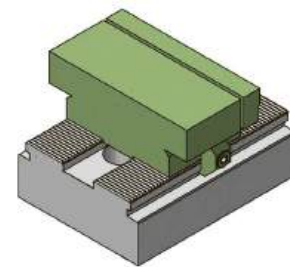

- PCFX70**
- ① 1x TF140705
- L = 70  
kg ~0,62

Auf Anfrage in Stahl erhältlich  
On request also in steel

Bestellbeispiel / Ordering example: PCFX30

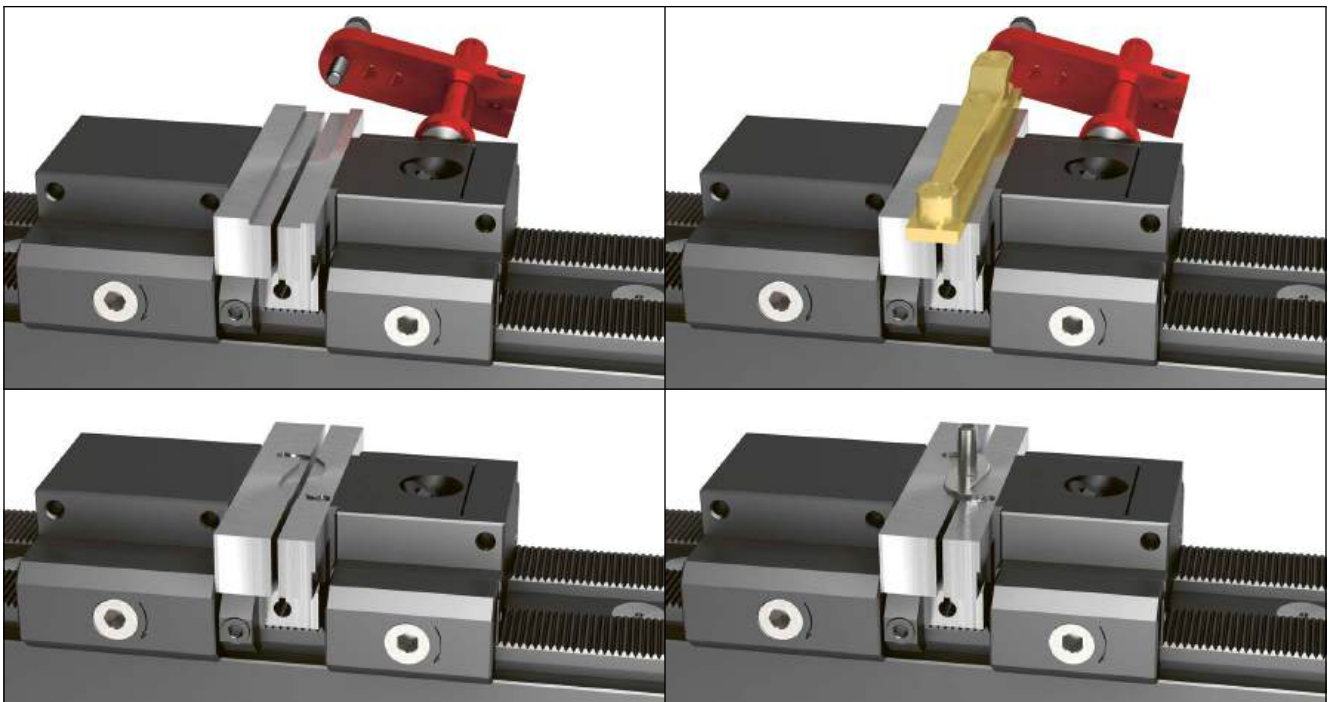

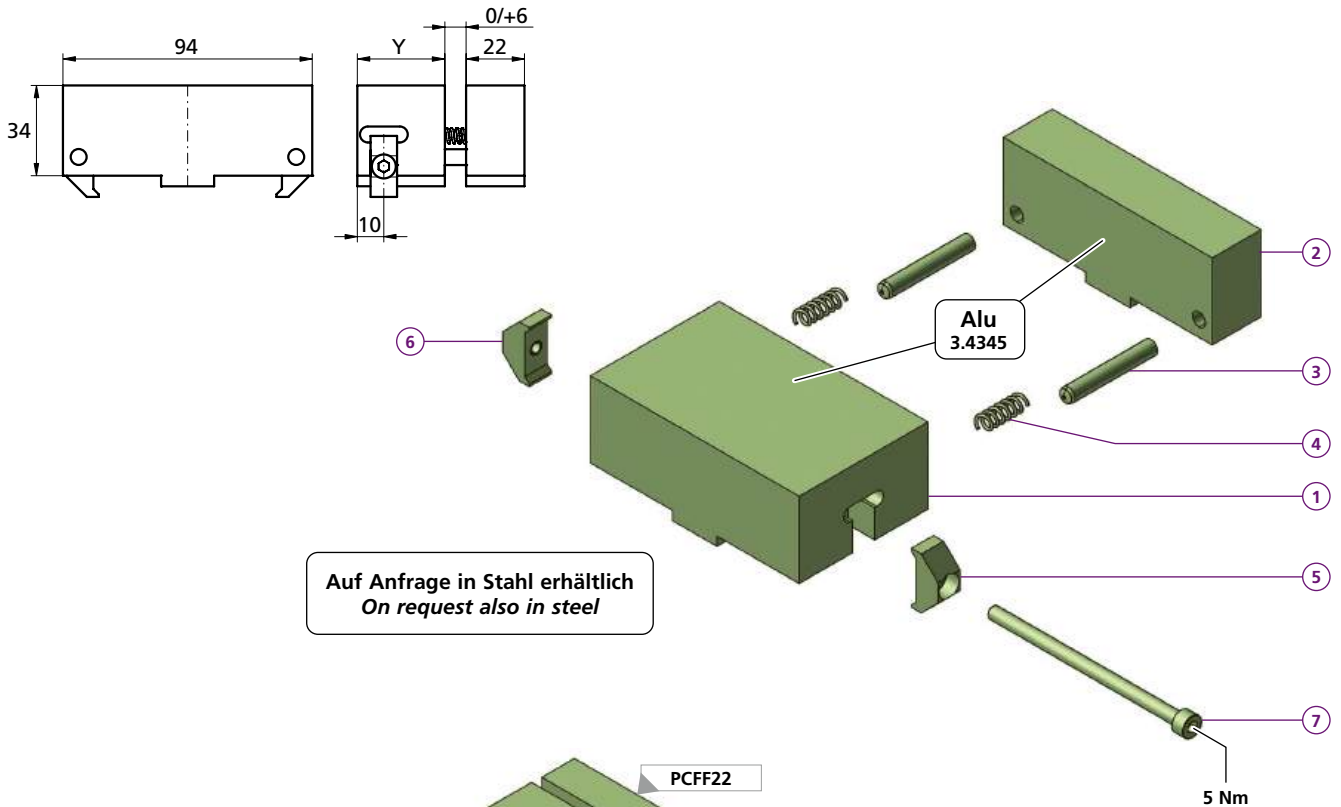

Auf Anfrage in Stahl erhältlich  
On request also in steel

**PCFM3322**

- ① 1x PCFM33
- ② 1x PCFF22
- ③ 2x CCBO0801
- ④ 2x FED0618
- ⑤ 1x PCSP10B
- ⑥ 1x PCSP10G
- ⑦ 1x M5X85ISO4762

Y = 33  
kg ~0,52

**PCFM5822**

- ① 1x PCFM58

Y = 58  
kg ~0,75

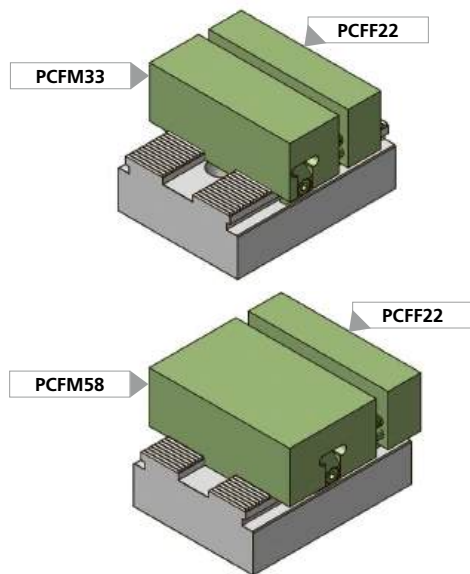

**PCSP10SET** kg ~0,04

- ① 1x PCSP10G
- ② 1x PCSP10B
- ③ 1x M5X85ISO4762

Bestellbeispiel / Ordering example: **PCFM3322**

**Anschlagbacke flach**  
**Jaw flat stop**

	B	H	kg
PCUD34093TG	93	34	~0,11
PCUD49093TG	93	49	~0,14

**Unterlagen gehärtet und geschliffen**  
**Parallels hardened and ground**

	B	H	kg
PCUD14093	93	14	~0,05
PCUD20093	93	20	~0,06
PCUD24093	93	24	~0,08
PCUD29093	93	29	~0,09
PCUD31093	93	31	~0,10
PCUD34093	93	34	~0,11
PCUD39093	93	39	~0,12
PCUD44093	93	44	~0,14
PCUD46093	93	46	~0,14
PCUD47093	93	37	~0,15

Niederzugbacken für die Anschlagseite  
Pull-down jaws for the solid reference fase

Art. Nr.	kg	H	Z
<b>PC9434NVB</b>	~0,24	49,8 – 49	10,21 – 10
<b>PC9449NVB</b>	~0,35	34,8 – 34	10,21 – 10

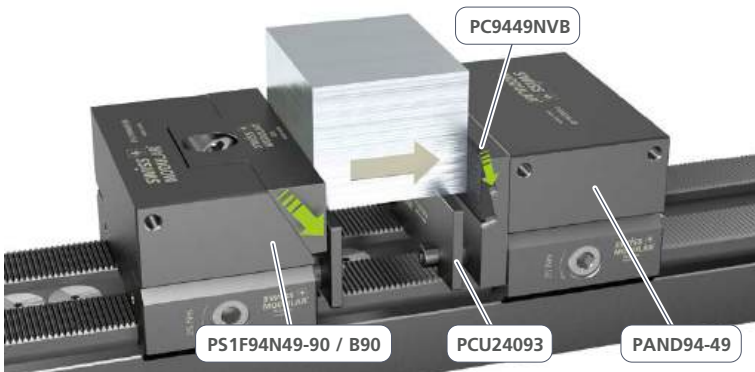
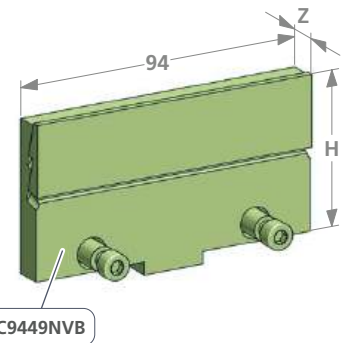

Die Niederzugbacke dient um einen zusätzlichen Niederzug-Klemmdruck auf der Anschlagseite zu erhalten.

The pull-down jaw is used to obtain an additional pull-down clamping pressure on the end module side.

Magnetische Parallelunterlagen  
Magnetic steel parallels

Art. Nr.	kg	H
<b>PCUM1409308</b>	~0,09	14
<b>PCUM2009308</b>	~0,13	20
<b>PCUM2409308</b>	~0,15	24
<b>PCUM2909308</b>	~0,18	29
<b>PCUM3109308</b>	~0,20	31
<b>PCUM3409308</b>	~0,21	34
<b>PCUM3909308</b>	~0,24	39
<b>PCUM4409308</b>	~0,27	44
<b>PCUM4609308</b>	~0,28	46

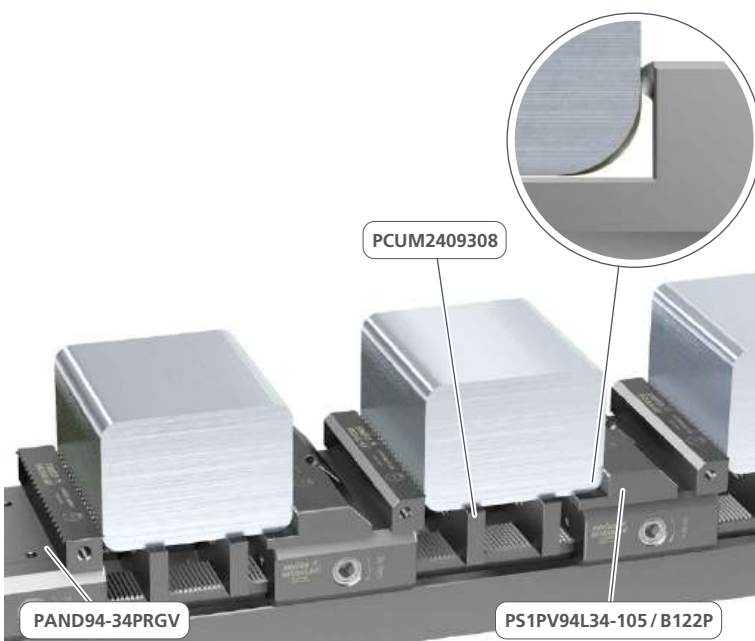
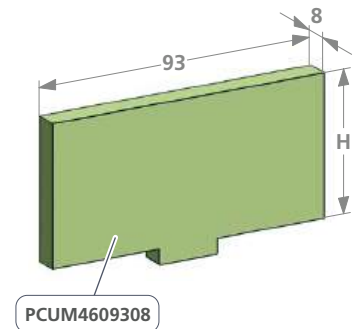

Mit diesen magnetischen Parallelunterlagen ist die Positionierung auf der Basisschiene frei wählbar. Bei Werkstücken mit grösseren Rundungen sind die Spannbacken B122P / B123P zusammen mit den Anschlagmodulen PAND94-34PRGV / PAND94-49PRGV bestens geeignet.

With these magnetic steel parallels, the positioning on the base rail is freely selectable. For workpieces with larger curves, the clamping jaws B122P / B123P together with the end modules PAND94-34PRGV / PAND94-49PRGV are best suited.

# Parallelunterlage Steel parallels

powerCLAMP

19mm	B	H	kg	34mm	B	H	kg	48mm	B	H	kg	61mm	B	H	kg	94mm	B	H	kg
PCU20018	18	20	~0,04	PCU20033	33	20	~0,04	PCU20047	47	20	~0,04	PCU20060	60	20	~0,04	PCU14093	93	14	~0,04
PCU24018	18	24	~0,04	PCU24033	33	24	~0,05	PCU24047	47	24	~0,05	PCU24060	60	24	~0,05	PCU20093	93	20	~0,06
PCU29018	18	29	~0,05	PCU29033	33	29	~0,05	PCU29047	47	29	~0,05	PCU29060	60	29	~0,06	PCU24093	93	24	~0,07
PCU31018	18	31	~0,05	PCU31033	33	31	~0,05	PCU31047	47	31	~0,05	PCU31060	60	31	~0,06	PCU29093	93	29	~0,09
PCU34018	18	34	~0,05	PCU34033	33	34	~0,06	PCU34047	47	34	~0,07				PCU31093	93	31	~0,09	
PCU39018	18	39	~0,05	PCU39033	33	39	~0,06	PCU39047	47	39	~0,07	68mm	B	H	kg	PCU34093	93	34	~0,10
PCU44018	18	44	~0,05	PCU44033	33	44	~0,07	PCU44047	47	44	~0,08	PCU20067	67	20	~0,04	PCU39093	93	39	~0,11
PCU46518	18	46,5	~0,06	PCU46033	33	46	~0,06	PCU46047	47	46	~0,08	PCU24067	67	24	~0,05	PCU44093	93	44	~0,12
				PCU46533	33	46,5	~0,07				PCU29067	67	29	~0,06	PCU46093	93	46	~0,14	
											PCU31067	67	31	~0,07	PCU47093	93	47	~0,14	
26mm	B	H	kg	43mm	B	H	kg	58mm	B	H	kg								
PCU20025	25	20	~0,04	PCU20042	42	20	~0,04	PCU20057	57	20	~0,04								
PCU24025	25	24	~0,05	PCU24042	42	24	~0,05	PCU24057	57	24	~0,05	78mm	B	H	kg	125mm	B	H	kg
PCU29025	25	29	~0,05	PCU29042	42	29	~0,05	PCU29057	57	29	~0,06	PCU20077	77	20	~0,05	PCU20124	124	20	~0,08
PCU31025	25	31	~0,05	PCU31042	42	31	~0,06	PCU31057	57	31	~0,06	PCU24077	77	24	~0,06	PCU24124	124	24	~0,09
PCU34025	25	34	~0,05	PCU34042	42	34	~0,06				PCU29077	77	29	~0,07	PCU29124	124	29	~0,11	
PCU39025	25	39	~0,06	PCU39042	42	39	~0,07				PCU31077	77	31	~0,08	PCU31124	124	31	~0,12	
PCU44025	25	44	~0,06	PCU44042	42	44	~0,07				PCU34077	77	34	~0,08	PCU34124	124	34	~0,13	
PCU46525	25	46,5	~0,06	PCU46042	42	46	~0,08				PCU39077	77	39	~0,09	PCU39124	124	39	~0,15	
				PCU47042	42	47	~0,08				PCU44077	77	44	~0,11	PCU44124	124	44	~0,17	
														PCU46124	124	46	~0,18		

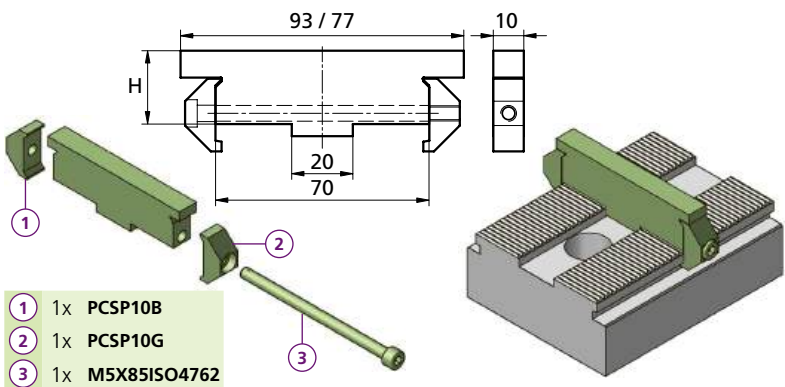
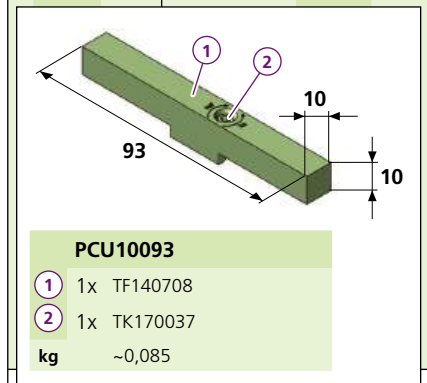
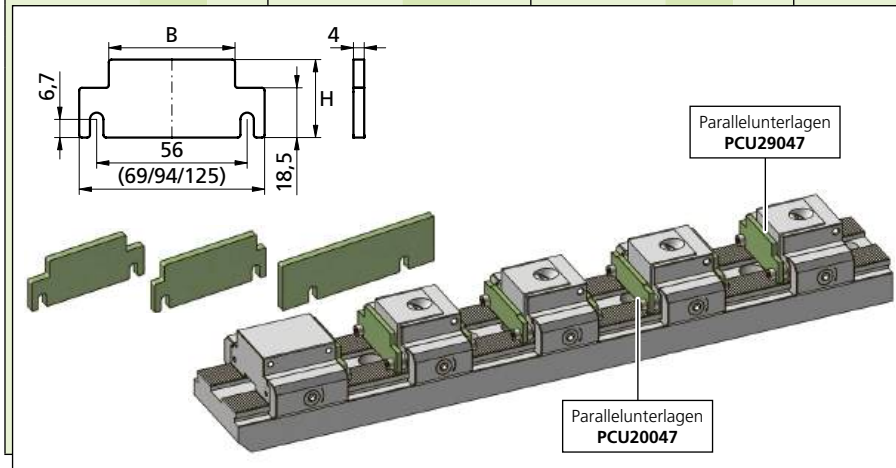

weich / soft	1.7225	hart / hardened	HV700 x0,2mm		
H= +0,15 +0,25	H	H	H		
	kg	H= ± 0,005	kg		
PCU20077B10-W	20	~0,15	PCU20077B10	20	~0,15
PCU24093B10-W	24	~0,19	PCU24093B10	24	~0,19
PCU39093B10-W	39	~0,29	PCU29093B10	29	~0,23
PCU44093B10-W	44	~0,33	PCU31093B10	31	~0,24
PCU46093B10-W	46	~0,34	PCU34093B10	34	~0,27
			PCU39093B10	39	~0,29
			PCU44093B10	44	~0,33
			PCU46093B10	46	~0,34

## Unterlagen- und Fränschlaghalter Holder for parallels and workpiece stop

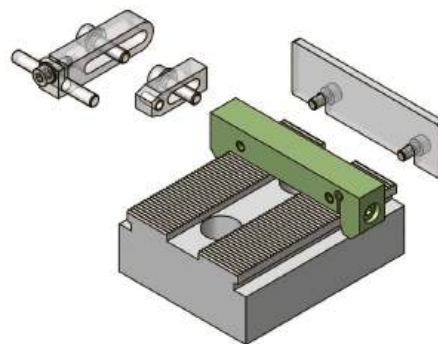
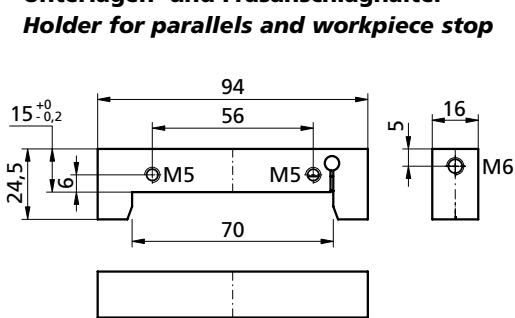

PCUH2594	
1	1x TF140706
2	2x M5X8ISO4762
3	1x M5X22ISO4762
kg	~0,19

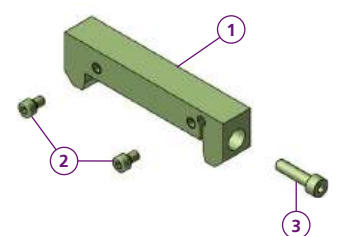

Bestellbeispiel / Ordering example: **PCUH2594**



**triCENTRO**

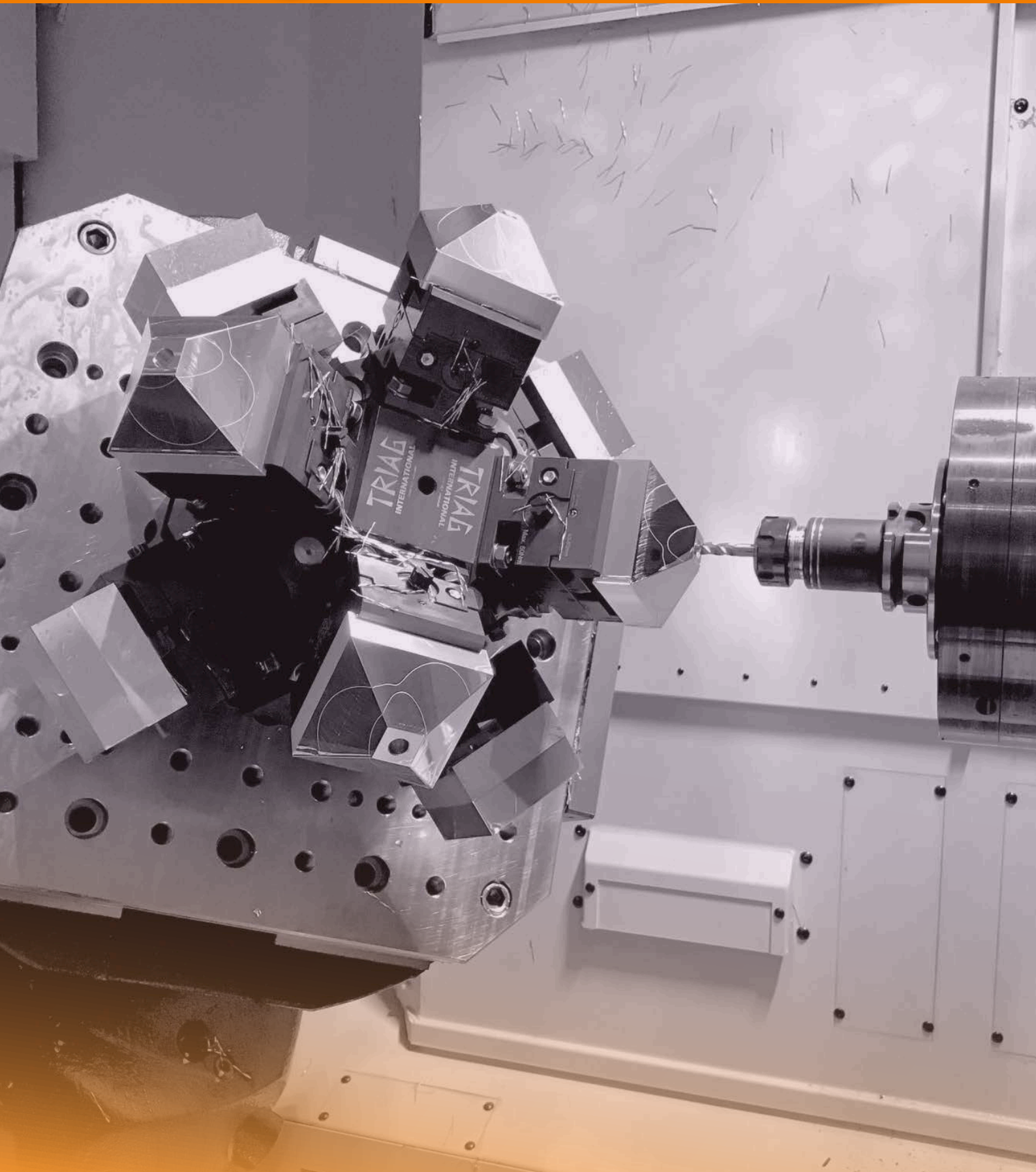



Einleitung und Anwendungsbeispiele | *Introduction and examples of application* ..... 115

Micro - Zentrierspanner | *Micro - self centering vise* ..... 116 - 117

5-Achs Pyramidenlösungen  
5-axis pyramid solutions 35° ..... 118

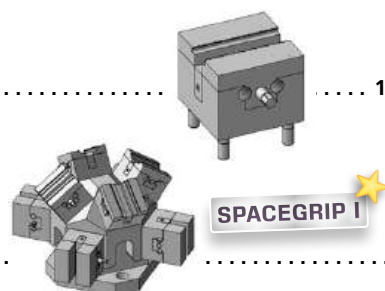

5-Achs Pyramidenlösungen  
5-axis pyramid solutions 45° ..... 119



5-Achs Pyramidenlösungen  
5-axis pyramid solutions 20° ..... 122



Kompakter Zentrischspanner | *Compact self centering vise* ..... 123 - 124

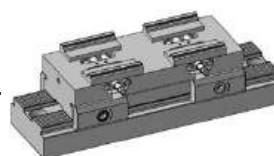

Mini Zentrierspanner | *Mini - self centering vise* ..... 126 - 129

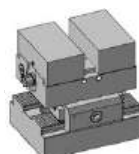

Zentrischspanner mit Anschlagbrücke  
Self centering vise with center stop ..... 130 - 131



Mini Zentrischspanner / Spannvielfalt der Backen | *Mini - self centering vise / Clamping variety of jaws* ..... 132

5-Achs Pyramidenlösungen  
5-axis pyramid solutions 45° / 90° ..... 133

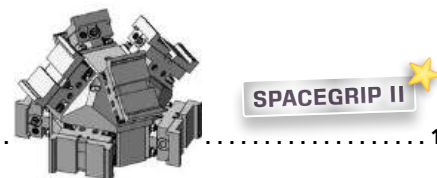

5-Achs Pyramidenlösungen  
5-axis pyramid solutions 45° ..... 136

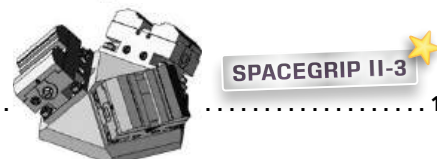



Zentrischspanner X M Q Serien  
Self centering vises X M Q series ..... 137 - 149

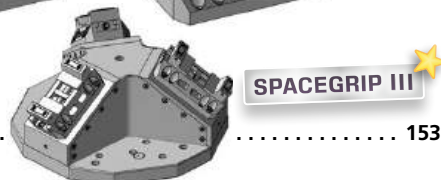

5-Achs Pyramidenlösungen  
5-axis pyramid solutions 35°-3 ..... 153 - 154

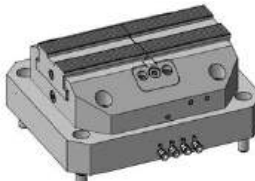

<b>ZSP Micro - Zentrischspanner</b> <b>ZSP Micro - self centering vise</b> .....		..... 156
<b>ZSP125 Mini - Pneumatischer Zentrischspanner (einfacher Kolben)</b> <b>ZSP125 Mini - Pneumatic self centering vise (single piston)</b> .....		..... 157
<b>ZSP125 Mini - Pneumatischer Zentrischspanner (Doppelkolben)</b> <b>ZSP125 Mini - Pneumatic self centering vise (Double piston)</b> .....		..... 158
<b>ZSP Grande - Pneumatischer Zentrierspanner</b> <b>ZSP Grande - Pneumatic self centering vise</b> .....		..... 160 - 161

**Triag International AG** bietet ein breites Sortiment an Zentrischspannern an. Neben den Zentrischspannern, die auf die Schienensysteme Power Clamp das Nullpunktsystem oppSystem passen, sind auch Ausführungen für Lochraster erhältlich.

Mit unseren modularen Zentrischspannblöcken bieten wir eine optimale Lösung für die Mehrfachspannung in Ihrer 5-Achs Fräsmaschine an. Für alle Zentrischspanner sind verschiedene Aufsatz- und Prägebacken erhältlich.

*Triag International AG offers a wide range of self centering vices. In addition to the self centering vice that fit into the rail systems Power Clamp the zero point system oppSystem, mechanical self centering vice are also available.*

*With our modular self centric vice blocks we offer an optimal solution for multiple workholding in your 5-axis milling machine. Different jaws and stamping jaws are available for all self centering vices.*

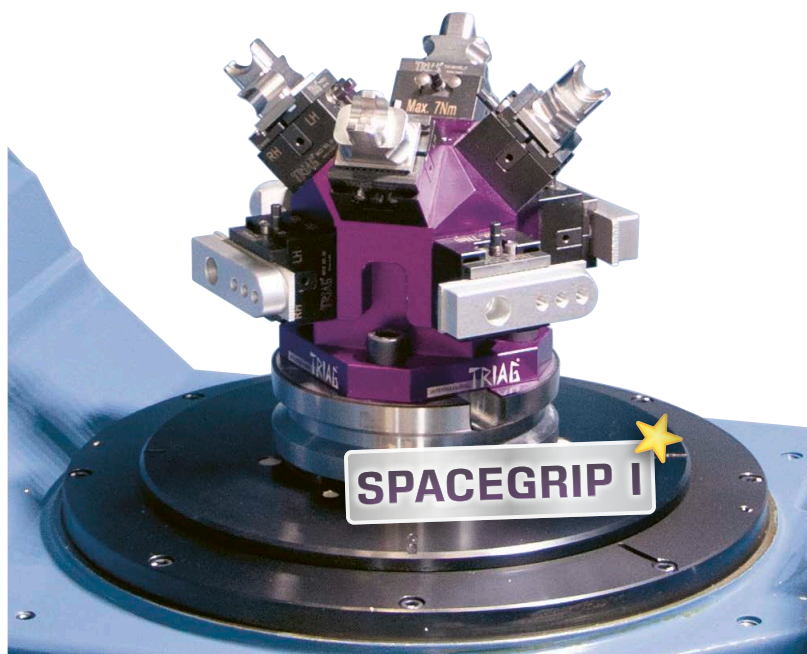

Für den Vorrichtungsbau  
For dedicated fixtures

Art. Nr.			A mm	kg
<b>MCZ40L30PRG13</b>			3 – 13	~0,34
<b>MCZ40L30PRG22</b>			12 – 22	~0,33
<b>MCZ40L30PRG31</b>			21 – 31	~0,32
<b>MCZ40L30W6</b>			weicher Stahl soft steel (1.7225)	variabel ~0,33
<b>MCZ40L30W10</b>			weicher Stahl soft steel (1.7225)	variabel ~0,37
<b>MCZ40L30W20</b>			weicher Stahl soft steel (1.7225)	variabel ~0,47
<b>MCZ40L30W30</b>			weicher Stahl soft steel (1.7225)	variabel ~0,57

### NUSS 1/4" 4.5MM

#### WICHTIG!

Bitte separat bestellen

#### IMPORTANT!

Please order separately

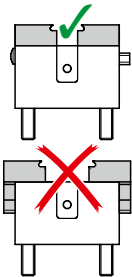

#### ACHTUNG / CAUTION

Die Angaben der Spannereiche bei den verschiedenen Backen sind unbedingt zu beachten und einzuhalten! Bei unsachgemäßer Anwendung übernimmt TRIAG International keine Haftung.

The details of the clamping ranges for the different jaws must be strictly followed! In case of improper use, TRIAG International assumes no liability.

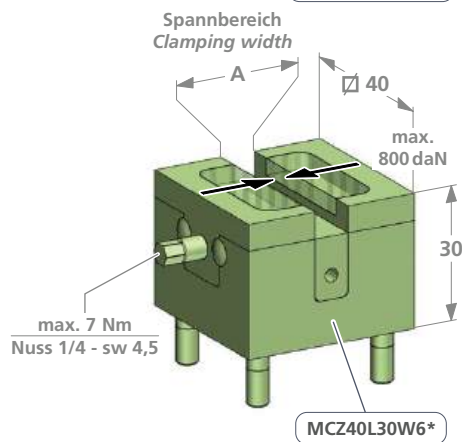
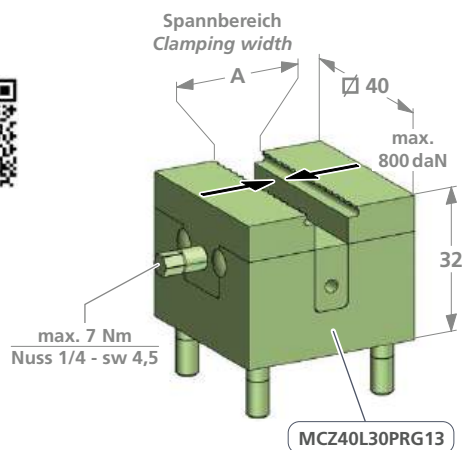

z.B. Fränschlag / f.e. Milling buffer

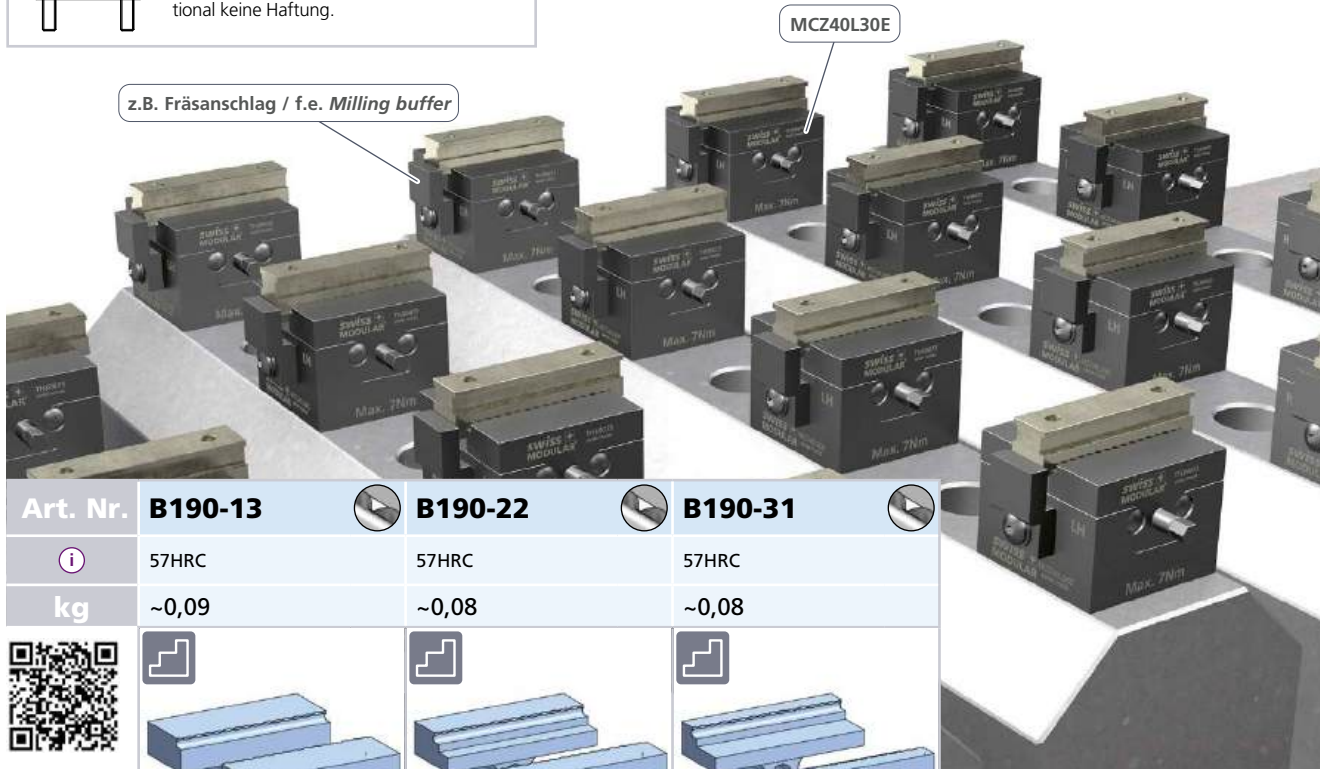

Art. Nr.	<b>B190-13</b>	<b>B190-22</b>	<b>B190-31</b>

Für den Vorrichtungsbau / Mit einstellbarem Mittellager  
For dedicated fixtures / With adjustable center position

Art. Nr.	Backen Jaws	A mm	kg
<b>MCZ40L30E</b>	<b>B190-13</b>	3 – 13	~0,24
	<b>B190-22</b>	12 – 22	
	<b>B190-31</b>	21 – 31	
	<b>B190W6-40</b>	variabel	
	<b>B190W10-40</b>	variabel	
	<b>B190W20-40</b>	variabel	
	<b>B190W30-40</b>	variabel	

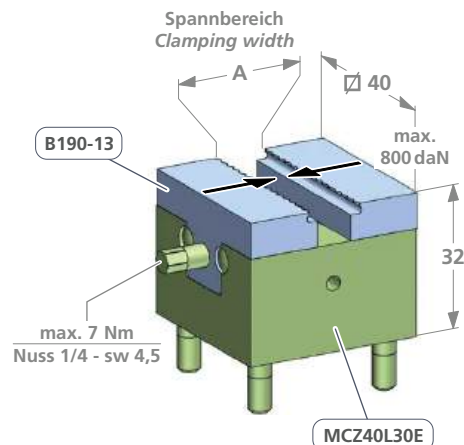

Das Zentrum kann durch das Mittellager um +/- 0,5 mm  
verstellt werden. Eine schwimmende  
Werkstückspannung ist auch möglich.

**Lieferzustand:**

Zentriert mit einer Toleranz von +/- 0,03 mm

The center can be adjusted by +/- 0,5 mm through the center  
support. A floating fixture is also possible.

**Delivery condition:**

Centered with a tolerance of +/- 0,03 mm

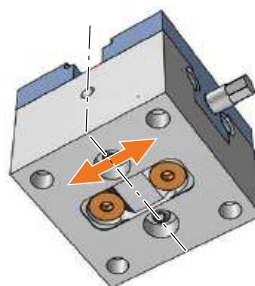

**Bedienungsanleitung  
Operating instruction**



Ohne einstellbares Mittellager  
Without adjustable center position

Art. Nr.	Backen Jaws	A mm	kg
<b>MCZ40L30</b>	<b>B190-13</b>	3 – 13	~0,24
	<b>B190-22</b>	12 – 22	
	<b>B190-31</b>	21 – 31	
	<b>B190W6-40</b>	variabel	
	<b>B190W10-40</b>	variabel	
	<b>B190W20-40</b>	variabel	
	<b>B190W30-40</b>	variabel	

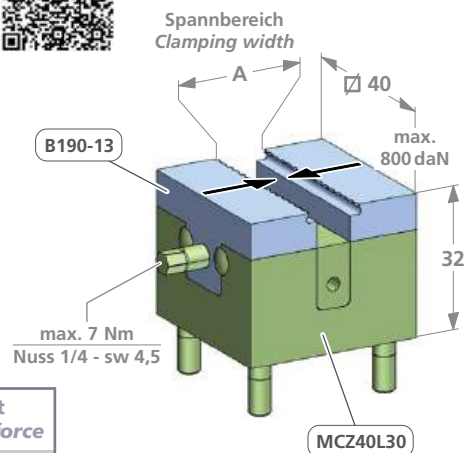

Drehmoment Torque		Spannkraft Workholding force		
Nm	(lb-ft)	~daN	~(lb)	~t
4	3	= 457	1'007	0,46
5	3,7	= 571	1'259	0,57
6	4,4	= 686	1'512	0,69
7	5,2	= 800	1'764	0,8

<b>B190W6-40</b>	<b>B190W10-40</b>	<b>B190W20-40</b>	<b>B190W30-40</b>
weicher Stahl soft steel (1.7225)	weicher Stahl soft steel (1.7225)	weicher Stahl soft steel (1.7225)	weicher Stahl soft steel (1.7225)
~0,08	~0,012	~0,22	~0,32

Weich, zur Herstellung individueller Formbacke. / Soft, for the production of individual moulding jaw.



**SEPARAT BESTELLEN  
ORDER SEPARATELY**

spaceGRIP I

Die spaceGRIP Baureihe wurde speziell für die effizientere Nutzung von 5-Achsen Maschinen entwickelt. Dabei zeichnen sich alle drei Baureihen der spaceGRIP Serie mit unterschiedlichen Merkmalen aus.

Sehr kompakte Bauweise zur Aufnahme von 4 oder 8 Micro Zentrischspannmodulen. Für die Rohteilebearbeitung gibt es drei Bausätze Prägebacken (3–13 mm, 12–22 mm und 21–31 mm).

Für die zweite Spannung gibt es vier Sätze unterschiedlicher Backenrohlinge für die Einarbeitung einer Kontur. Die Spannkraft liegt bei 7 Nm 0,8t 800 daN.

spaceGRIP I

The spaceGRIP series was specially developed to improve the out puts of 5-axis machines. All three types of the spaceGRIP series have different features.

Very compact design to hold 4 or 8 micro self centering clamping modules. There are three assembly kits of stamping jaws (3–13 mm, 12–22 mm and 21–31 mm) for raw part machining.

For the second clamping, there are four sets of different jaw blanks to integrate any shapes. The clamping force is at 7 Nm 0.8t 800 daN.

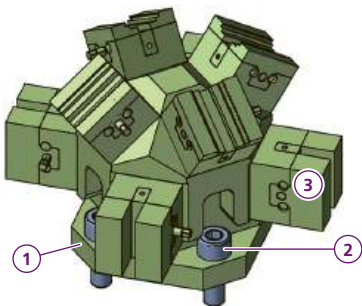
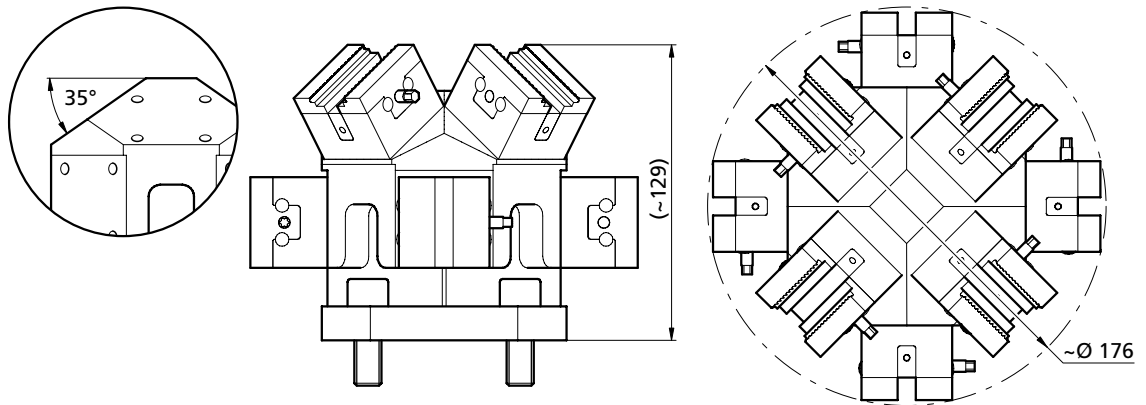

	<b>UB5AXMCZ4035SET8</b>		Detailzeichnung zu dieser Schnittstelle Detail drawing to interface
1	1x TB170676		
2	4x M12X35ISO4762		
3	8x Ihre Wahl / Your choice		p. 116 - 117
kg	~5,1		

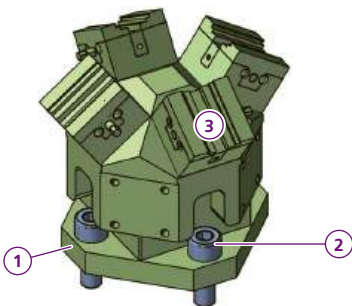

	<b>UB5AXMCZ4035SET4</b>		Detailzeichnung zu dieser Schnittstelle Detail drawing to interface
1	1x TB170676		
2	4x M12X35ISO4762		
3	4x Ihre Wahl / Your choice		p. 116 - 117
kg	~3,2		

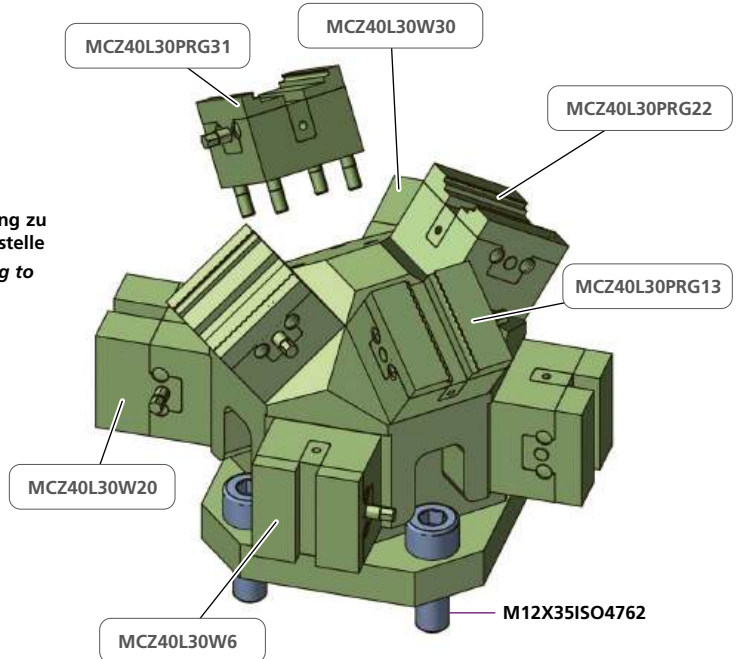

**NUSS 1/4" 4.5MM**

**WICHTIG!**  
Bitte separat bestellen  
**IMPORTANT!**  
Please order separately



Bestellbeispiel / Ordering example:  
2 x UB5AXMCZ40-35SET8 & 8 x MCZ40L30W10 &  
8 x MCZ40L30PRG22 & 1 x Nuss 1/4 - sw 4,5

Separat bestellen / Order separately

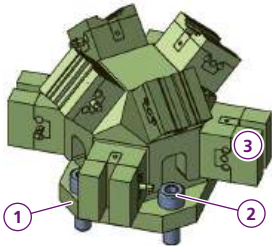

- UB5AXMCZ40-45SET8**
- 1x TK140867
  - 4x M12X35ISO4762
  - 8x Ihre Wahl/ Your choice
- kg ~5,2



Detailzeichnung zu dieser Schnittstelle  
Detail drawing to interface

p. 116 - 117

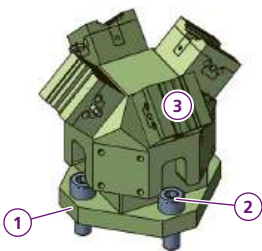
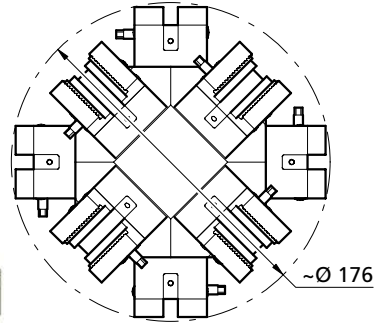
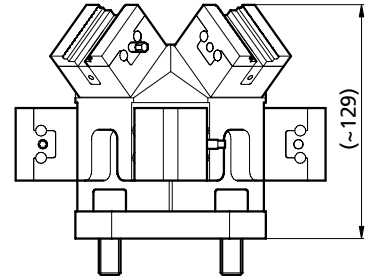
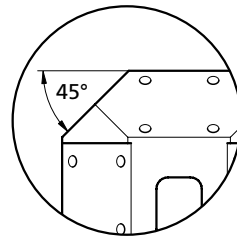

- UB5AXMCZ4045SET4**
- 1x TK140867
  - 4x M12X35ISO4762
  - 4x Ihre Wahl/ Your choice
- kg ~4,2



Detailzeichnung zu dieser Schnittstelle  
Detail drawing to interface

p. 116 - 117

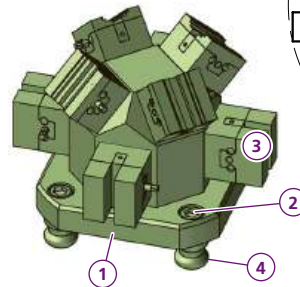

- UB5AXMCZ4045SET8-OPBM**
- 1x TK160869
  - 4x M12X20ISO4762
  - 8x Ihre Wahl/ Your choice
  - 4x OPBM18M12
- kg ~6,2



Detailzeichnung zu dieser Schnittstelle  
Detail drawing to interface

p. 116 - 117

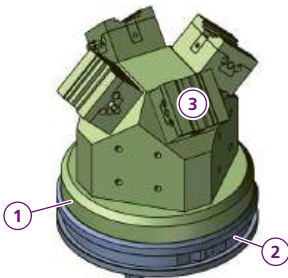

- UB5AXMCZ4045SET4-ER**
- 1x TB161062
  - 1x ER-129663 EROWA ITS-Palette
  - 4x Ihre Wahl/ Your choice
- kg ~4,1



Detailzeichnung zu dieser Schnittstelle  
Detail drawing to interface

p. 116 - 117

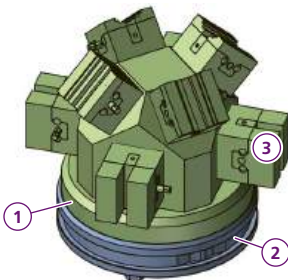

- UB5AXMCZ40-45SET8-ER**
- 1x TB161062
  - 1x ER-129663 EROWA ITS-Palette
  - 8x Ihre Wahl/ Your choice
- kg ~6,1



Detailzeichnung zu dieser Schnittstelle  
Detail drawing to interface

p. 116 - 117

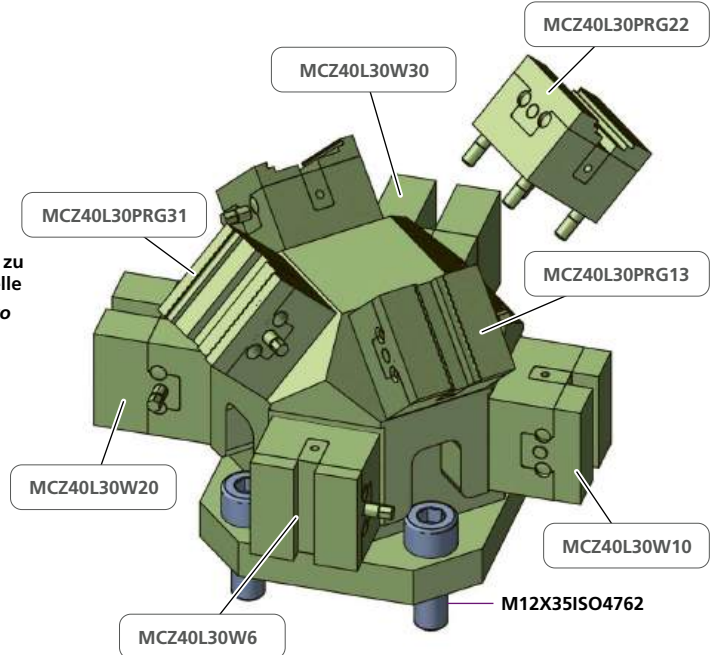

**NUSS 1/4" 4.5MM**

**WICHTIG!**  
Bitte separat bestellen  
**IMPORTANT!**  
Please order separately



Bestellbeispiel / Ordering example:  
2 x UB5AXMCZ40-45SET8 & 8 x MCZ40L30W20 &  
8 x MCZ40L30PRG22 & 1 x Nuss 1/4 - sw 4,5

Separat bestellen / Order separately

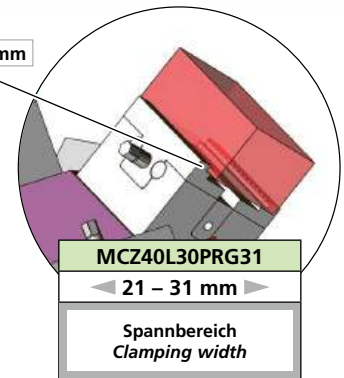
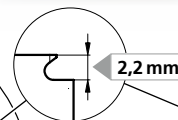
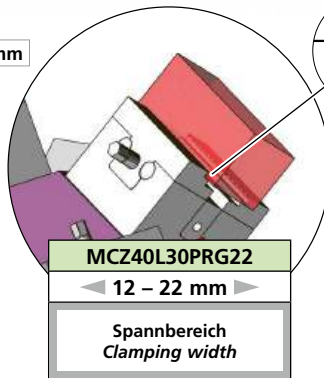
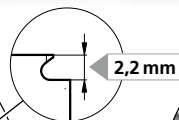
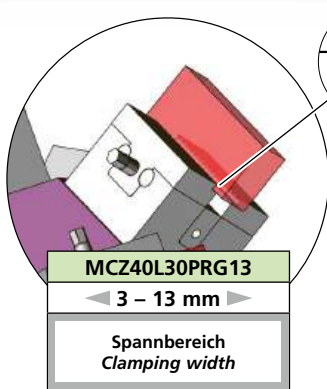

p. 116 Micro Zentrischspanner / Micro - self centering vise

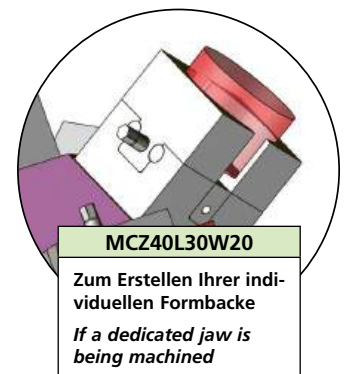

p. 116 Micro Zentrischspanner / Micro - self centering vise

Anwendungsbilder  
Pictures of application to

**MICRO**

Zentrischspanner  
self centering vise

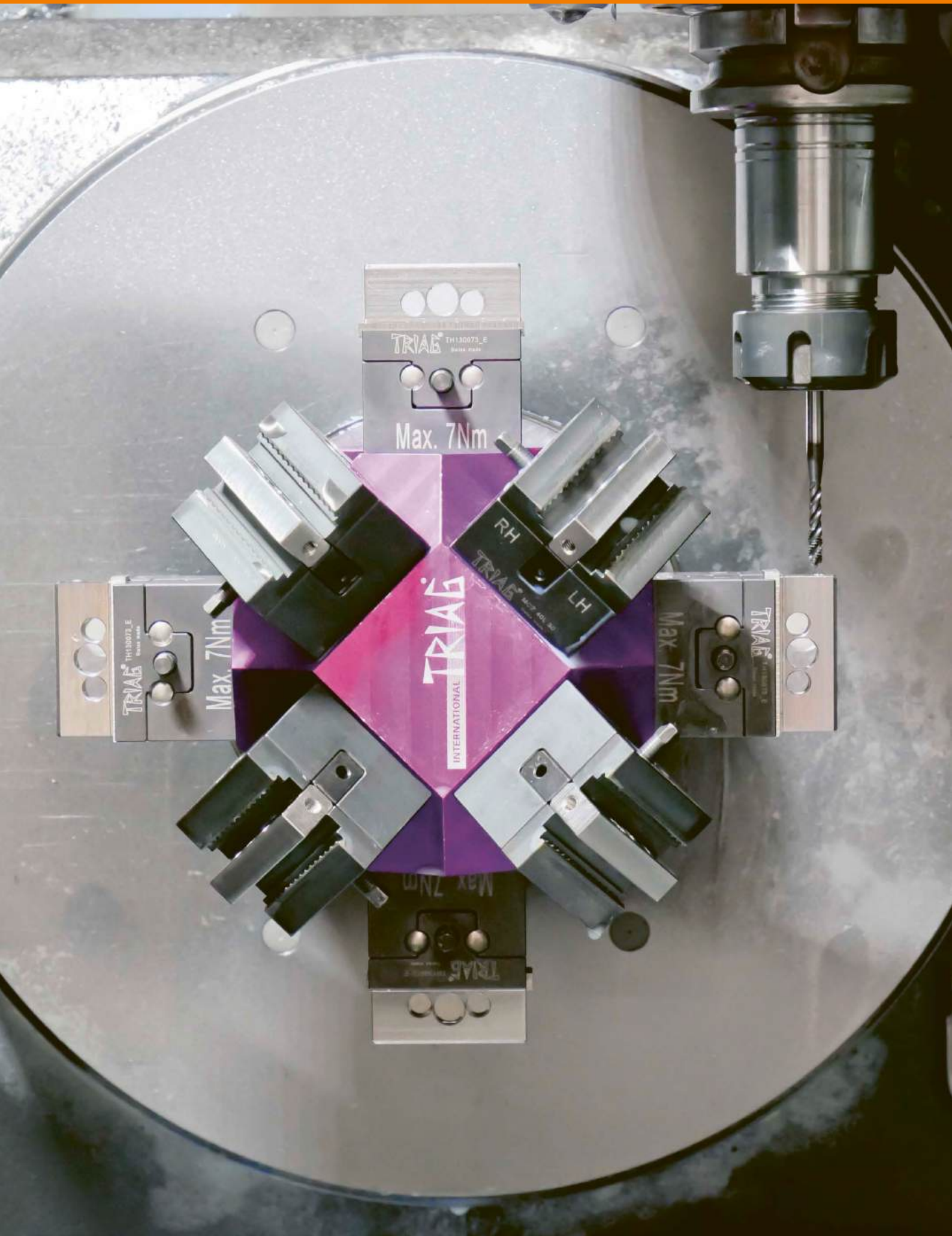

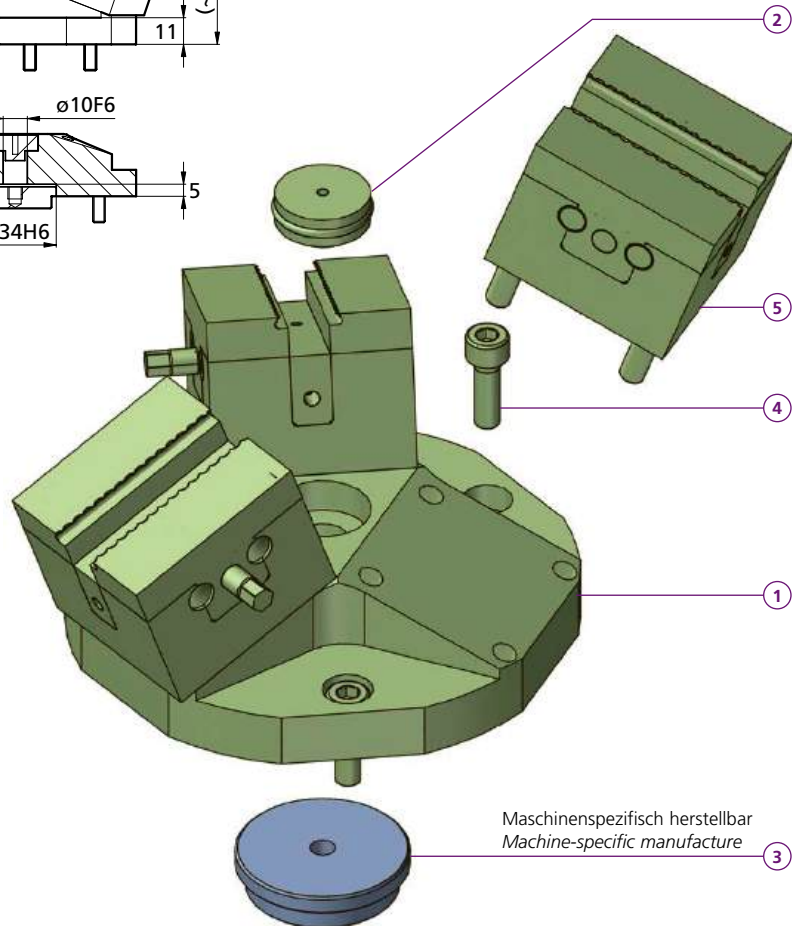
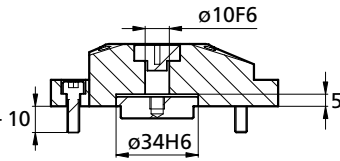
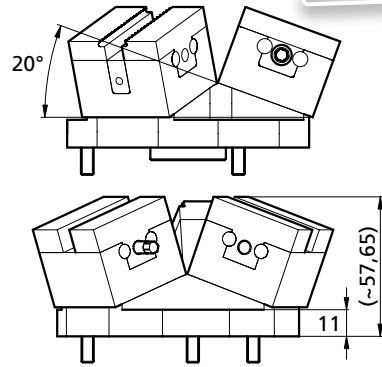
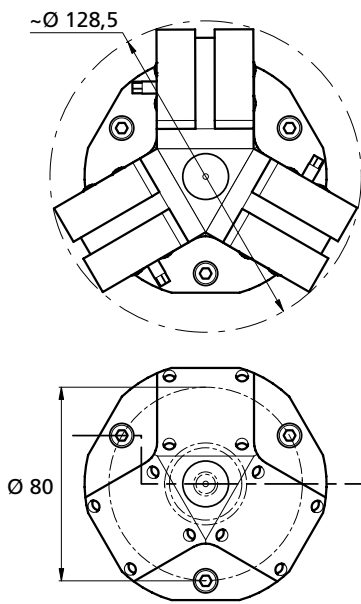

Maschinenspezifisch herstellbar  
Machine-specific manufacture

max. 7 Nm  
Nuss 1/4 - sw 4,5



20° UB5AXSET18-3

- 1 1x TH170934
- 2 1x PCPF16L6
- 3 1x TH171176
- 4 3x M5X16ISO4762
- 5 3x Ihre Wahl / Your choice

p. 116 - 117

kg ~1,45

Drehmoment und Spannkraft siehe Seite  
Torque and clamping force see page

117

NUSS 1/4" 4.5MM

WICHTIG!  
Bitte separat bestellen  
IMPORTANT!  
Please order separately



Bestellbeispiel / Ordering example : 1 x UB5AXSET18-3 & 1x TH171176 & 3x M5x16

Separat bestellen / Order separately

# Kompakter Zentralspanner Compact self centering vise

triCENTRO

Art. Nr.	Backen Jaws	A mm	B mm	kg
<b>PCZ80L40PRG62</b>	B210-62	32 – 62	6 – 35	~1,71
	B210W11-60	variabel	variabel	
	B210W20-60	variabel	variabel	

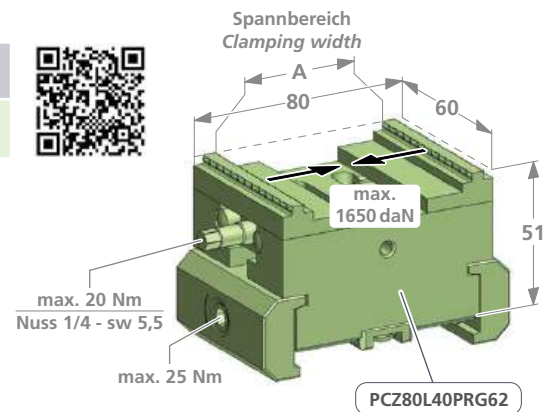

Drehmoment Torque		Spannkraft Workholding force		
Nm	(lb-ft)	~daN	~(lb)	~t
5	3,7	= 410	900	0,41
10	7,4	= 830	1'830	0,83
15	11,0	= 1'250	2'760	1,25
20	14,8	= 1'650	2'640	1,65

Für den Vorrichtungsbau  
For dedicated fixtures

Art. Nr.	Backen Jaws	A mm	B mm	kg
<b>MCZ80L32PRG62</b>	B210-62	32 – 62	6 – 35	~1,39
	B210W11-60	variabel	variabel	
	B210W20-60	variabel	variabel	

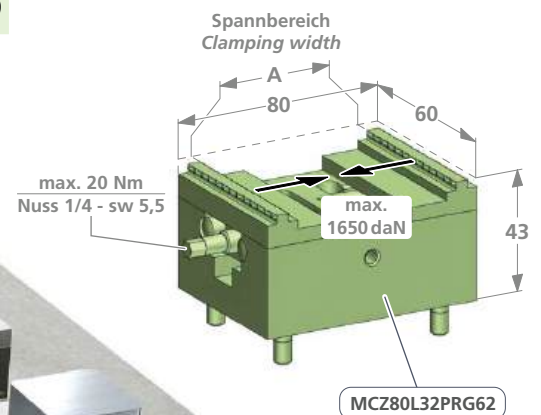

Linear- Spannbacke / Linear clamping jaw →

Art. Nr.	B210-62	B212W11-60	B212W20-60
<b>i</b>	57HRC	Vergütungsstahl Tempering steel (1.7225)	Vergütungsstahl Tempering steel (1.7225)
<b>kg</b>	~0,31	~0,31	~0,52

**NUSS 1/4" 5.5MM**

**WICHTIG!**  
Bitte separat bestellen  
**IMPORTANT!**  
Please order separately



Weich, zur Herstellung individueller Formbacke. / Soft, for the production of individual moulding jaw.

# Kompakter doppelter Zentrischspanner Compact double self centering vise

triCENTRO

Art. Nr.	Backen Jaws	A mm	B mm	kg
<b>PC2Z80L40PRG62</b>	<b>B210-26</b>	32 – 62	6 – 35	~4,7
	B210W11-60	variabel	variabel	
	B210W20-60	variabel	variabel	

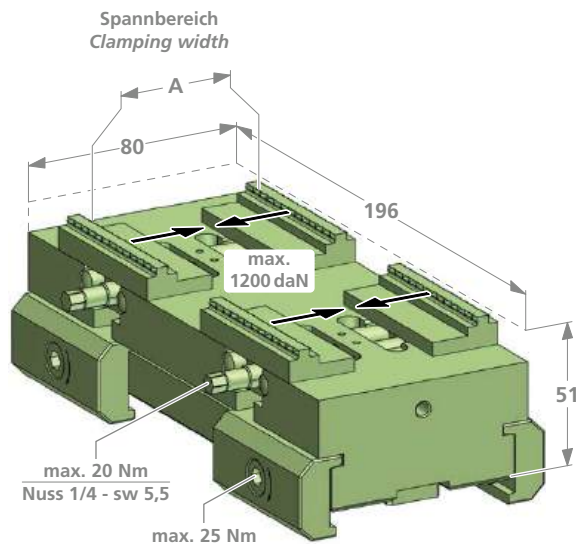

Drehmoment Torque		Spannkraft Workholding force		
Nm	(lb-ft)	~daN	~(lb)	~t
5	3,7	= 410	900	0,41
10	7,4	= 830	1'830	0,83
15	11,0	= 1'250	2'760	1,25
20	14,8	= 1'650	2'640	1,65



## Linear- Spannbacke / Linear clamping jaw

Art. Nr.	<b>B210-62</b>	<b>B212W11-60</b>	<b>B212W20-60</b>
<b>i</b>	57HRC	Vergütungsstahl Tempering steel (1.7225)	Vergütungsstahl Tempering steel (1.7225)
<b>kg</b>	~0,31	~0,31	~0,52

Weich, zur Herstellung individueller Formbacke. / Soft, for the production of individual moulding jaw.

### NUSS 1/4" 5.5MM

**WICHTIG!**  
Bitte separat bestellen  
**IMPORTANT!**  
Please order separately





Zwei Mini - Zentrischspanner mit Direktprägebacken halten verschieden lange Titanbleche. Um die verschiedenen Längen zu adaptieren, können die Spanner in 2 mm schritten seitlich versetzt werden.

Two mini - self centering vises with direct stamping jaws holding titanium sheets in different length. To adapt the different length's the vises can be moved side words in 2 mm steps.

Sondervorrichtung für Velo-Pedale mit dem schnellwechsel Nullpunkt-System OPP  
Dedicated fixture for high end bicycle pedals with quick change system OPP

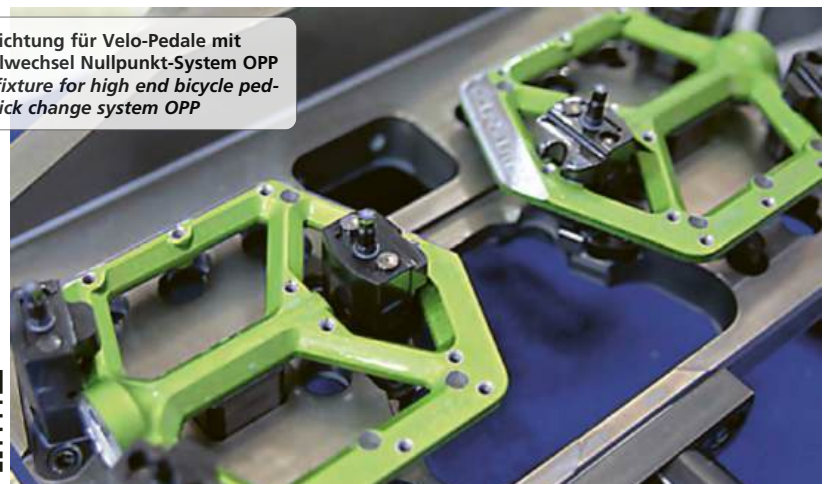

siehe Video  
see video



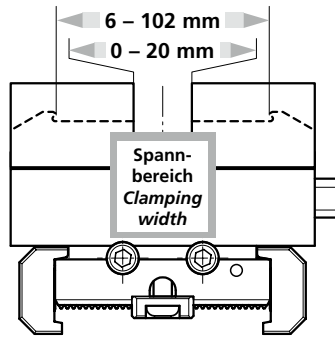
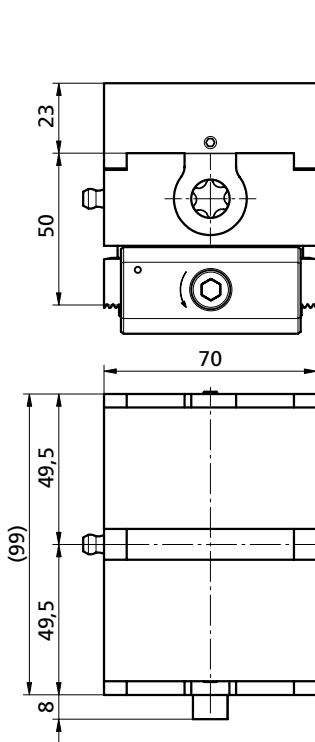

Drehmoment Torque		Spannkraft Workholding force		
Nm	(lb-ft)	~daN	~(lb)	~t
10	7,4	= 200	440	0,2
20	14,8	= 500	1'102	0,5
30	22,2	= 1'000	2'204	1,0
40	29,6	= 1'300	2'866	1,3
50	37,0	= 1'600	3'527	1,6

### Innenspannung-Set / Inner clamping set

Mit diesem Set ist es möglich das Werkstück von innen zu spannen. *With this set it is possible to clamp the workpiece from the inside.*

#### ACHTUNG / CAUTION

Folgende Spannbacken sind dazu nicht geeignet.

*The following clamping jaws are not suitable for this purpose.*

**B175-102, B175-121,  
B173-102**

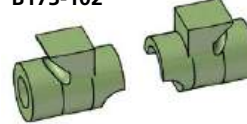

**PCZS2439-ID-SET**

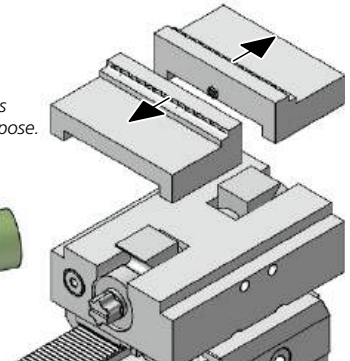

Nullpunkt des Zentrischspanners neu einstellen  
*How to readjust the zero point adjustment*

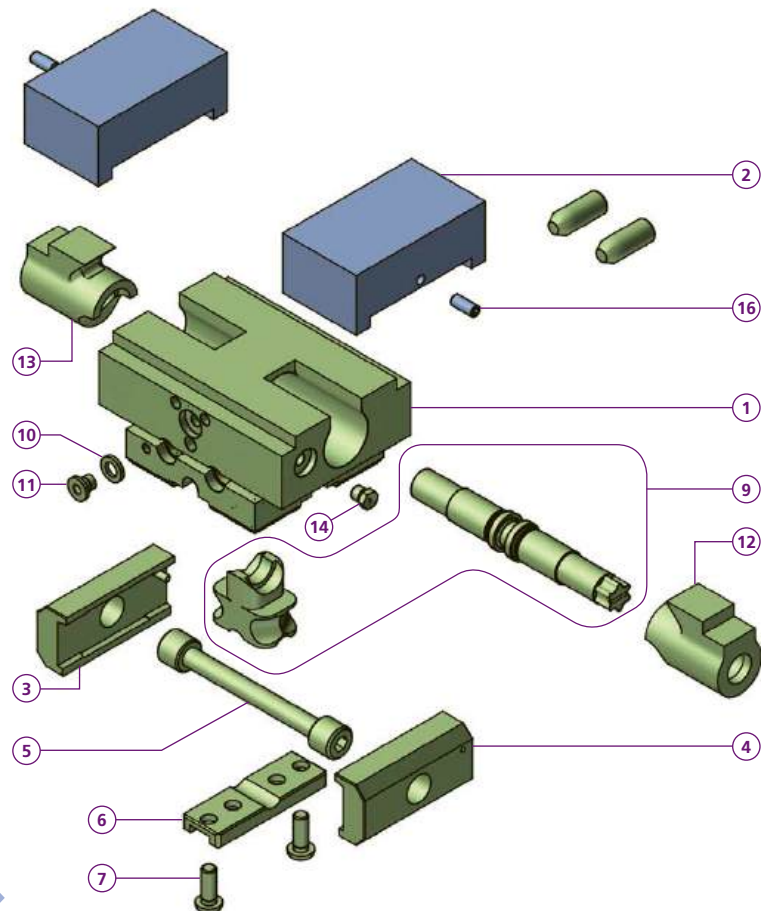
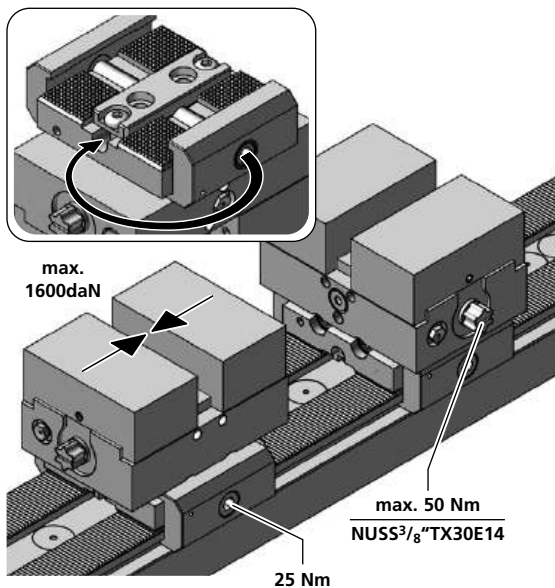

PCZ100L50	
1	1x PCZ100L50M
2	2x
3	1x PCSP60L
4	1x PCSP60R
5	1x PCS14
6	1x PCGUW20
7	2x M6X16ISO7380
9	1x PCS14M107SET
10	1x BN726 ISO 7092 M6
11	1x BN1206 M6x6
12	1x PCZS2439L
13	1x PCZS2439R
14	1x PCZSNP
15	4x PCZJ1025
16	2x TN100140
kg	~2,5

p. 128 - 129

### NUSS3/8"TX30E14

**WICHTIG!**  
Bitte separat bestellen  
**IMPORTANT!**  
Please order separately



Bestellbeispiel / Ordering example:  
3 x PCZ100L50 & 6 x B170 & 1 x NUSS3/8"TX30E14

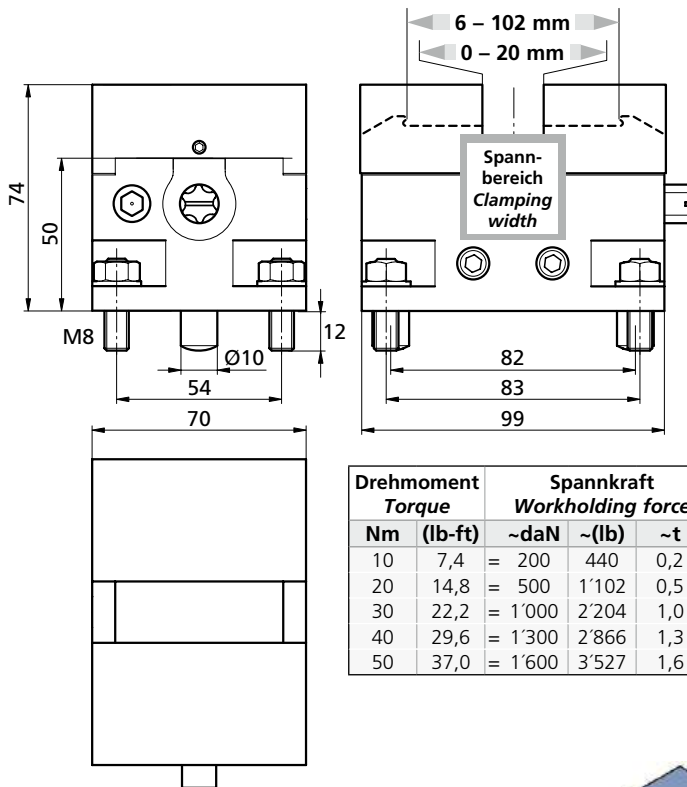

Drehmoment Torque		Spannkraft Workholding force		
Nm	(lb-ft)	~daN	~(lb)	~t
10	7,4	= 200	440	0,2
20	14,8	= 500	1'102	0,5
30	22,2	= 1'000	2'204	1,0
40	29,6	= 1'300	2'866	1,3
50	37,0	= 1'600	3'527	1,6

### Innenspannung-Set / Inner clamping set

Mit diesem Set ist es möglich das Werkstück von innen zu spannen. *With this set it is possible to clamp the workpiece from the inside.*

#### ACHTUNG / CAUTION

Folgende Spannbacken sind dazu nicht geeignet.

*The following clamping jaws are not suitable for this purpose.*

**B175-102, B175-121, B173-102**

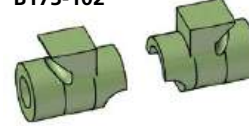

**PCZS2439-ID-SET**

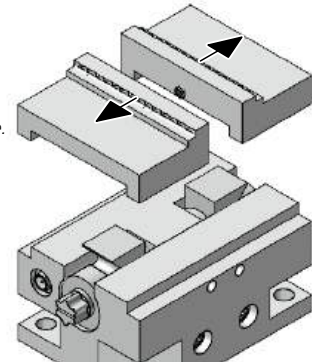

Nullpunkt des Zentrischspanners neu einstellen  
*How to readjust the zero point adjustment*

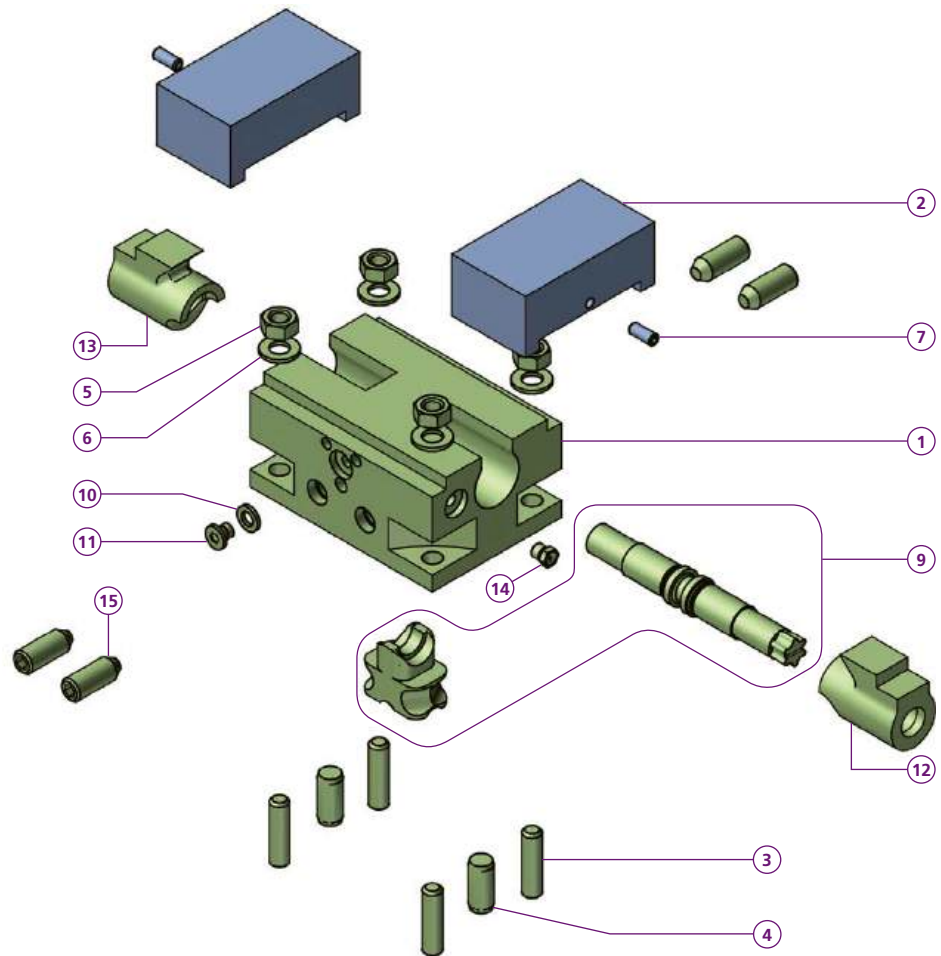
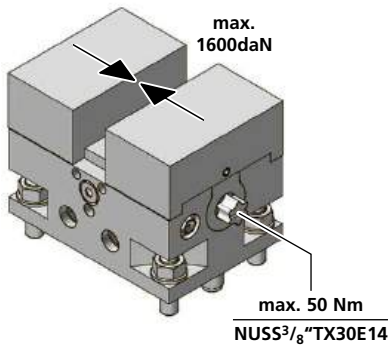

MCZ100L50	
1	1x MCZ100L50M
2	2x —
3	2x 10m6x22 ISO 8734
4	4x M8X30DIN913
5	4x M8 DIN 934
6	4x 8,4 DIN 125 A
7	2x TN100140
9	1x PCS14M107SET
10	1x BN726 ISO 7092 M6
11	1x BN1206 M6x6
12	1x PCZS2439L
13	1x PCZS2439R
14	1x PCZSNP
15	4x PCZJ1025
kg	~2,6

p. 128 - 129

### NUSS3/8"TX30E14

**WICHTIG!**  
Bitte separat bestellen  
**IMPORTANT!**  
Please order separately

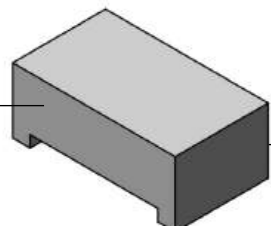
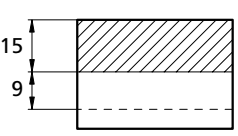
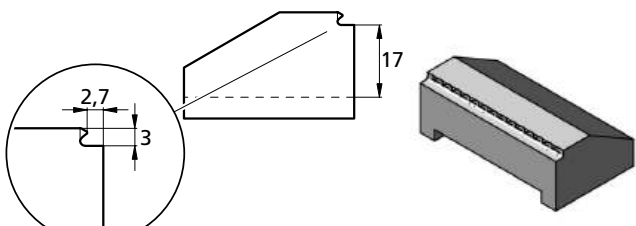
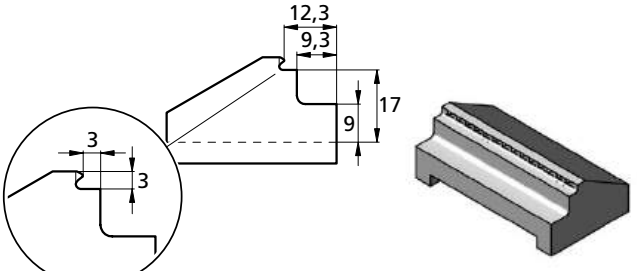
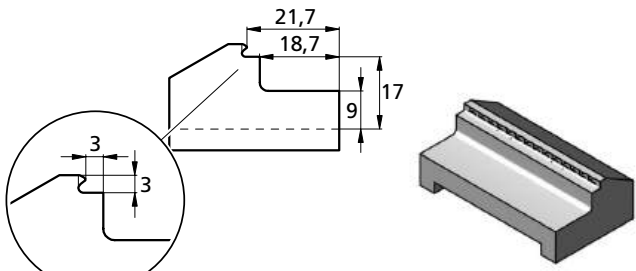
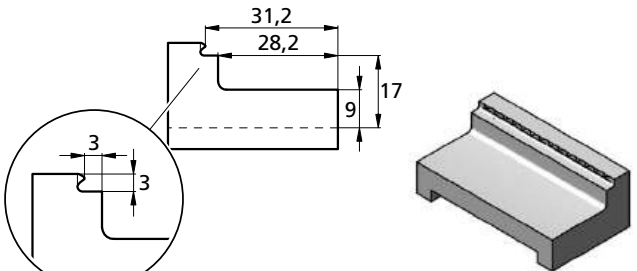
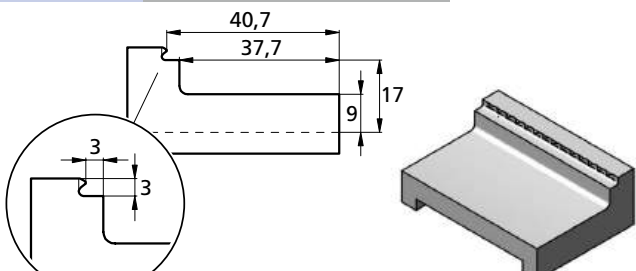
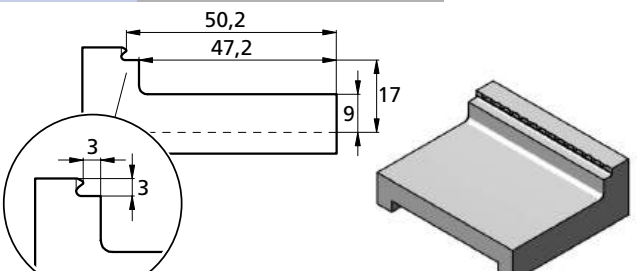

Bestellbeispiel / Ordering example:  
3 x MCZ100L50 & 6 x B170 & 1 x NUSS3/8"TX30E14

<p><b>B170, B172</b> Spannereich / Clamping width ◀ 0 – 20 mm ▶</p>  <p>B170 HV700 x 0,2 mm</p> <p>B172</p> <p>weich soft 1.7225</p>	<p>Zum Erstellen Ihrer individuellen Formbacke: Schnittzeichnung zum Ermitteln der maximalen Bearbeitungs- profiltiefe</p> <p><i>If a dedicated jaw is being machined:</i> Sectional drawing to determine the maximum machining depth</p>  <p>für / for B170, B172</p>
<p><b>B175-26</b> Spannereich / Clamping width ◀ 6 – 26 mm ▶</p> 	<p><b>B175-45</b> Spannereich / Clamping width ◀ 25 – 45 mm ▶</p> 
<p><b>B175-64</b> Spannereich / Clamping width ◀ 44 – 64 mm ▶</p> 	<p><b>B175-83</b> Spannereich / Clamping width ◀ 63 – 83 mm ▶</p> 
<p><b>B175-102</b> Spannereich / Clamping width ◀ 82 – 102 mm ▶</p> 	<p><b>B175-121</b> Spannereich / Clamping width ◀ 101 – 121 mm ▶</p> 

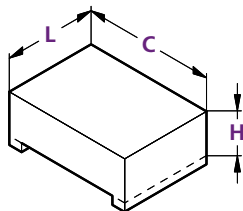

	B170	B172	B175-26	B175-45	B175-64	B175-83	B175-102	B175-121	B175SET
<b>B</b>									
<b>C</b>	70	70	70	70	70	70	70	70	2x B175-26
<b>H</b>	24	24	20	20	20	20	20	20	2x B175-45
<b>L</b>	40	40	40	40	40	40	50	60	2x B175-64
<b>i</b>	HV700 x0,2mm	*	57HRC	57HRC	57HRC	57HRC	57HRC	57HRC	2x B175-83
<b>kg</b>	~0,5	~0,5	~0,34	~0,29	~0,28	~0,25	~0,31	~0,37	2x B175-102



\* = weich / soft (1.7225 Vergütungsstahl / Tempering steel)

<p><b>B173-26</b> Spannereich / Clamping width ◀ 6 – 26 mm ▶</p>	<p><b>B173-45</b> Spannereich / Clamping width ◀ 25 – 45 mm ▶</p>
<p><b>B173-64</b> Spannereich / Clamping width ◀ 44 – 64 mm ▶</p>	<p><b>B173-83</b> Spannereich / Clamping width ◀ 63 – 83 mm ▶</p>
<p><b>B173-102</b> Spannereich / Clamping width ◀ 82 – 102 mm ▶</p>	<p><b>B176-80</b> Spannereich / Clamping width ◀ 8 – 80 mm ▶</p> <p>2x Inklusive /Included PRG1003M8</p>
<p><b>ZK160798M5</b></p> <p><b>Extra Zubehör:</b>          Schraube zum schnellen Wechseln der Backen</p> <p><b>Additional accessories:</b>          Screw for quick change of jaws</p>	<p><b>PRG1003M8</b></p> <p><b>Bohrbild          Hole pattern</b></p>

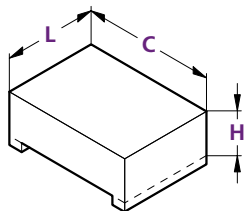



Bestellbeispiel / Ordering example: 2 x B173-26

<b>B</b>	B173-26	B173-45	B173-64	B173-83	B173-102	B176-80	B173SET
<b>C</b>	70	70	70	70	70	70	2x B173-26
<b>H</b>	24	24	24	24	24	20	2x B173-45
<b>L</b>	40	40	40	40	50	40	2x B173-64
<b>i</b>	HV700	HV700	HV700	HV700	HV700	HV700	2x B173-83
	x0,2mm	x0,2mm	x0,2mm	x0,2mm	x0,2mm	x0,2mm	2x B173-102
<b>kg</b>	~0,31	~0,32	~0,32	~0,28	~0,34	~0,4	



Separat bestellen / Order separately

Doppelte Spannung – doppelt effizient  
Twice the clamping – twice the efficiency

Art. Nr.	kg	Backen Jaws	A = 2 x
<b>B172-MB</b>	~0,3	B172	variabel
 weicher Stahl soft steel (1.7225)			
<b>B173-MB</b>	~0,3	B173-45	10 – 17 mm
 HV700 x 0,2mm		B173-64	17 – 27 mm
		B173-83	27 – 37 mm
		B173-102	36 – 46 mm
		B175-121	46 – 55 mm
<b>B175-MB</b>	~0,3	B175-45	8 – 16 mm
 57HRC		B175-64	16 – 26 mm
		B175-83	25 – 35 mm
		B175-102	35 – 45 mm
		B175-121	45 – 54 mm

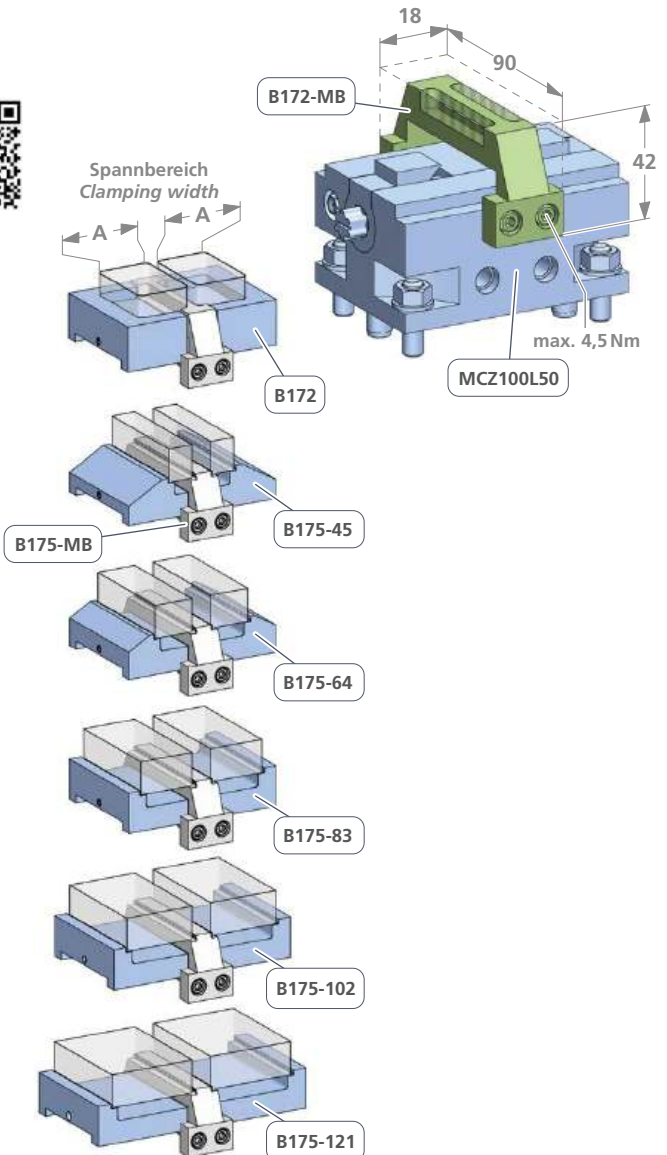

Die Anschlagbrücken **B172-MB**, **B173-MB** und **B175-MB** können in Kombination mit den Zentrischspannern PCZ100L50 / MCZ100L50 als Doppelspanner eingesetzt werden.

The **B172-MB**, **B173-MB**, and **B175-MB** stop bridges can be used as double clamps in combination with the PCZ100L50 / MCZ100L50 self centering vise.



Folgende Spannbacken sind dazu nicht geeignet.

The following clamping jaws are not suitable for this purpose.

**B170**, **B173-26**, **B175-26**, **B176-80**

#### ACHTUNG / CAUTION

Beim Einsatz der Anschlagbrücke muss der Spanner schwimmend eingestellt werden, dabei werden die vier Zentrierschrauben entfernt.

When using the stop bridge, the tensioner must be adjusted to float, removing the four centring screws in the process.

**Montageanleitung der Anschlagbrücke auf dem Mini-Zentrischspanner**  
Operating instructions for this self centering vise



**MINI**

**Zentrischspanner mit Anschlagbrücke**  
*Self centering vise with center stop*

**triCENTRO**

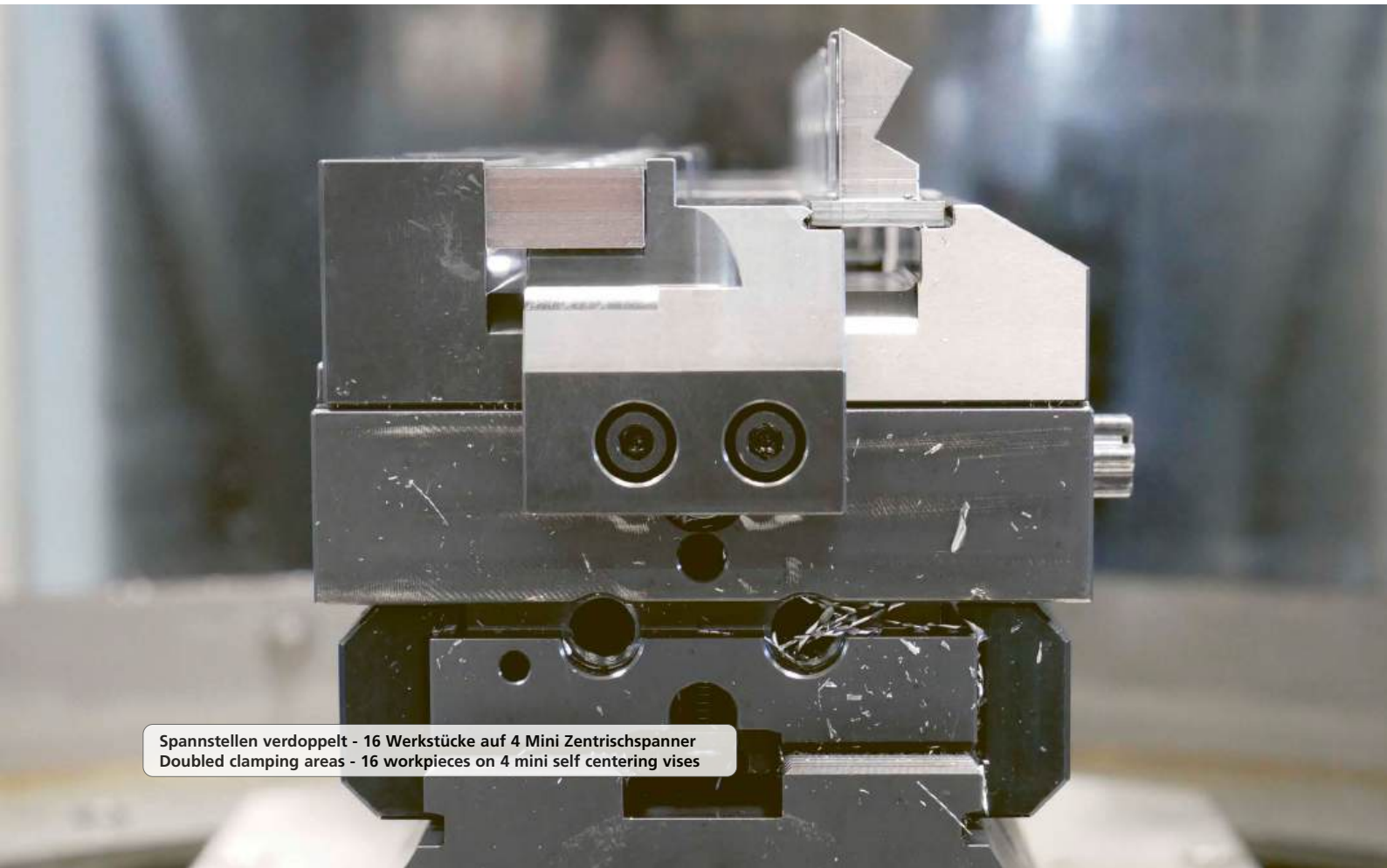
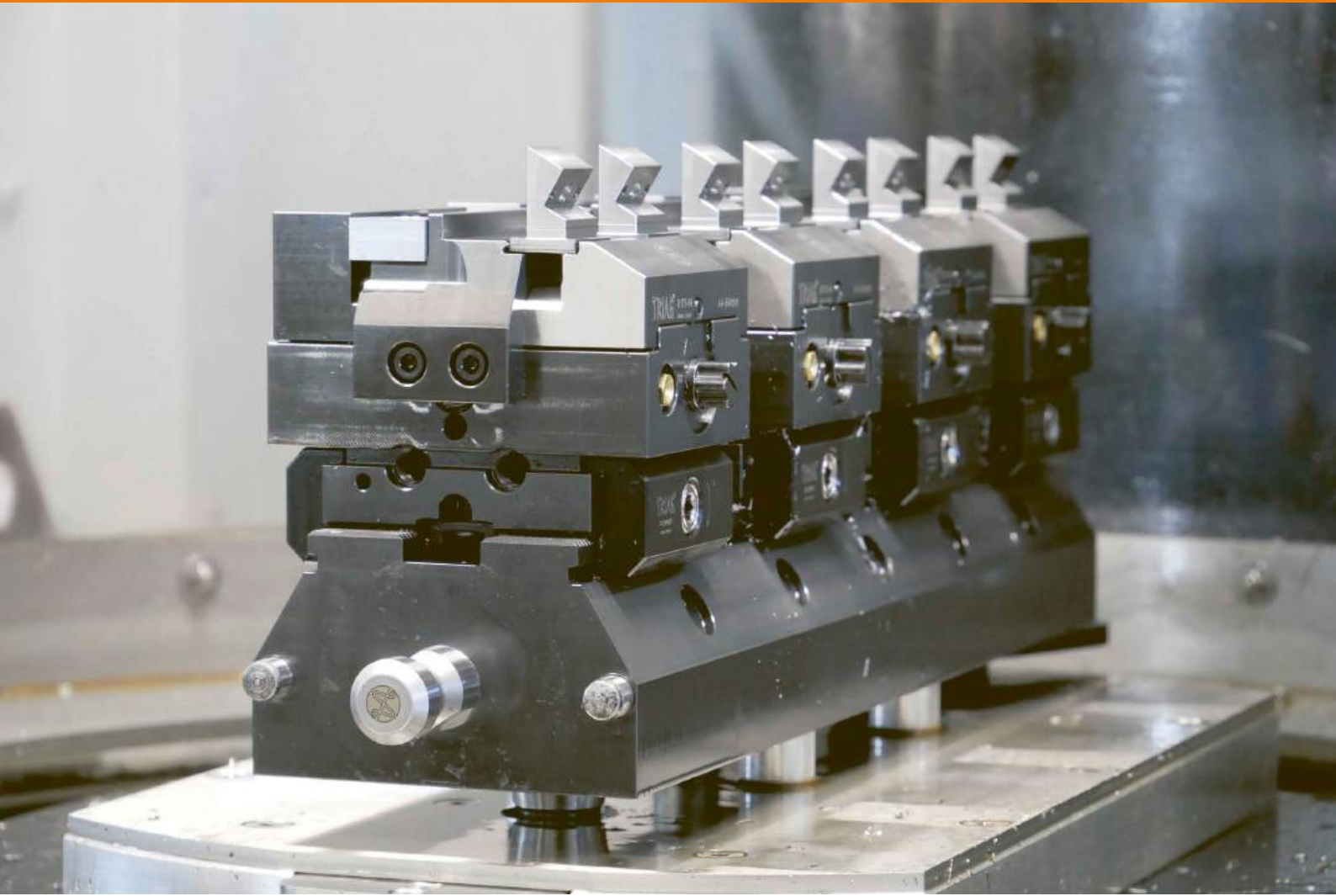

Spannstellen verdoppelt - 16 Werkstücke auf 4 Mini Zentrischspanner  
Doubled clamping areas - 16 workpieces on 4 mini self centering vises

Diese Spannbacken sind für die Innenspannung geeignet.  
These clamping jaws are suitable for internal clamping.

Diese Spannbacken sind für die Spannung mit der Anschlagbrücke geeignet.  
These clamping jaws are suitable for clamping with the stop bridge.

14 verschiedene Backenvarianten passend zu dieser Schnellwechselschnittstelle.  
More than 14 different jaw modules to match this rapidly changing interface.

PCZ100L50    MCZ100L50    p. 130    B172-MB    PCZS2439-ID-SET    p. 126

SPACEGRIP II

**spaceGRIP II**

Ein einzigartig auf Modulbauweise ausgelegtes Spannkonzzept für den Einsatz der Zentrischspanner **MCZ100L50**.

Es können 4, 8 oder gar 12 Spanner, je nach Wunsch, eingesetzt werden. Das Ganze ist so modular wie ein «Lego»-Baukasten-System. Wieder stehen Prägebacken, weiche Backen und zusätzlich Stufen- und Universalbacken zur Verfügung. Sogar das Zentrum der einzelnen Spannstöcke kann eingestellt werden.

**spaceGRIP II**

A unique clamping concept with modular construction design for using the self-centering vice **MCZ100L50**.

Four, eight or even twelve clamping vices can be used as needed. The whole system is modular like a «Lego» building kit. Again, stamping jaws, soft jaws and universal as well as stepped jaws are available. Even the centre of the individual vices can be adjusted.

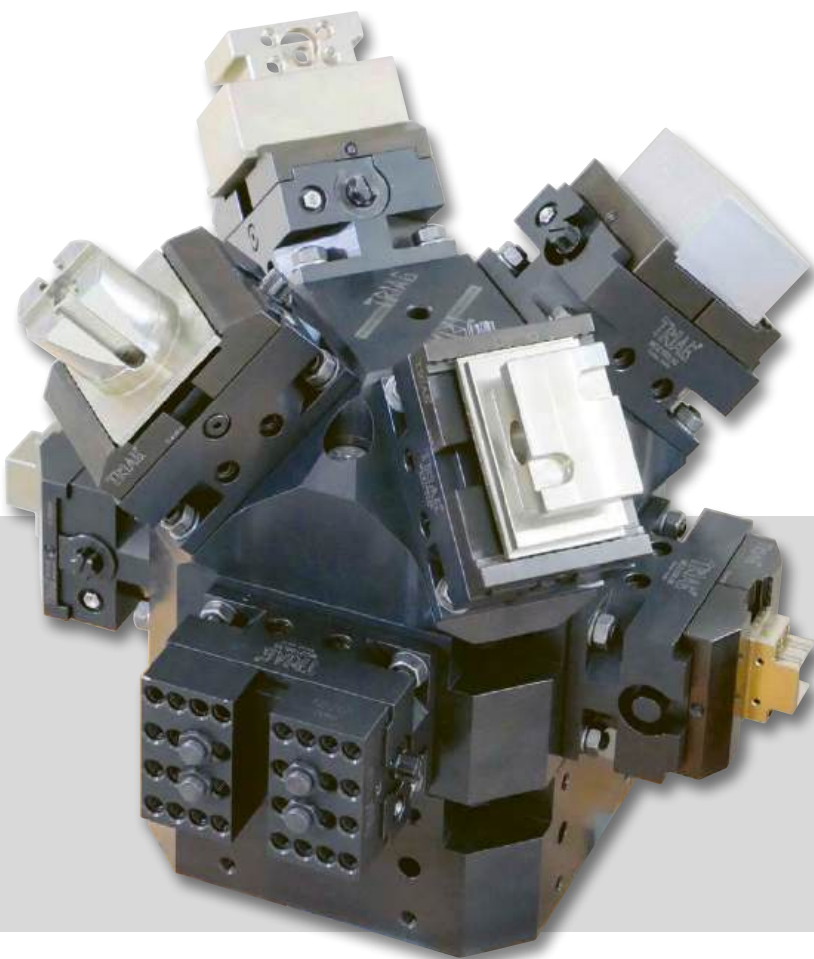

SPACEGRIP II

SPACEGRIP II

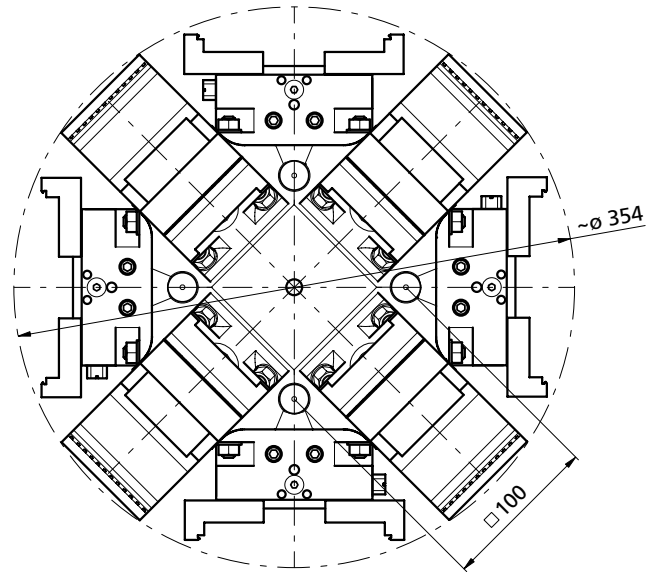
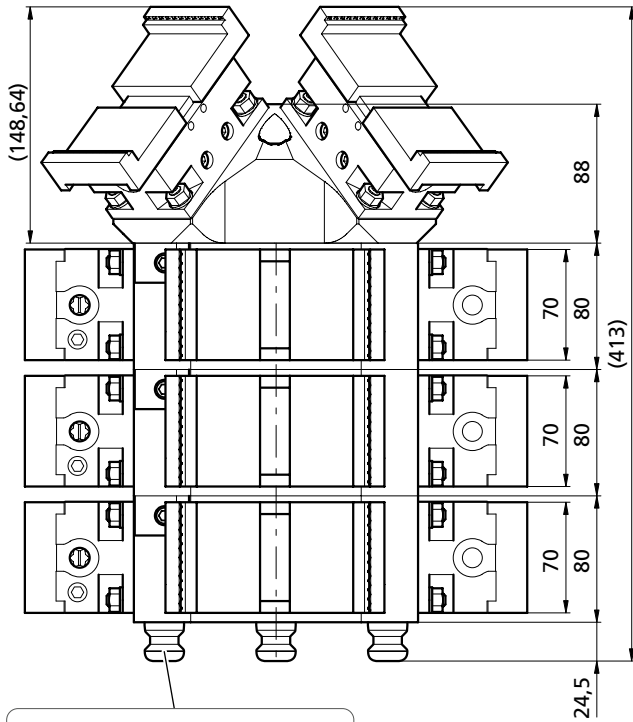

OPP-Schnittstelle Nullpunkt-System  
OPP interface Zero-point system

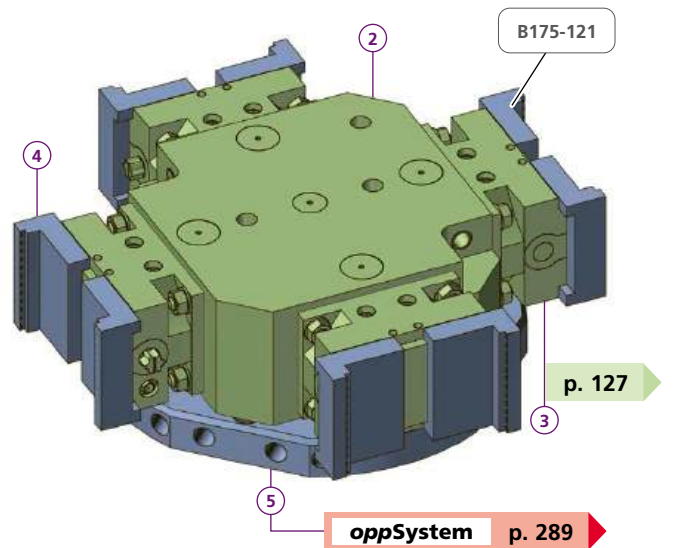
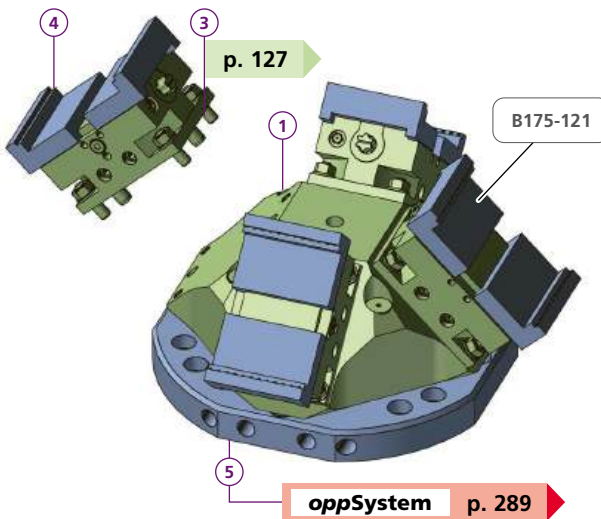

<b>5AXMCZ100-45-4</b>	
1	1x TS160110
3	4x MCZ100L50
4	8x
5	1x TB160379
kg	~22,8



Detailzeichnung  
zu dieser  
Schnittstelle  
Detail drawing  
to interface

<b>5AXMCZ100-90-4</b>	
2	1x TS160111
3	4x MCZ100L50
4	8x
5	1x TB160379
kg	~25,5



Detailzeichnung  
zu dieser  
Schnittstelle  
Detail drawing  
to interface

Bestellbeispiel / Ordering example : 1 x 5AXMCZ100-90-4 & 8 x B175-121

SPACEGRIP II

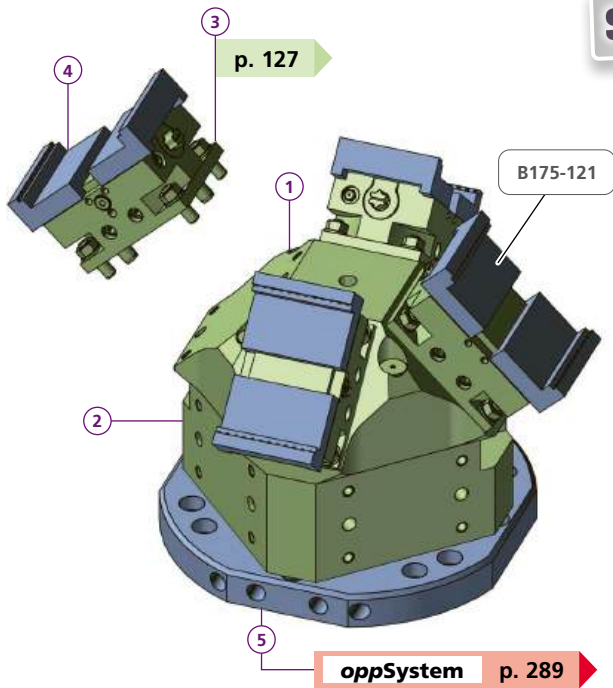

<b>5AXMCZ100-45-4H</b>	
1	1x TS160110
2	1x TS160111
3	4x MCZ100L50
4	8x ————— p. 128 - 129
5	1x TB160379
kg	~38,1



Detailzeichnung zu dieser Schnittstelle  
Detail drawing to interface

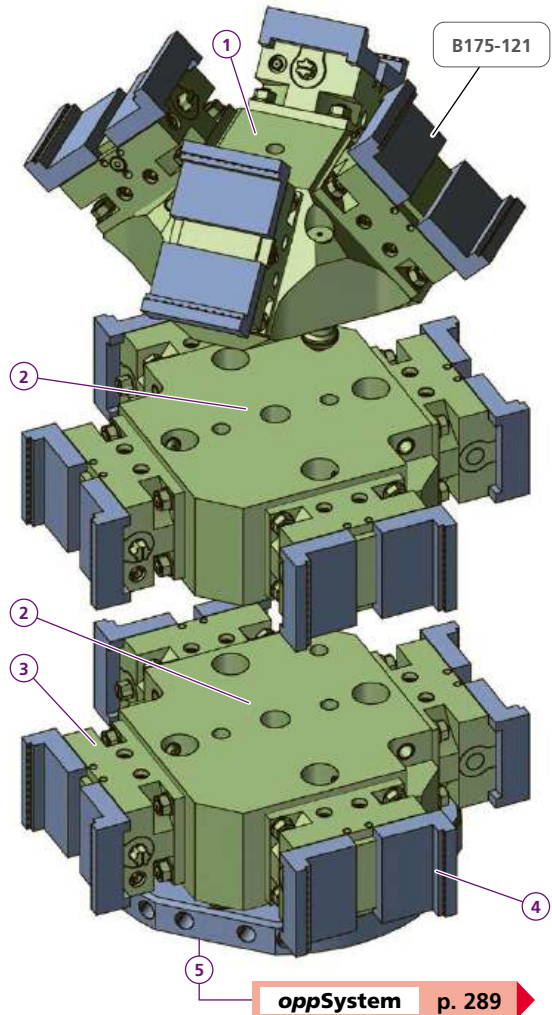

<b>5AXMCZ100-45-12</b>	
1	2x TS160110
2	1x TS160111
3	12x MCZ100L50
4	24x ————— p. 128 - 129
5	1x TB160379
kg	~73,8



Detailzeichnung zu dieser Schnittstelle  
Detail drawing to interface

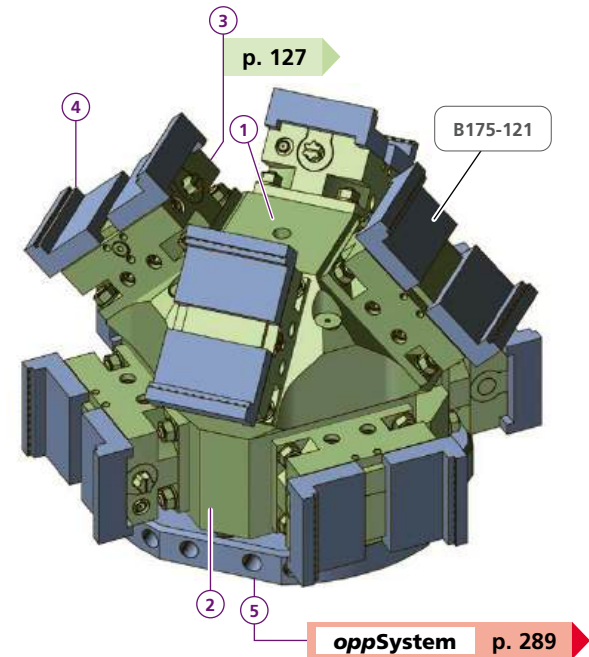

<b>5AXMCZ100-45-8</b>	
1	1x TS160110
2	1x TS160111
3	8x MCZ100L50
4	16x ————— p. 128 - 129
5	1x TB160379
kg	~48,3



Detailzeichnung zu dieser Schnittstelle  
Detail drawing to interface

Bestellbeispiel / Ordering example: 1 x 5AXMCZ100-45-8 & 16 x B175-121

SPACEGRIP II-3

Art. Nr.	kg
5AXMCZ100-45-3	~18
5AXMCZ100-45-3H	~35
5AXMCZ100-45-6	~43

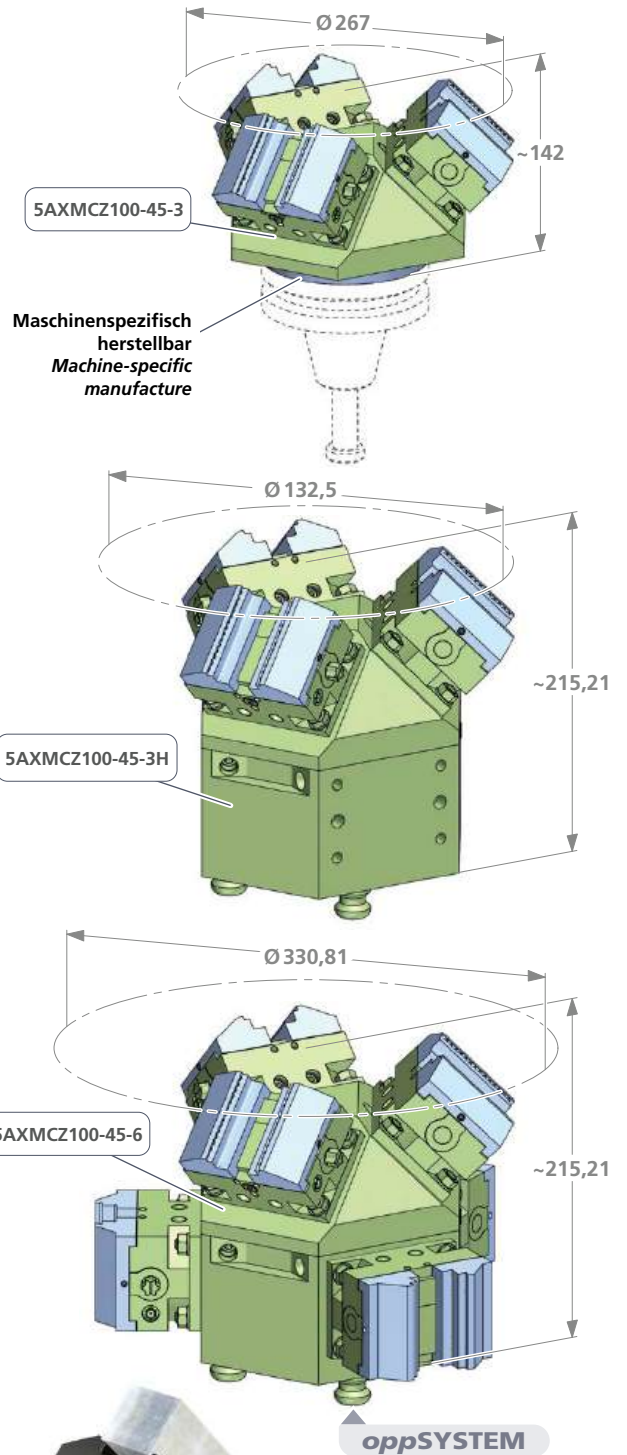

Bei dieser Pyramidenlösung ist die Zugänglichkeit der Spindel beim Bearbeiten von Werkstücken sehr gut.  
With this pyramid solution, the accessibility of the spindle is very good when machining workpieces.

Anschlagbrücke  
Center stop  
p. 130



# Zentrischspanner der Serien Self centering vises of the series

# ZSX | ZSM | ZSQ

triCENTRO

## Durchgehend modular!

Clevere Zentrischspanner passen sich der Maschine, den Werkstücken und den Anforderungen an.

## Throughout modular!

Clever self centering vises which adapts to the machine, the workpiece and the requirements.

**X**

Spannkrafterhaltung  
und Nachfederung

Spring loaded  
mechanism to maintain  
clamping force

**M**

Mehr als 64 verschiedene  
Backenvarianten passend  
zu dieser Schnellwechsel-  
schnittstelle.

More than 64 different  
jaw modules to match this  
rapidly changing interface.

**Q**

Schnellwechselbacken  
Spannkrafterhaltung  
und Nachfederung

Quick-change jaws  
Spring loaded  
mechanism to maintain  
clamping force

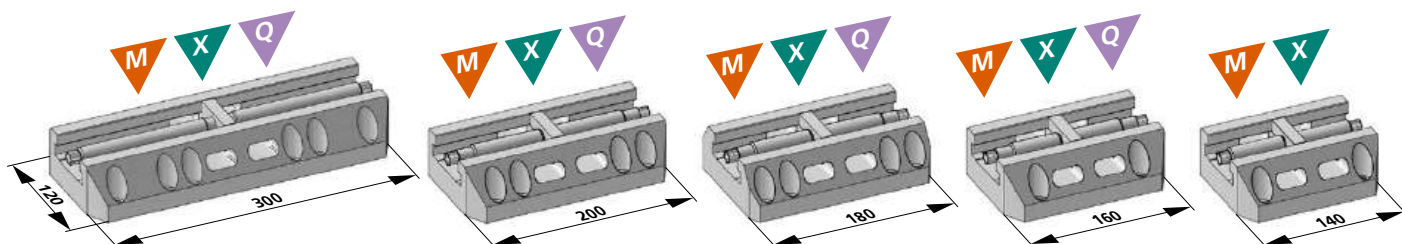
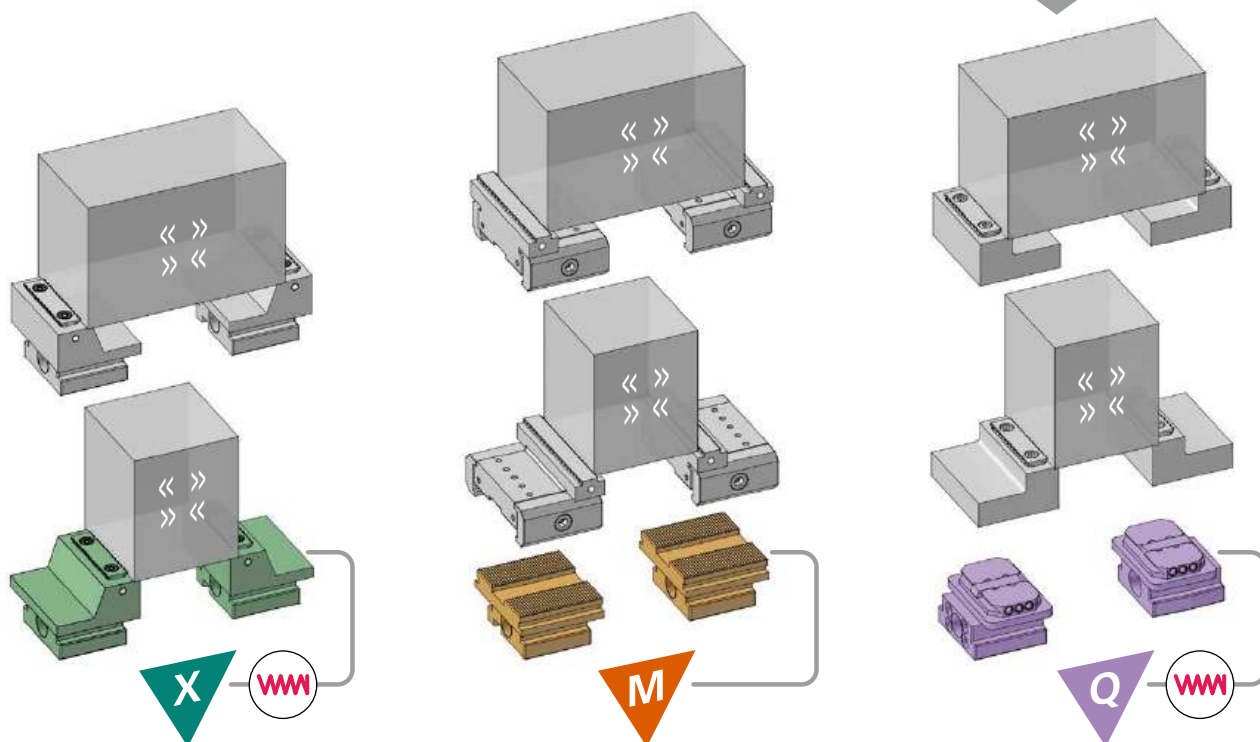

Art. Nr.	kg
ZS <b>X</b> 300L50UPRG	~10,65
ZS <b>X</b> 200L50UPRG	~8,8
ZS <b>X</b> 180L50UPRG	~8,1
ZS <b>X</b> 160L50UPRG	~7,7
ZS <b>X</b> 140L50UPRG	~7,1

Art. Nr.	kg
ZS <b>M</b> 300L50UPRG	~10,5
ZS <b>M</b> 200L50UPRG	~7,4
ZS <b>M</b> 180L50UPRG	~6,9
ZS <b>M</b> 160L50UPRG	~6,4
ZS <b>M</b> 140L50UPRG	~5,7

Art. Nr.	kg
ZS <b>Q</b> 300L50UPRG	~11,1
ZS <b>Q</b> 200L50UPRG	~8,1
ZS <b>Q</b> 200L50UPRG	~8,1
ZS <b>Q</b> 180L50UPRG	~7,5
ZS <b>Q</b> 160L50UPRG	~7,0

### Zentrischspanner mit Spannkrafterhaltung und Direkt-Prägebacken

- ✓ für die erste Aufspannung mittels Direkt-Prägebacken ab 3 mm
- ✓ Einzigartiges integriertes Federpaket
- ✓ Beste Zugangs-Möglichkeit
- ✓ für OP10 und OP20 ausgelegt
- ✓ Bestens geeignet für 5-Achsen Maschinen mit kleinerem Tisch
- ✓ Bestens geeignet für den Einsatz auf Rundtischen

### Self-centering vise with spring loaded mechanism and direct stamping jaws

- ✓ for the first clamping using direct stamping jaws from 3 mm
- ✓ Unique integrated spring package
- ✓ Best access option
- ✓ Designed for OP10 and OP20
- ✓ Ideally suited for 5-axis machines with smaller tables
- ✓ Ideally suited for use on rotary tables

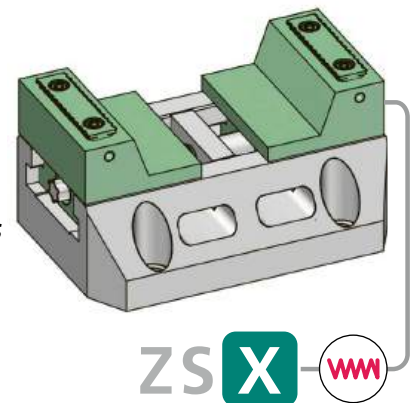

ZSX

### Zentrischspanner für den Einsatz mit Power Clamp Modulen

- ✓ Höchste Modularität, alle Power Clamp Module können eingesetzt werden
- ✓ Schneller Backenwechsel (eine Schraube lösen und Modul nach oben abheben)
- ✓ Backen von 19 bis 150 mm
- ✓ weiche Backen
- ✓ Direktprägebacken und Bearbeitung ab 3 mm

### Self-centering vice for use with Power Clamp modules

- ✓ Highest modularity, all Power Clamp modules can be used
- ✓ Quick jaw change (loosen one screw and lift the module up)
- ✓ Jaws from 19 to 150 mm
- ✓ soft jaws
- ✓ Direct stamping jaws, machining from 3 mm

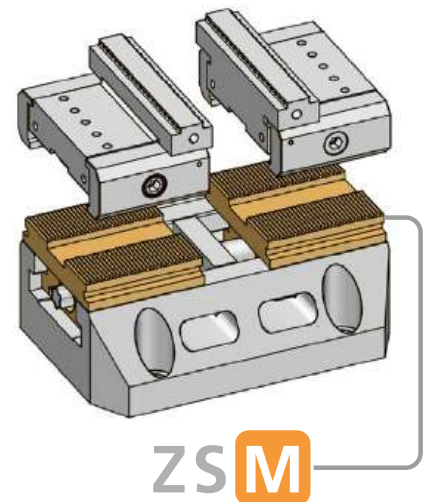

ZSM

### Zentrischspanner für den Einsatz von Schnellwechselbacken

- ✓ Schnellwechselbacken (werden per Hand auf dem Spanner eingeklinkt)
- ✓ Weiche Backen zum selbst bearbeiten
- ✓ Direktprägebacken für OP10
- ✓ Einzigartiges integriertes Federpaket
- ✓ Für Rohteile können pendelnde Schlitten (P) eingesetzt werden

### Self-centering vice for the use of quick-change jaws

- ✓ Quick-change jaws (clicked on the vise by hand)
- ✓ Soft jaws for individual machining
- ✓ Direct stamping jaws for OP10
- ✓ Unique integrated spring package
- ✓ Pendulum slides (P) can be used for unmachined parts

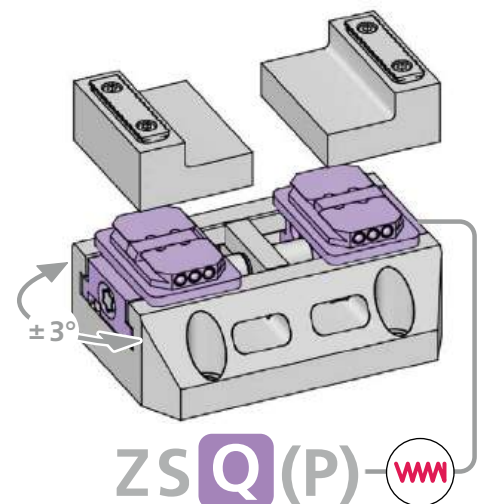

ZSQ(P)

Drehmoment Torque		Spannkraft Workholding force			Gut zu Wissen Good to know
Nm	(lb-ft)	~daN	~(lb)	~t	
10	7,4	= 200	440	0,2	Diese Spannkräfte werden für den Dauerbetrieb empfohlen! These clamping forces are recommended for continuous operation!
20	14,8	= 500	1'102	0,5	
30	22,2	= 1'000	2'204	1,0	
40	29,6	= 1'300	2'866	1,3	
50	37,0	= 1'600	3'527	1,6	
60	44,4	= 1'800	3'968	1,8	Für kurzfristige Anwendung For short-term application
70	51,8	= 2'100	4'629	2,1	

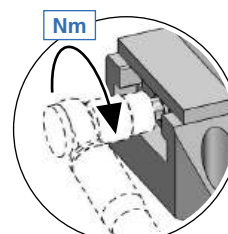

ZSM200L50 & PAND94-49PRG-A1

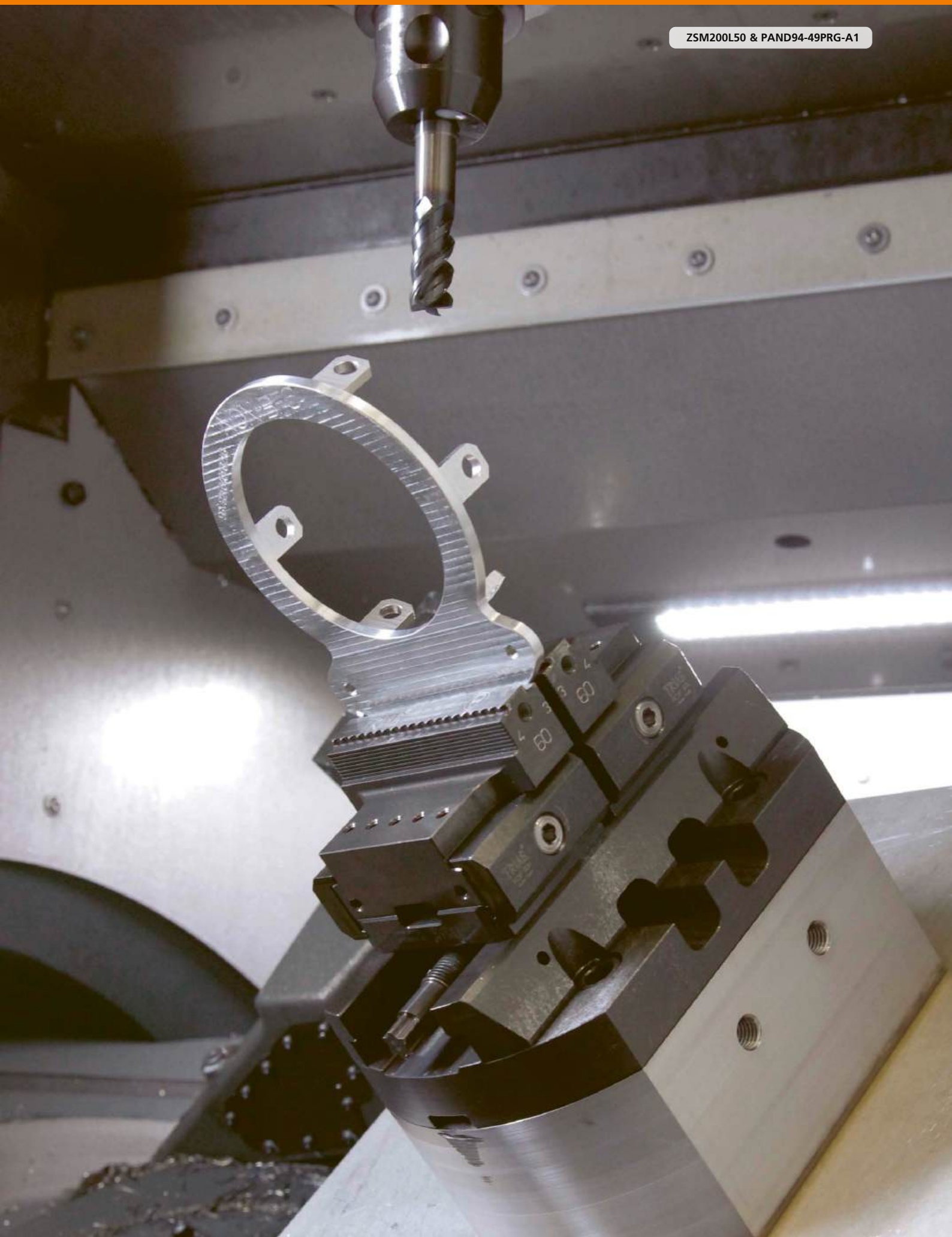

#### Direkt-Prägebacken

Bei knapp gespannten Werkstücken, speziell in weichen Materialien, wie Alu und Rostfrei aber auch in praktisch allen anderen Materialien, besteht das Problem, dass sich die Werkstücke freiwiegeln! Dies vor allem bei weit auskragenden Werkstücken bei der 5-Achsen Bearbeitung, selbst wenn vorgeprägt wird.

Triag International hat deshalb einen nachfedernden Zentrisch Spannstock entwickelt, welcher ein Freiwiegeln der Werkstücke mittels Nachfederung verhindert.

Bei diesem patentiertem System wird mittels Tellerfedern eine Backe des Zentrischspannstockes nachgeschoben. So wird der Spanndruck aufrechtgehalten. Die Einspanntiefe ist im Normalfall 3 mm, kann aber verstellt werden von ca. 1,8 bis 6 mm. Das Werkstück kann sich so praktisch nicht freiwiegeln.

Das heisst, man hat durchwegs die gleichen Bedingungen und das Werkstück hat während der Bearbeitung weniger Vibrationen und bewegt sich nicht. Oberfläche und Genauigkeit verbessern sich und sind konstanter.

#### Direct spring loaded stamping jaws

This patented self centering vise is unique, as it can be used for direct stamping the blanks. It is different to others as the teeth bite into the raw material and even under vibrations, one of the two jaws will continuously move forward. This will hold the workpiece with the same force and strength as in the beginning.

The problem in the past was that the other systems in the market were getting loose during heavy machining and accuracy was difficult to achieve.

Especially in soft materials such as alu and soft steels it has a great performance. Usually the workpiece is clamped only 3 mm but this height can be changed from 1,8 to 6 mm if necessary.

Spannkrafterhaltung und Nachfederung  
Spring loaded mechanism to maintain clamping force

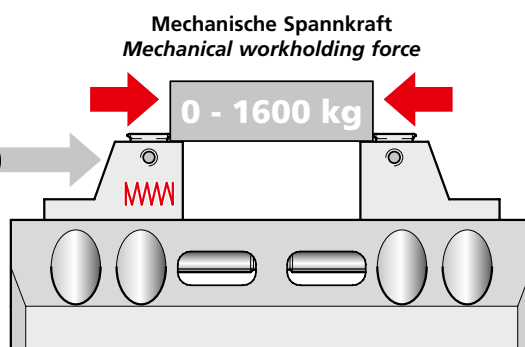

MANF58-14W25 microCLAMP p. 176

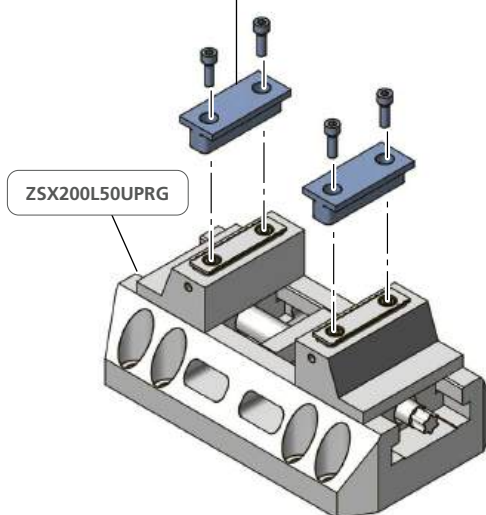

Drehmoment Torque		Spannkraft Workholding force			Gut zu Wissen Good to know
Nm	(lb-ft)	~daN	~(lb)	~t	
10	7,4	= 200	440	0,2	Diese Spannkräfte werden für den Dauerbetrieb empfohlen! These clamping forces are recommended for continuous operation!
20	14,8	= 500	1'102	0,5	
30	22,2	= 1'000	2'204	1,0	
40	29,6	= 1'300	2'866	1,3	
50	37,0	= 1'600	3'527	1,6	
60	44,4	= 1'800	3'968	1,8	Für kurzfristige Anwendung For short-term application
70	51,8	= 2'100	4'629	2,1	

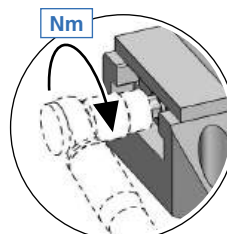

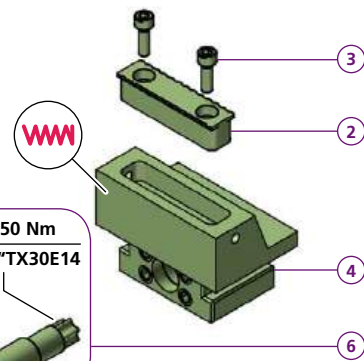
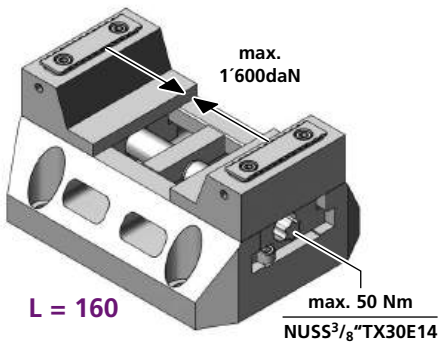
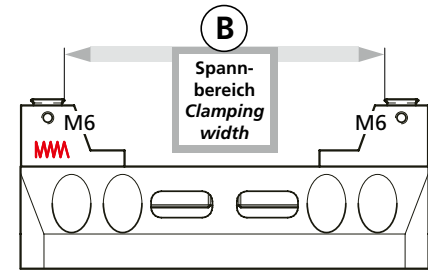
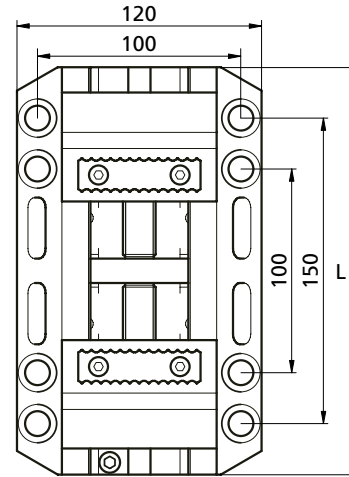
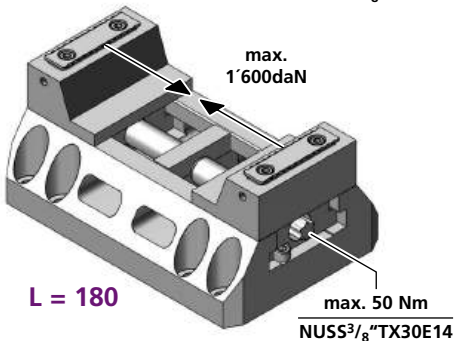
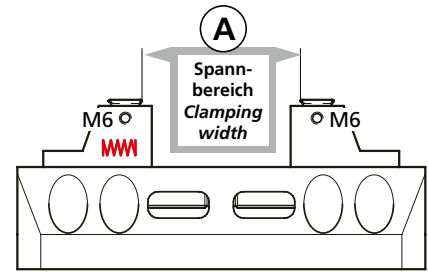
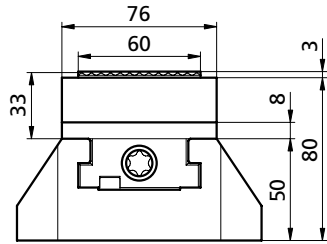
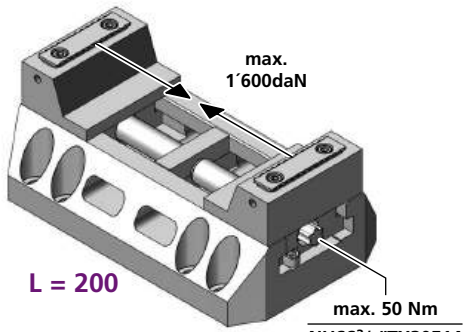

Spannkrafterhaltung und  
Nachfederung  
Spring loaded mechanism  
to maintain clamping force

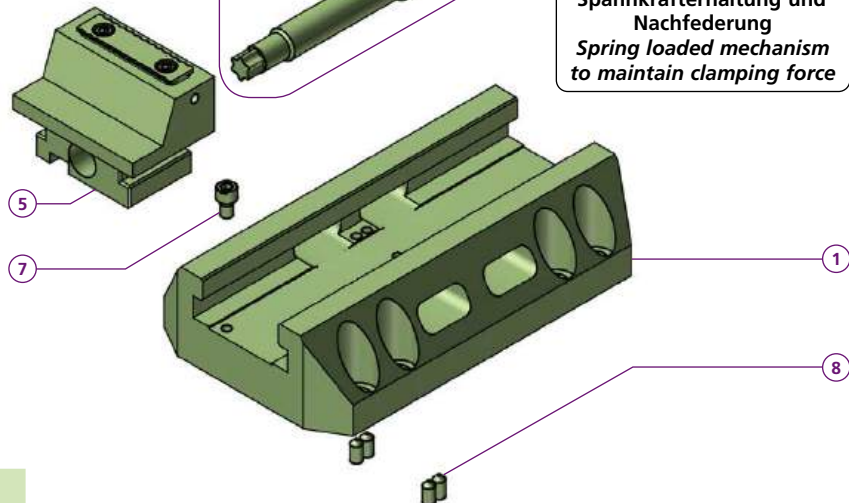
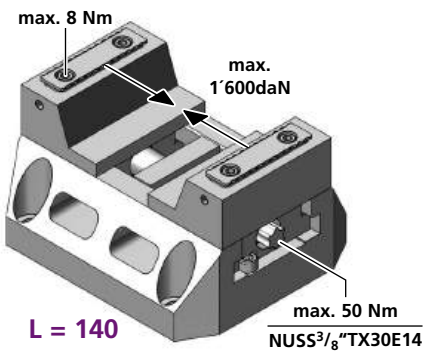

ZSX200L50UPRG	
1	1x TK150025
2	2x MAND58-14PRG
3	4x M5X16ISO4762
4	1x ZB150787
5	1x ZB150786
6	1x PCS16TR200SET
7	1x M6X10ISO4762
8	4x M6X12DIN914
L	= 200
A	10 – 124 mm
B	62 – 178 mm
kg	~8,8

ZSX180L50UPRG	
1	1x TK150523
6	1x PCS16TR180SET
L	= 180
A	10 – 104 mm
B	62 – 158 mm
kg	~8,1

ZSX160L50UPRG	
1	1x TK150522
6	1x PCS16TR160SET
L	= 160
A	10 – 84 mm
B	62 – 138 mm
kg	~7,7

ZSX140L50UPRG	
1	1x TK150521
6	1x PCS16TR140SET
L	= 140
A	10 – 64 mm
B	62 – 118 mm
kg	~7,1

Drehmoment und Spannkraft siehe Seite  
Torque and clamping force see page 140

**NUSS3/8"TX30E14**

**WICHTIG!**  
Bitte separat bestellen  
**IMPORTANT!**  
Please order separately



Bestellbeispiel / Ordering example:  
3 x ZSX200L50UPRG & 1 x NUSS3/8"TX30E14

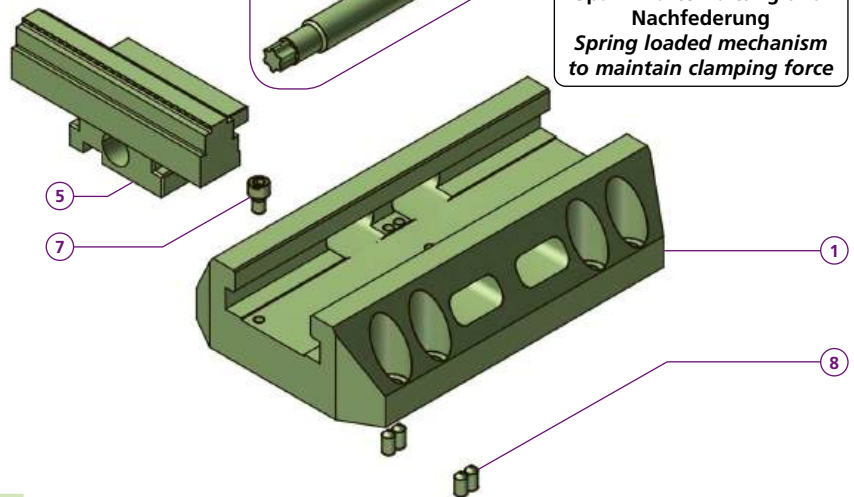
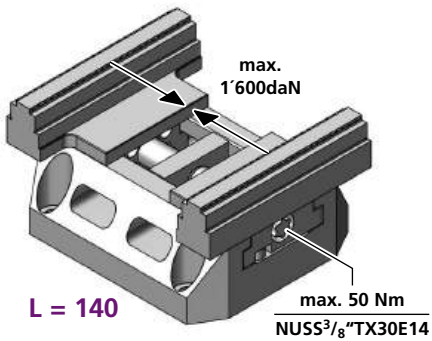
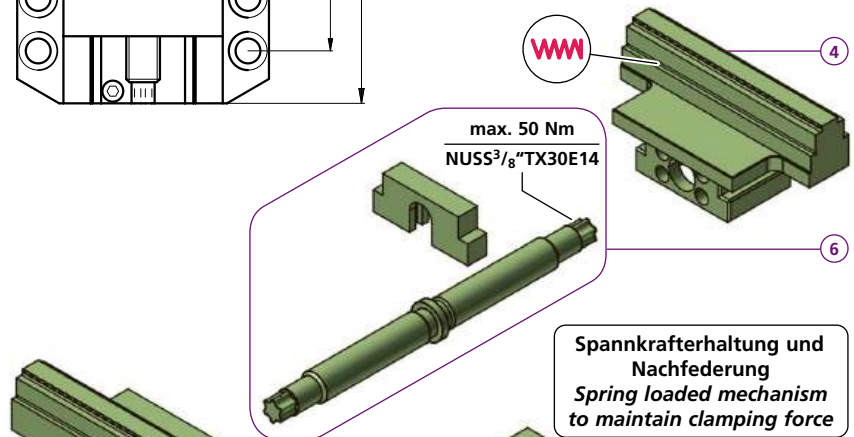
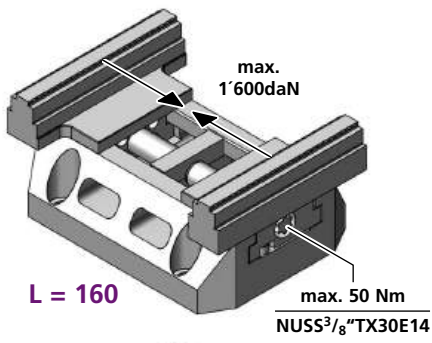
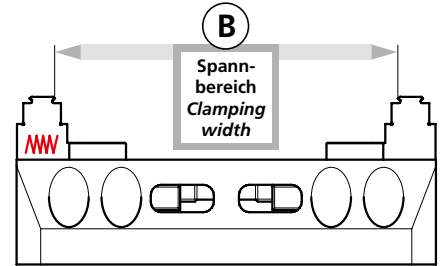
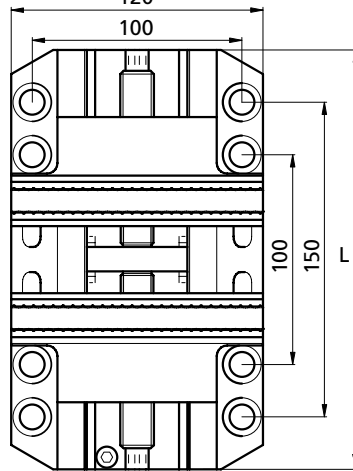
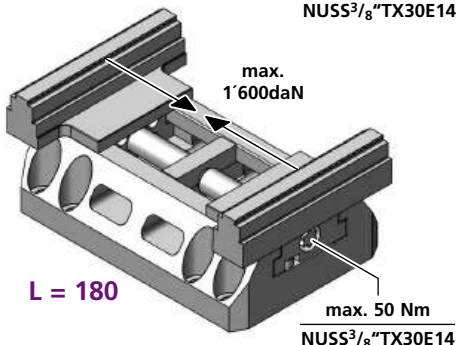
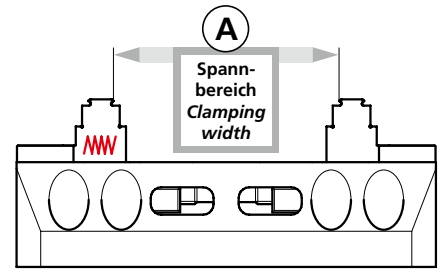
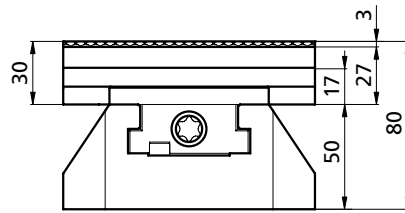
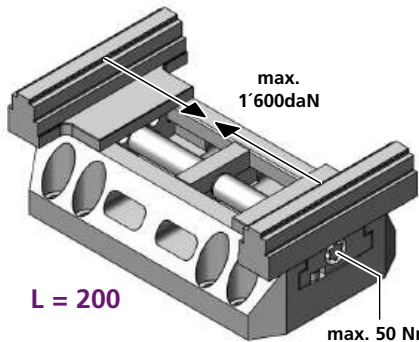

ZSX200L50PRG120	
1	1x TK150025
4	1x ZB170050
5	1x TB170051
6	1x PCS16TR200SET
7	1x M6X10ISO4762
8	4x M6X12DIN914
L	= 200
A	14 – 130 mm
B	70 – 186 mm
kg	~7,7

ZSX180L50PRG120	
1	1x TK150523
6	1x PCS16TR180SET
L	= 180
A	14 – 110 mm
B	70 – 166 mm
kg	~7,2

ZSX160L50PRG120	
1	1x TK150522
6	1x PCS16TR160SET
L	= 160
A	14 – 90 mm
B	70 – 146 mm
kg	~6,6

ZSX140L50PRG120	
1	1x TK150521
6	1x PCS16TR140SET
L	= 140
A	14 – 70 mm
B	70 – 126 mm
kg	~6,0

Drehmoment und Spannkraft siehe Seite 140  
Torque and clamping force see page 140

**NUSS3/8"TX30E14**

**WICHTIG!**  
Bitte separat bestellen  
**IMPORTANT!**  
Please order separately



Bestellbeispiel / Ordering example:  
3 x ZSX200L50PRG120 & 1 x NUSS3/8"TX30E14

Drehmoment Torque		Spannkraft Workholding force			Gut zu Wissen Good to know
Nm	(lb-ft)	~daN	~(lb)	~t	
10	7,4	= 200	440	0,2	Diese Spannkraften werden für den Dauerbetrieb empfohlen! <i>These clamping forces are recommended for continuous operation!</i>
20	14,8	= 500	1'102	0,5	
30	22,2	= 1'000	2'204	1,0	
40	29,6	= 1'300	2'866	1,3	
50	37,0	= 1'600	3'527	1,6	
60	44,4	= 1'800	3'968	1,8	Für kurzfristige Anwendung <i>For short-term application</i>
70	51,8	= 2'100	4'629	2,1	

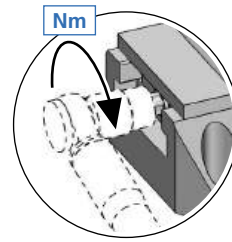

NEWS →

PowerCLAMP

Anschlagmodul mit Prägeeinsätzen  
End modul with embossed inserts

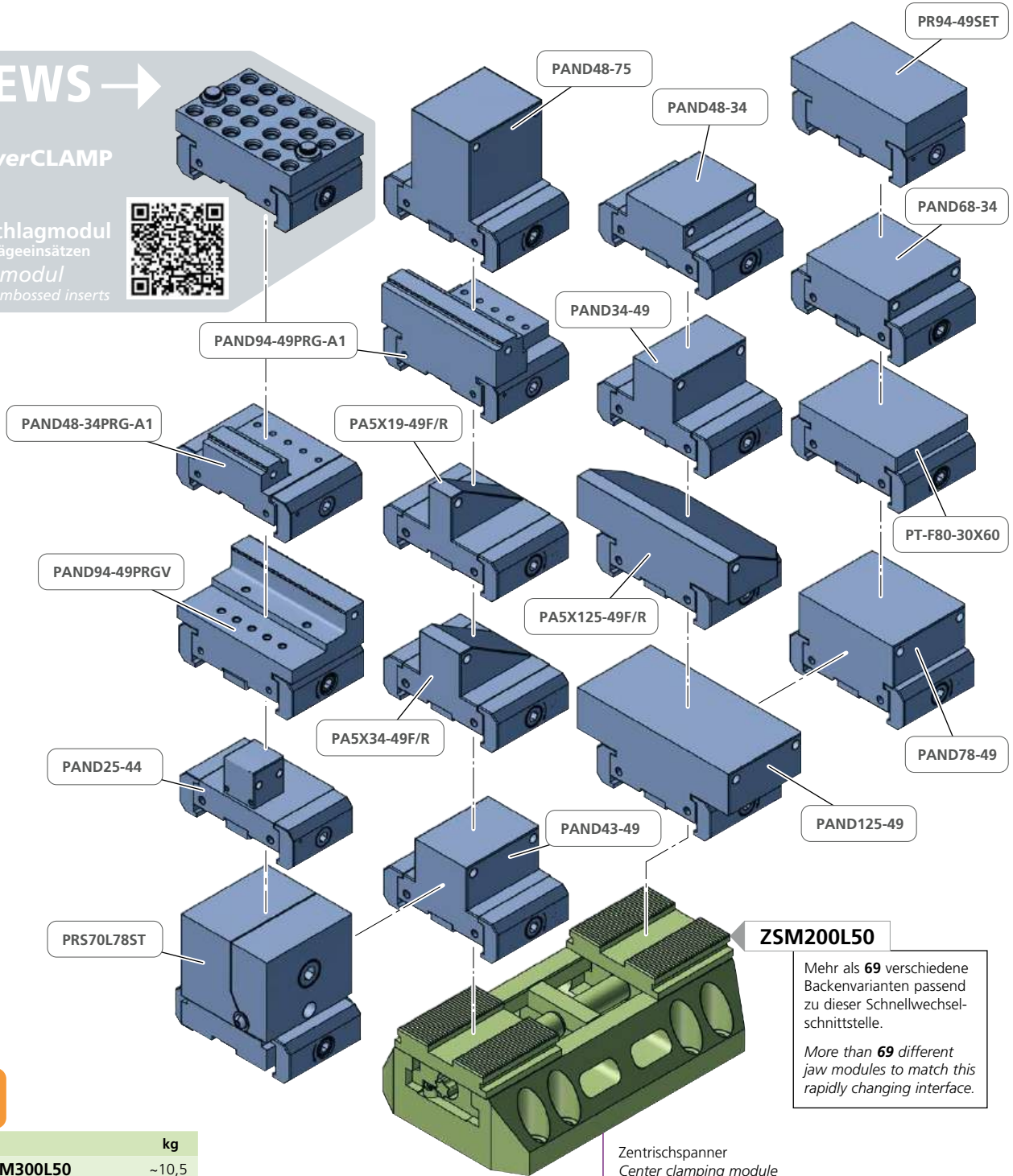

ZSM200L50

Mehr als 69 verschiedene Backenvarianten passend zu dieser Schnellwechelschnittstelle.

More than 69 different jaw modules to match this rapidly changing interface.

Zentrischspanner  
Center clamping module



	kg
ZSM300L50	~10,5
1 ZSM200L50	~7,4
ZSM180L50	~6,9
ZSM160L50	~6,4
ZSM140L50	~5,7
2x	

powerCLAMP p. 86 - 96

Bestellbeispiel / Ordering example: 1 x ZSM200L50 & 2 x PAND94-49PRG-A1

# Zentrischspanner mit powerCLAMP Schnittstelle

## Self centering vise with powerCLAMP interface

Art. Nr.	A	B	kg	L
<b>ZSM140L50</b>	60 – 120 mm	10 – 68 mm	~5,7	140
<b>ZSM160L50</b>	60 – 140 mm	10 – 88 mm	~6,4	160
<b>ZSM180L50</b>	60 – 160 mm	10 – 108 mm	~6,9	180
<b>ZSM200L50</b>	60 – 180 mm	10 – 128 mm	~7,4	200
<b>ZSM300L50</b>	60 – 280 mm	10 – 228 mm	~10,5	300



Werkstückauflage  
Workpiece supports

PAND94-34PRGV

ZSM300L50

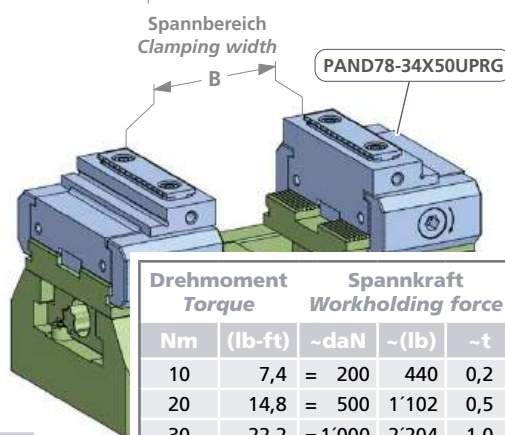
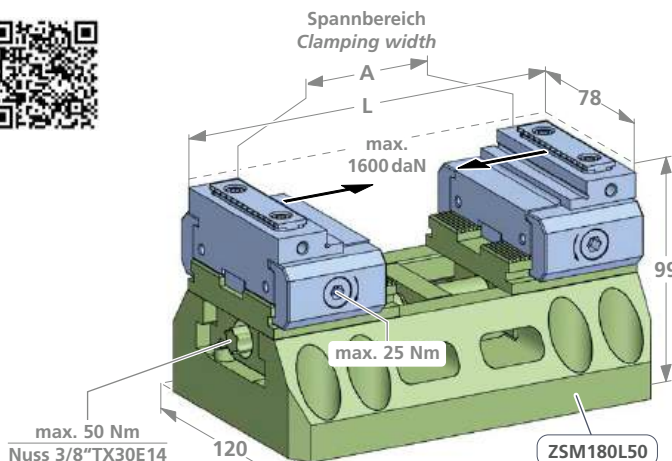

Drehmoment Torque		Spannkraft Workholding force		
Nm	(lb-ft)	~daN	~(lb)	~t
10	7,4	= 200	440	0,2
20	14,8	= 500	1'102	0,5
30	22,2	= 1'000	2'204	1,0
40	29,6	= 1'300	2'866	1,3
50	37,0	= 1'600	3'527	1,6

Mehr als 60 verschiedene Backenvarianten passend zu dieser Schnellwechselschnittstelle.  
 More than 60 different jaw modules to match this rapidly changing interface.

### NUSS3/8"TX30E14

**WICHTIG!**  
 Bitte separat bestellen  
**IMPORTANT!**  
 Please order separately

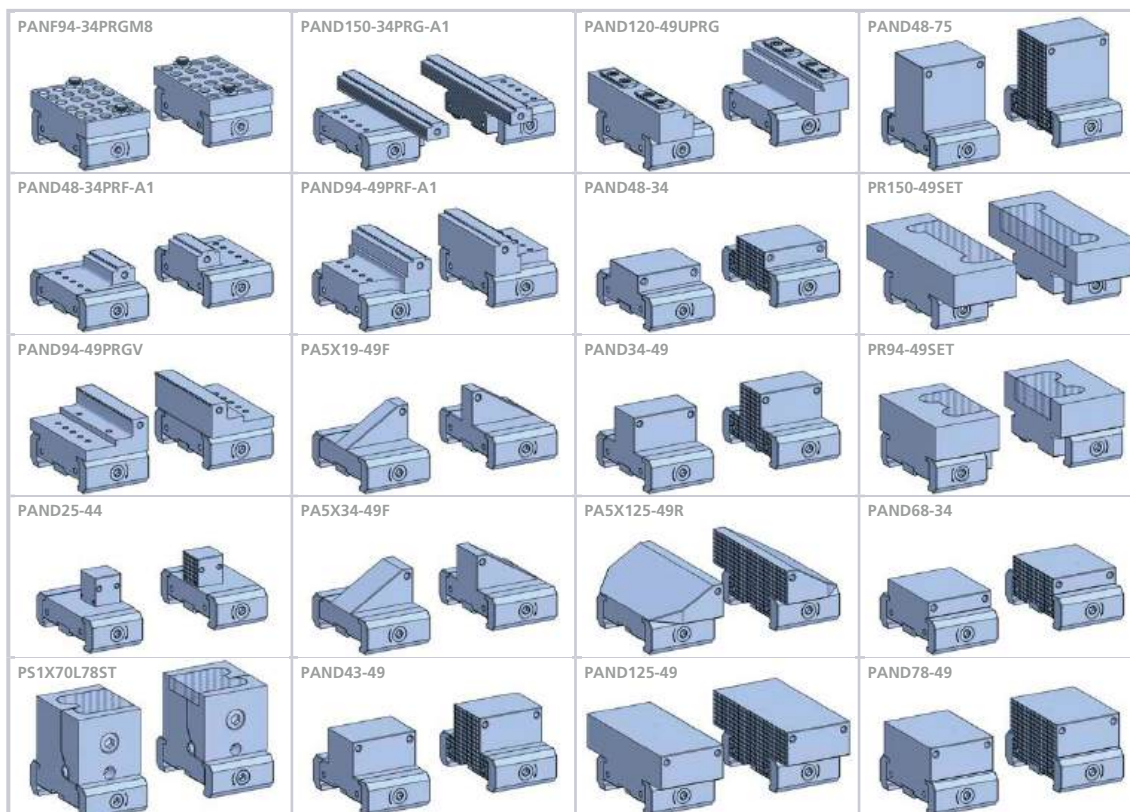

**Seitlich verstellbarer Zentrischspannstock**

Passend auf alle Power Clamp Basisschienen können mehrere dieser Zentrischspanner, seitlich aneinander gereiht, lange Werkstücke spannen und sind dabei flexibel in 2 mm Schritten seitlich verschiebbar.

Auch können diese für Mehrfachspannung genutzt werden und mehrere Einzelteile an fixen Punkten gespannt werden.

Einsatzgebiet für lange Profile, Stangen und Bleche aber auch Mehrfachspannung von fast allen Materialien.

**Laterally adjustable centric vise**

Fitting all Power Clamp basic rails, several of these self-centering vices can, arranged laterally in rows, clamp long work pieces and can hereby be flexibly shifted sideways in 2 mm steps.

They can also be used for multi clamping and several individual parts clamped at fixed points.

The field of application for long sections, rods and sheets but also multi clamping of almost all materials.

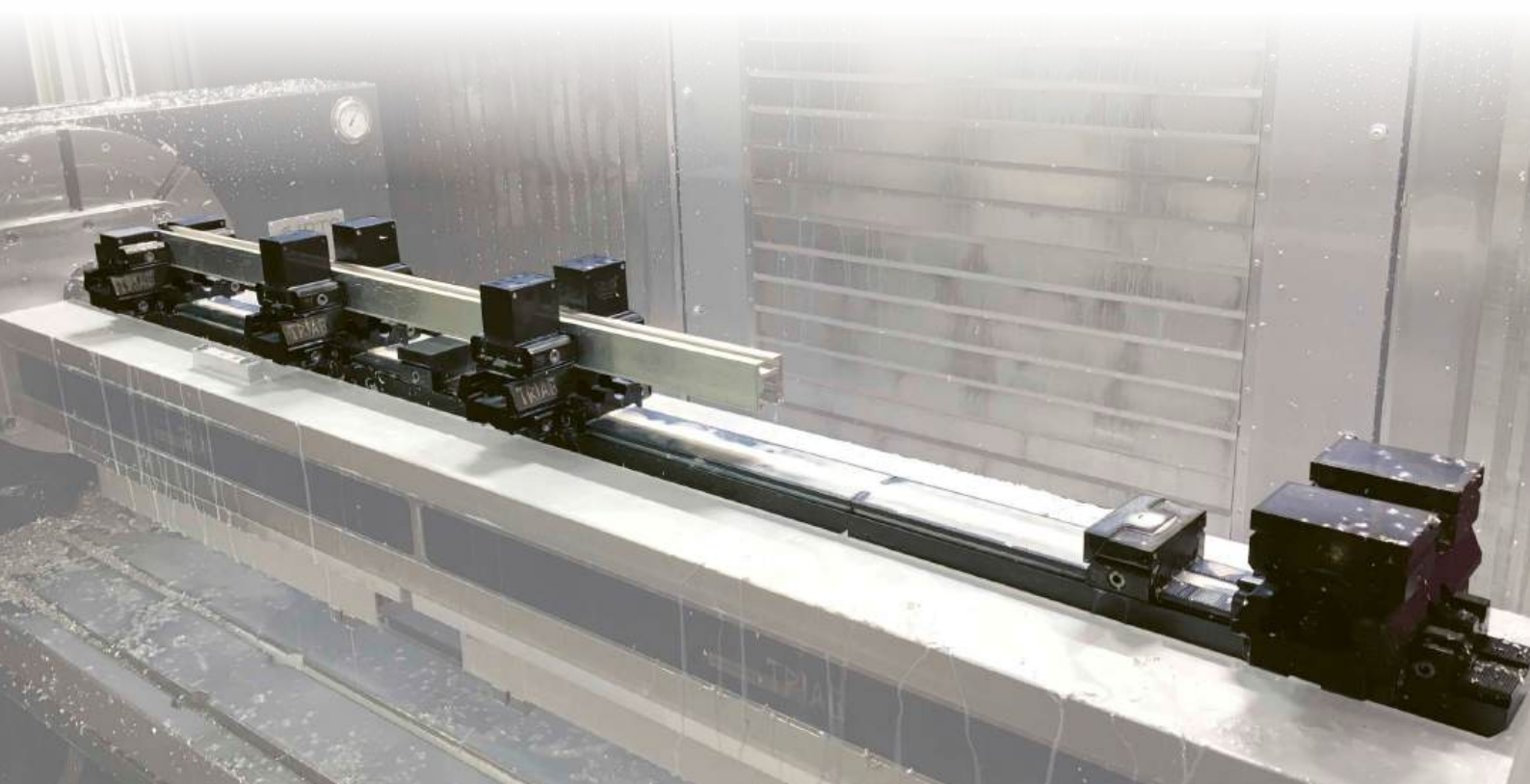
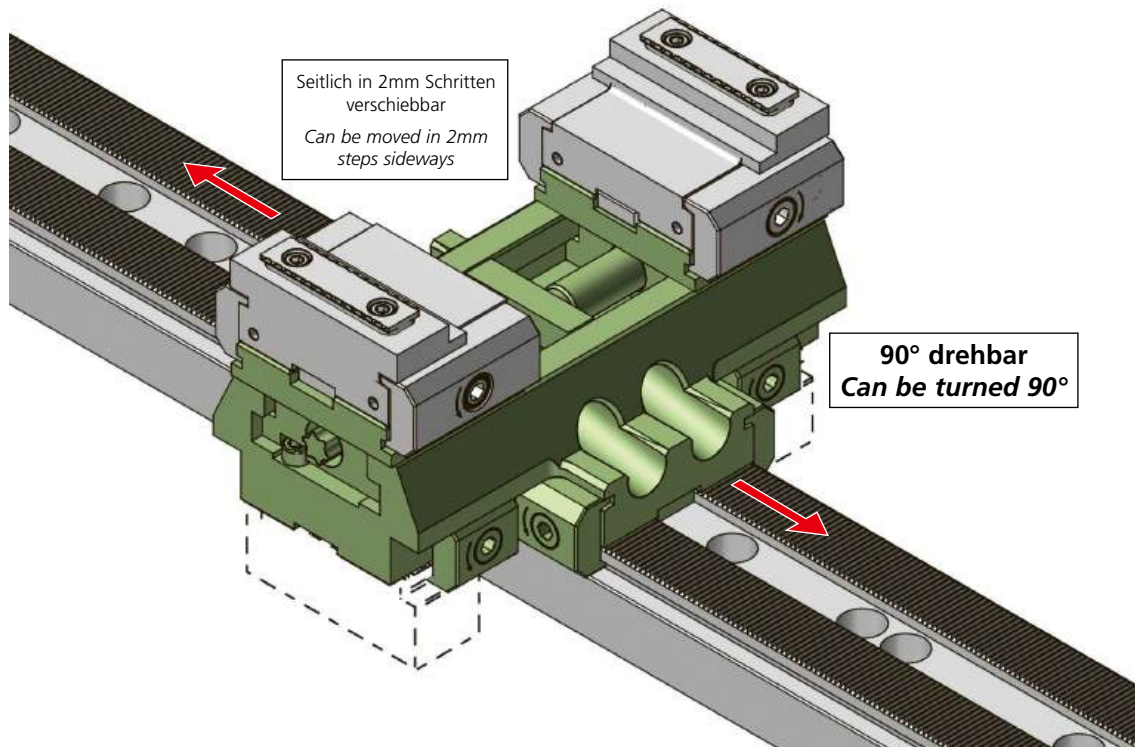

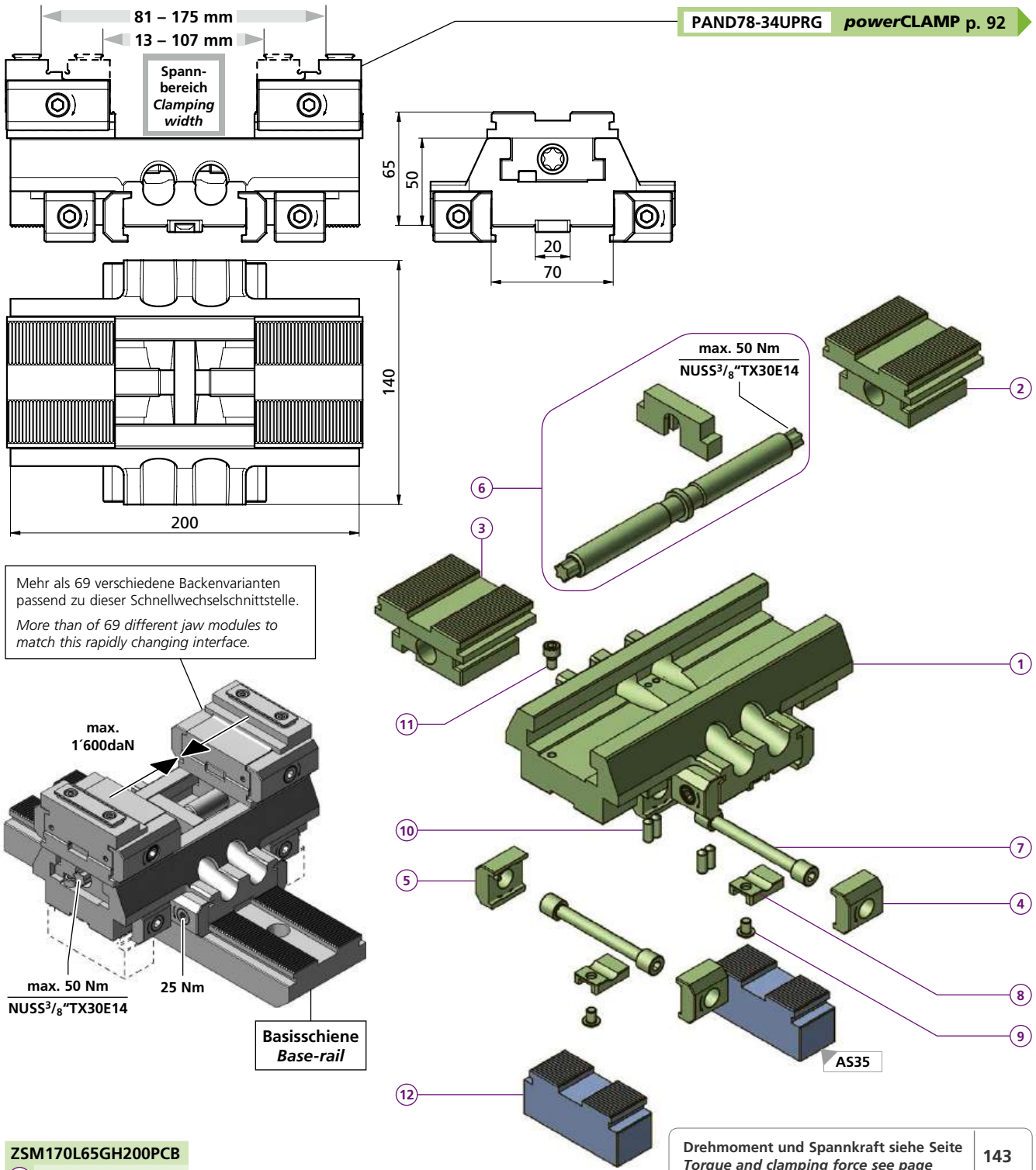

ZSM170L65GH200PCB

- ① 1x TB140566
- ② 1x TB150092
- ③ 1x TB150091
- ④ 4x PCSP30L
- ⑤ 4x PCSP30R
- ⑥ 1x PCS16TR200SET
- ⑦ 4x PCS14
- ⑧ 4x PCGU2030
- ⑨ 4x M6X8ISO7380
- ⑩ 4x M6X12DIN914
- ⑪ 1x M6X10ISO4762
- ⑫ 2x

kg ~8,6

Schienenhöhe / Rail height

AS35	kg	AS60	kg	AS80	kg
(H = 35)	~0,6	(H = 60)	~1,1	(H = 80)	~1,5

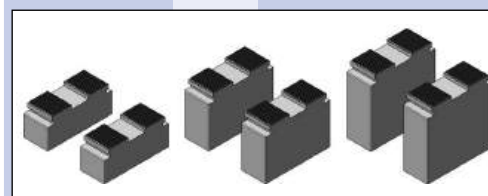

NUSS3/8“TX30E14

**WICHTIG!**  
Bitte separat bestellen  
**IMPORTANT!**  
Please order separately



Seitliche Stützen

Bei Gebrauch der Querschienen 90°, werden je nach Höhe der Basisschiene auf dessen sie aufgesetzt sind, zwei seitliche Stützen AS35 / AS60 / AS80 unterlegt.

Side support

When using the cross rail 90°, a side support AS35 / AS60 / AS80 is underlaid, depending on the height of the base rail on which it is placed.

Bestellbeispiel / Ordering example: 2 x ZSM170L65GH200PCB & 4 x AS35 & 1 x NUSS3/8“TX30E14

Separat bestellen / Order separately

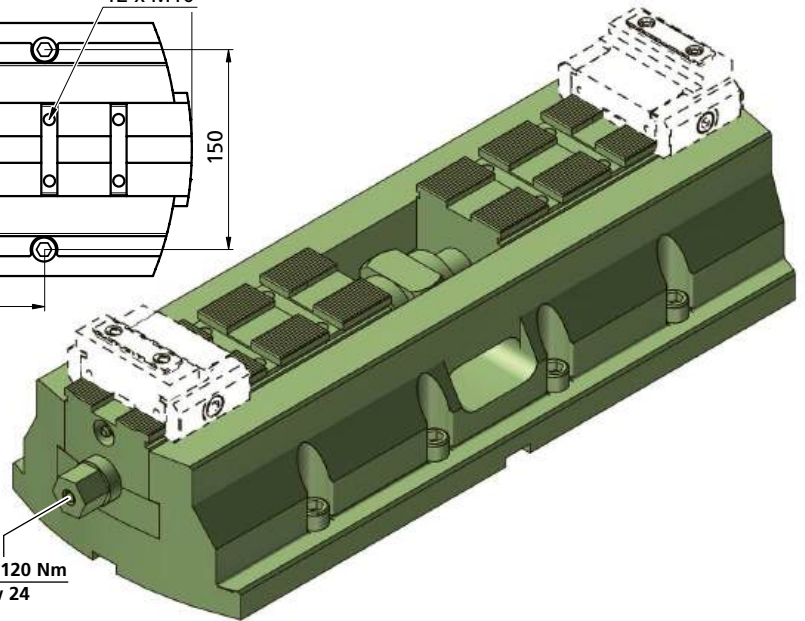
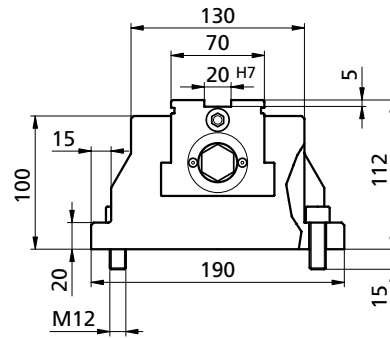
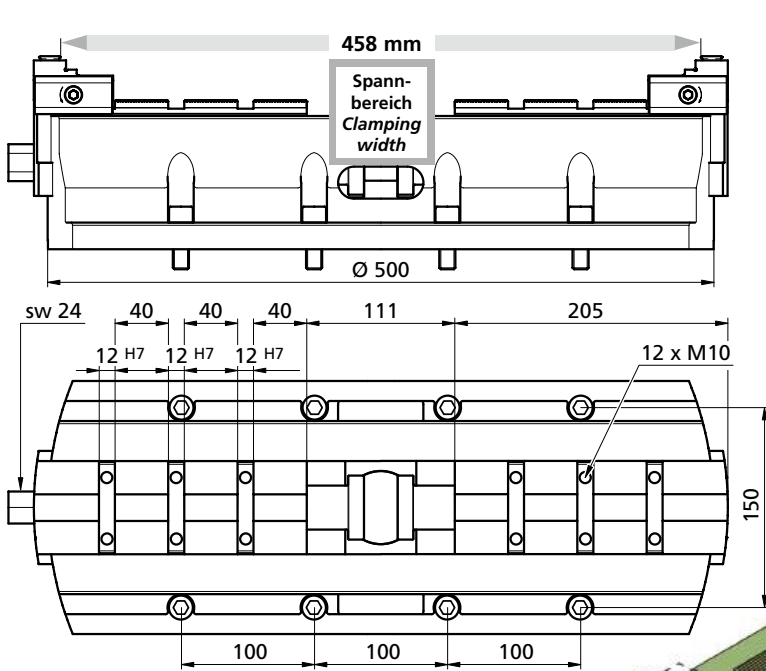

**ZSMB500L112** kg = ~59  
**Backenhub (pro Backe)**  
**Stroke of clamping (each jaw)**  
 55 mm

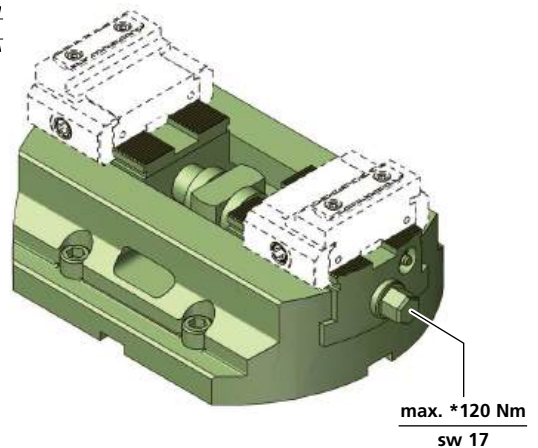
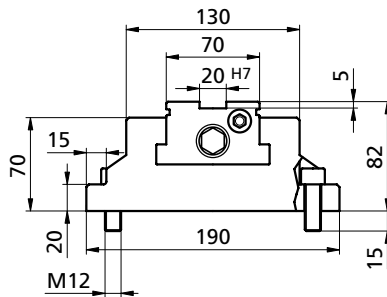
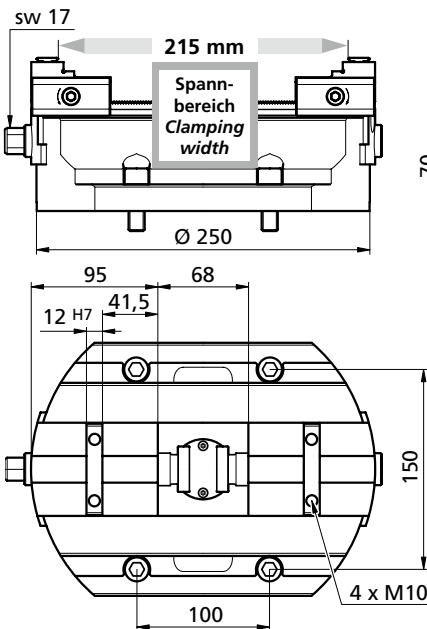

**ZSMB250L82** kg = ~19  
**Backenhub (pro Backe)**  
**Stroke of clamping (each jaw)**  
 35 mm

Drehmoment Torque		Spannkraft Workholding force			<p><b>Gut zu Wissen</b>  <b>Good to know</b></p> <p>Diese Spannkraften werden für den Dauerbetrieb empfohlen!                      These clamping forces are recommended for continuous operation!</p> <p>Für kurzfristige Anwendung                      For short-term application</p>
Nm	(lb-ft)	~daN	~(lb)	~t	
40	29,5	= 800	1798	0,8	
60	44,26	= 1200	2697	1,2	
80	59	= 1600	3597	1,6	
100	73,75	= 2000	4496	2	
*120	88,5	= 2400	5395	2,4	

**!** Für längerfristige Anwendung ab 140 – 250 Nm müssen **geschraubte Backen** eingesetzt werden!  
 For longer-term use from 140 – 250 Nm the **screwed jaws** must be used!

Bestellbeispiel / Ordering example : **ZSMB500L112**

# Zentrischspanner mit Schnellwechselbacken

## Self centering vise with quick-change jaws

### Zentrischspanner mit Spannkrafterhaltung und Nachfederung

#### Self centering vise with spring loaded mechanism to maintain clamping force

Art. Nr.	WW	A mm	B mm	C mm		kg
ZSQ300L50UPRG	80 – 260			8 – 188		~11,10
ZSQP300L50UPRG	80 – 260			8 – 188	$\pm 3^\circ$	~11,10
ZSQ200L50UPRG	80 – 160	44 – 124		8 – 88		~8,1
ZSQP200L50UPRG	80 – 160	44 – 124		8 – 88	$\pm 3^\circ$	~8,1
ZSQ180L50UPRG	80 – 140	44 – 104		8 – 68		~7,55
ZSQP180L50UPRG	80 – 140	44 – 104		8 – 68	$\pm 3^\circ$	~7,5
ZSQ160L50UPRG	80 – 120	44 – 84		8 – 48		~7,1
ZSQP160L50UPRG	80 – 120	44 – 84		8 – 48	$\pm 3^\circ$	~7,0

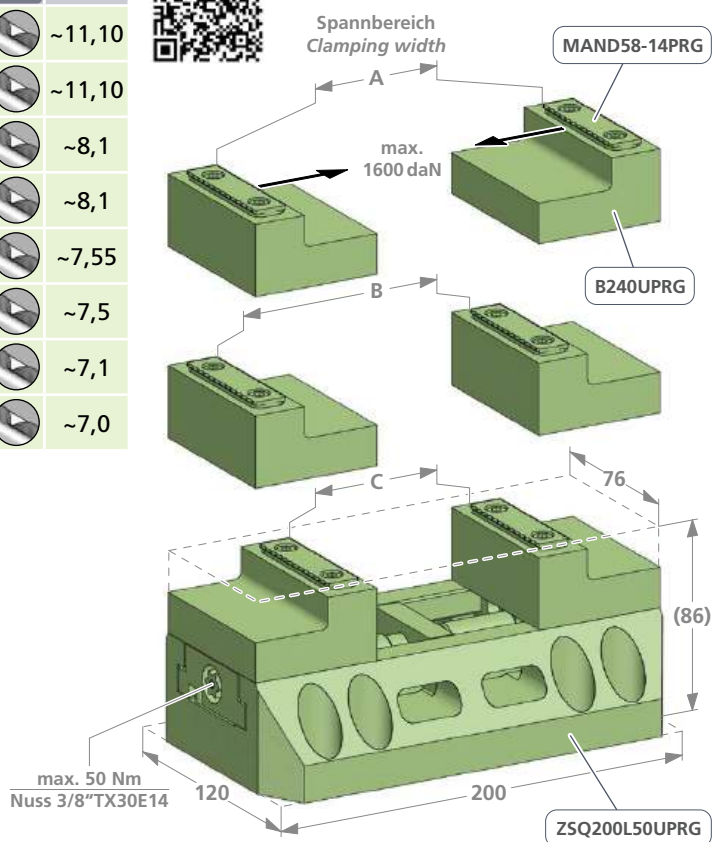

Für die Montage der Backen B240UPRG wird kein Werkzeug benötigt, diese werden per Hand auf dem Spanner eingeklinkt.

No tools are required for mounting the B240UPRG jaws, which are clipped onto the clamp by hand.

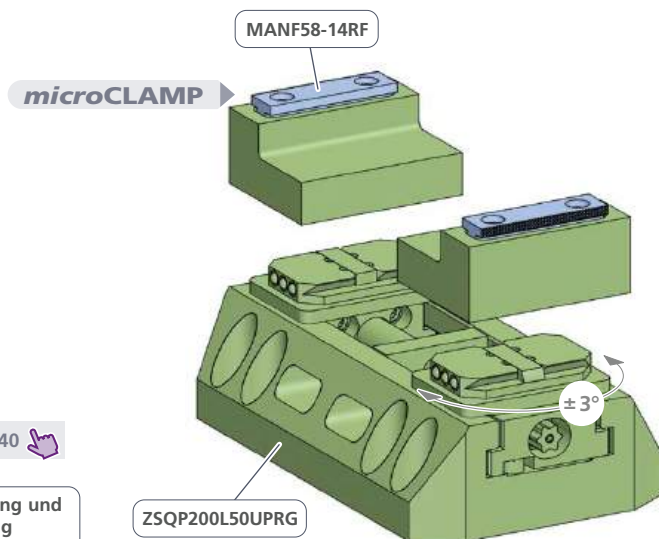

Drehmoment Torque		Spannkraft Workholding force		
Nm	(lb-ft)	~daN	~(lb)	~t
10	7,4	= 200	440	0,2
20	14,8	= 500	1'102	0,5
30	22,2	= 1'000	2'204	1,0
40	29,6	= 1'300	2'866	1,3
50	37,0	= 1'600	3'527	1,6

**NUSS3/8"TX30E14**

**WICHTIG!**  
Bitte separat bestellen

**IMPORTANT!**  
Please order separately

# Zentrischspanner mit Schnellwechselbacken

## Self centering vise with quick-change jaws

Typ **Q**

triCENTRO



ZSQ300L50UPRG

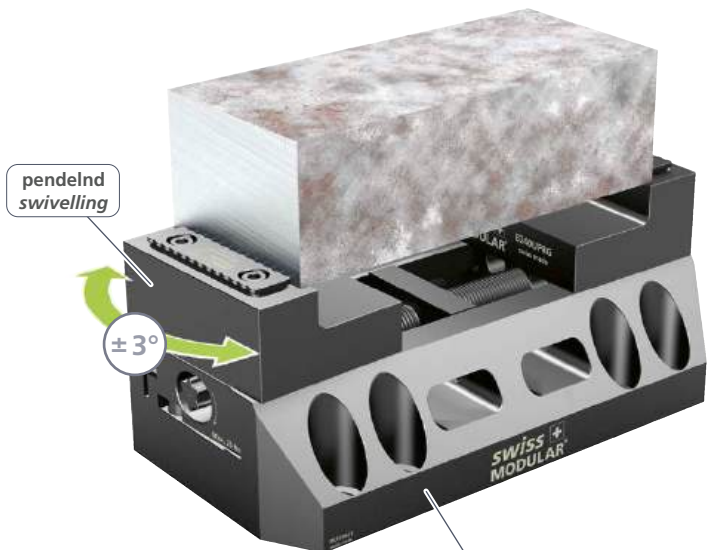

pendelnd  
swivelling

±3°

ZSQ200L50UPRG

Mit diesen Zentrischspannern sind Ihre Werkstücke in festem Griff.  
With these self centering vises your workpieces are in a firm grip.

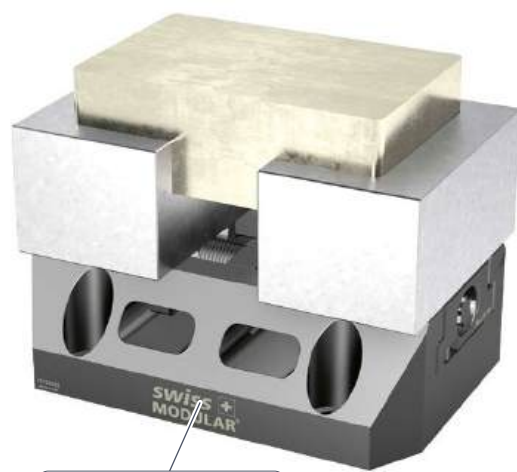

ZSQ160L50 / B242W50-100

### Spannbacke / Clamping jaw

Art. Nr.	B242W50-100	B240UPRG
	Vergütungsstahl Tempering steel (1.7225)	57HRC
<b>kg</b>	~2	~0,52

Weich, zur Herstellung individueller Formbacken. / Soft, for the production of individual moulding jaw.

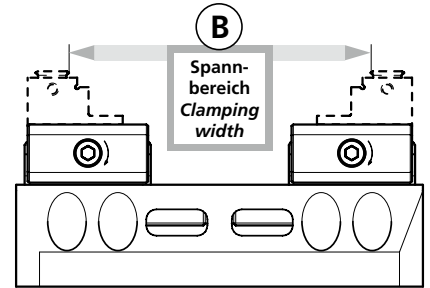
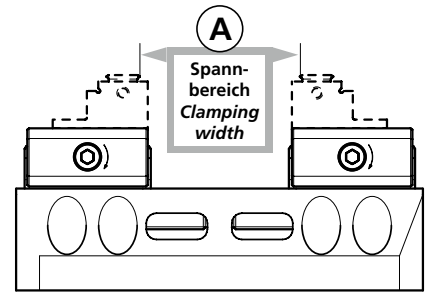
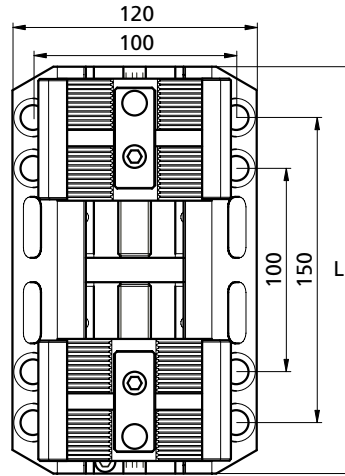
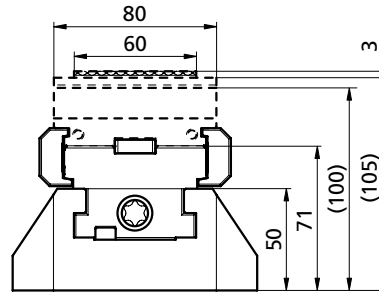
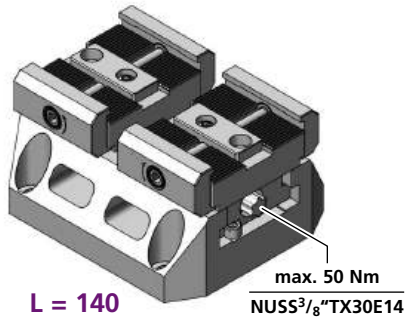
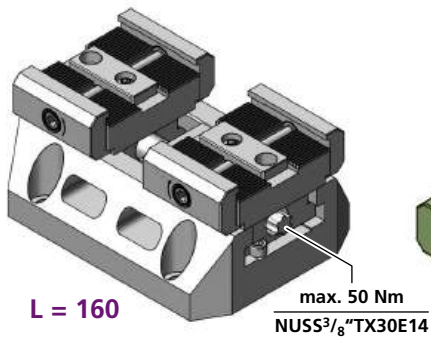
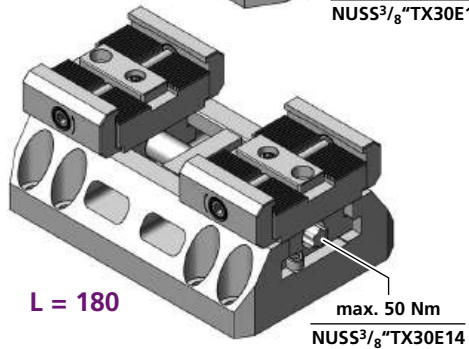
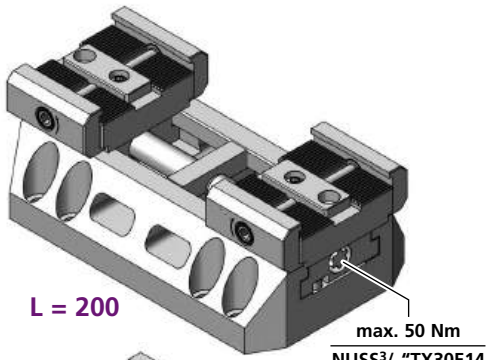

PCZB8050UPRG p. 152

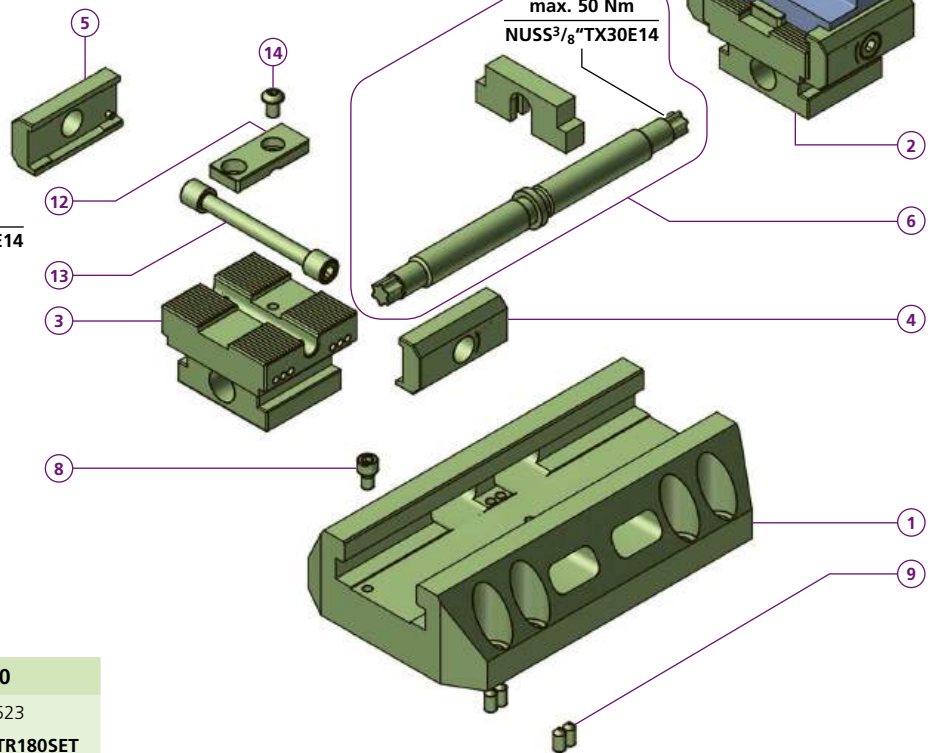

**ZSB200L50**

1	1x TK150025
2	1x ZB150791
3	1x ZB150792
4	2x PCSP60RG
5	2x PCSP60LG
6	1x PCS16TR200SET
8	1x M6X10ISO4762
9	4x M6X16DIN914
12	2x PCGU2049
13	2x PCS14
14	2x M6X8ISO7380
L	= 200
A	10 – 126 mm
B	58 – 174 mm
kg	~8,4

**ZSB180L50**

1	1x TK150523
6	1x PCS16TR180SET
L	= 180
A	10 – 104 mm
B	58 – 154 mm
kg	~7,9

**ZSB160L50**

1	1x TK150522
6	1x PCS16TR160SET
L	= 160
A	10 – 86 mm
B	58 – 134 mm
kg	~7,4

**ZSB140L50**

1	1x TK150521
6	1x PCS16TR140SET
L	= 140
A	10 – 65 mm
B	58 – 113 mm
kg	~6,7

Drehmoment und Spannkraft siehe Seite 151  
Torque and clamping force see page 151

**NUSS<sup>3/8</sup>"TX30E14**

**WICHTIG!**  
Bitte separat bestellen  
**IMPORTANT!**  
Please order separately



Bestellbeispiel / Ordering example: 3 x ZSB200L50 & 6 x PCZB8050UPRG & 1 x NUSS<sup>3/8</sup>"TX30E14

Drehmoment Torque		Spannkraft Workholding force			Gut zu Wissen Good to know
Nm	(lb-ft)	~daN	~(lb)	~t	
10	7,4	= 200	440	0,2	Diese Spannkraften werden für den Dauerbetrieb empfohlen! <i>These clamping forces are recommended for continuous operation!</i>
20	14,8	= 500	1'102	0,5	
30	22,2	= 1'000	2'204	1,0	
40	29,6	= 1'300	2'866	1,3	
50	37,0	= 1'600	3'527	1,6	
60	44,4	= 1'800	3'968	1,8	Für kurzfristige Anwendung <i>For short-term application</i>
70	51,8	= 2'100	4'629	2,1	

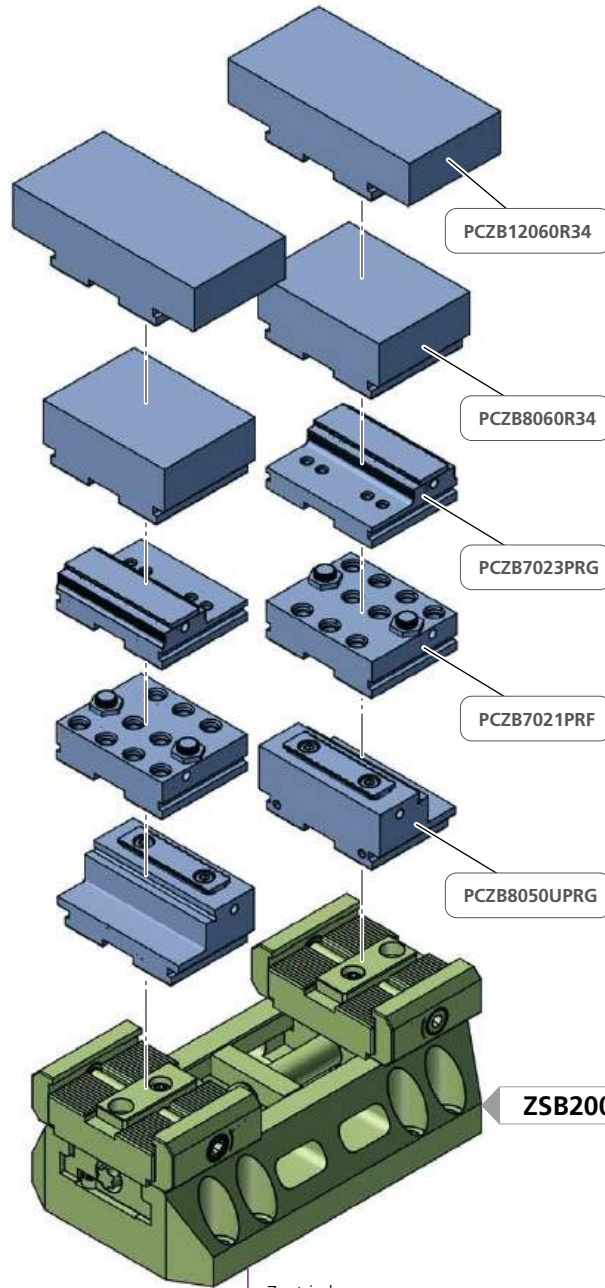
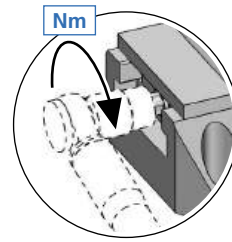

PCZB12060R34

PCZB8060R34

PCZB7023PRG

PCZB7021PRF

PCZB8050UPRG

ZSB200L50

Mehr als **8** verschiedene Backenvarianten passend zu dieser Schnellwechelschnittstelle.  
*More than **8** different jaw modules to match this rapidly changing interface.*

Zentrischspanner  
Center clamping module

①

**B**

	kg
① ZSB200L50	~8,4
ZSB180L50	~7,9
ZSB160L50	~7,4
ZSB140L50	~6,7
2x	

p. 152

Bestellbeispiel / Ordering example: 1 x ZSM200L50 & 2 x PCZB8050UPRG

Separat bestellen / Order separately

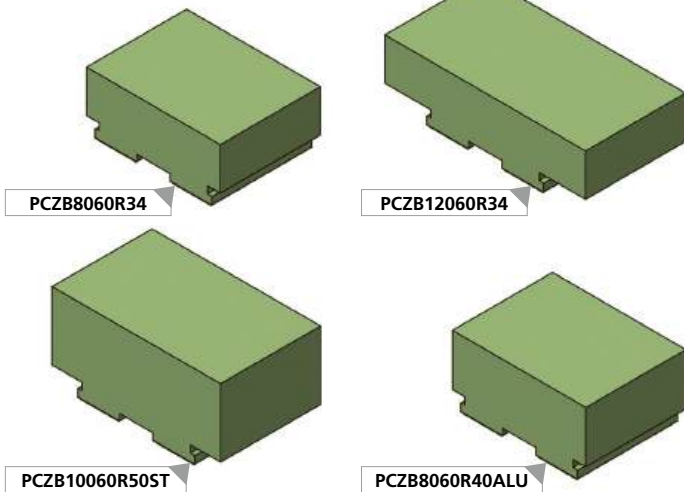
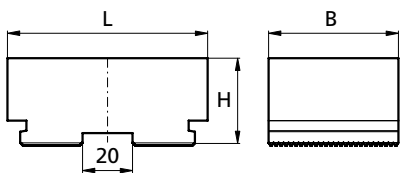

		L	B	H	kg
<b>PCZB8060R34</b>	(Stahl/Steel)	80	60	34	~1,2
<b>PCZB12060R34</b>	(Stahl/Steel)	120	60	34	~1,7
<b>PCZB10060R50ST</b>	(Stahl/Steel)	101	60	50	~2,2
<b>PCZB8060R40ALU</b>	ALU	80	60	40	~0,52
<b>PCZB10060R50</b>	ALU	101	60	50	~0,76

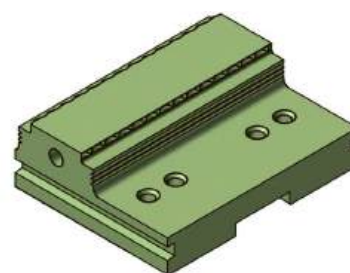
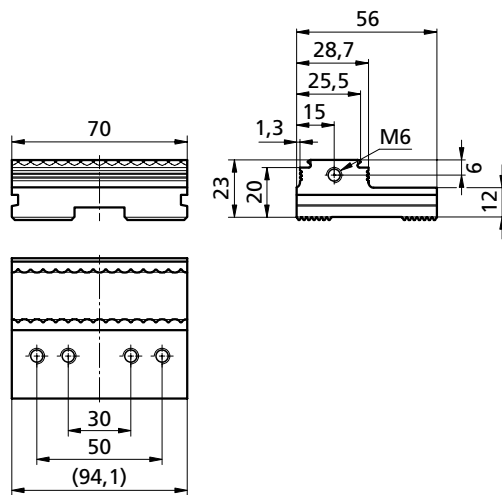

**PCZB7023PRG** kg ~0,54

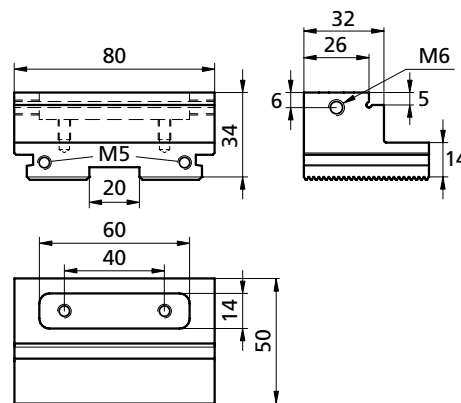
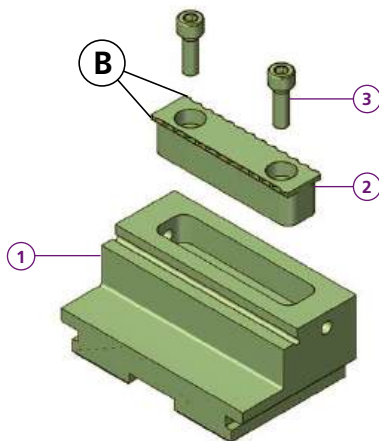

**PCZB8050UPRG**

- ① 1x TB161200
  - ② 1x MAND58-14PRG
  - ③ 1x M5X16ISO4762
- kg ~0,75

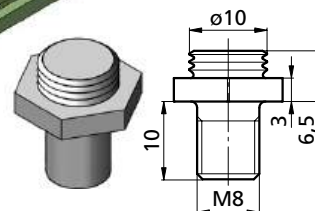
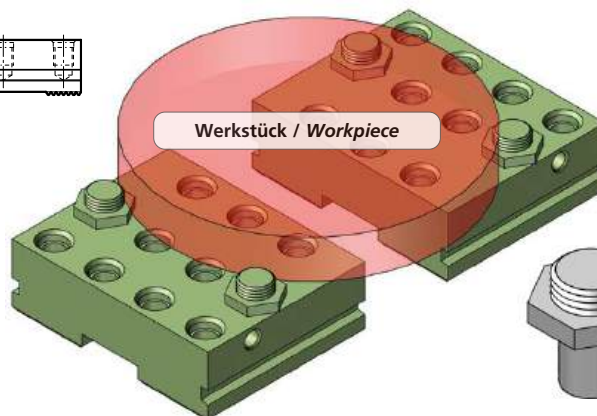
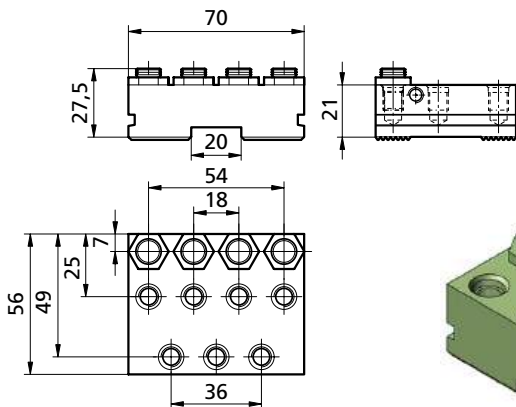

**PCZB7021PRF** kg ~0,6

**PRG1003M8**

Bestellbeispiel / Ordering example: 2 x **PCZB7021PRF** & 4 x **PRG1003M8**

**spaceGRIP III**

Spannbereich bis 180 mm, Spannkraft bei 70 Nm, 2,1 t/2100 daN. Hier kommen die «Grossen» unserer Zentrischspanner zum Einsatz. Speziell ist der Aufbau auf einer Stahl-Mineralgusspyramide um beste Verhältnisse bezüglich Vibrationsdämpfung zu bieten. Die Zentrischspanner dazu gibt es in vier Gehäuselängen (140, 160, 180 und 200 mm) und bis zu 60 Backenvarianten.

**spaceGRIP III**

*Spans of up to 180 mm, clamping force at 70 Nm, 2.1 t/2100 daN. Here the «big ones» of our self-centering vices go into action. And there is the special setup of a steel mineral casting pyramid to provide the best conditions for vibration dampening. The self-centering vice for this is available with four housing lengths (140, 160, 180 and 200 mm) and up to 60 jaw versions.*

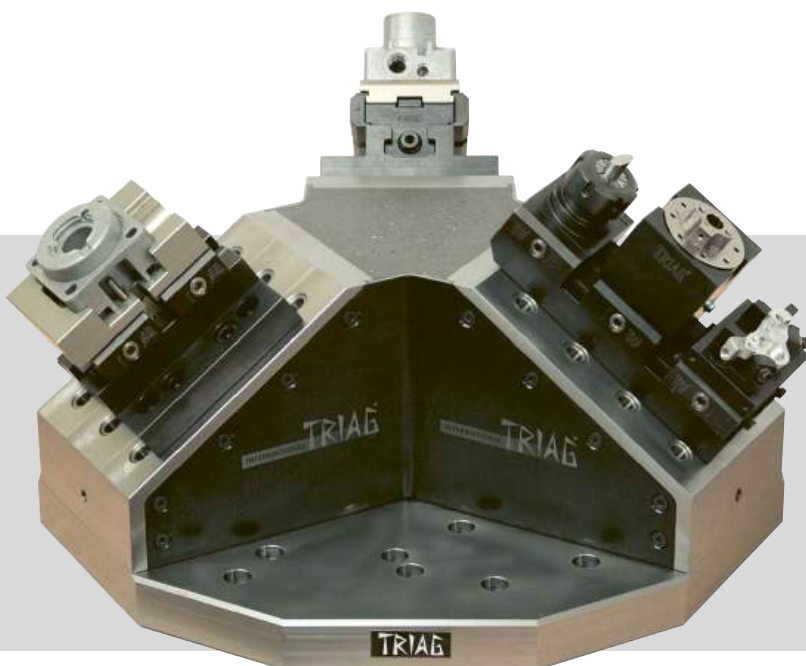

**SPACEGRIP III**

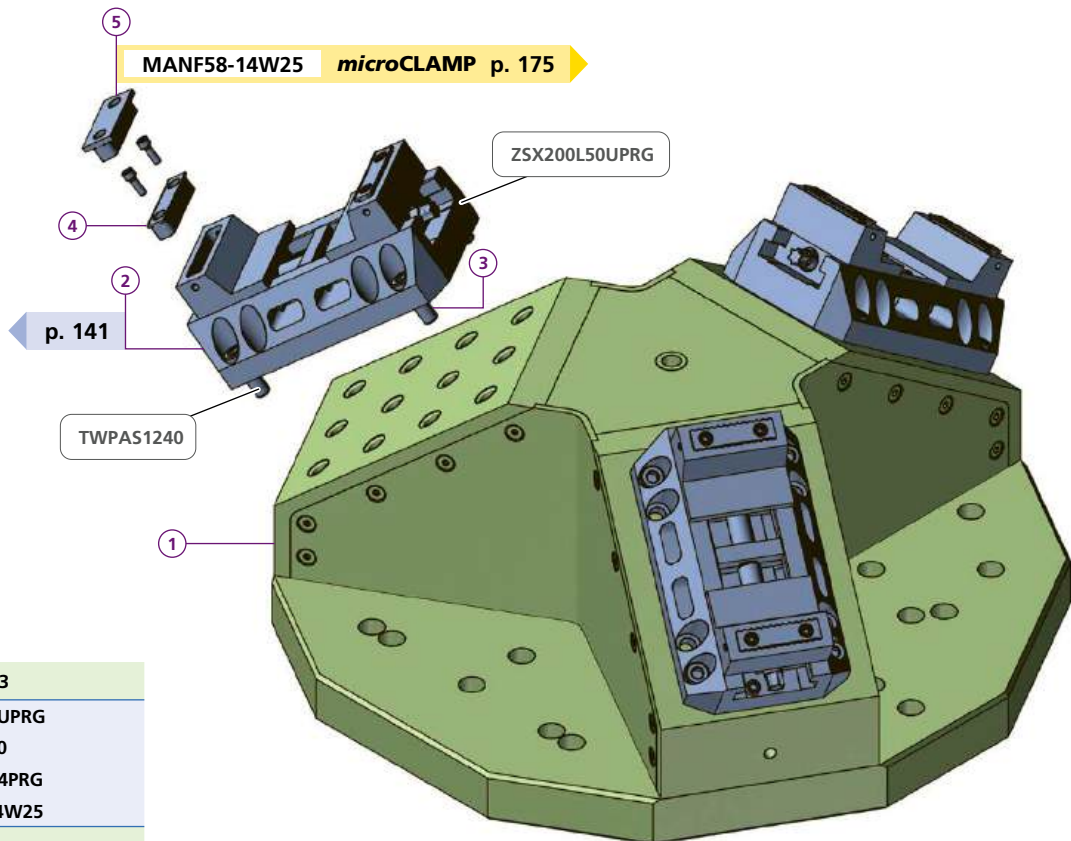
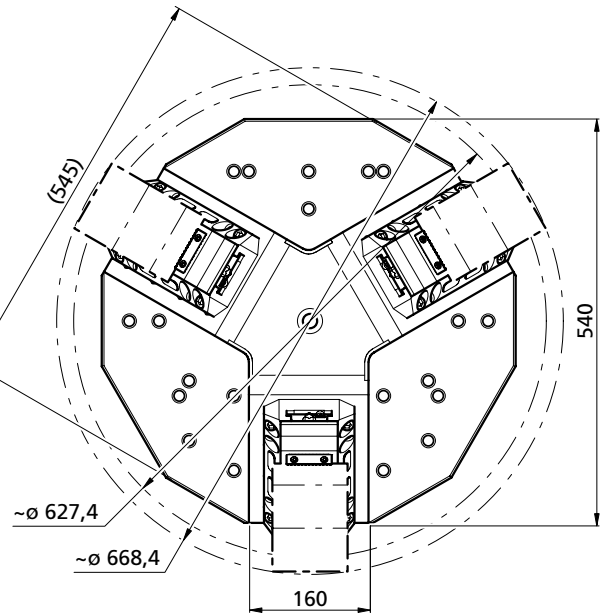
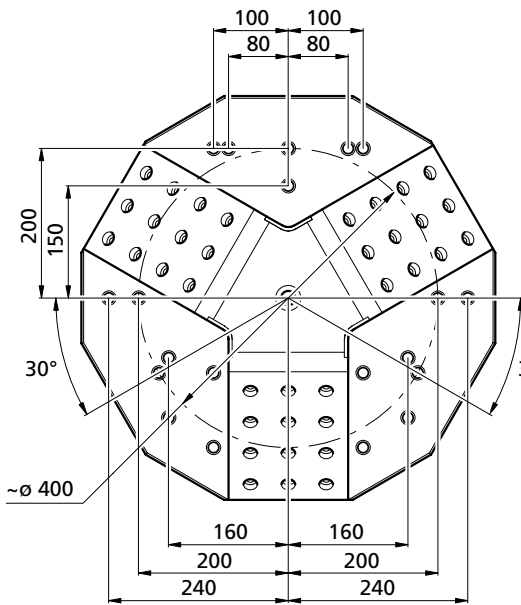
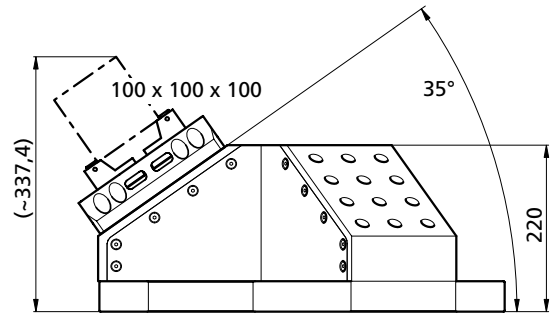
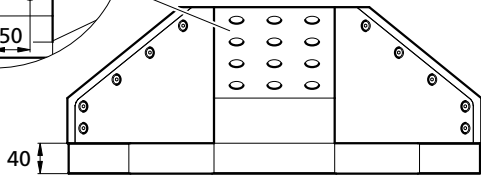
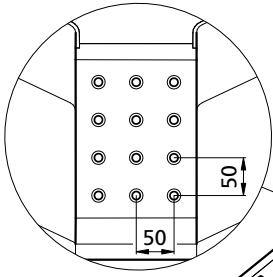

1	1x	5AXZSX35-3
2	3x	ZSX200L50UPRG
3	12x	TWPAS1240
4	6x	MANF58-14PRG
5	6x	MANF58-14W25
kg		~135

Bestellbeispiel / Ordering example: 1 x 5AXZSX35-3 & 3 x ZSX200L50UPRG & 6 x MANF58-14W25

Separat bestellen / Order separately



Zwei pneumatische Zentrischspanner auf einer Spannbrücke und Fanuc Robodrill.  
Über 100 verschiedene Standardbacken in Sekundenschnelle wechseln.  
*Two pneumatic self centering vise on a Fanuc robodrill machining center.  
From more than 100 different standard jaw modules can be changed in a view second.*

ZSP40L38SET-ZO



ZSP125L85-1



ZSP200L100

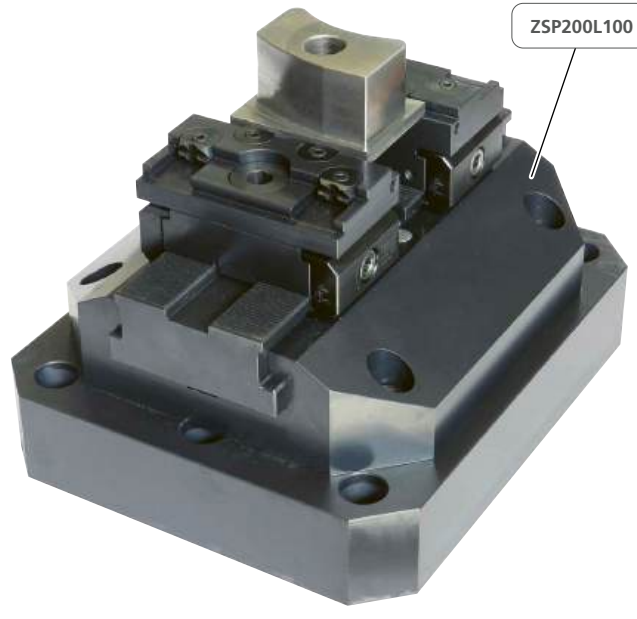

0,6 – 3,6 mm Hub

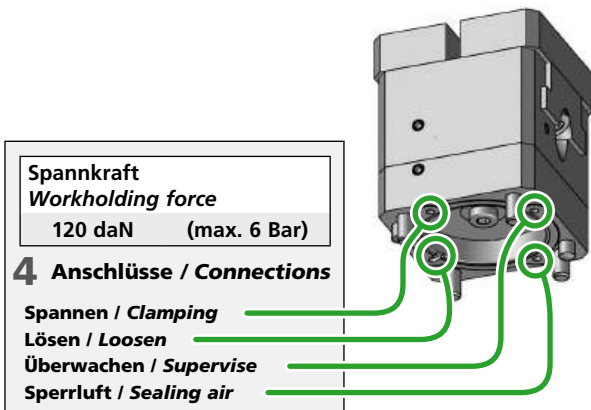
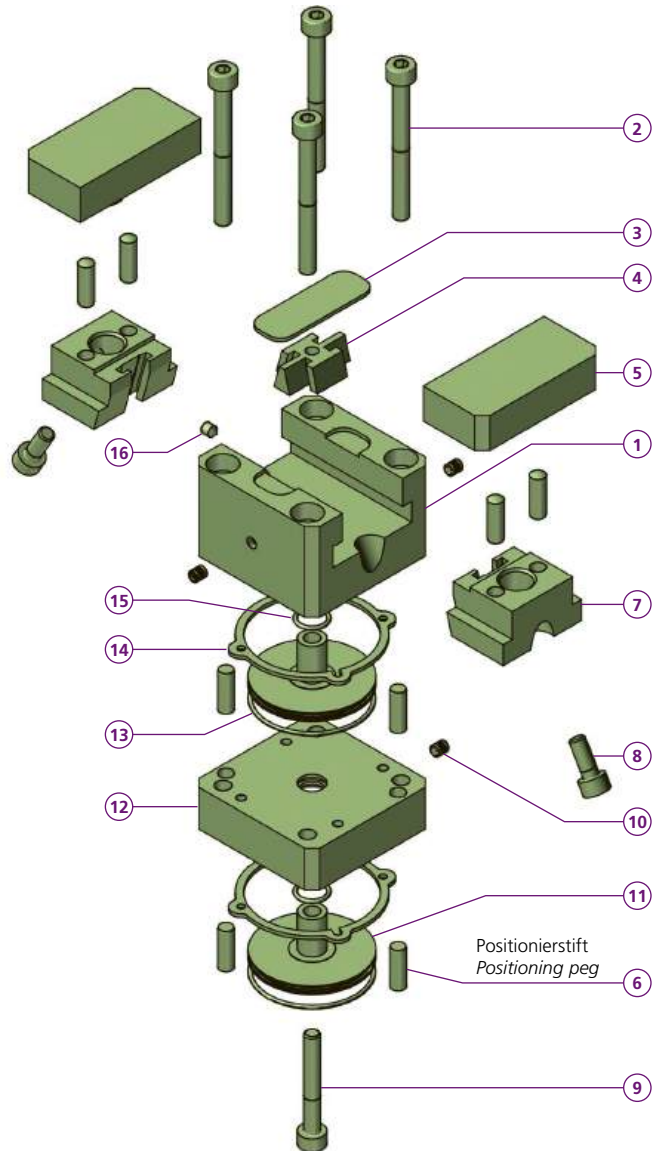
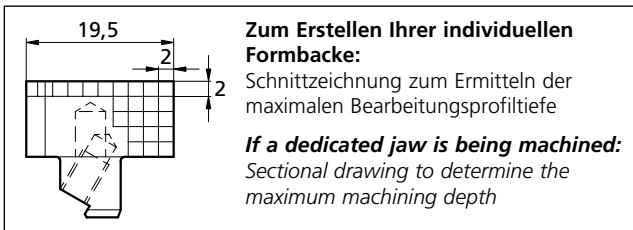
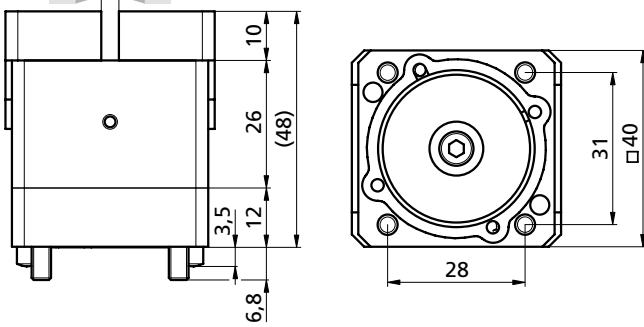

**Spannkraft**  
**Workholding force**  
120 daN (max. 6 Bar)

#### 4 Anschlüsse / Connections

**Spannen / Clamping**  
**Lösen / Loosen**  
**Überwachen / Supervise**  
**Sperrluft / Sealing air**

#### SET18ZSP40L38-2

- 1 1x TF180166
- 2 4x TN100865
- 3 1x TF180169
- 4 1x TF180168
- 5 2x B222
- 6 8x TN100428
- 7 2x TF180167
- 8 2x TN100321
- 9 1x TB180316
- 10 3x TN100824
- 11 2x TF180170
- 12 1x TF180171
- 13 2x TN100819
- 14 2x TB180306
- 15 2x TN100818
- 16 1x TN10091
- kg ~0,52

Luftvolumen / Air volume	
Spannen / Clamping	Lösen / Loosen
8,2cm <sup>3</sup>	8,4cm <sup>3</sup>

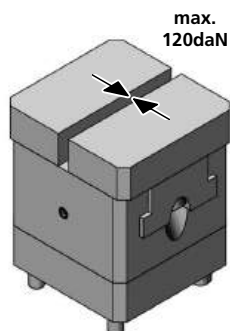

#### ZSP40L38-2

5 2x B222  
kg ~5,2

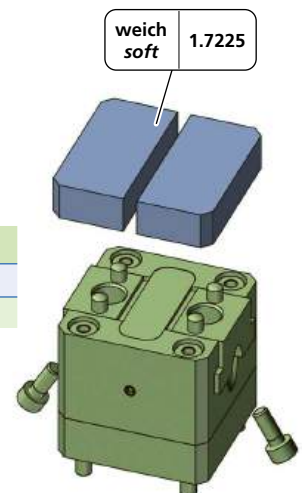

Bestellbeispiel / Ordering example: SET18ZSP40L38-2

Separat bestellen / Order separately

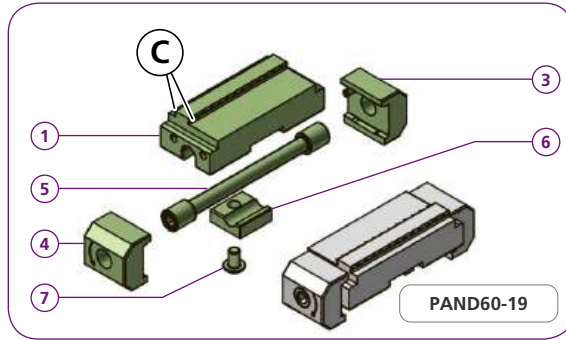
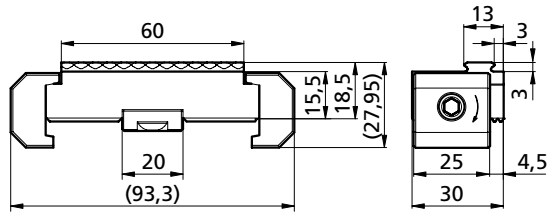
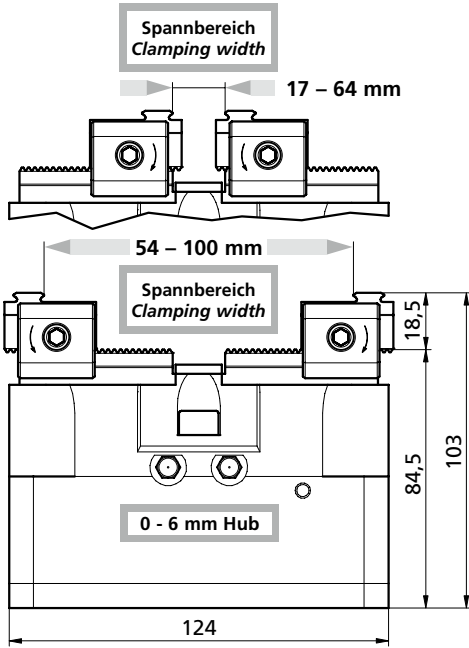

#### ZSP125L85-1

- 1 1x TB180474
  - 2 2x TB180476
  - 3 2x M8X16ISO4762
  - 4 2x M3X6DIN7991
  - 5 1x TB171140
  - 6 1x TB171141
  - 7 1x TB180477
  - 8 2x TN100014
  - 9 2x TB170530
  - 10 2x TN100021
  - 11 3x TN100009
  - 12 1x TK160467
  - 13 1x TN100012
  - 14 1x TK160075
  - 15 1x M6X35ISO4762
  - 16 1x TN100020
  - 17 1x TB180475
  - 18 2x TN100015
  - 19 4x TN100013
  - 20 1x TN100027
  - 21 1x TB180268
  - 22 4x PCPF16L6
  - 23 1x M5X6DIN913
  - 24 1x TB180478
- kg ~7,4

#### PAND60-19

- 1 1x TB171149
  - 3 1x PCSP25L
  - 4 1x PCSP25R
  - 5 1x PCS10
  - 6 1x PCGU2019
  - 7 1x M5X8ISO7380
- kg ~0,4

Luftvolumen / Air volume	
Spannen / Clamping	Lösen / Loosen
80,1 cm <sup>3</sup>	80,8 cm <sup>3</sup>



Bedienungsanleitung zu diesem pneumatischen Zentrischspanner  
Operating instructions for this pneumatic self centering vise

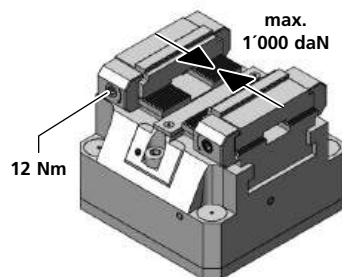

#### SET18ZSP125L85-1

- 1x ZSP125L85-1
  - 2x PAND60-19
- kg ~8,2

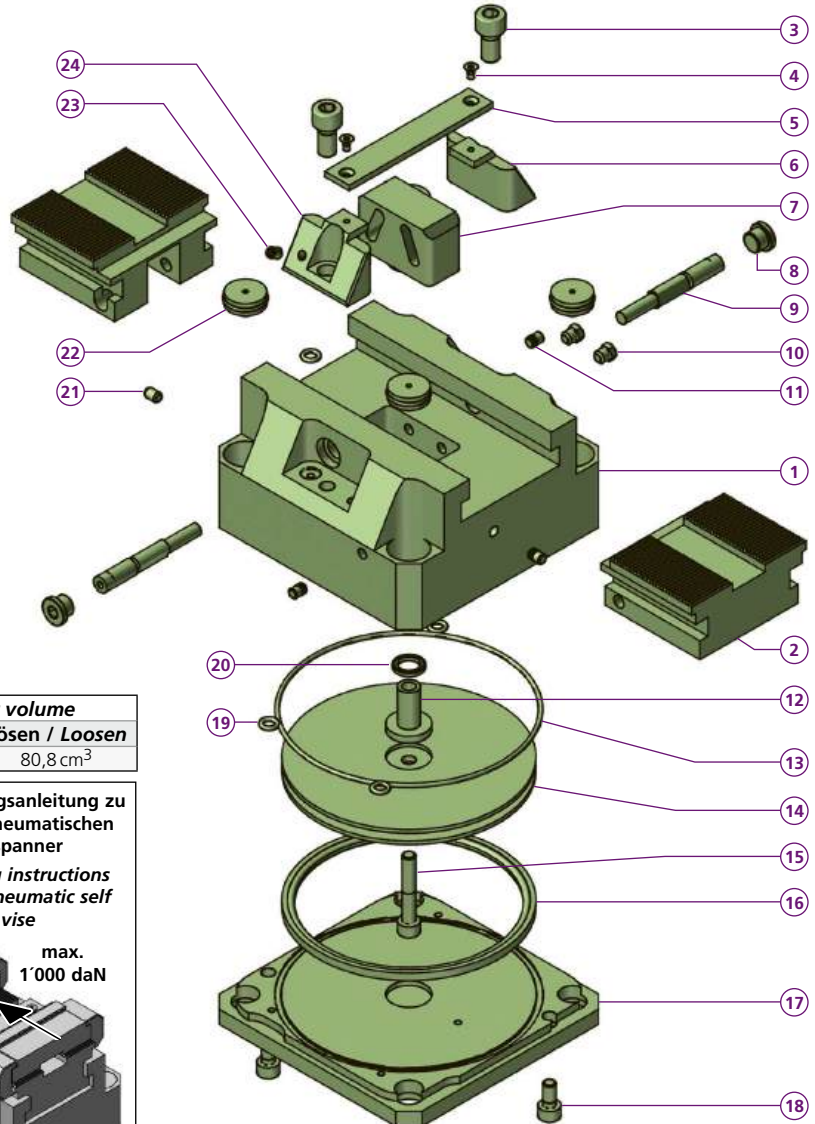

	Druck Pressure		Spannkraft Clamping force		
	Bar		~daN	~(lb)	~t
Einfacher Kolben Single piston	8	=	600	1'320	0,6
	10	=	800	1'760	0,8
	12	=	1'000	2'650	1,0

Bestellbeispiel / Ordering example: SET18ZSP125L85-1

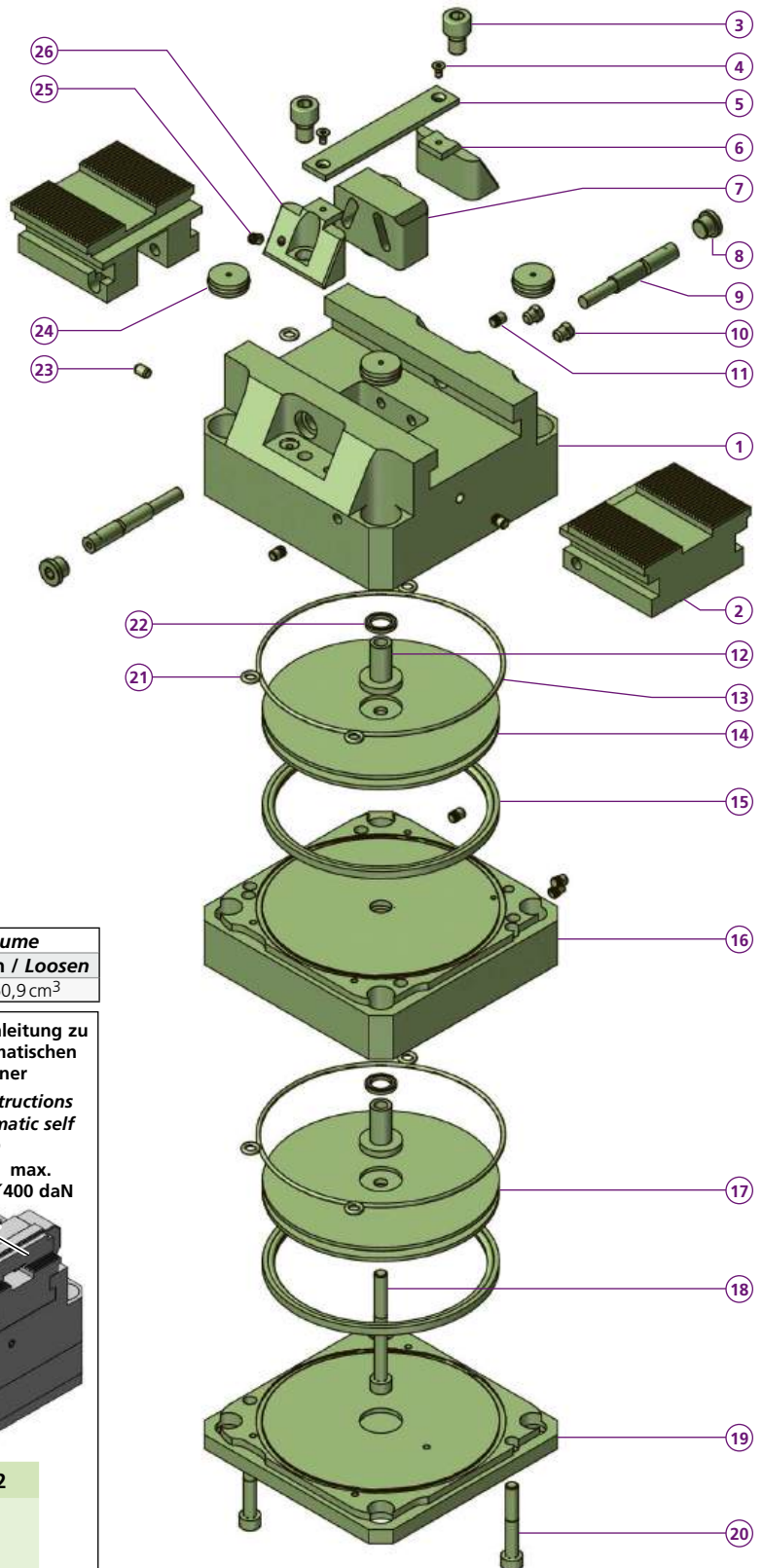
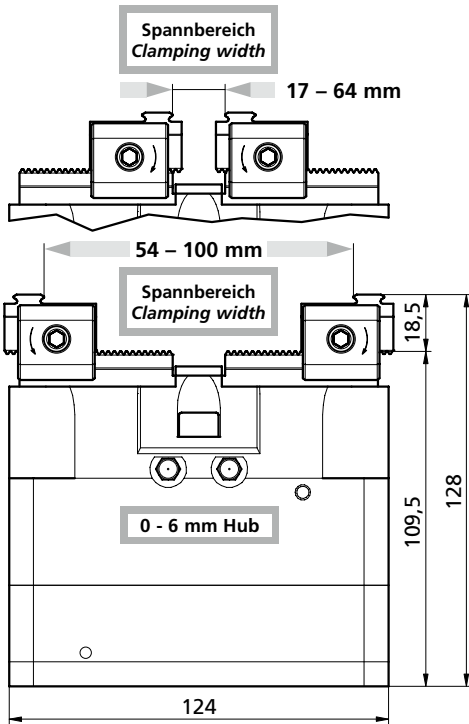

#### ZSP125L110-2

- 1 1x TB180474
  - 2 2x TB180476
  - 3 2x **M8X16ISO4762**
  - 4 2x M3X6DIN7991
  - 5 1x TB171140
  - 6 1x TB171141
  - 7 1x TB180477
  - 8 2x TN100014
  - 9 2x TB170530
  - 10 2x TN100021
  - 11 6x TN100009
  - 12 2x TK160467
  - 13 2x TN100012
  - 14 1x TB170147
  - 15 2x TN100020
  - 16 1x TB180480
  - 17 1x TK160075
  - 18 1x **M6X60ISO4762**
  - 19 1x TB180475
  - 20 2x **M6X40ISO4762**
  - 21 7x TN100013
  - 22 2x TN100027
  - 23 1x TB180268
  - 24 4x PCPF16L6
  - 25 1x M5X16DIN913
  - 26 1x TB180478
- kg ~9,4

Luftvolumen / Air volume	
Spannen / Clamping	Lösen / Loosen
160,2 cm <sup>3</sup>	160,9 cm <sup>3</sup>



Bedienungsanleitung zu diesem pneumatischen Zentrischspanner  
Operating instructions for this pneumatic self centering vise

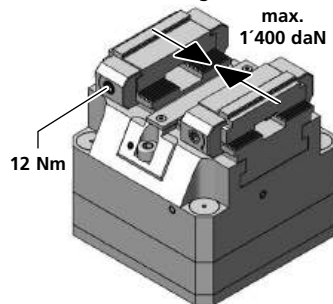

#### SET18ZSP125L110-2

- 1x ZSP125L110-2
  - 2x PAND60-19
- kg ~11,3

#### PAND60-19

- 1 1x TB171149
  - 3 1x PCSP25L
  - 4 1x PCSP25R
  - 5 1x PCS10
  - 6 1x PCGU2019
  - 7 1x **M5X8ISO7380**
- kg ~0,4

Masszeichnung & Isometrische Darstellung:

Siehe Seite | See page **p. 159**

Dimensional drawing & Isometric representation:

	Druck Pressure		Spannkraft Clamping force		
	Bar		~daN	~(lb)	~t
Doppelkolben Double piston	8	=	1'000	2'200	1,0
	10	=	1'400	3'090	1,4

Bestellbeispiel / Ordering example : SET18ZSP125L110-2

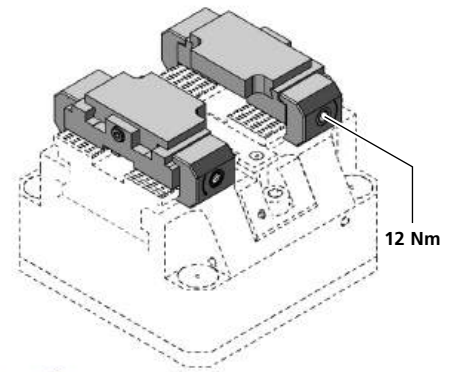
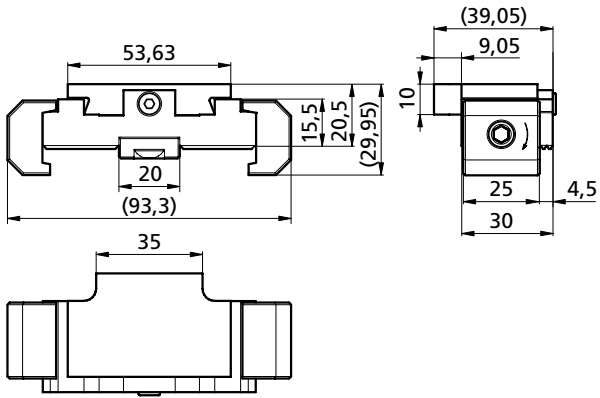

**PAND60-20.5UWB**

1	1x TK171294
2	1x TK180360
3	1x PCSP25L
4	1x PCSP25R
5	1x PCS10
6	1x PCGU2019
7	1x M5X8ISO7380
8	1x M4X8ISO4762
kg	~0,3

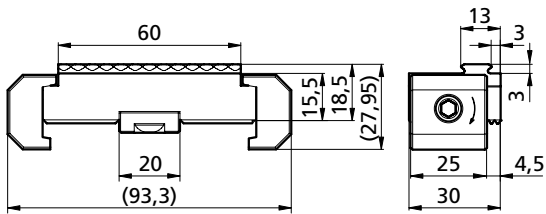
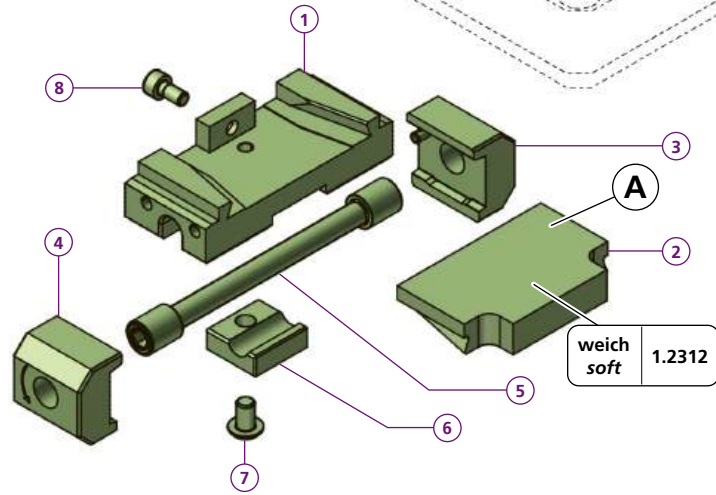

PAND60-20.5UWB

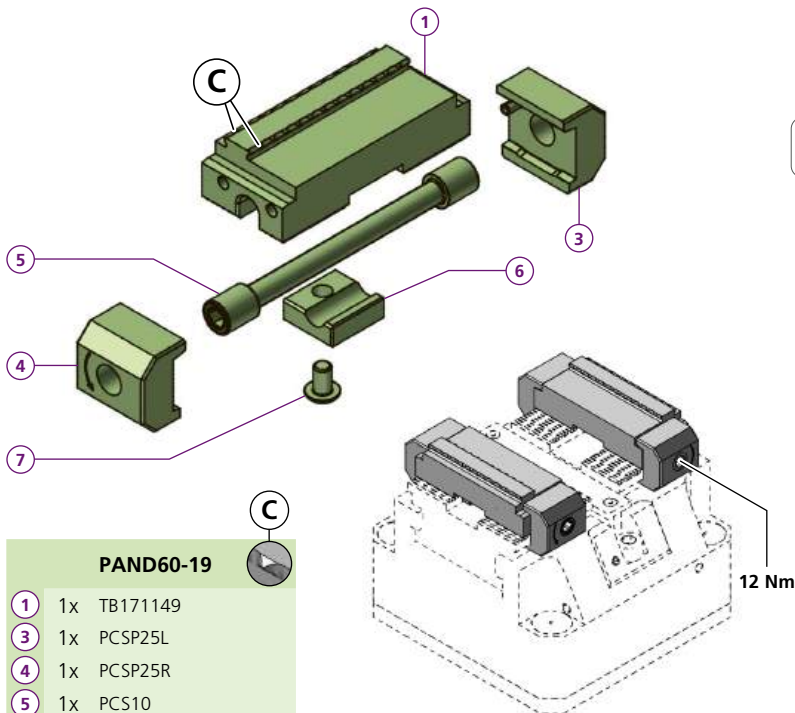

**PAND60-19**

1	1x TB171149
3	1x PCSP25L
4	1x PCSP25R
5	1x PCS10
6	1x PCGU2019
7	1x M5X8ISO7380
kg	~0,4

PAND60-19

ZSP125L85-1

Bestellbeispiel / Ordering example: PAND60-20.5UWB

# ZSP Grande

## Pneumatischer Zentrischspanner

### Pneumatic self centering vise

ZSP150L100

ZSP200L100

ZSP250L100

triCENTRO

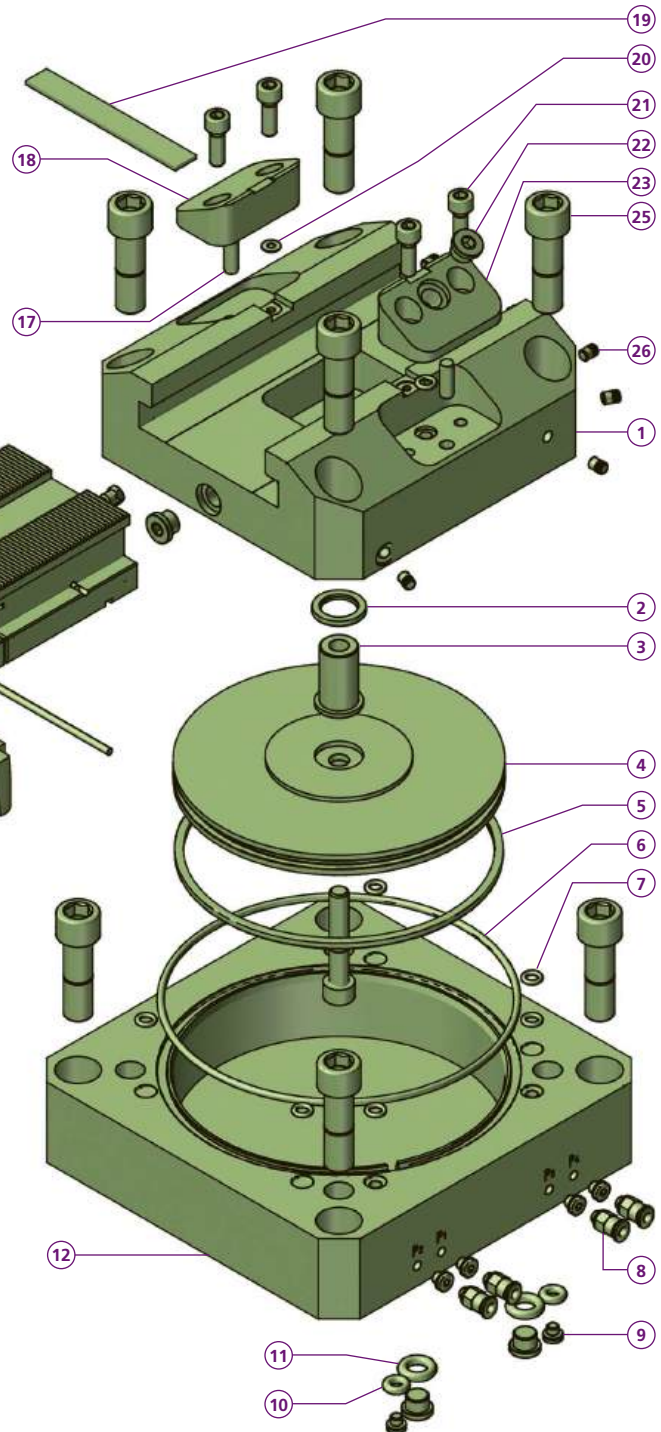
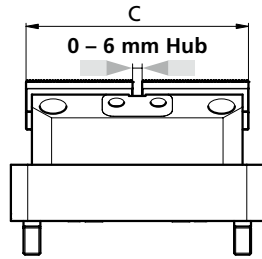
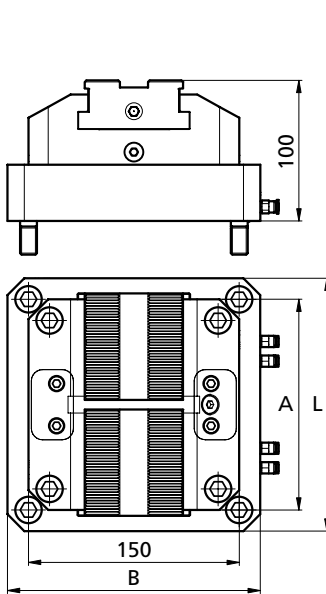



#### ZSP150L100

- 1 1x TB190122
- 2 1x TN100525
- 3 1x TB140209
- 4 1x TB190092
- 5 1x TN100595
- 6 1x TN100894
- 7 7x TN100013
- 8 4x TN100596
- 9 6x TN100914
- 10 2x TN100917
- 11 2x TN100592
- 12 1x TB190125
- 13 2x TB190087
- 14 1x TB190085
- 15 2x TN100021
- 16 2x TB190123
- 17 2x TN100453
- 18 1x TB190095
- 19 1x TB190086
- 20 2x TN100916
- 21 4x **M6X18ISO4762**
- 22 5x TN100014
- 23 1x TB190094
- 24 8x TWPAS1240
- 25 5x TN100009

A = 150  
L = 180  
B = 180  
kg ~16

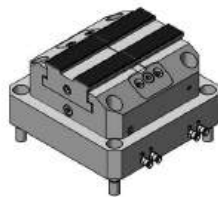
 Bedienungsanleitung zu diesem pneumatischen Zentrischspanner  
Operating instructions for this pneumatic self centering vise



 Bedienungsanleitung zu diesem pneumatischen Zentrischspanner  
Operating instructions for this pneumatic self centering vise

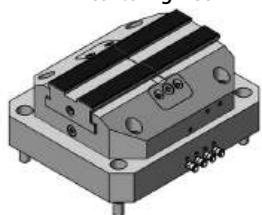

#### ZSP250L100

- 1 1x TB190083
- 12 1x TB190091
- 16 2x TF190780

A = 200  
L = 240  
B = 200  
C = 250  
kg ~25,5

 Bedienungsanleitung zu diesem pneumatischen Zentrischspanner  
Operating instructions for this pneumatic self centering vise

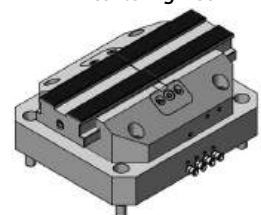

Spannkraft siehe Seite  
Clamping force see page

161

Bestellbeispiel / Ordering example: ZSP150L100

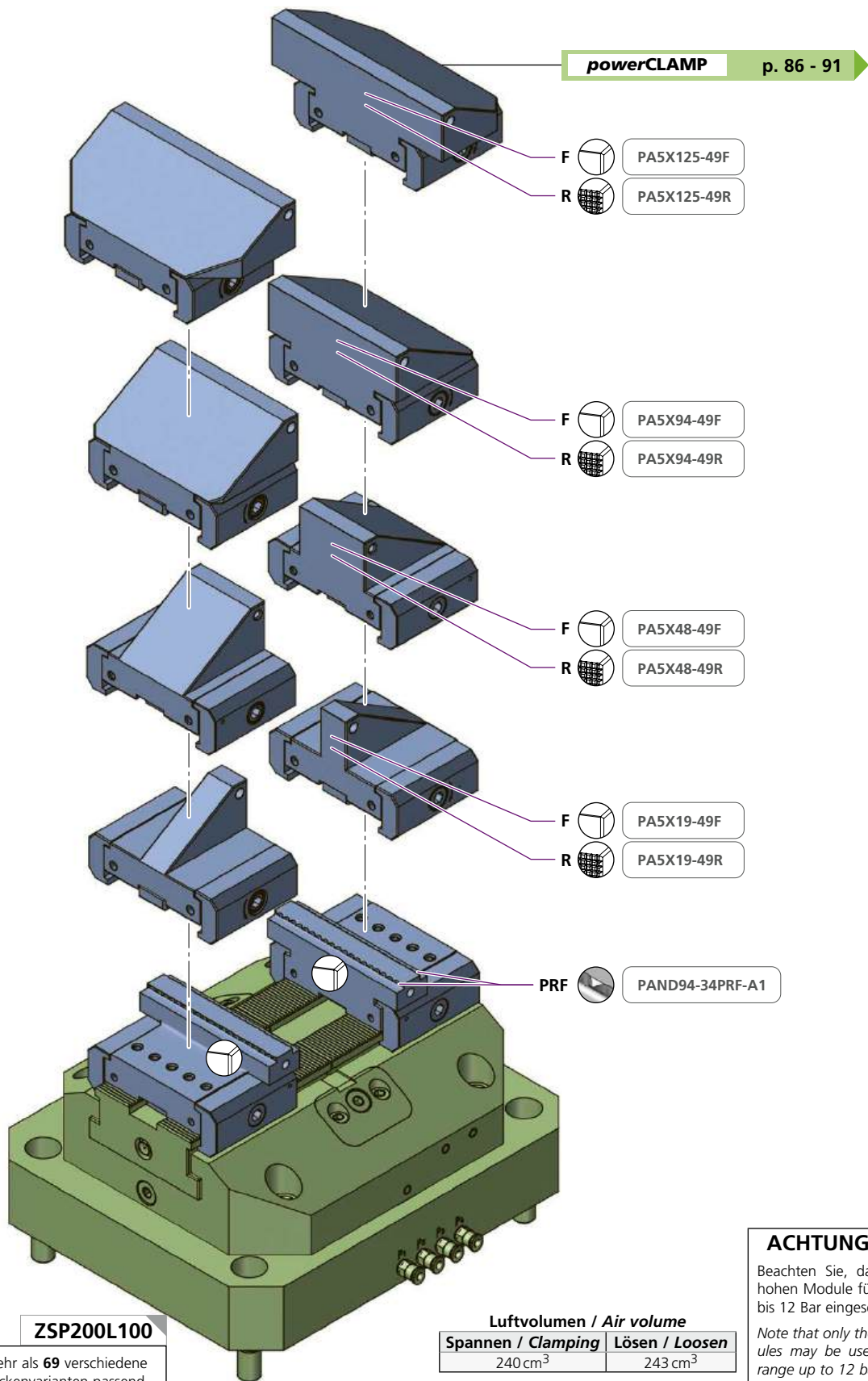

**ZSP200L100**

Mehr als **69** verschiedene Backenvarianten passend zu dieser Schnellwechelschnittstelle.

More than **69** different jaw modules to match this rapidly changing interface.

**Luftvolumen / Air volume**

<b>Spannen / Clamping</b>	<b>Lösen / Loosen</b>
240 cm <sup>3</sup>	243 cm <sup>3</sup>

Druck / Pressure	Spannkraft / Clamping force			
	Bar	~daN	~(lb)	~t
Druckübersetzer Pressure intensifier 1:2	5	= 1'100	2'420	1,1
	8	= 1'500	3'300	1,5
	10	= 2'000	4'400	2,0
	12	= 2'400	5'290	2,4

**ACHTUNG / CAUTION**

Beachten Sie, dass nur die 34 mm hohen Module für den Druckbereich bis 12 Bar eingesetzt werden dürfen.

Note that only the 34 mm high modules may be used for the pressure range up to 12 bar.

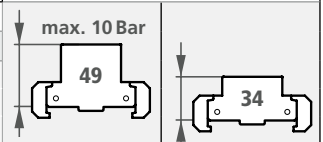

Bestellbeispiel / Ordering example: 1 x ZSP200L100 & 2 x PA5X48-49F

Separat bestellen / Order separately

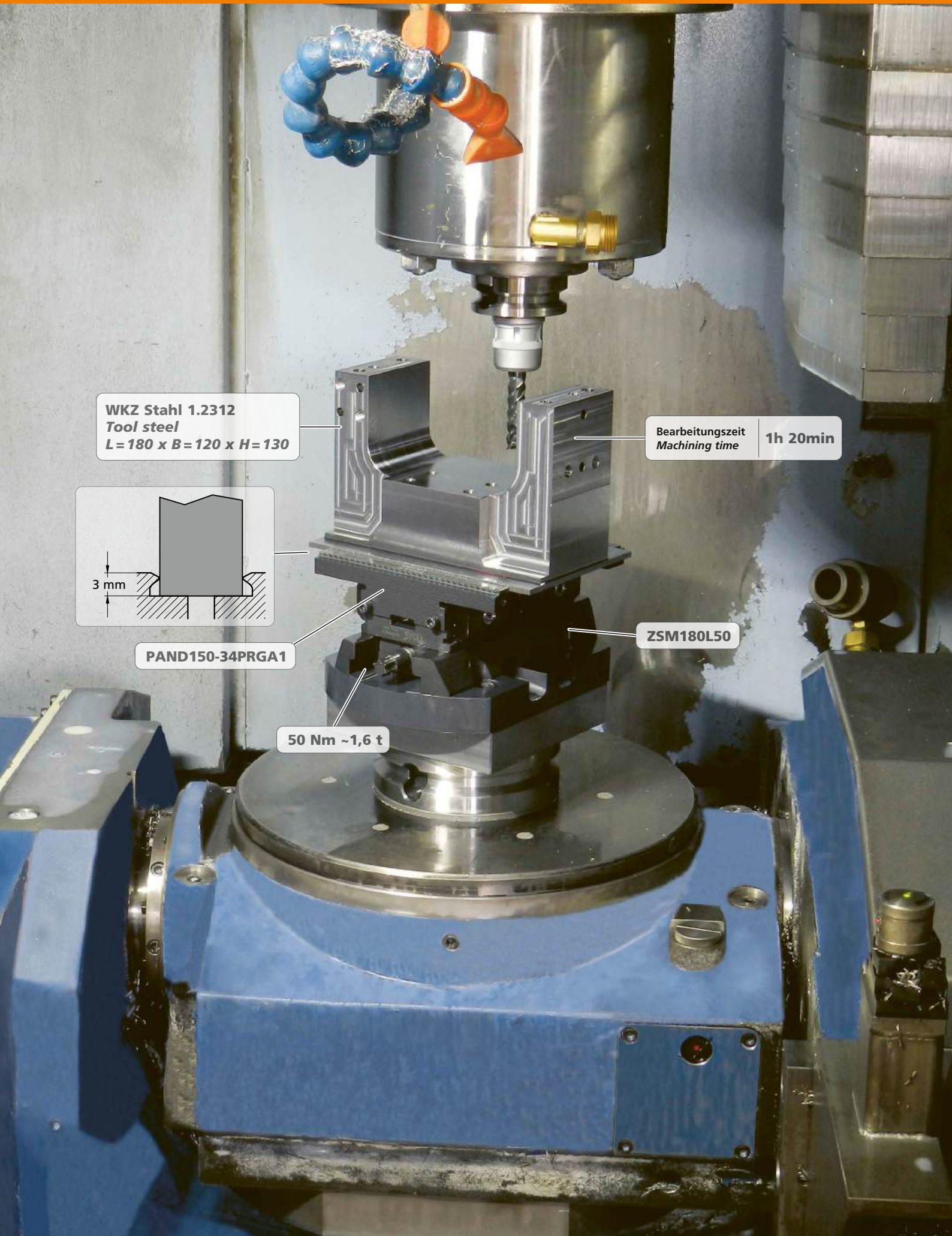

WKZ Stahl 1.2312  
Tool steel  
L = 180 x B = 120 x H = 130

Bearbeitungszeit  
Machining time 1h 20min

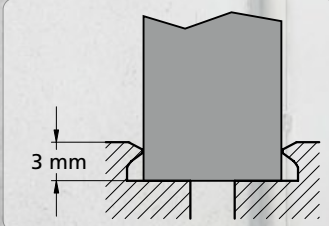

PAND150-34PRGA1

ZSM180L50

50 Nm ~1,6 t



**micro**CLAMP



# compactCLAMP

Mehrfachspannsystem / Multiple workholding system

**Nur noch Ersatzteile und  
Nachlieferungen!  
Keine Compact Clamp  
Neuentwicklungen mehr!**

Beim Compact Clamp lassen sich die Spannmodule auf einer Basisschiene mittels Passstiften massgenau positionieren. Die Schienen sind mit einem Lochraster mit 7,5 mm Teilung, die Spannmodule mit einer 10 mm-Teilung versehen. Dank Anwendung des Nonius-Prinzips entsteht ein kleinstmöglicher Positionierschritt von 2,5 mm. Bei einem Backenhub von 4 mm ist es somit möglich, an jedem beliebigen Punkt der Schiene nullpunktbezogen zu spannen. Ab 20 mm ist die Bearbeitung von drei Seiten möglich. Da das Spannmodul mit vier Schrauben in den T-Nuten verankert wird, ist es sinngemäss auch möglich, an Stelle der Original-Spannmodule individuelle Vorrichtungen und Sonderbacken zu befestigen. Das Compact Clamp Spannsystem ist ein System für Tüftler. Praktisch keine Spannprobleme bleiben damit ungelöst. Dafür sind die Umrüstzeiten etwas länger als beim Power Clamp. Compact Clamp-Basisschienen sind in den Längen 113 - 750 mm lieferbar. Die angebotenen Befestigungsrastrer sind 40 und 50 mm. Neben den Stahlschienen werden für leichte Arbeiten auch Schienen aus Aluminium hergestellt.

**Only spare parts and  
additional deliveries! No  
more new Compact Clamp  
developments!**

*In the Compact Clamp, the vise modules are positioned precisely on a base rail by means of alignment pins. On the base rail, positioning holes are located on a 7,5 mm grid, while on the vise module there is one with a 10 mm spacing. Following the vernier principle, the smallest possible positioning step is therefore 2,5 mm. With a jaw movement of 4 mm it is therefore possible to clamp the workpiece in any desired position with a known distance to program Zero (original datum face). From 20 mm up, three sided machining is possible. Special jaws or dedicated fixtures may easily be bolted onto the rails in place of standard vise modules if the need arises. They may be anchored in the T-slots and located by using alignment pins in the positioning holes. Hence the Compact Clamp is the ideal workholding system for "do it yourself" customers. Change over times are longer than with the Power Clamp, though. Available Compact Clamp base rails lengths: 113 - 750 mm. The fastening grids on the rails are 40 and 50 mm. In addition those made of steel we also produce rails made of aluminum for light work.*



Sie können den  
Katalog unter der  
folgenden Link herunter-  
terladen!

You can download the  
catalogue at the fol-  
lowing download  
link!



Einleitung | *Introduction* ..... 166 - 167

Anwendungsbeispiele | *Examples of application* ..... 168 - 171



Spannkraft und Drehmoment | *Workholding force and torque* ..... 173

Vorrichtungsbau - Präge- und Anschlagmodule (Linear)  
*For dedicated fixture - stamping- and end modules (linear)* ..... 174 - 176

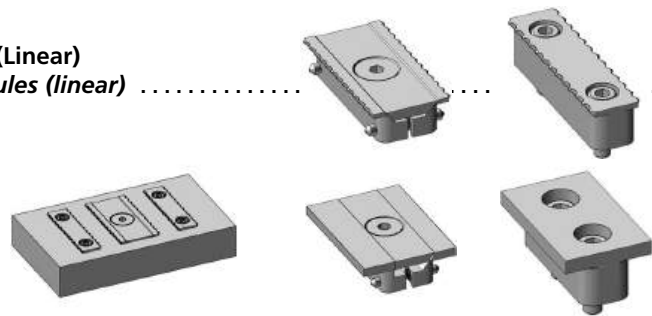

Niederzugspannmodule | *Pull down clamp modules* ..... 177 - 195

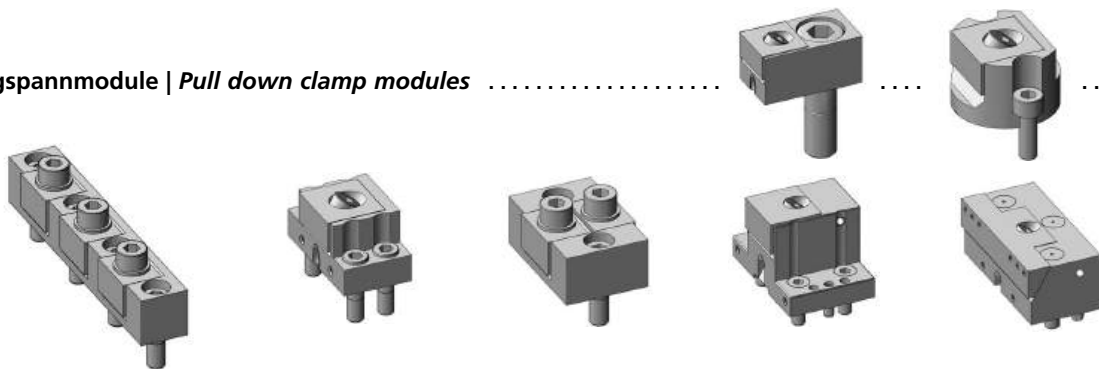

Linearspannmodule | *Linear clamping modules* ..... 196 - 203

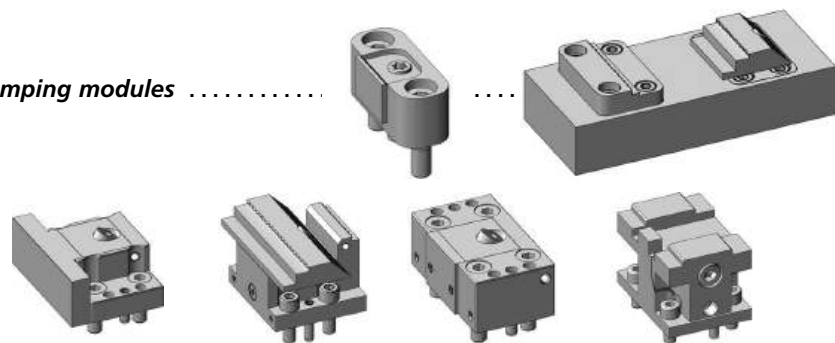

Zubehör | *Accessories* ..... 204 - 205



Zum Aufbau kundenspezifischer Sondervorrichtungen für höchste Werkstückdichte im Arbeitsraum von Bearbeitungszentren ist das Spannsystem Micro Clamp ausgelegt (Spezielle Anschlagbacken, siehe Bild). Sehr kompakte Spannmodule mit Prägebacken verwirklichen eine zuverlässige Aufspannung bei nur etwa 2 mm Verlust an Rohmaterial

*Clamps for dedicated fixtures for high density to get your best output from your machine. Clamping modules in different sizes and shapes and jaws with serrations also flat and carbide coated are available.*

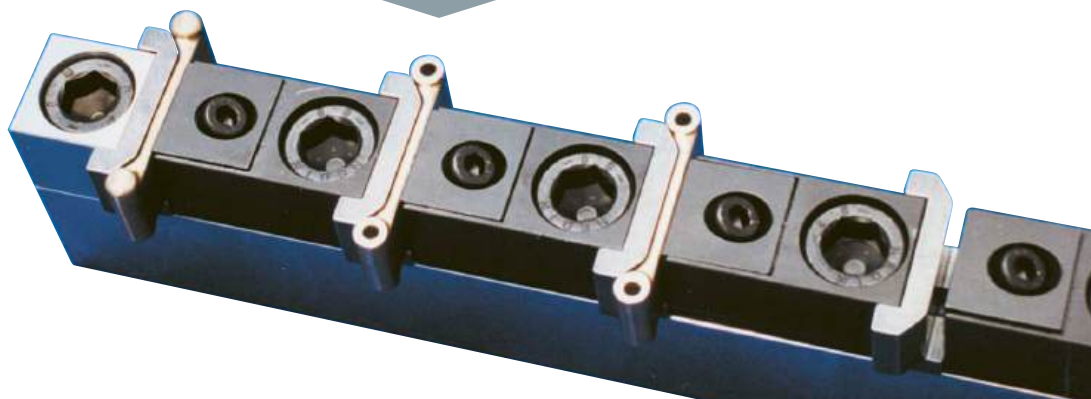

**Kleinst-Spannmodule für den Vorrichtungsbau. *Extremely small clamping modules for dedicated fixtures.***

**Hohe Spanndichte**

Die Spannmodule haben auf der Vorderseite eine Spannbacke, die Rückseite ist zu den Befestigungsbohrungen massgenau geschliffen oder gefräst. Damit kann diese Anschlagfläche für das folgende Werkstück genutzt werden. Diese Anordnung lässt eine sehr hohe Spanndichte zu. Beim kleinsten Micro Clamp-Modul sind nur 15 mm Spannabstand erforderlich.

***High workholding density***

*These clamping modules have a clamping jaw on the front, while rear is precisely ground or milled with reference to the fixing holes. This means that it can be used as a datum face for the following workpiece. This arrangement allows very high clamping densities. Only 15 mm clamping clearance is needed between workpieces using the smallest Micro Clamp module.*

- Maximale Spannkraft der Module 2,8t (28'000N)
- Benötigter Platz zwischen den Werkstücken ab 15 mm
- Spannhub ab 1,5 mm
- Genaue Positionierung durch Passschrauben und Positionierstifte

- *Clamping force up to 2,8t (28'000N)*
- *Space between workpieces only 15 mm*
- *Stroke of jaw from 1,5 mm*
- *Precise positioning by ground shoulder screws or dowel pins*



Ein grosses Angebot an verschiedensten Spannmodulen.  
*A wide range of clamp modules in different sizes are available*

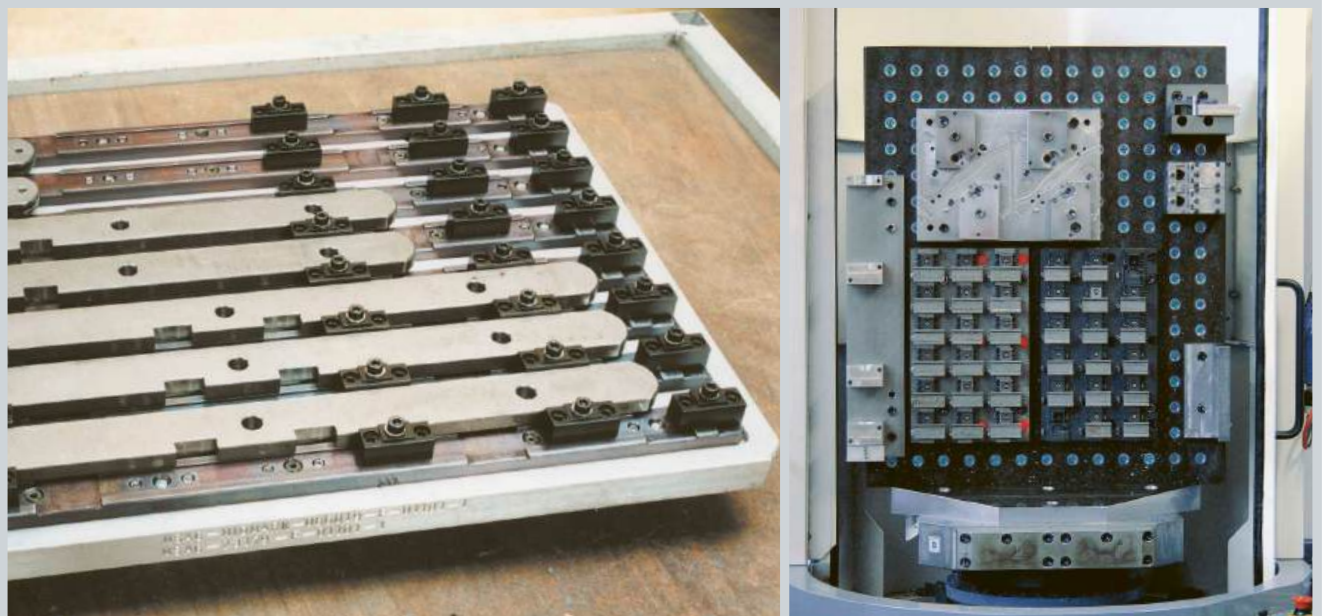

Hohe Spanndichte für Werkstücke in grossen Stückzahlen.  
*High density fixture plates for repeating orders in high quantities*

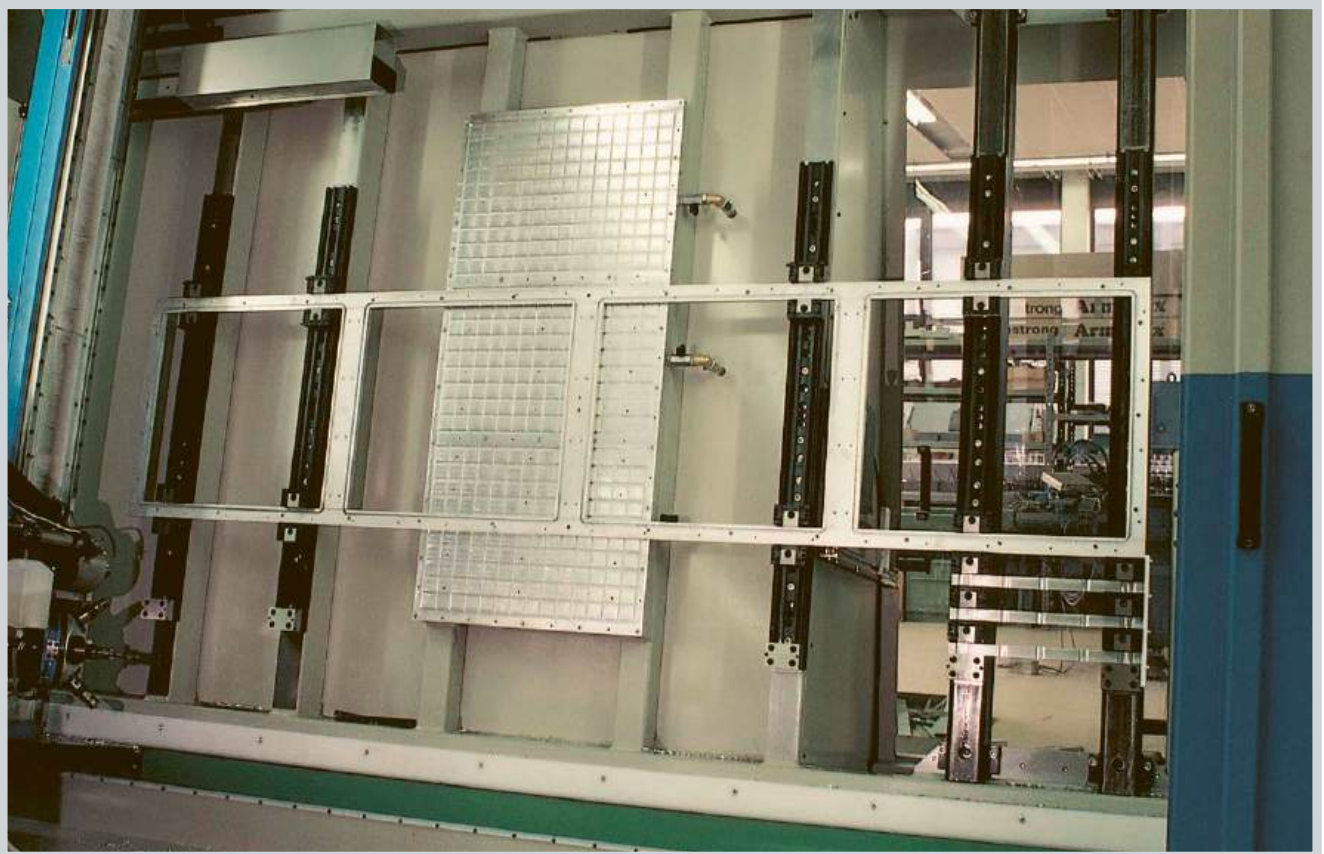

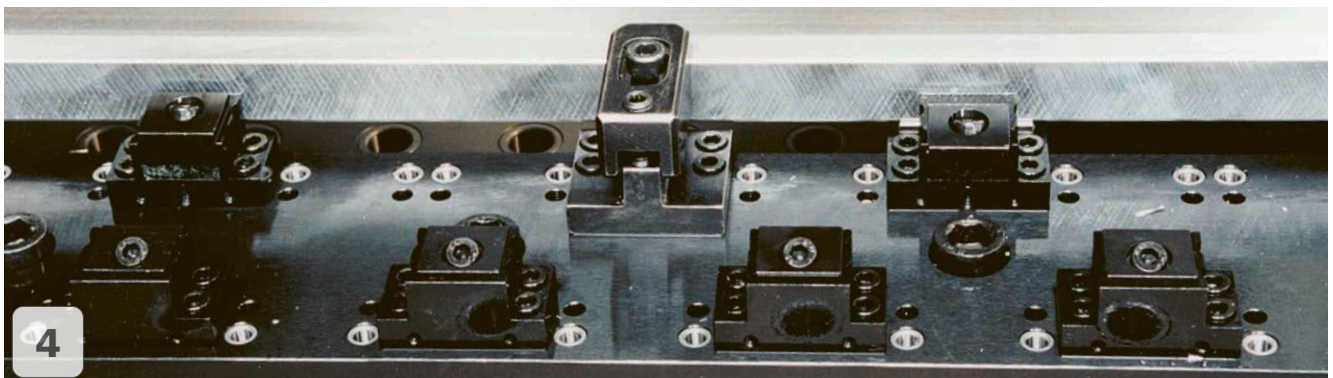
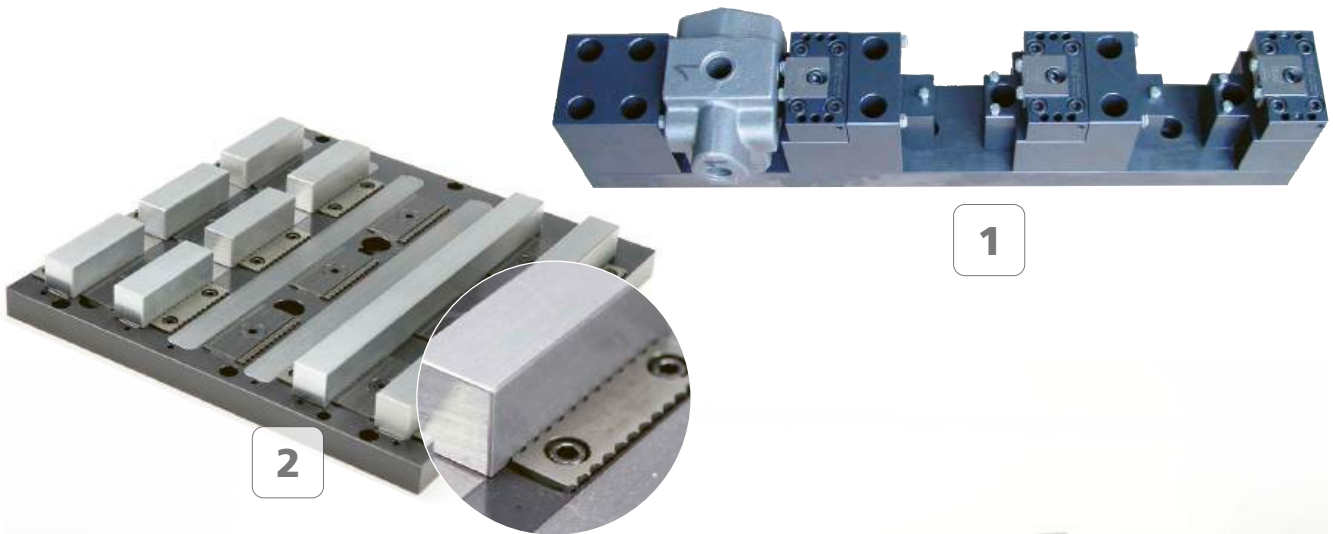

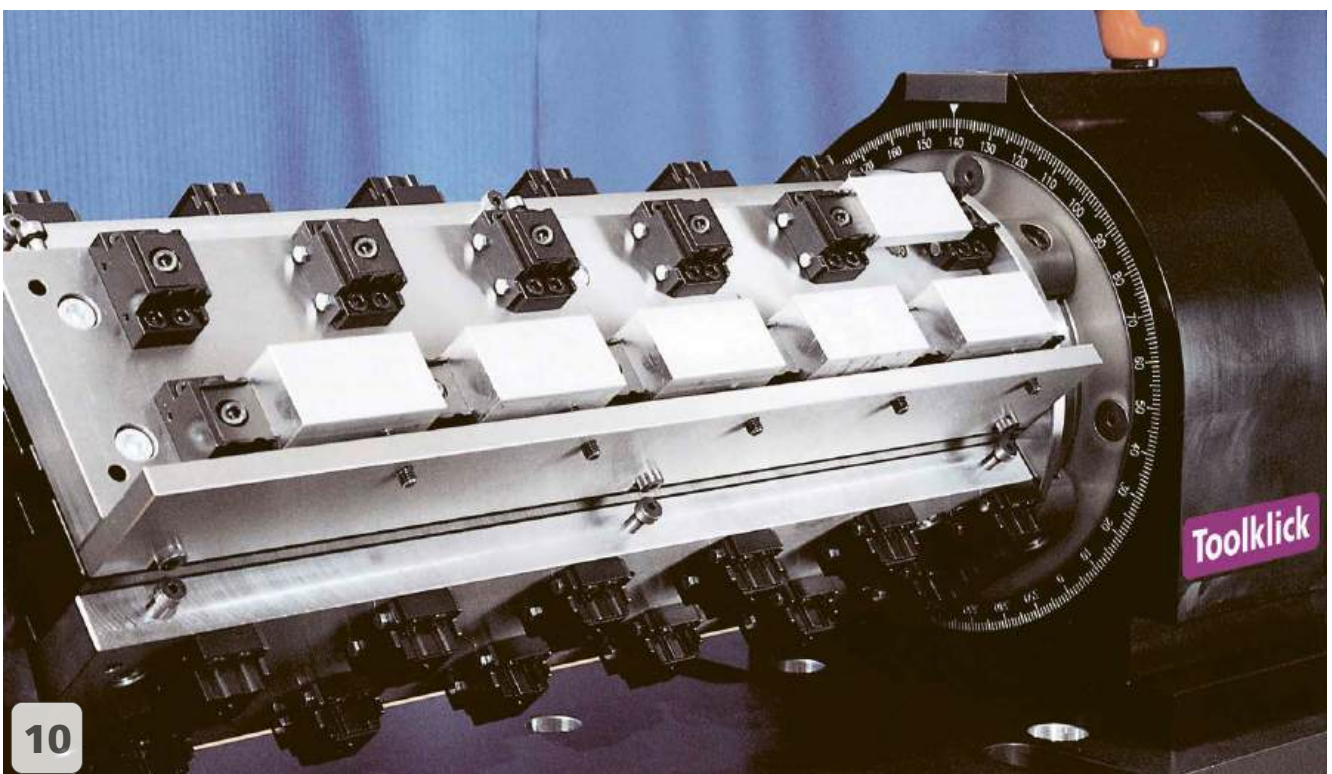
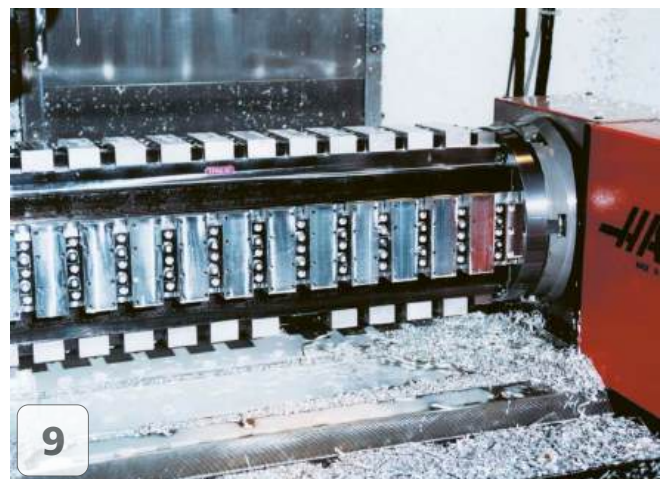



**11** 84 Teile sind gespannt mit Micro Clamp und werden jeweils nachts unbemannt produziert  
*84 parts are clamped with Micro Clamp and are machined always at right unmanned*



**12**

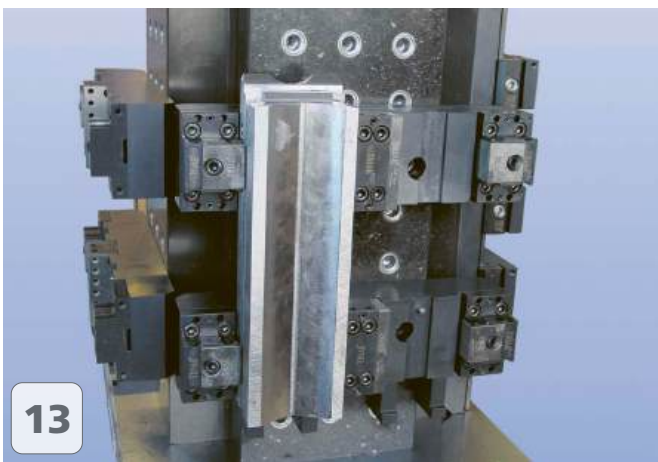

**13**



**16**

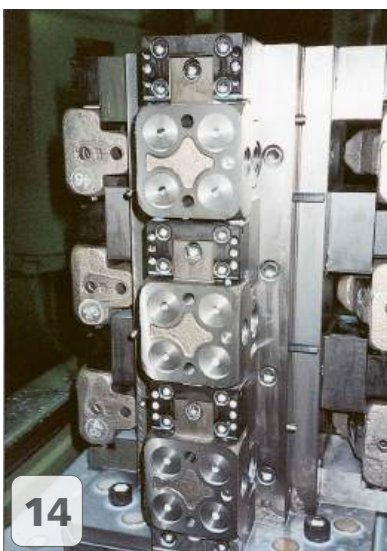

**14**



**15**

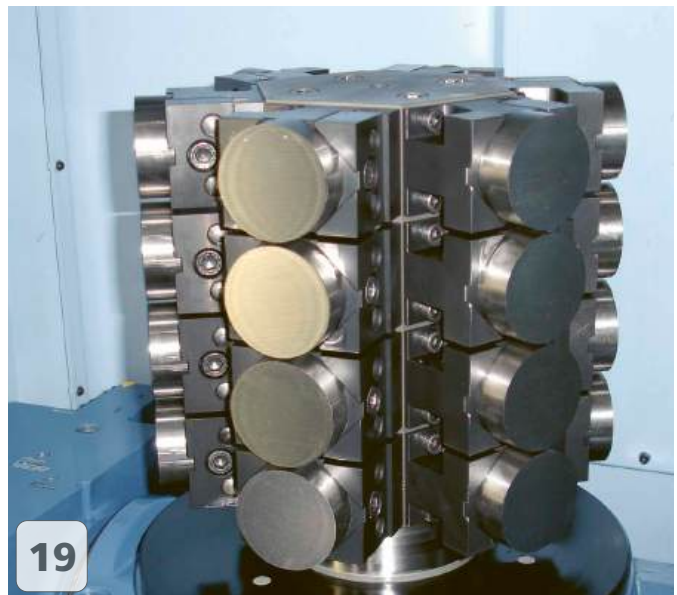
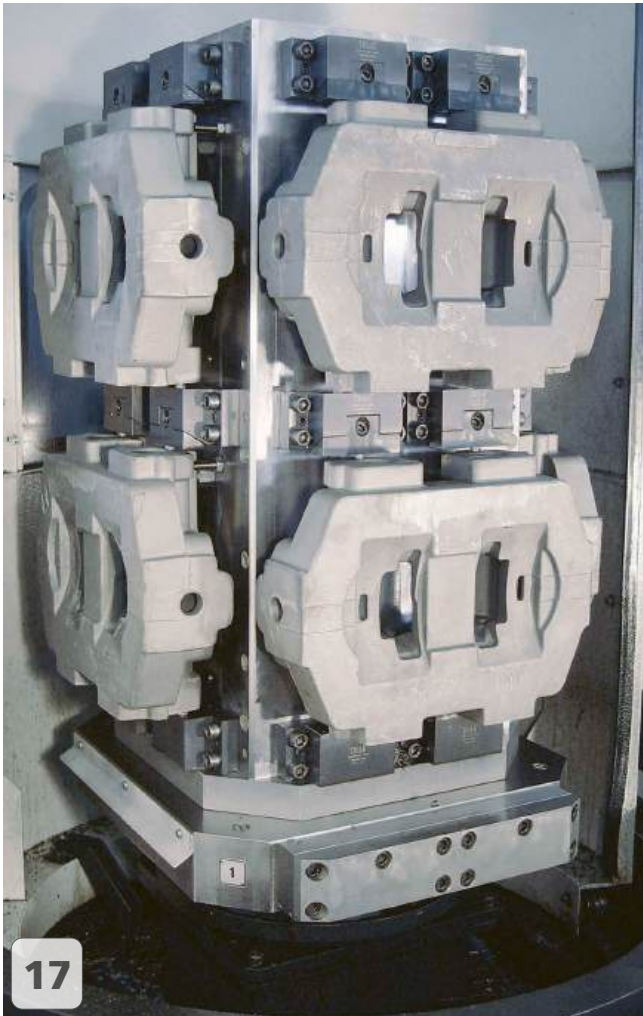

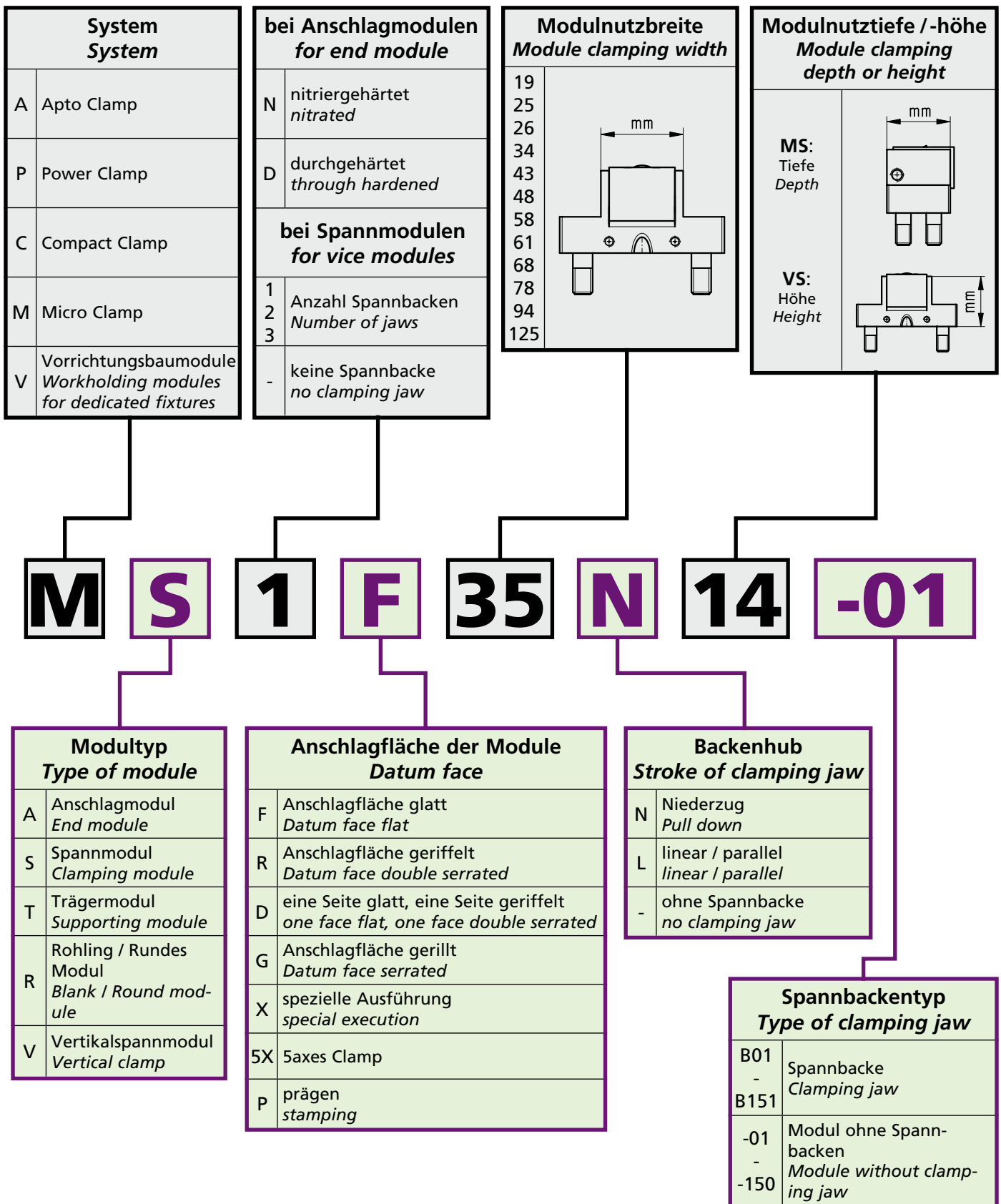

# ACHTUNG / CAUTION

**WICHTIG:** Die im Micro Clamp Kapitel angegebenen Drehmomente sind die absoluten Maximalwerte. Über die Spannkraften gibt die untenstehende Tabelle Auskunft.

**IMPORTANT:** The torque numbers specified in the Micro Clamp chapter represent the absolute maximum. The table at the bottom of this page provides further information on the workholding forces.

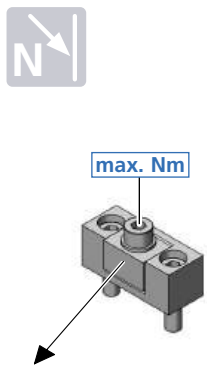
Niederzug-Spannmodule Pull down module	MC-Module	Schraube Screw	Drehmoment Torque		Spannkraft Workholding force		
			Nm	(lb-ft)	~daN	~(lb)	~t
	MR1F 30N23 -07	M5	10	7,4 =	1020	2250	1,02
	MS1F 22N40 -07		10	7,4 =	1020	2250	1,02
	MS1F 24N22 -07		10	7,4 =	1020	2250	1,02
	MS1R/F 25N25 -13	M6	15	11 =	1520	3350	1,52
	MS1F 35N14 -01	M5	10	7,4 =	1020	2250	1,02
	MS1F 35N22 -01		10	7,4 =	1020	2250	1,02
	MS2X 35N23 -01		10	7,4 =	1020	2250	1,02
	MS2F 60N14 -01		10	7,4 =	1020	2250	1,02
	MS3F 85N14 -01		10	7,4 =	1020	2250	1,02
	VS1R 19N35 -20		M6	15	11 =	1520	3350
	VS1R 26N35 -26	M8	25	18,4 =	2100	4630	2,10
	VS1R 38N50 -60		25	18,4 =	2100	4630	2,10
	VS1R/F 41N30 -60		25	18,4 =	2100	4630	2,10
	VS1R/F 80N30 -36		25	18,4 =	2100	4630	2,10
	VS1R 80N50 -36		25	18,4 =	2100	4630	2,10
	VS1R/F 80N30 -60		25	18,4 =	2100	4630	2,10
	VS1R 80N50 -60	M10	25	18,4 =	2100	4630	2,10
	VS1R/F 125N49 -95		40	29,5 =	2800	6170	2,80
VS2R 80N30 -60	25		18,4 =	2100	4630	2,10	
VS2F 90N30 -60	25		18,4 =	2100	4630	2,10	
Linear-Spannmodule Linear module	MS1F (MS1R) 35L14 -152	M6x0,5	10	7,4 =	570	1260	0,57
	MS2P (MS1P) 58L14 PRG15	M8	15	11 =	600	1320	0,6
	MS2F (MS1F) 58L14 W251		15	11 =	600	1320	0,6
	VS1R 26L35 -31		25	18,4 =	2100	4630	2,10
	VS1R/F 41L30 -51		25	18,4 =	2100	4630	2,10
	VS1R/F 80L30 -51		25	18,4 =	2100	4630	2,10
	VS1X 68L20 -105		40	29,6 =	1600	3530	1,60
	VS1X 59L60 K	M10	50	37 =	1880	4140	1,88
	VS1X 59L60 H5		50	37 =	1640	3620	1,64



Schraube Screw	Drehmoment Torque		Spannkraft Workholding force		
M5 + M6	4	3 =	500	1100	0,50
	5	3,7 =	580	1280	0,58
	6	4,4 =	690	1520	0,69
	7	5,2 =	780	1720	0,78
	8	5,9 =	880	1940	0,88
	9	6,6 =	980	2160	0,98
	10	7,4 =	1020	2250	1,02
M6	12	8,9 =	1220	2690	1,22
	14	10,4 =	1450	3200	1,45
	15	11 =	1520	3350	1,52
M8	4	3 =	410	900	0,41
	5	3,7 =	490	1080	0,49
	6	4,4 =	560	1250	0,56
	7	5,2 =	660	1460	0,66
	8	5,9 =	730	1610	0,73
	9	6,6 =	810	1790	0,81
	10	7,4 =	900	1980	0,90
	15	11 =	1520	3350	1,52
M10	20	14,8 =	1810	3990	1,81
	25	18,4 =	2100	4630	2,10
	10	7,4 =	400	880	0,40
	20	14,8 =	1400	3090	1,40
	30	22,1 =	2000	4410	2,00
40	29,5 =	2800	6170	2,80	

Keilspanner in weicher Ausführung zum Bearbeiten von Formbacken.

Double angle clamps with soft jaws for making shaped forms.

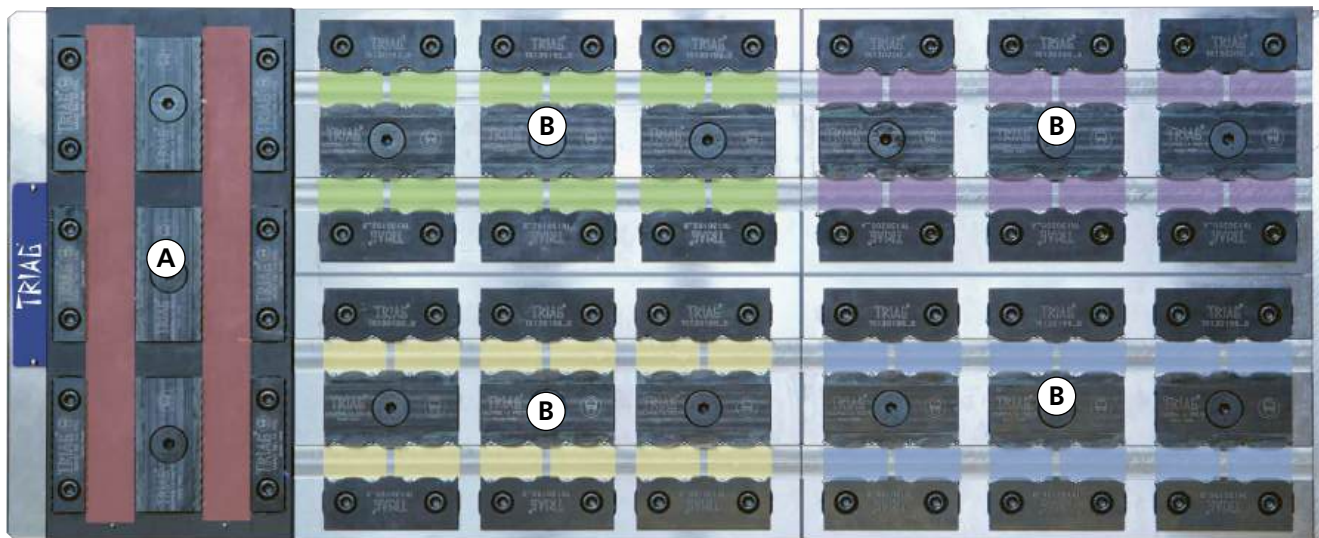

**A** Prägebacken Spanntiefe 1,8 mm  
 12 Werkstücke werden hergestellt  
*First clamp 12 parts with stamping jaws  
 clamping depth 1,8 mm*

**B** 4 x 12 verschiedene Teile werden in der  
 2. Spannung bearbeitet  
*4 times 12 different parts are machined  
 in the second operation*

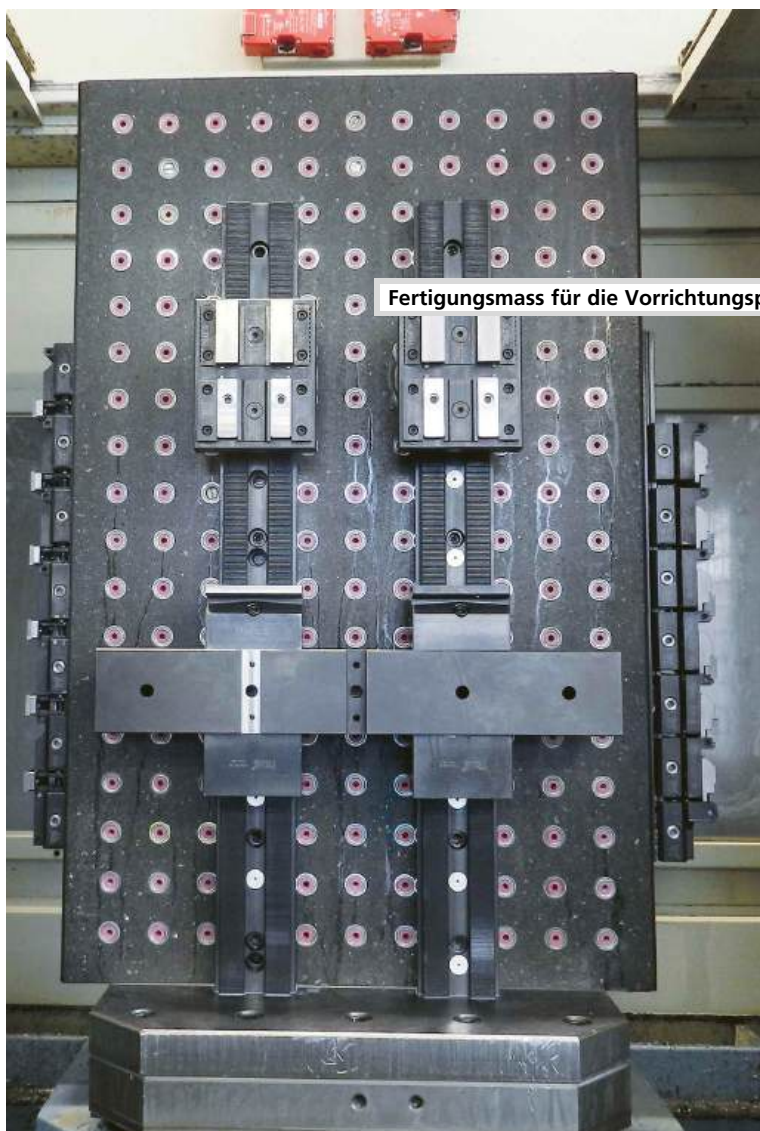

Fertigungsmass für die Vorrichtungsplatte: / Machining data for the fixture plate: p. 175

**Fräser / Milling cutter**

Der abgebildete Fräser benötigt man für die Herstellung der «Kerben».  
 Siehe Fertigungsmasse für die Vorrichtungsplatte Seite 175.

*The illustrated milling cutter is required for the production of "notches".  
 Manufacturing drawing for the fixture plate on page 175.*

45°	d	D	L1	H	z	L
TK150057	6	6,0	24,0	1,5	3	58

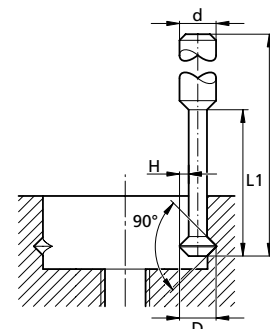

Fertigungsmasse für die Vorrichtungplatte / Machining data for the fixture plate

<p><b>Mass</b>  <b>X (X1) = B + 24 mm</b>  <b>Beispiel:</b>          Bauteilbreite = 14 mm</p> <p>Taschenabstand          X = 14 + 24 = 38          Das ergibt eine Einlegeluft von 0,8 mm          (Hub bis 2,7 mm)</p>	<p><b>Dimension</b>  <b>X (X1) = B + 24 mm</b>  <b>Example:</b>          Width of component part = 14 mm</p> <p>Distance of pocket          X = 14 + 24 = 38          This makes a play of 0,8 mm          (stroke till 2,7 mm)</p>	<p><b>Mass</b>  <b>X2 = B + 33,5 mm</b>  <b>Beispiel:</b>          Bauteilbreite = 14 mm</p> <p>Taschenabstand          X = 14 + 33,5 = 47,5          Das ergibt eine Einlegeluft von 0,8 mm          (Hub bis 2,7 mm)</p>	<p><b>Dimension</b>  <b>X2 = B + 33,5 mm</b>  <b>Example:</b>          Width of component part = 14 mm</p> <p>Distance of pocket          X = 14 + 33,5 = 47,5          This makes a play of 0,8 mm (stroke          till 2,7 mm)</p>

Hub bis / Stroke till = 2,7 mm

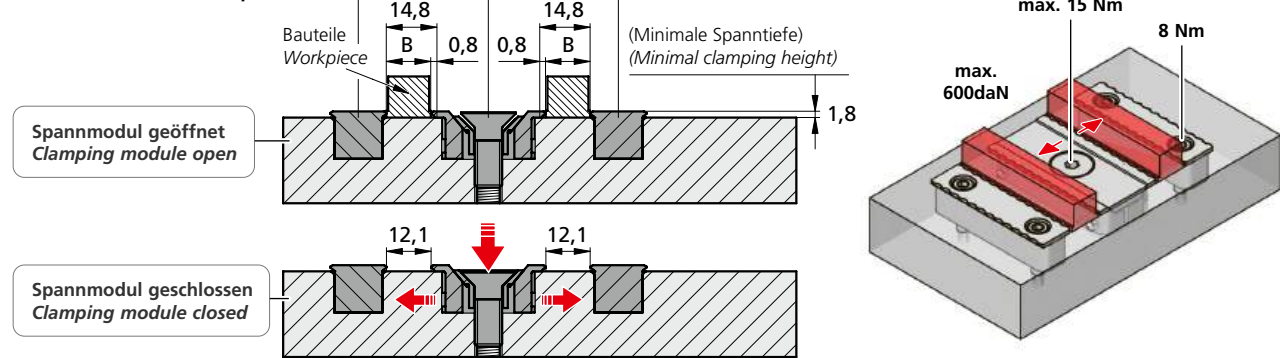

<p><b>MS2P58L14PRG15</b></p> <ul style="list-style-type: none"> <li>1 2x TK120225</li> <li>2 1x TK120227</li> <li>3 1x M8X22DIN7991</li> </ul> <p>Y 4,7 mm i 57HRC kg ~0,12</p>	<p><b>MS1P58L14PRG15</b></p> <ul style="list-style-type: none"> <li>1 1x TK120225</li> <li>2 1x TK120721</li> <li>3 1x M8X22DIN7991</li> <li>4 1x TK120720</li> </ul> <p>Y 4,7 mm i 57HRC kg ~0,12</p>	<p><b>MAND58-14PRG</b></p> <ul style="list-style-type: none"> <li>1 1x TK120226</li> <li>3 2x M5X16ISO4762</li> </ul> <p>Y 4,7 mm i 57HRC kg ~0,08</p>	<p><b>MAND58-14PRG6</b></p> <ul style="list-style-type: none"> <li>1 1x TB150282</li> <li>3 2x M5X16ISO4762</li> </ul> <p>Y 6,0 mm i 57HRC kg ~0,08</p>
---	--	--	---

**Zum Erstellen Ihrer individuellen Formbacke:**  
Schnittzeichnung zum Ermitteln der maximalen Bearbeitungsprofiltiefe  
**If a dedicated jaw is being machined:**  
Sectional drawing to determine the maximum machining depth

für / for TK120531 | TK120531 | TK120529 | TK160554

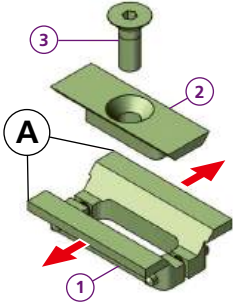
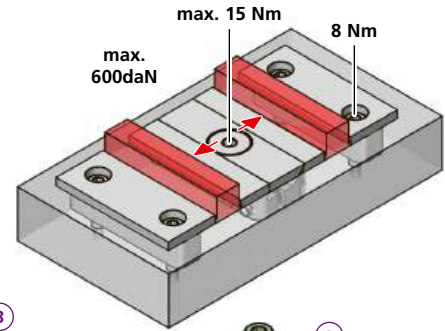

**MS2F58L14W251**

- 1 2x TK120531
- 2 1x TK120227
- 3 1x M8X22DIN7991

i \*

kg ~0,12

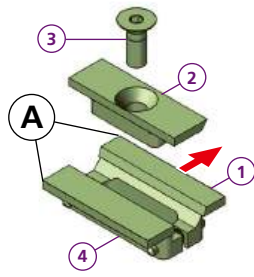

**MS1F58L14W251**

- 1 1x TK120531
- 2 1x TK120721
- 3 1x M8X22DIN7991
- 4 1x TH130566

i \*

kg ~0,12

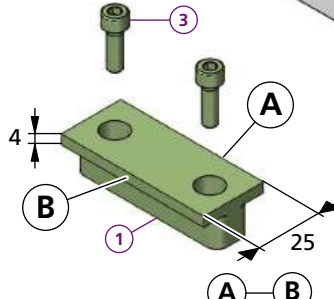

**MANF58-14W25**

- 1 1x TK120529
- 3 2x M5X16ISO4762
- i \*

**MANF58-14F25**

- 1 1x TK150033
- 3 2x M5X16ISO4762
- i HV700 x 0,2mm

kg ~0,11

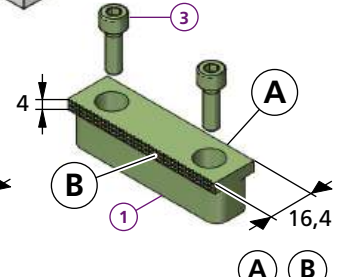

**MANF58-14RF**

- 1 1x TB160563
- 3 2x M5X16ISO4762

i HV700 x 0,2mm

kg ~0,11

**p. 175 Fertigungsmass für die Vorrichtungslatte: / Machining data for the fixture plate:**

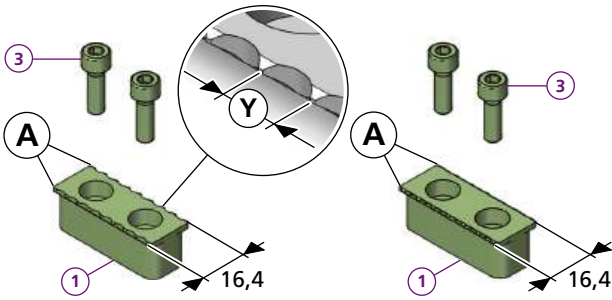

**MAND38-14PRG**

- 1 1x TK150234
- 3 2x M5X16ISO4762
- Y 4,7 mm

i 57HRC

kg ~0,08

**MAND38-14PRG6**

- 1 1x TB150283
- 3 2x M5X16ISO4762
- Y 6,0 mm

i 57HRC

kg ~0,08

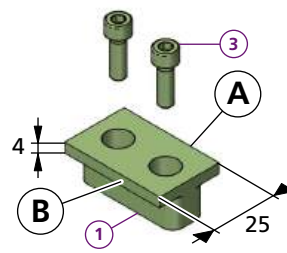

**MANF38-14W25**

- 1 1x TK160554
- 3 2x M5X16ISO4762
- i \*

**MANF38-14F25**

- 1 1x TK160553
- 3 2x M5X16ISO4762
- i HV700 x 0,2mm

kg ~0,08

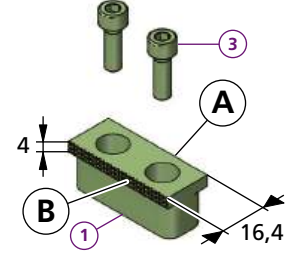

**MANF38-14RF**

- 1 1x TB170062
- 3 2x M5X16ISO4762

i HV700 x 0,2mm

kg ~0,08

**Fertigungsmass für die Vorrichtungslatte**  
**Machining data for the fixture plate**

für / for TB150234 | TB150283 | TK160554 | TK160553 | TB170062

# Spannmodule

## Clamping module MV1F20L35BV1

microCLAMP

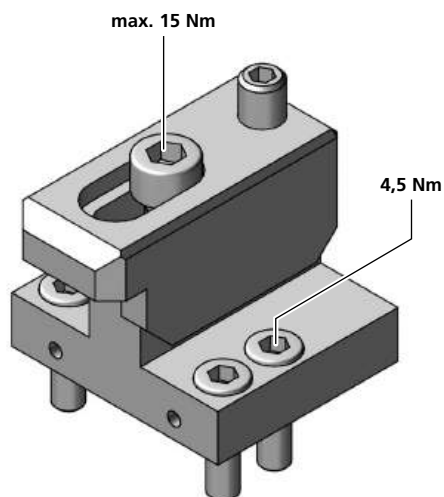
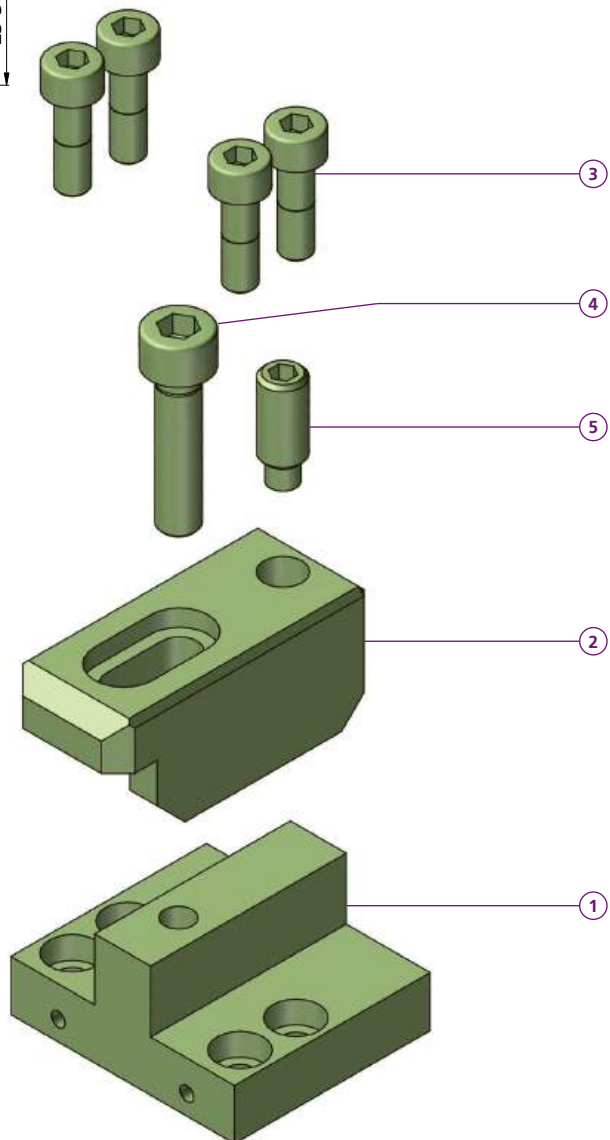
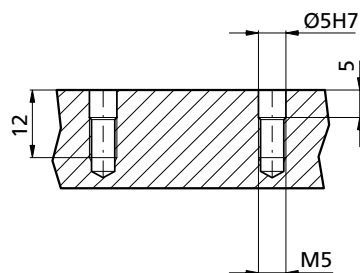
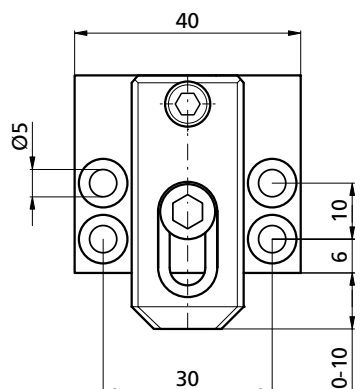
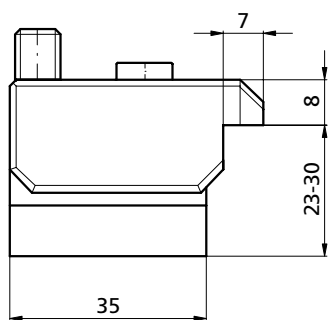
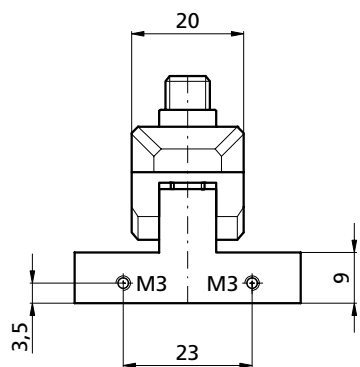

MV1F20L35BV1	
1	1x TF140710
2	1x BV1
3	4x M550
4	1x M6X25ISO4762
5	1x M8x20ISO4028
kg	~0,225

Bestellbeispiel / Ordering example : MV1F20L35BV1

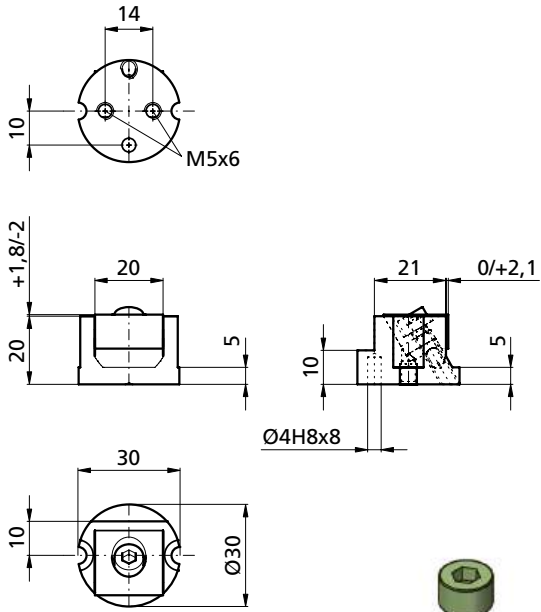

Version 2

Version 1

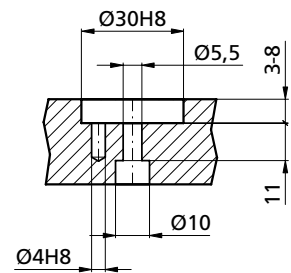
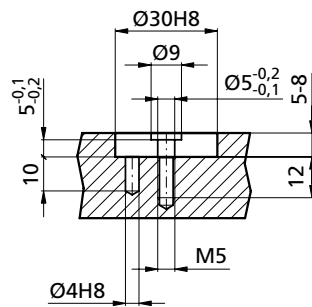
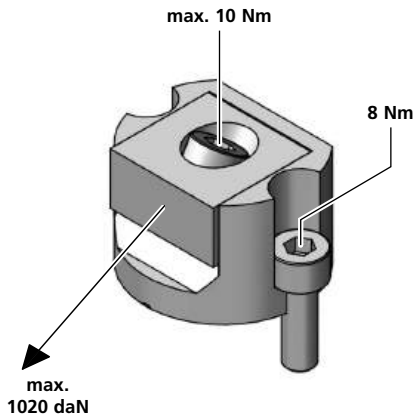
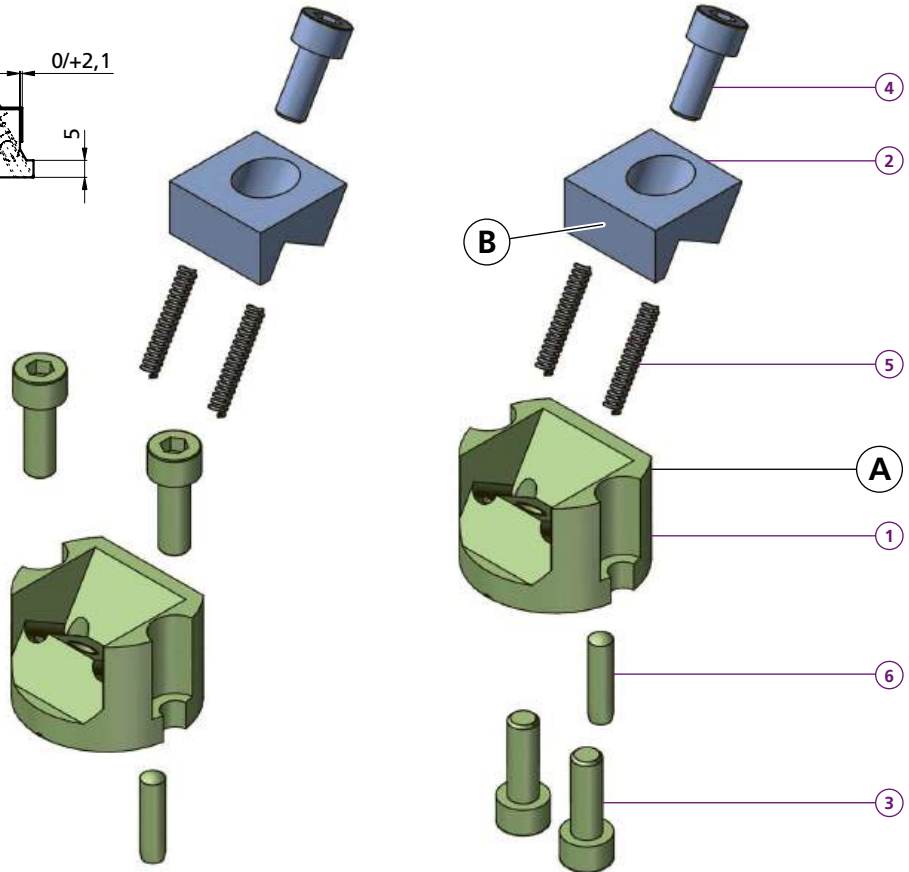

Bestellbeispiel / Ordering example: 1x MR1F30N23-07 & 1x B08

MR1F30N23-07		B07 B08 B09 B09+2 B09+5				
1	1x TF140711					
2	1x					
3	2x M5X16ISO4762					
4	1x M5X12ISO4762					
5	2x FED03018					
6	1x Ø4x14 DIN 6325					
kg	~0,095	kg	~0,02	~0,02	~0,02	~0,02

**B07, B08, B09**

**B09+2, B09+5**

Separat bestellen / Order separately

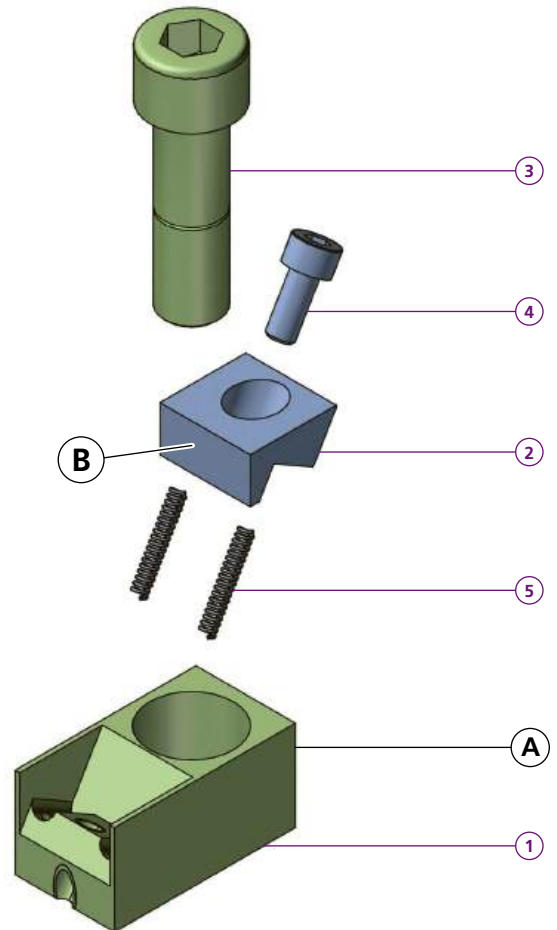
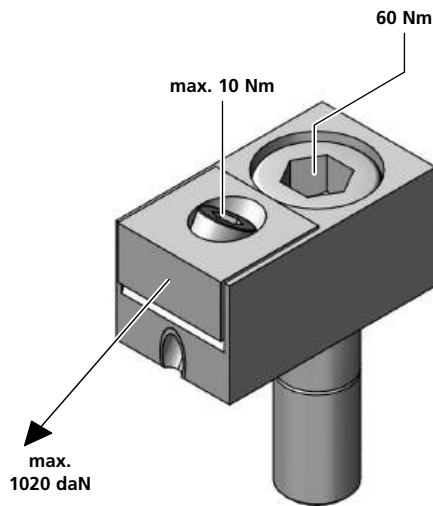
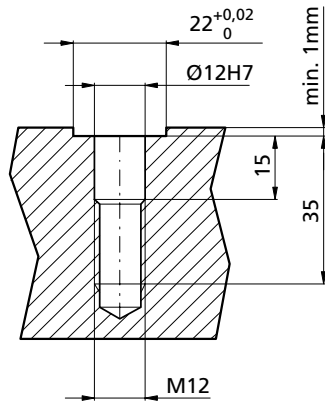
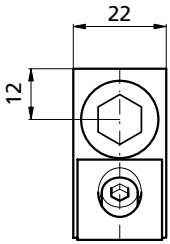
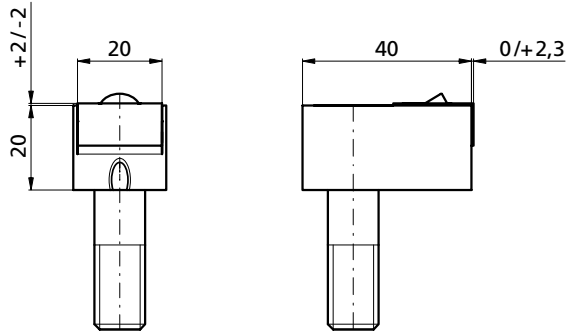

MS1F22N40-07	
1	1x TF140712
2	1x
3	1x TWPAS1240
4	1x M5X12ISO4762
5	2x FED03018
kg	~0,15

	B07	B08	B09	B09+2	B09+5
C	20	20	20	20	20
H	10	10	10	10	10
L	9,5	9,5	9,5	11,5	14,5
D	5,5	5,5	5,5	5,5	5,5
ø	6	6	6	6	6
i	HV700	HV700	*	*	*
	x0,2mm	x0,2mm			
kg	~0,02	~0,02	~0,02	~0,02	~0,02

Bestellbeispiel / Ordering example: 1x MS1F22N40-07 & 1x B08

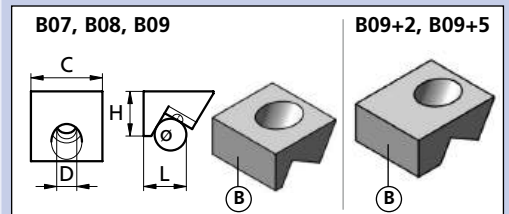

\* = weicher Stahl / soft steel

Separat bestellen / Order separately

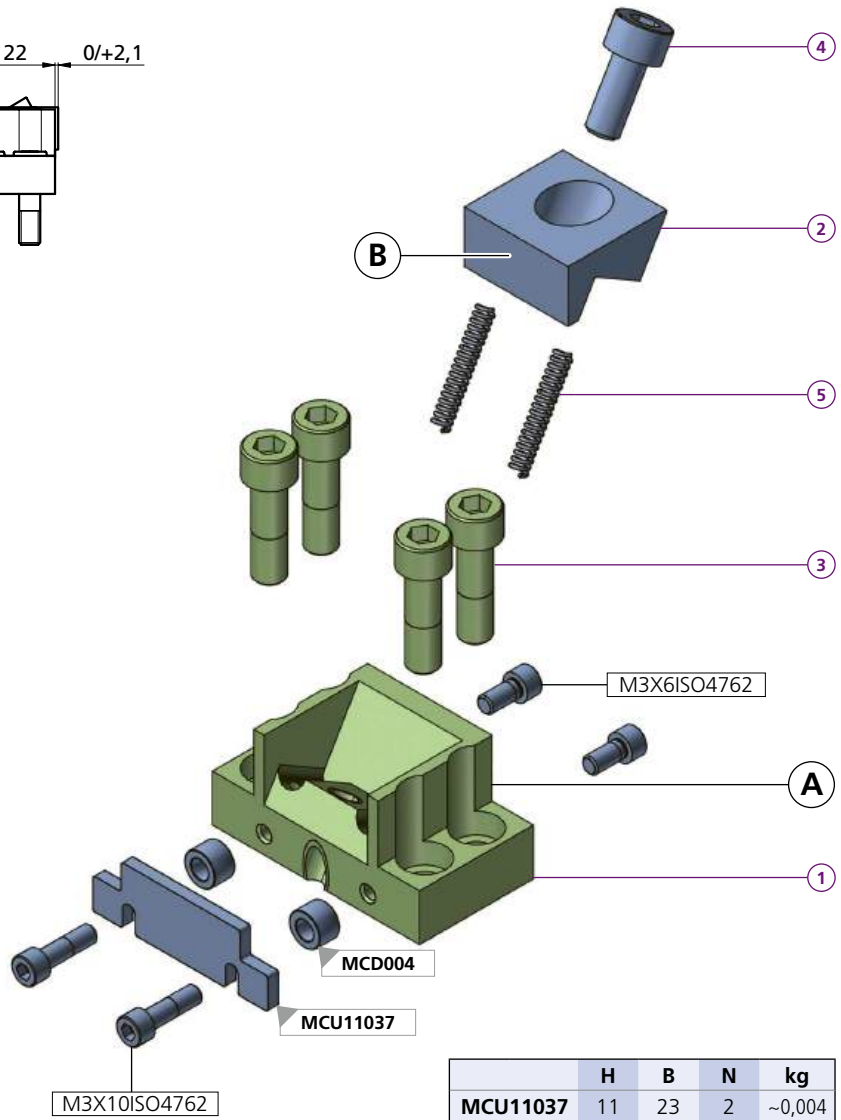
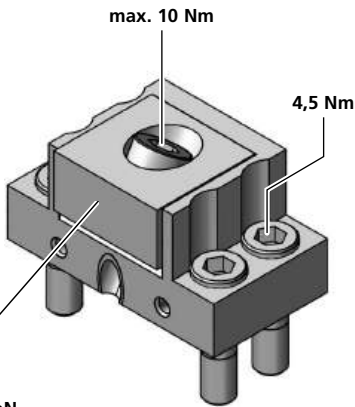
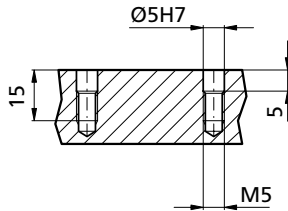
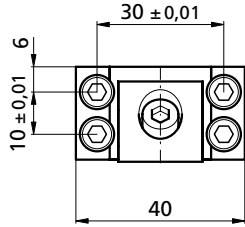
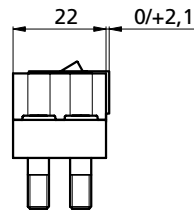
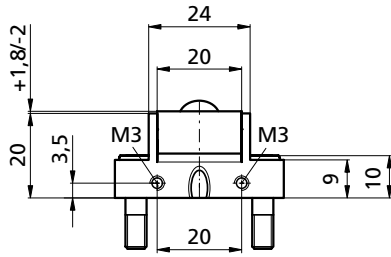

	H	B	N	kg
MCU11037	11	23	2	~0,004
MCU15037	15	23	2	~0,006
MCU18037	18	23	2	~0,008
MCU20037	20	23	2	~0,008
MCU22537	22,5	23	2	~0,008

- 2x M3X10ISO4762
- 2x M3X6ISO4762
- 2x MCD004

**Achtung:** Bei Spannkraften über 400 daN (0,4t) muss das Spannmodul in eine Nut eingelassen werden (Nuttiefe mindestens 1mm)

**Remark:** Using forces higher than 400 daN, clamps must be mounted into a slot (depth minimum 1mm)

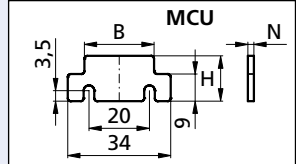
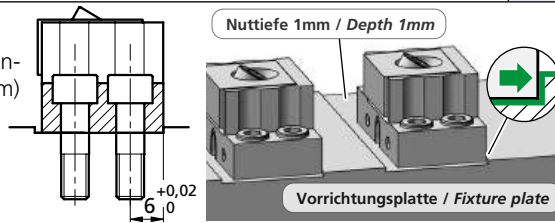

MS1F24N22-07	
1	1x TF140713
MS1R24N22-07	
1	1x TW100172-01
2	1x _____
3	4x MS50
4	1x M5X12ISO4762
5	2x FED03018
kg	~0,125

Bestellbeispiel / Ordering example: 1x MS1F24N22-07 & 1x B08					
	B07	B08	B09	B09+2	B09+5
C	20	20	20	20	20
H	10	10	10	10	10
L	9,5	9,5	9,5	11,5	14,5
D	5,5	5,5	5,5	5,5	5,5
ø	6	6	6	6	6
i	HV700	HV700	*	*	*
	x0,2mm	x0,2mm			
kg	~0,02	~0,02	~0,02	~0,02	~0,02

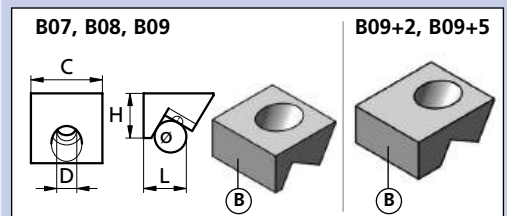

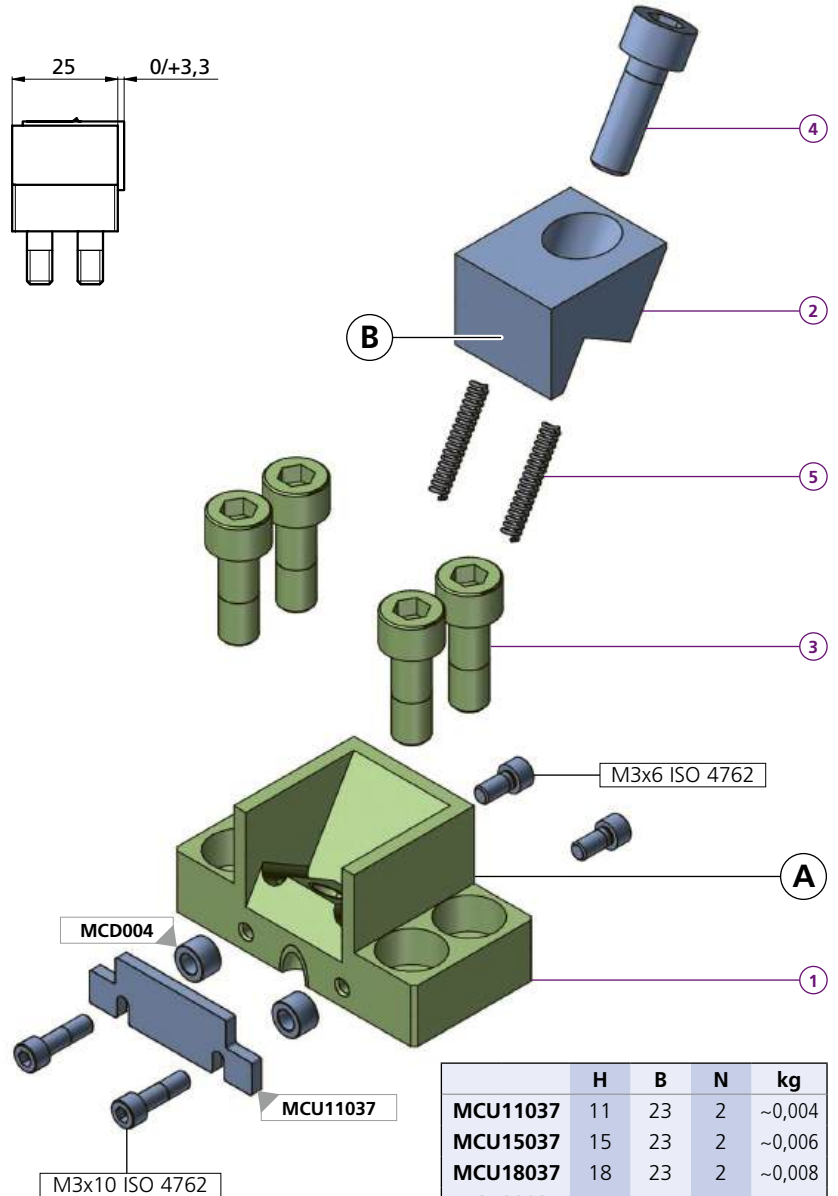
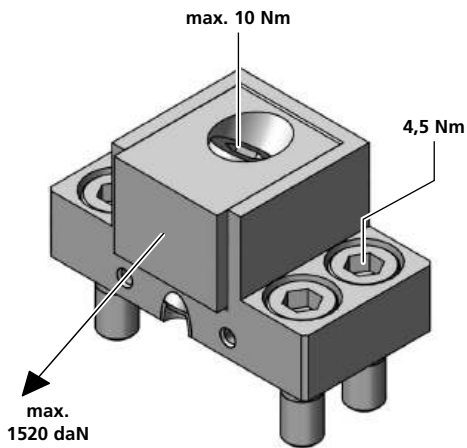
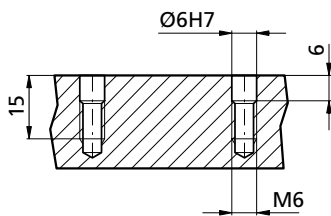
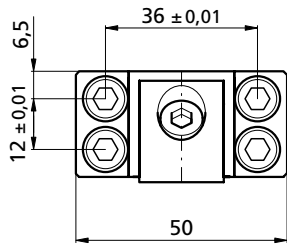
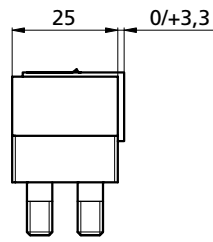
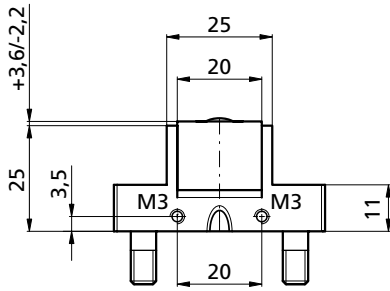

	H	B	N	kg
MCU11037	11	23	2	~0,004
MCU15037	15	23	2	~0,006
MCU18037	18	23	2	~0,008
MCU20037	20	23	2	~0,008
MCU22537	22,5	23	2	~0,008

- 2x M3X10ISO4762
- 2x M3X6ISO4762
- 2x MCD004

**Achtung:** Bei Spannkraften über 400 daN (0,4t) muss das Spannmodul in eine Nut eingelassen werden (Nuttiefe mindestens 1mm)

**Remark:** Using forces higher than 400 daN, clamps must be mounted into a slot (depth minimum 1mm)

MS1F25N25-13	
1	1x TF140714
MS1R25N25-13	
1	1x TF140715
2	1x
3	4x MS60
4	1x M6X16ISO4762
5	2x FED03018
kg	~0,165

Bestellbeispiel / Ordering example: 1x MS1F25N25-13 & 1x B14

	B13	B14	B15	B16
C	20	20	20	20
H	16	16	16	16
L	13,8	13,8	13,8	19
D	6,5	6,5	6,5	6,5
e	10	10	10	10
i	HV700	HV700	*	*
	x0,2mm	x0,2mm		
kg	~0,05	~0,05	~0,05	~0,06

\* = weicher Stahl / soft steel

# MS1R/F35N14-01

# MS1F35N22-01

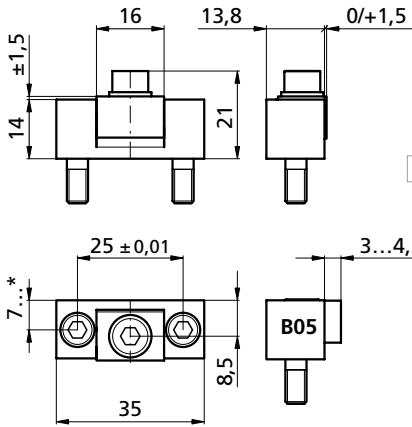

MS1F35N14-01

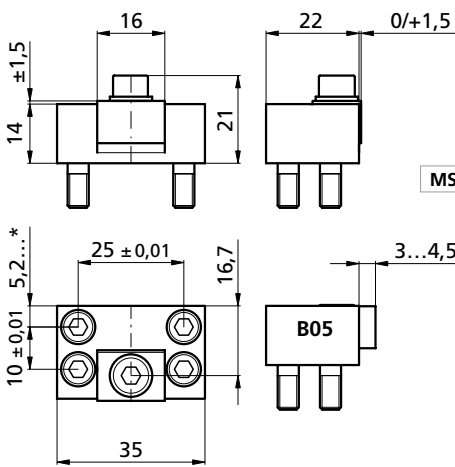
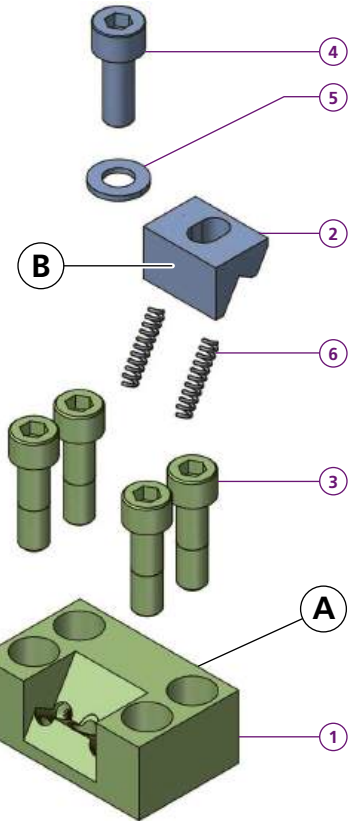
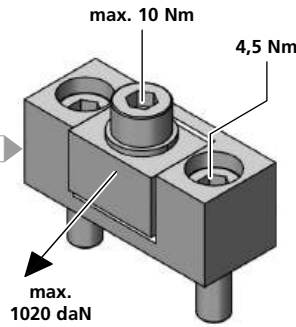

MS1F35N22-01

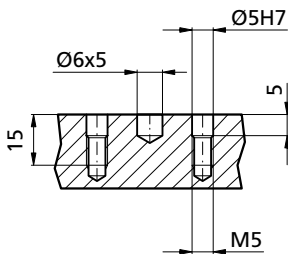
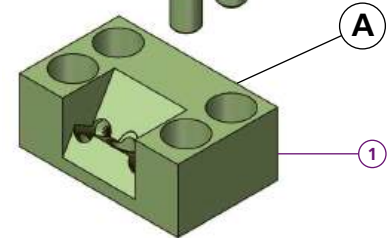
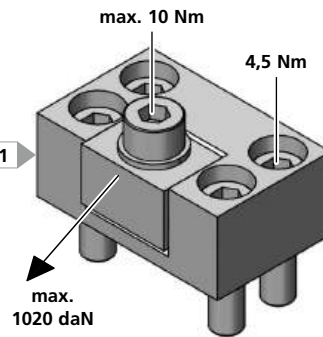

**Beim Einsatz der Backe B05(R) Jaw B05(R) in use**  
 Nachbearbeitung am Modul, falls *If a stroke of 1,1mm to 1,5mm*  
 der gesamte Backenhub (1,1mm bis *is required the module must be*  
 1,5mm) benötigt wird. *machined according to this sketch.*

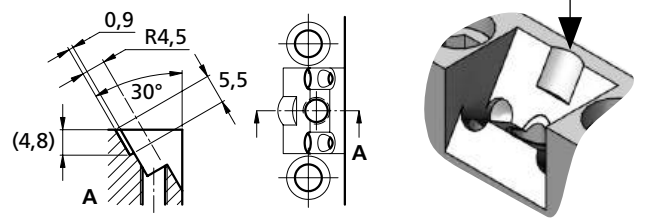

**Achtung:** Bei Spannkraften über 400 daN (0,4t) muss das Spannmodul in eine Nut eingelassen werden (Nuttiefe mindestens 1mm)

**Remark:** Using forces higher than 400 daN, clamps must be mounted into a slot (depth minimum 1mm)

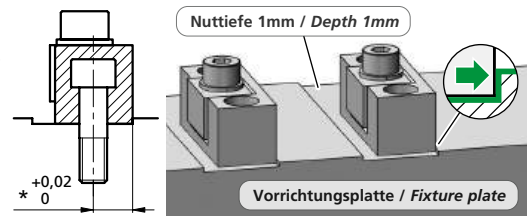

<b>MS1F35N14-01</b>	<b>A</b>
1x TF140718	
<b>MS1R35N14-01</b>	<b>B</b>
1x TK190150	
1x	
2x MS50	
1x M5X14ISO4762	
1x 5x10x1DIN125A	
2x FED02813	
kg ~0,05	
<b>MS1F35N22-01</b>	<b>A</b>
1x TF140719	
4x MS50	
kg ~0,08	

Bestellbeispiel / Ordering example: 1x MS1F35N14-01 & 1x B02

	B01	B02	B03	B04	B05	B05R
<b>C</b>	16	16	16	16	16	16
<b>H</b>	10	10	10	10	10	10
<b>L</b>	8	8	11	8	10	10
<b>D</b>	5,5	5,5	5,5	5,5	5,2	5,2
<b>e</b>	4	4	4	4	4	4
<b>i</b>	HV700	HV700	*	Messing	HV700	HV700
	x0,2mm	x0,2mm		Laiton	x0,2mm	x0,2mm
kg	~0,01	~0,01	~0,014	~0,012	~0,014	~0,014

M5X10DIN6912

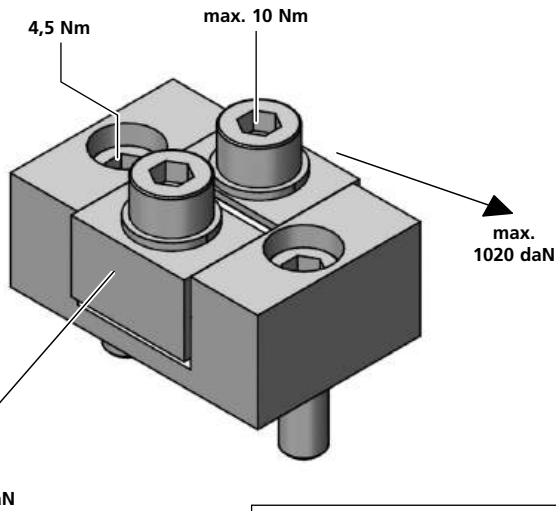
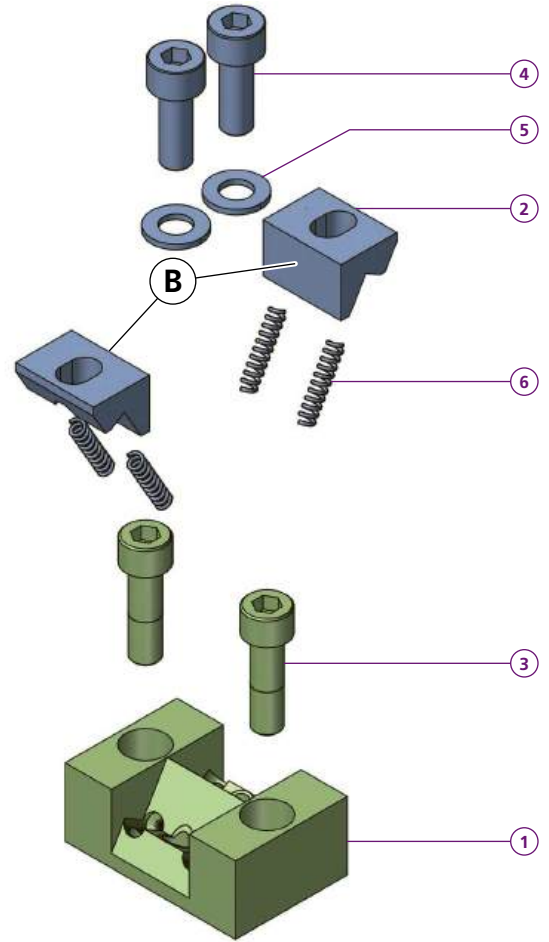
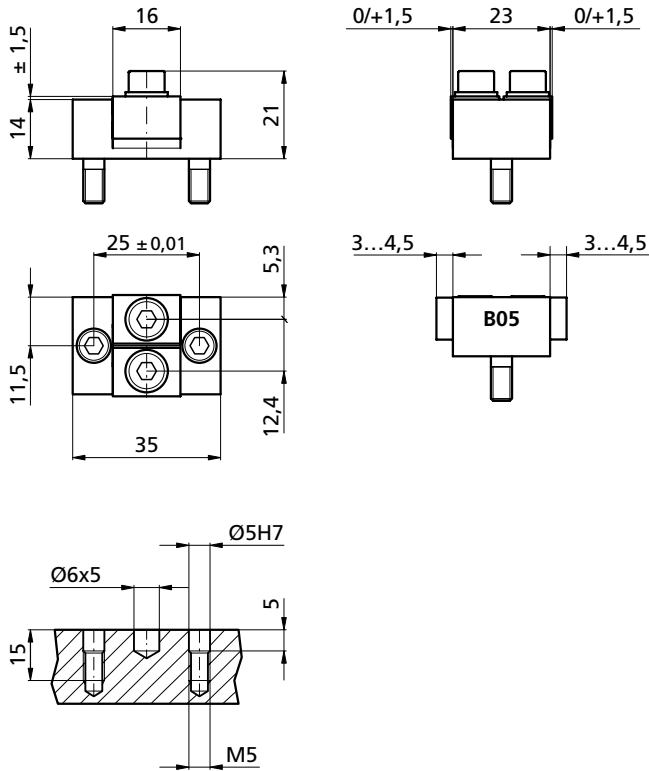

**Beim Einsatz der Backe B05(R) Jaw B05(R) in use**  
 Nachbearbeitung am Modul, falls If a stroke of 1,1mm to 1,5mm  
 der gesamte Backenhub (1,1mm bis is required the module must be  
 1,5mm) benötigt wird. machined according to this sketch.

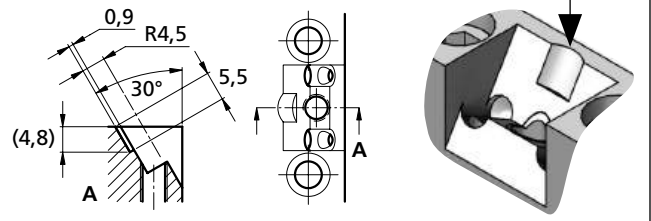

**Achtung:** Bei Spannkraften über 400 daN (0,4t) muss das Spannmodul in eine Nut eingelassen werden (Nuttiefe mindestens 1mm)

**Remark:** Using forces higher than 400 daN, clamps must be mounted into a slot (depth minimum 1mm)

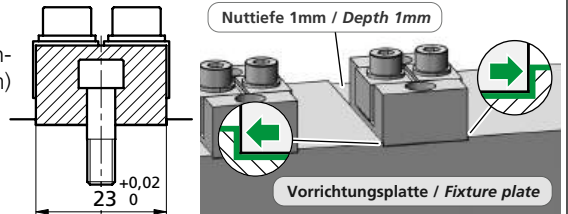

Bestellbeispiel / Ordering example: 1x MS2X35N23-01 & 2x B02

MS2X35N23-01	
1	1x TF140720
2	2x —
3	2x MS50
4	2x M5X14ISO4762
5	2x 5x10x1DIN125A
6	4x FED02813
kg	~0,085

	B01	B02	B03	B04	B05	B05R
C	16	16	16	16	16	16
H	10	10	10	10	10	10
L	8	8	11	8	10	10
D	5,5	5,5	5,5	5,5	5,2	5,2
e	4	4	4	4	4	4
i	HV700 x0,2mm	HV700 x0,2mm	*	Messing Laiton	HV700 x0,2mm	HV700 x0,2mm
kg	~0,01	~0,01	~0,014	~0,012	~0,014	~0,014

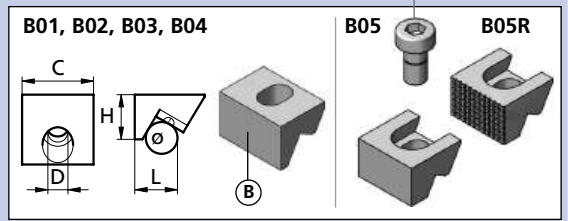

\* = weicher Stahl / soft steel

Separat bestellen / Order separately



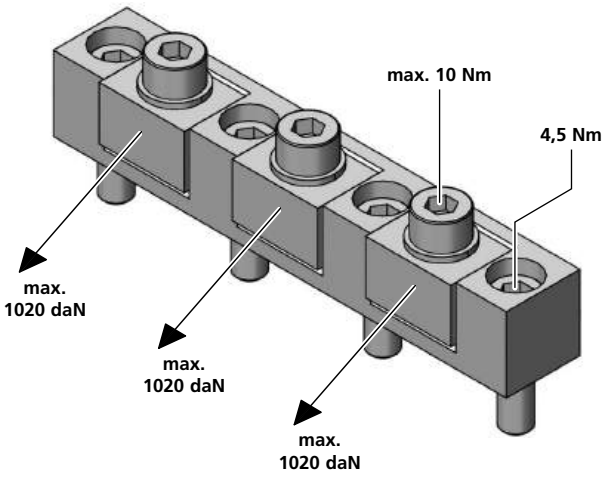
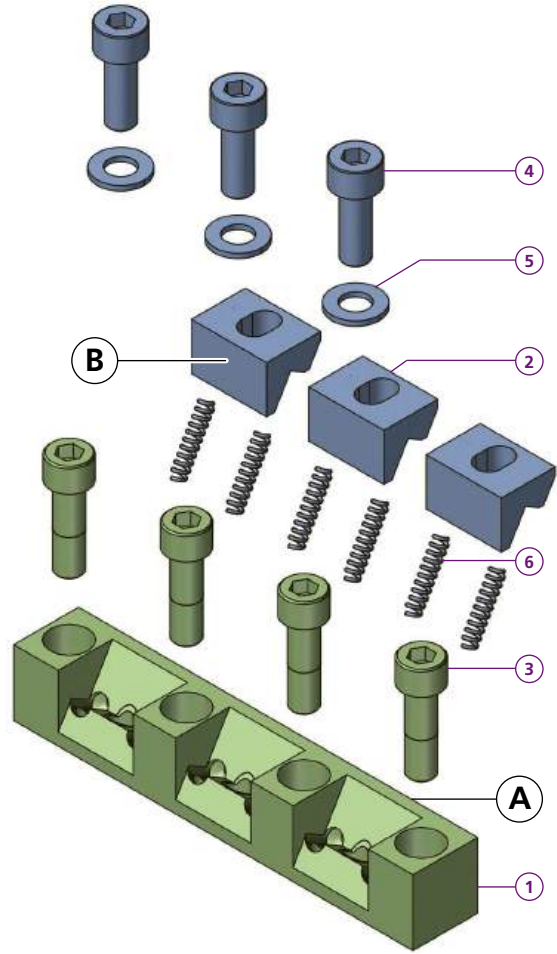
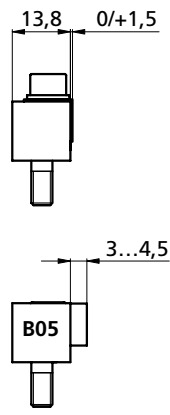
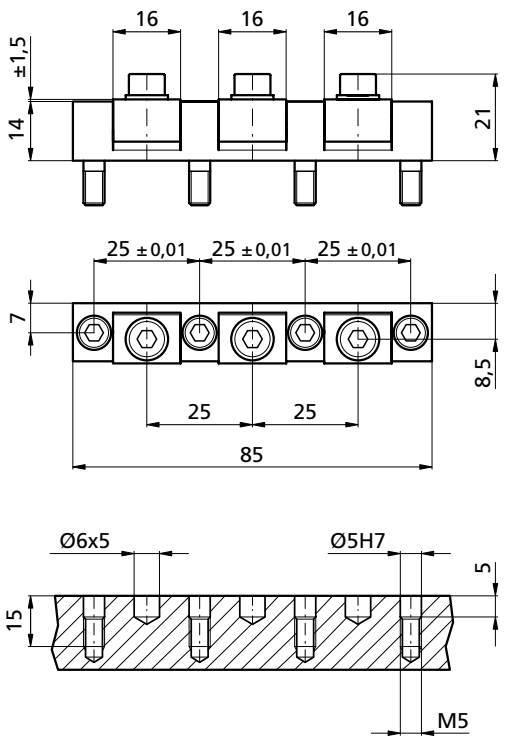

**Beim Einsatz der Backe B05(R) Jaw B05(R) in use**  
 Nachbearbeitung am Modul, falls If a stroke of 1,1mm to 1,5mm  
 der gesamte Backenhub (1,1mm bis is required the module must be  
 1,5mm) benötigt wird. machined according to this sketch.

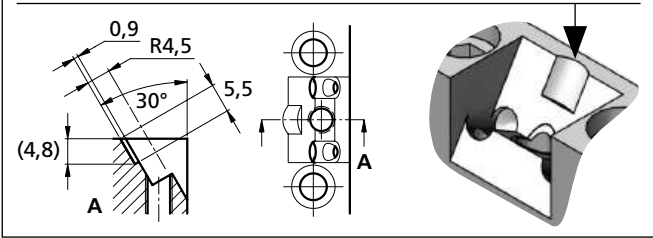

**Achtung:** Bei Spannkraften über 400 daN (0,4t) muss das Spannmodul in eine Nut eingelassen werden (Nuttiefe mindestens 1mm)  
**Remark:** Using forces higher than 400 daN, clamps must be mounted into a slot (depth minimum 1mm)

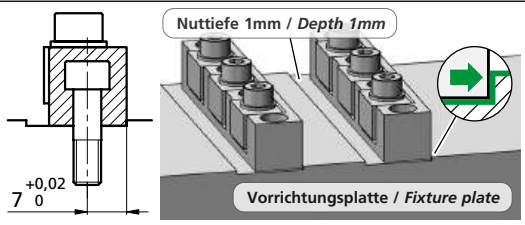

Bestellbeispiel / Ordering example: 1x MS3F85N14-01 & 3x B02

MS3F85N14-01	B01	B02	B03	B04	B05	B05R
1x TH160579	16	16	16	16	16	16
3x	10	10	10	10	10	10
4x MS50	8	8	11	8	10	10
3x M5X14ISO4762	5,5	5,5	5,5	5,5	5,2	5,2
3x 5x10x1DIN125A	4	4	4	4	4	4
6x FED02813	HV700	HV700	*	Messing	HV700	HV700
	x0,2mm	x0,2mm		Laiton	x0,2mm	x0,2mm
kg ~0,125	kg ~0,01	kg ~0,01	kg ~0,014	kg ~0,012	kg ~0,014	kg ~0,014

M5X10DIN6912

B01, B02, B03, B04: C, H, D, L, Ø, i

B05, B05R: C, H, D, L, Ø, i

\* = weicher Stahl / soft steel

Separat bestellen / Order separately

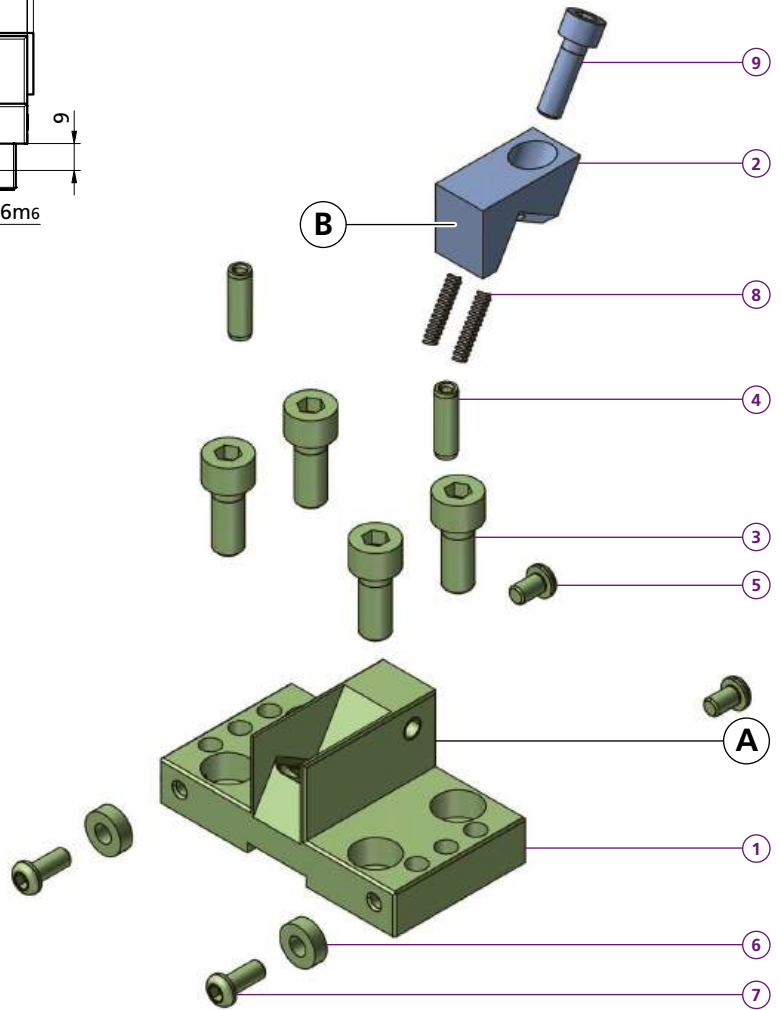
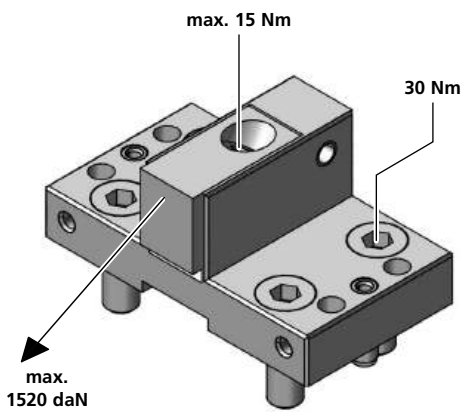
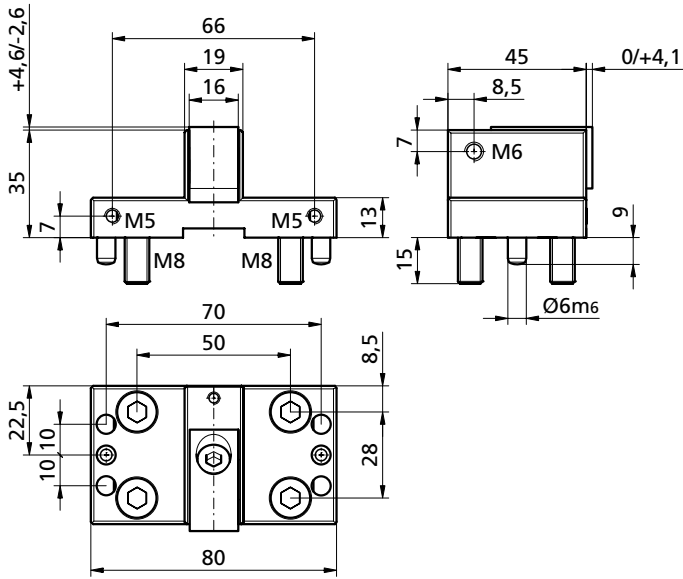

	<b>A</b>
<b>VS1F19N35-20</b>	
1x TF150029	
<b>VS1R19N35-20</b>	
1x TF140723	
1x	
4x M8X20ISO4762	
2x CCBO0802	
2x M5X8ISO7380	
2x CCD004	
2x M5X12ISO7380	
2x FED0418	
1x M6X20ISO4762	
kg ~0,505	

**B** Bestellbeispiel / Ordering example: 1x VS1R19N35-20 & 1x B21

	B20	B21	B22
<b>C</b>	16	16	16
<b>H</b>	20	20	20
<b>L</b>	19	19	19
<b>D</b>	6,5	6,5	6,5
<b>e</b>	12	12	12
<b>i</b>	HV700 x0,2mm	HV700 x0,2mm	*
kg	~0,011	~0,011	~0,011

**B20, B21, B22**

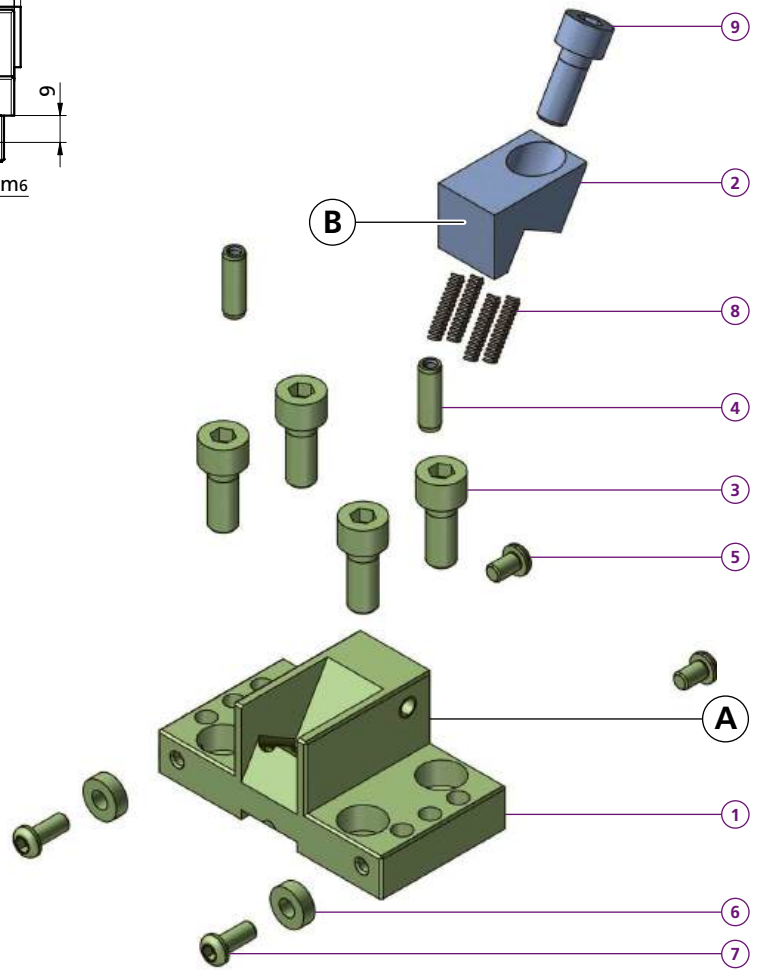
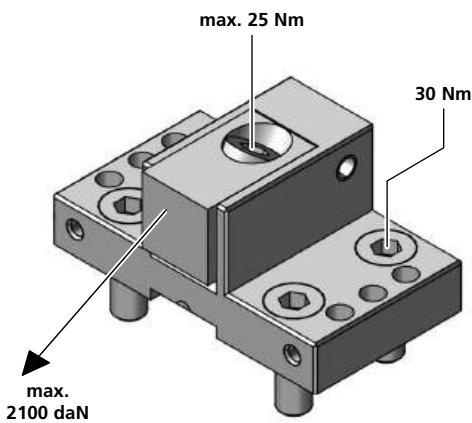
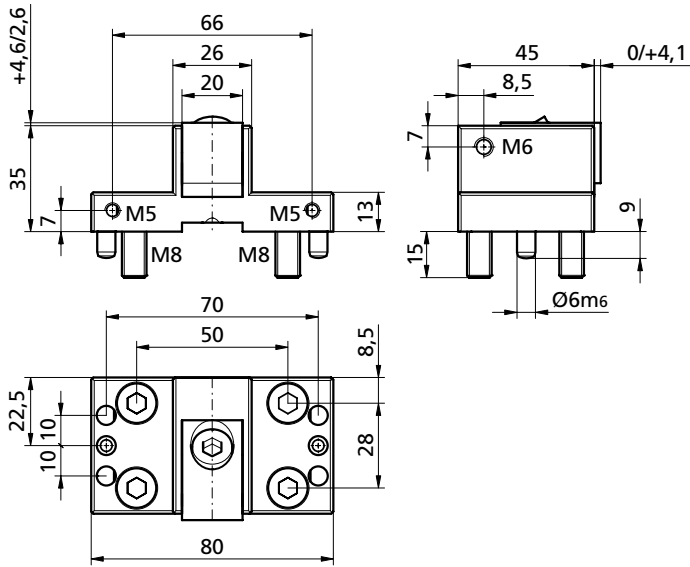

VS1R26N35-26	
1	1x TF140725
2	1x
3	4x M8X20ISO4762
4	2x CCBO0802
5	2x M5X8ISO7380
6	2x CCD004
7	2x M5X12ISO7380
8	4x FED0418
9	1x M8X20ISO4762
kg	~0,55

Bestellbeispiel / Ordering example: 1x VS1R26N35-26 & 1x B27

	B26	B27	B28
C	20	20	20
H	20	20	20
L	19	19	19
D	9	9	9
ø	12	12	12
i	HV700 x0,2mm	HV700 x0,2mm	*
kg	~0,064	~0,064	~0,064

**B26, B27, B28**

\* = weicher Stahl / soft steel



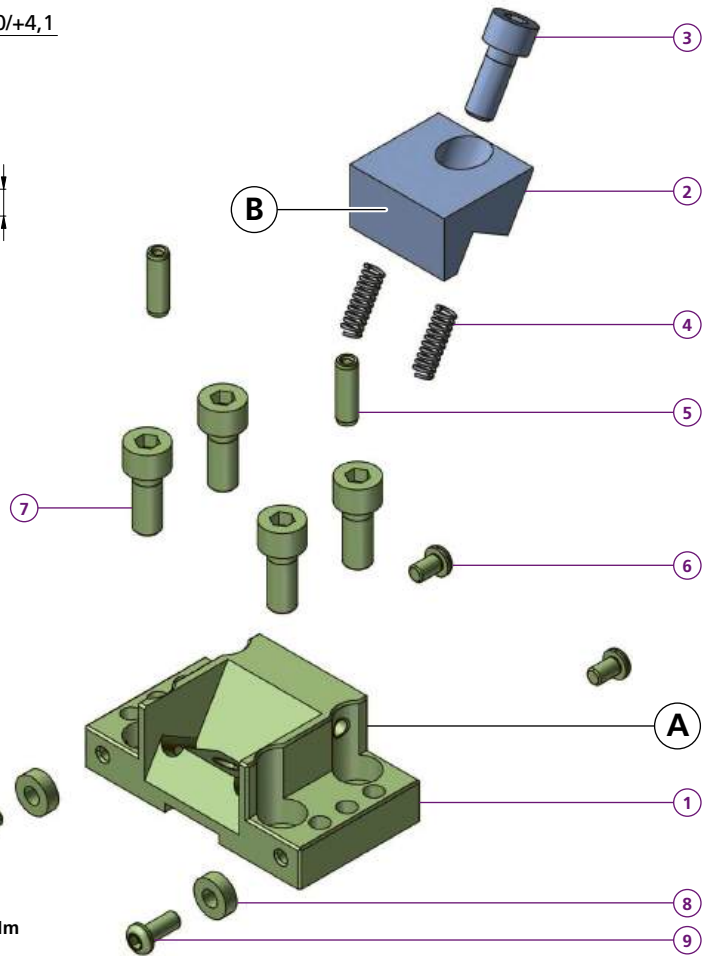
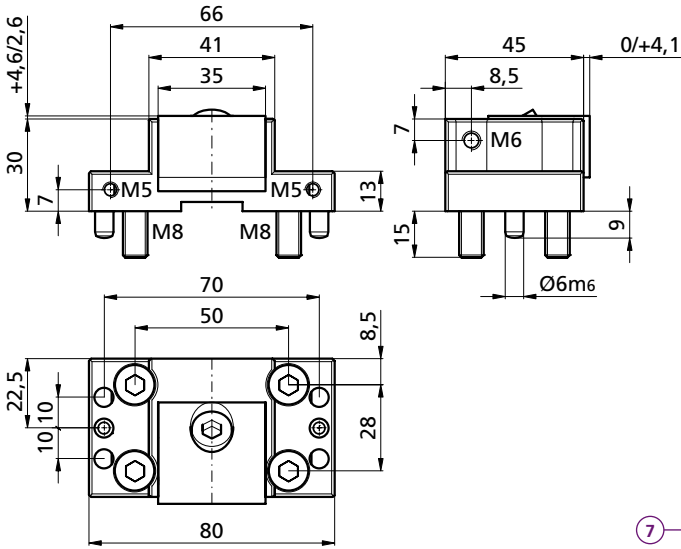

- VS1F41N30-60**
- 1x TF140729
- VS1R41N30-60**
- 1x TF140730
- 1x
- 1x M8X20ISO4762
- 2x FED0618
- 2x CCBO0802
- 2x M5X8ISO7380
- 4x M8X20ISO4762
- 2x CCD004
- 2x M5X12ISO7380
- kg ~0,58

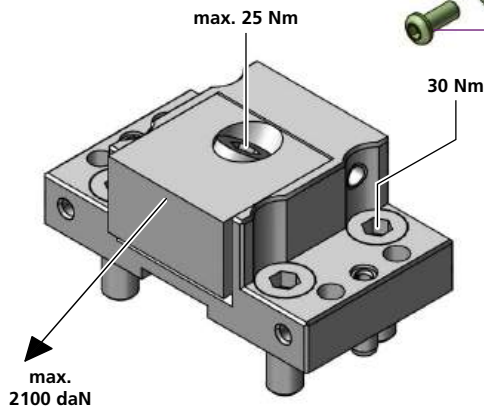

Bestellbeispiel / Ordering example: 1x VS1R41N30-60 & 1x B61

	B58	B60	B61	B62	B62HM	B65	B66	B67	B68	B77	B79F	B79R
C	35	35	35	35	35	35	35	35	35	35	35	35
H	20	20	20	20	20	20	20	20	20	20	20	20
L	26	19	19	19	19	19	19	24	26	22	25	25
D	9	9	9	9	9	9	9	9	9	9	9	9
o	12	12	12	12	12	12	12	12	12	12	12	12
i	ALU	56HRC	56HRC	*	HM	HV700	HV700	HV700	*	56HRC	HV700	HV700
kg	~0,07	~0,12	~0,12	~0,12	~0,12	~0,12	~0,12	~0,14	~0,15	~0,12	~0,18	~0,18

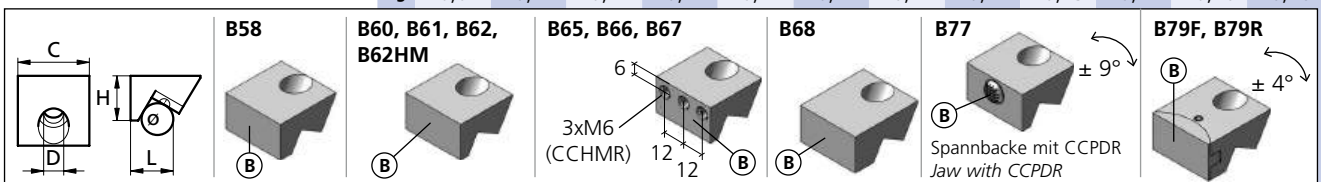

\* = weicher Stahl / soft steel

HM = Hartmetallbeschichtet / Carbide coated

ALU = ENAW-7022

# VS1R/F80N30-36

# VS1R80N50-36

microCLAMP

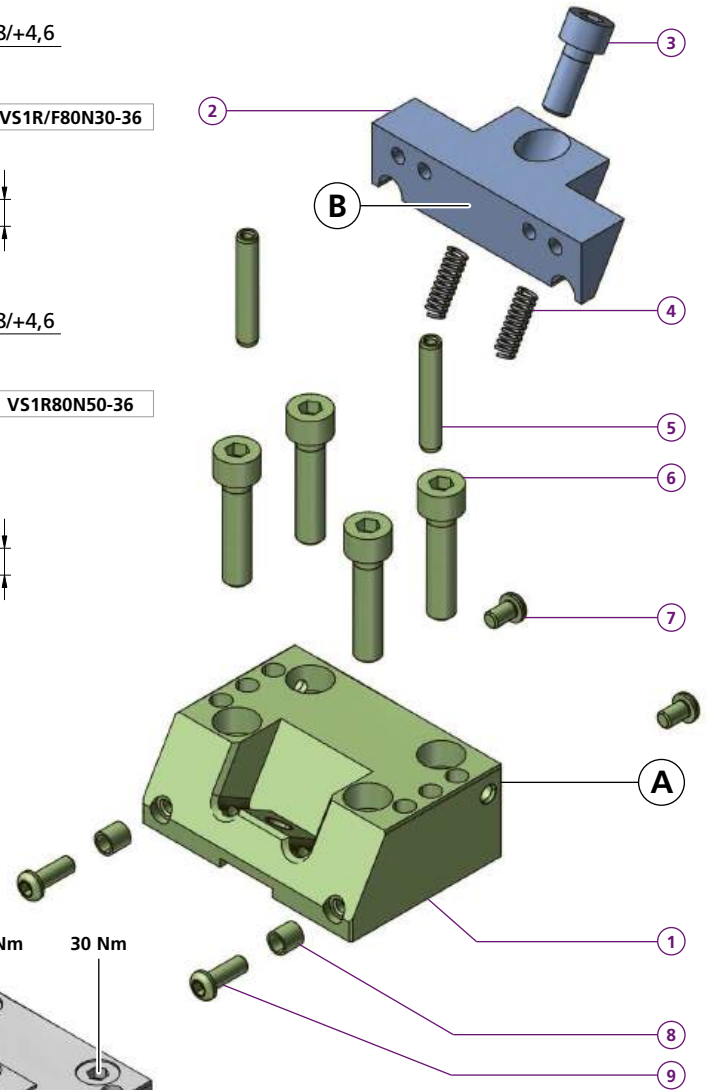
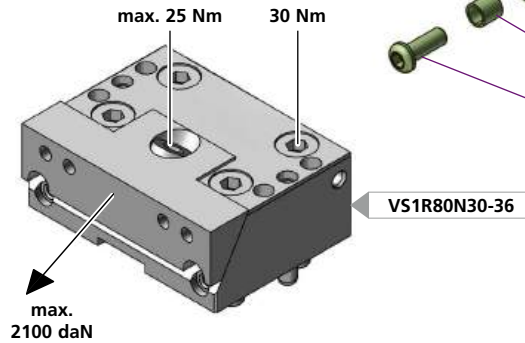
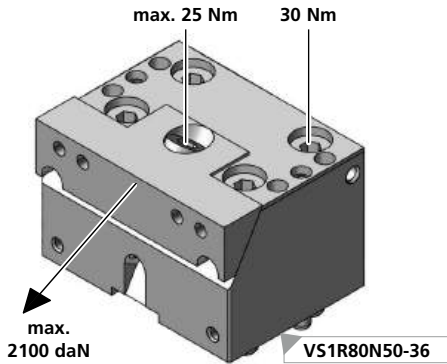
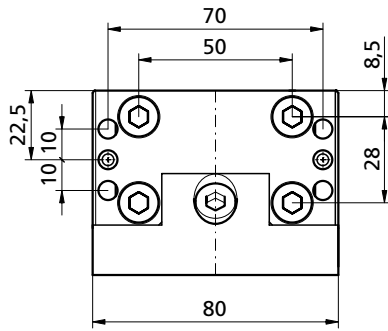
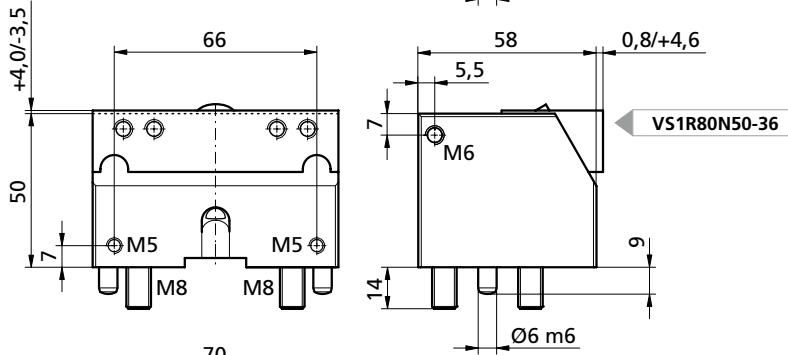
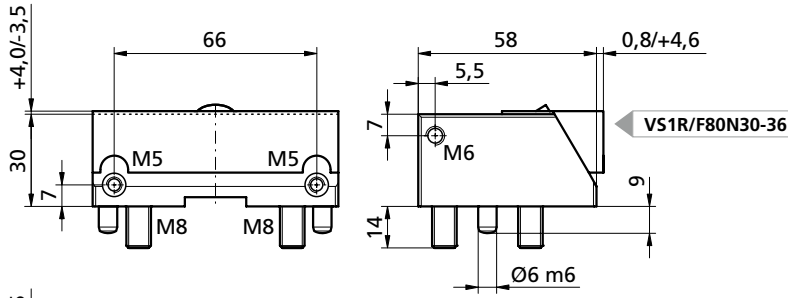

<b>VS1F80N30-36</b>	<b>VS1R80N30-36</b>	<b>VS1R80N50-36</b>
1x TF140733	1x TF140734	1x TF140742
1x M8X20ISO4762	4x FED0618	2x CCBO0803
4x M8X35ISO4762	2x M5X8ISO4762	4x M8X55ISO4762
2x CCD007	2x M5X16ISO7380	2x CCD007
2x M5X12ISO7380		2x M5X12ISO7380
kg ~1,2	kg ~1,9	

Bestellbeispiel / Ordering example: 1x VS1R80N30-36 & 1x B37

	B36	B37	B38
<b>C</b>	80	80	80
<b>H</b>	20	20	20
<b>L</b>	19	19	19
<b>D</b>	9	9	9
<b>e</b>	12	12	12
<b>i</b>	HV700 x0,2mm	HV700 x0,2mm	*
<b>kg</b>	~0,18	~0,18	~0,18

**B36, B37, B38**

Separat bestellen / Order separately

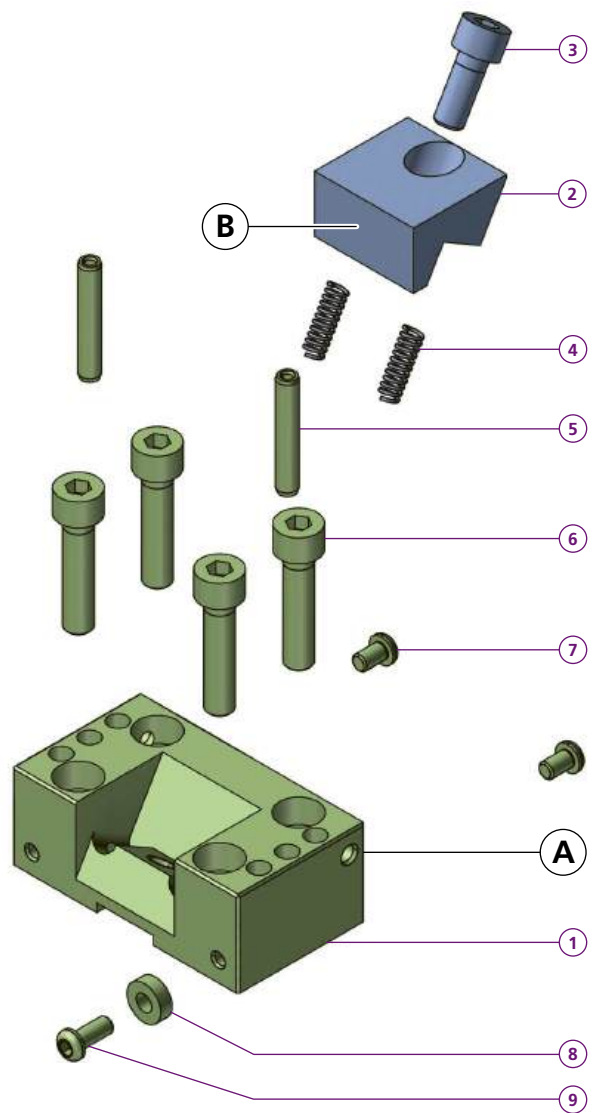
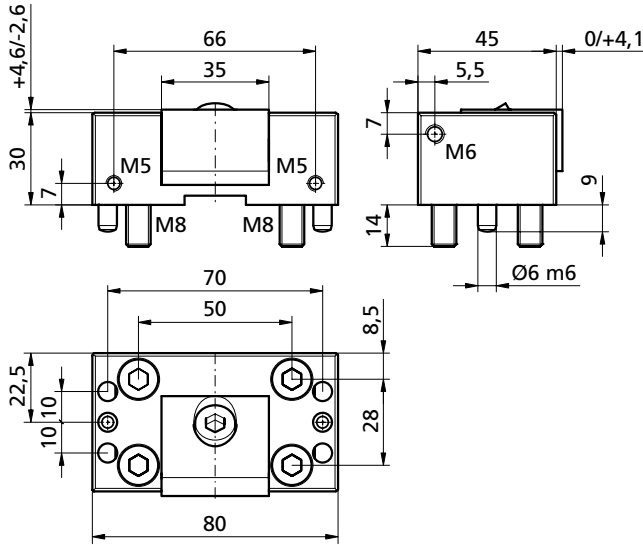

- VS1F80N30-60**
- 1 1x TF140735
- VS1R80N30-60**
- 1 1x TF140736
  - 2 1x
  - 3 1x M8X20ISO4762
  - 4 2x FED0618
  - 5 2x CCBO0801
  - 6 4x M8X35ISO4762
  - 7 2x M5X8ISO7380
  - 8 2x CCD004
  - 9 2x M5X12ISO7380
- kg ~0,74

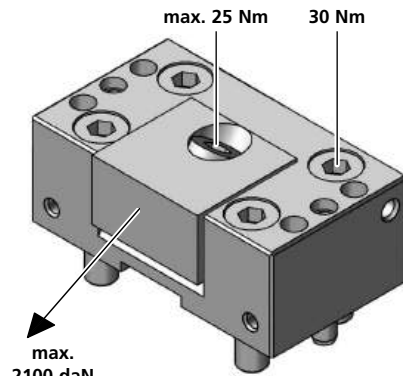

Bestellbeispiel / Ordering example: 1x VS1F80N30-60 & 1x B61

	B58	B60	B61	B62	B62HM	B65	B66	B67	B68	B77	B79F	B79R
C	35	35	35	35	35	35	35	35	35	35	35	35
H	20	20	20	20	20	20	20	20	20	20	20	20
L	26	19	19	19	19	19	19	24	26	22	25	25
D	9	9	9	9	9	9	9	9	9	9	9	9
ø	12	12	12	12	12	12	12	12	12	12	12	12
i	ALU	56HRC	56HRC	*	HM	HV700 x0,2mm	HV700 x0,2mm	HV700 x0,2mm	*	56HRC	HV700 x0,2mm	HV700 x0,2mm
kg	~0,07	~0,12	~0,12	~0,12	~0,12	~0,12	~0,12	~0,14	~0,15	~0,12	~0,18	~0,18

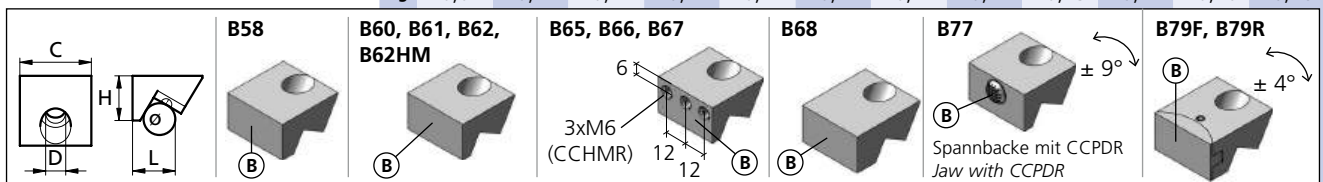

\* = weicher Stahl / soft steel

HM = Hartmetallbeschichtet / Carbide coated

ALU = ENAW-7022

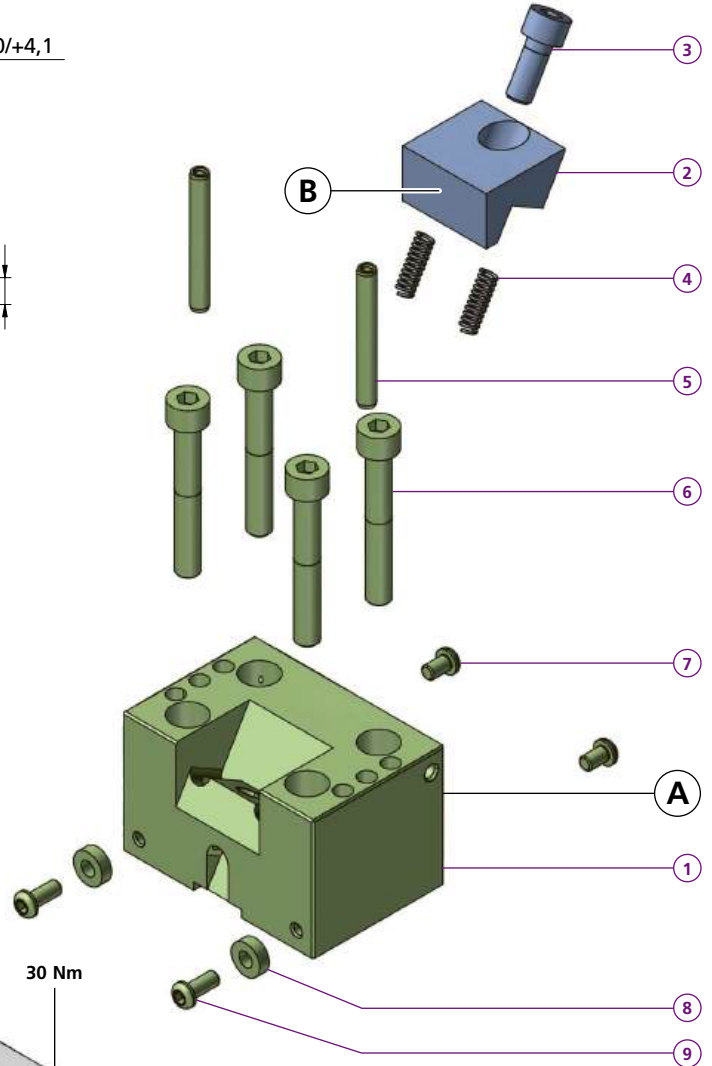
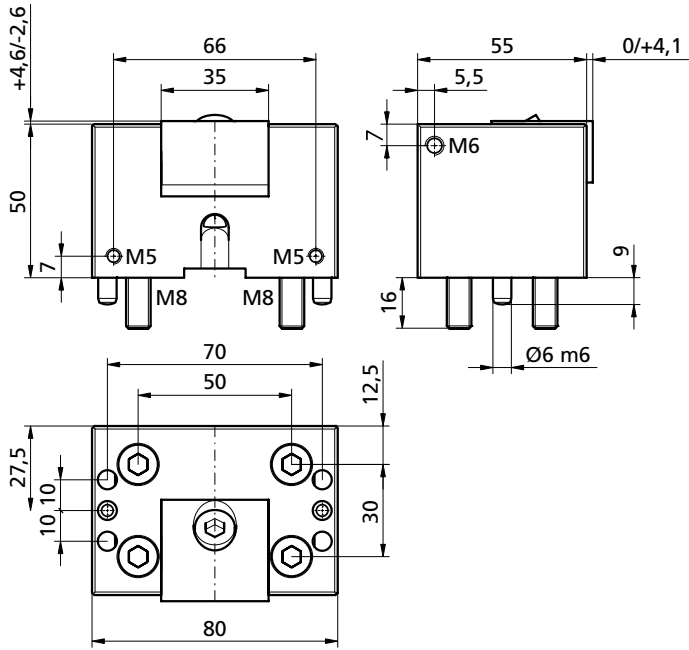

**VS1R80N50-60**

1	1x	TF140737
2	1x	
3	1x	M8X20ISO4762
4	2x	FED0618
5	2x	CCBO0803
6	4x	M8X55ISO4762
7	2x	M5X8ISO7380
8	2x	CCD004
9	2x	M5X12ISO7380
kg		~1,6

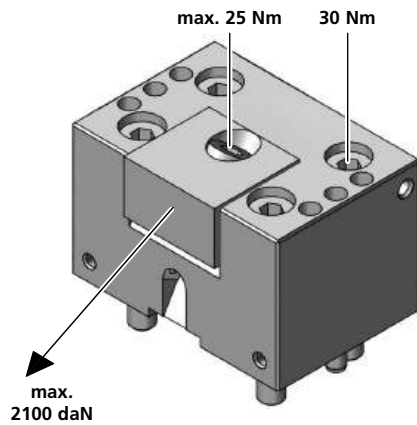

Bestellbeispiel / Ordering example: 1xVS1R80N50-60 & 1x B61

	B58	B60	B61	B62	B62HM	B65	B66	B67	B68	B69	B77	B79F	B79R
C	35	35	35	35	35	35	35	35	35	35	35	35	35
H	20	20	20	20	20	20	20	20	20	25	20	20	20
L	26	19	19	19	19	19	19	24	26	22	22	25	25
D	9	9	9	9	9	9	9	9	9	9	9	9	9
ø	12	12	12	12	12	12	12	12	12	12	12	12	12
i	ALU	56HRC	56HRC	*	HM	HV700 x0,2mm	HV700 x0,2mm	HV700 x0,2mm	*	*	56HRC	HV700 x0,2mm	HV700 x0,2mm
kg	~0,07	~0,12	~0,12	~0,12	~0,12	~0,12	~0,12	~0,14	~0,15	~0,15	~0,12	~0,18	~0,18

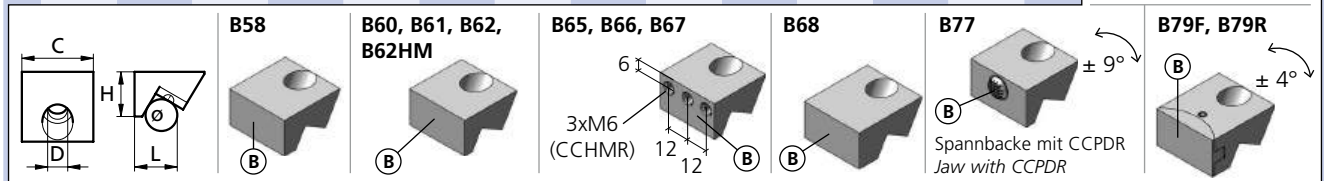
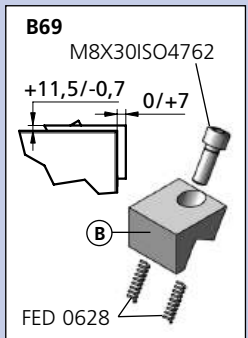

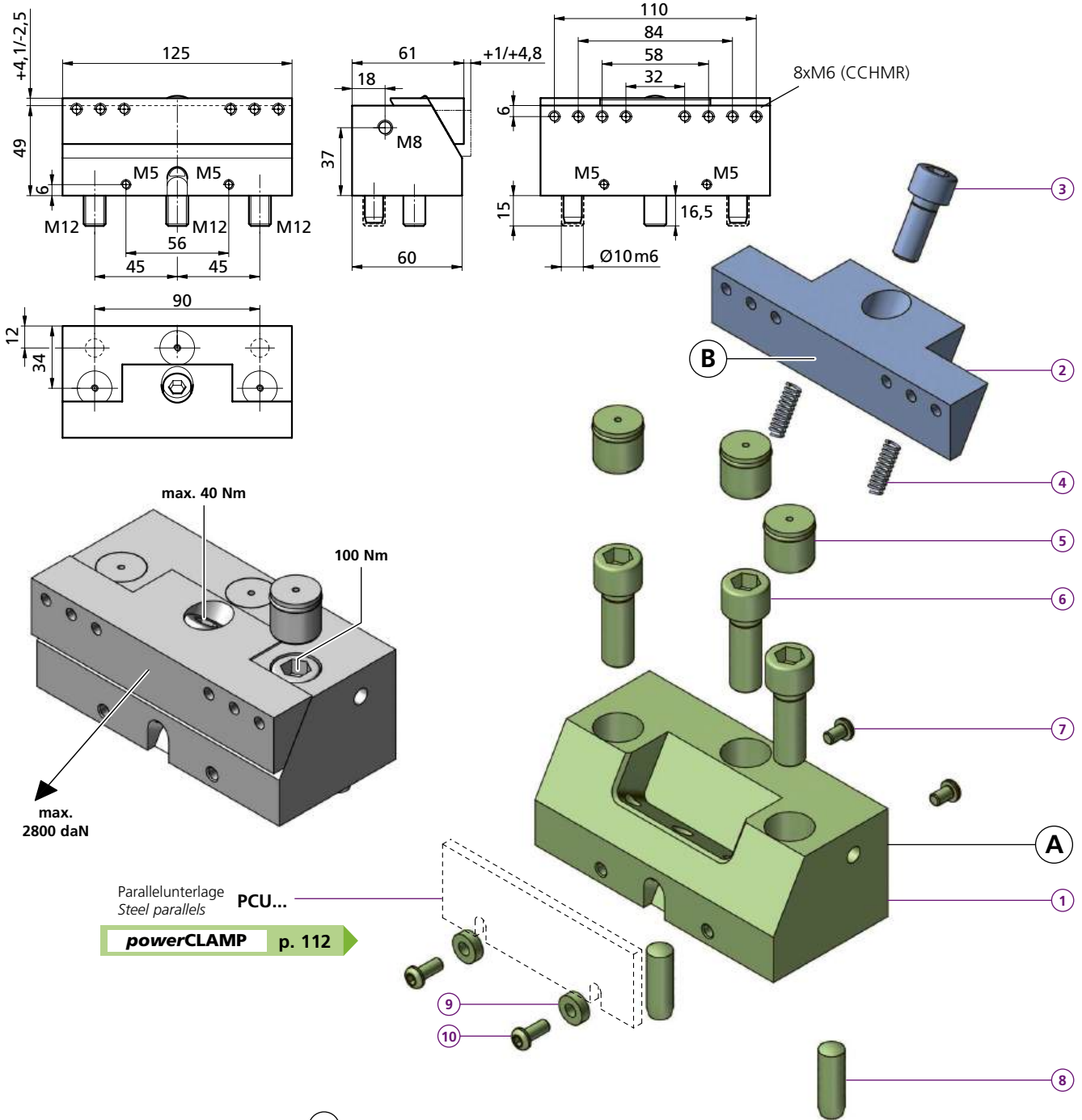

Parallelunterlage  
Steel parallels  
PCU...  
**powerCLAMP** p. 112

Bestellbeispiel / Ordering example: 1x VS1R125N49-95 & 1x B96

	B95	B96	B97	B98	B99
<b>VS1F125N49-95</b>					
1x TF140738					
<b>VS1R125N49-95</b>					
1x TF140739					
1x					
1x M10X25ISO4762					
2x FED0618					
3x PCPF16L18Alu					
3x M12X35ISO4762					
3x M5X8ISO7380					
2x 10m6x30 DIN6325					
2x CCD004					
2x M5X12ISO7380					
kg	~2,6				
<b>C</b>	125	125	125	125	125
<b>H</b>	25	25	25	25	25
<b>L</b>	23	23	23	30	23
<b>D</b>	11	11	11	11	11
<b>e</b>	15	15	15	15	15
<b>i</b>	HV700 x0,2mm	HV700 x0,2mm	*	*	HV700 x0,2mm
kg	~0,45	~0,45	~0,45	~0,63	~0,45

**B95, B96, B97, B99**

**B98**

\* = weicher Stahl / soft steel

Separat bestellen / Order separately

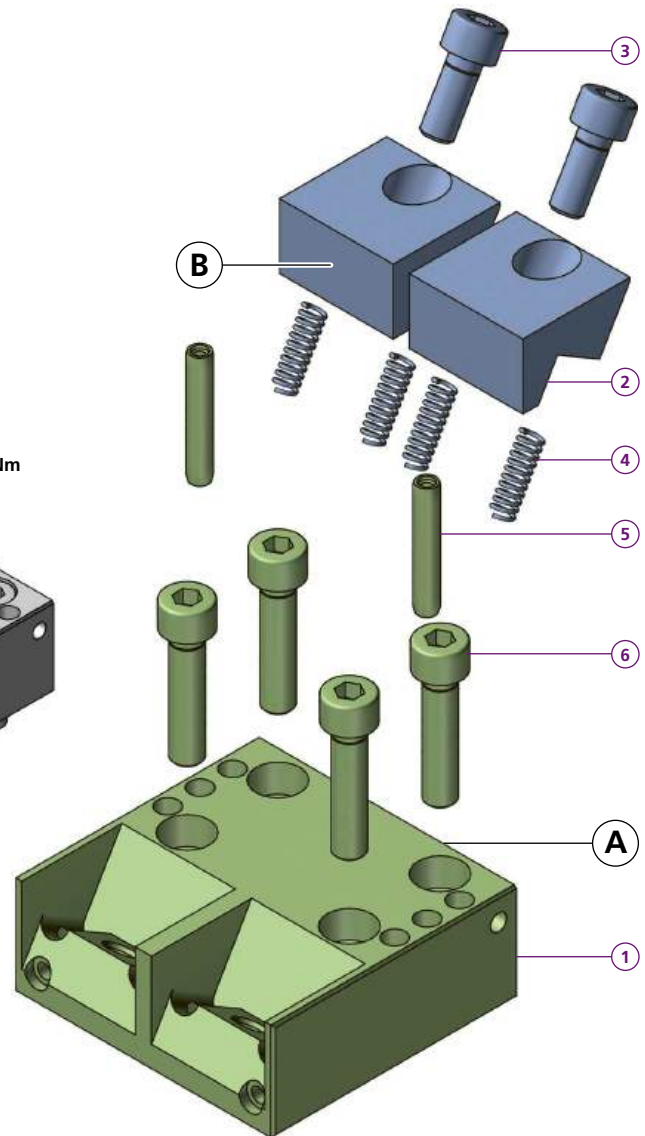
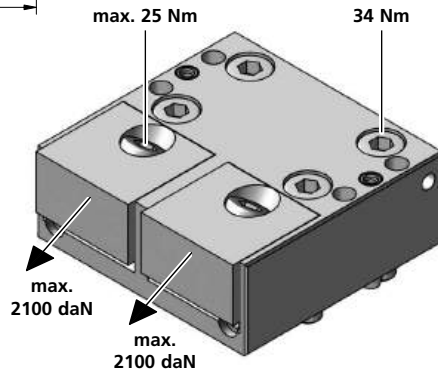
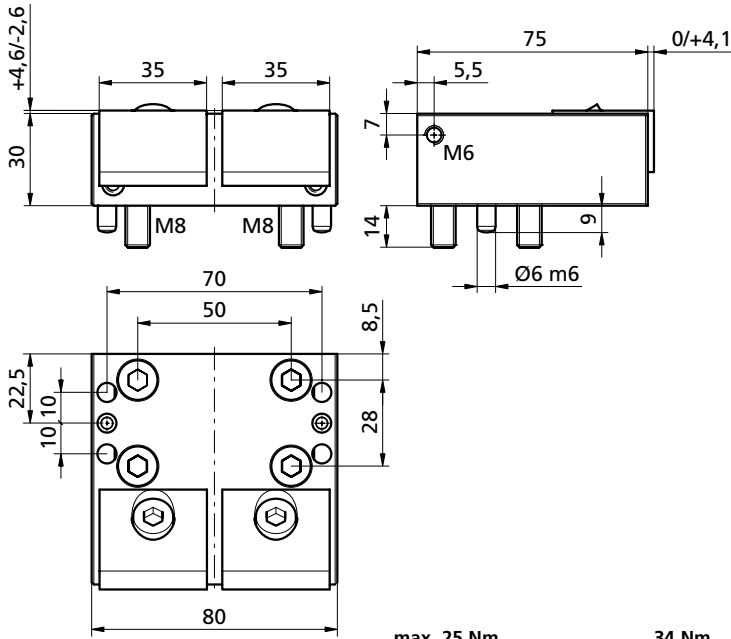

**A**

<b>VS2R80N30-60</b>	
1	1x TF140740
2	2x
3	2x M8X20ISO4762
4	4x FED0618
5	2x CCBO0801
6	4x M8X35ISO4762
kg	~1,3

**B** Bestellbeispiel / Ordering example: 1x VS2R80N30-60 & 2x B61

	B58	B60	B61	B62	B62HM	B65	B66	B67	B68	B77	B79F	B79R
<b>C</b>	35	35	35	35	35	35	35	35	35	35	35	35
<b>H</b>	20	20	20	20	20	20	20	20	20	20	20	20
<b>L</b>	26	19	19	19	19	19	19	24	26	22	25	25
<b>D</b>	9	9	9	9	9	9	9	9	9	9	9	9
<b>o</b>	12	12	12	12	12	12	12	12	12	12	12	12
<b>i</b>	ALU	56HRC	56HRC	*	HM	HV700 x0,2mm	HV700 x0,2mm	HV700 x0,2mm	*	56HRC	HV700 x0,2mm	HV700 x0,2mm
<b>kg</b>	~0,07	~0,12	~0,12	~0,12	~0,12	~0,12	~0,12	~0,14	~0,15	~0,12	~0,18	~0,18

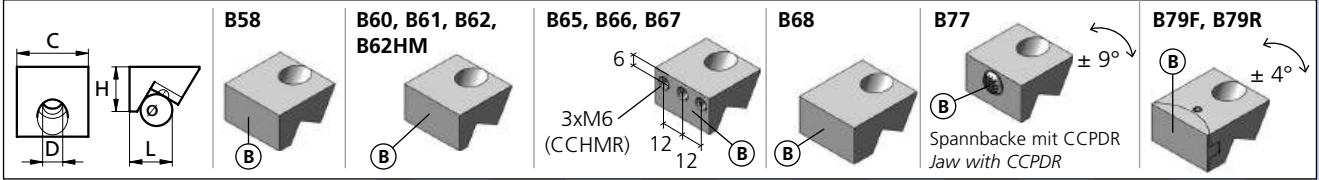

Separat bestellen / Order separately

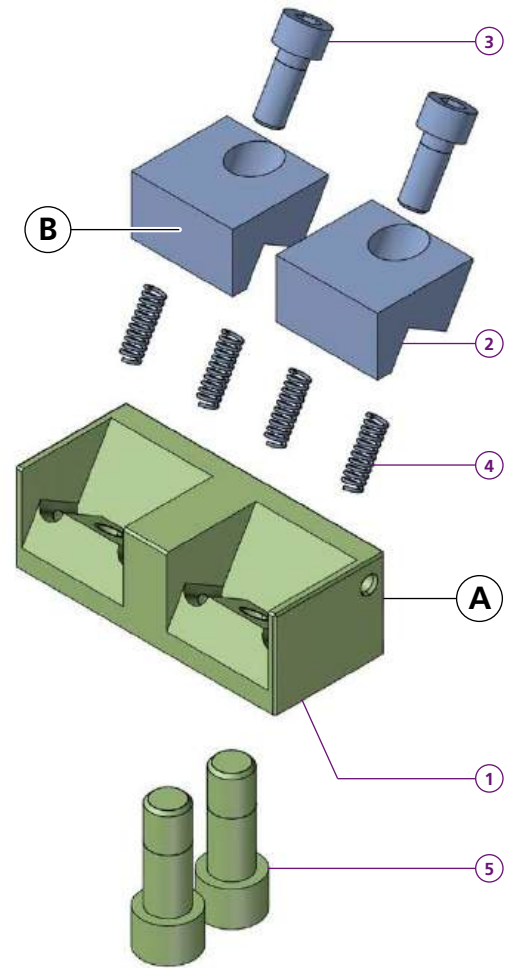
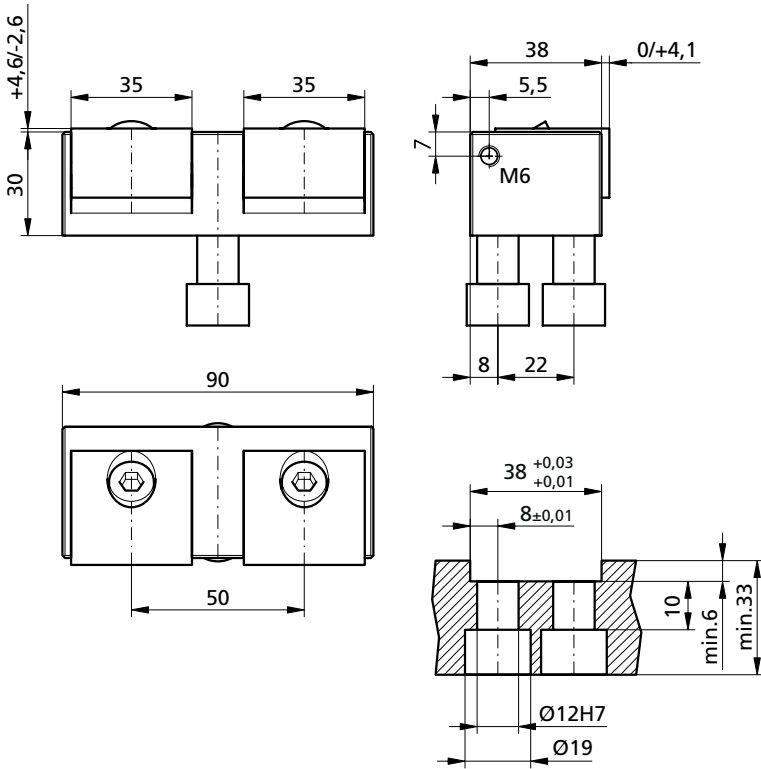

VS2F90N30-60	
1x	TF140741
2x	
2x	M8X20ISO4762
4x	FED0618
2x	TWPAS1232
kg	~0,85

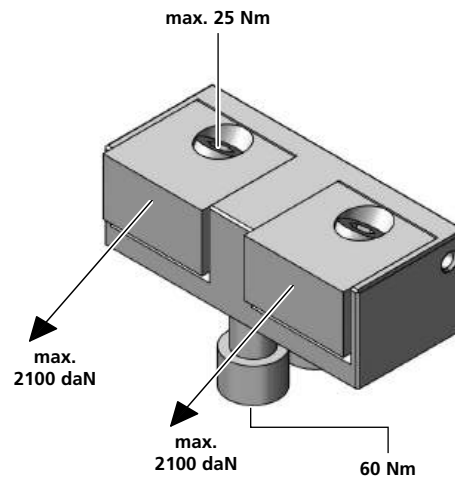

Bestellbeispiel / Ordering example: 1x VS2F90N30-60 & 2x B61

	B58	B60	B61	B62	B62HM	B65	B66	B67	B68	B77	B79F	B79R
C	35	35	35	35	35	35	35	35	35	35	35	35
H	20	20	20	20	20	20	20	20	20	20	20	20
L	26	19	19	19	19	19	19	24	26	22	25	25
D	9	9	9	9	9	9	9	9	9	9	9	9
ø	12	12	12	12	12	12	12	12	12	12	12	12
i	ALU	56HRC	56HRC	*	HM	HV700	HV700	HV700	*	56HRC	HV700	HV700
		x0,2mm	x0,2mm			x0,2mm	x0,2mm	x0,2mm			x0,2mm	x0,2mm
kg	~0,07	~0,12	~0,12	~0,12	~0,12	~0,12	~0,12	~0,14	~0,15	~0,12	~0,18	~0,18

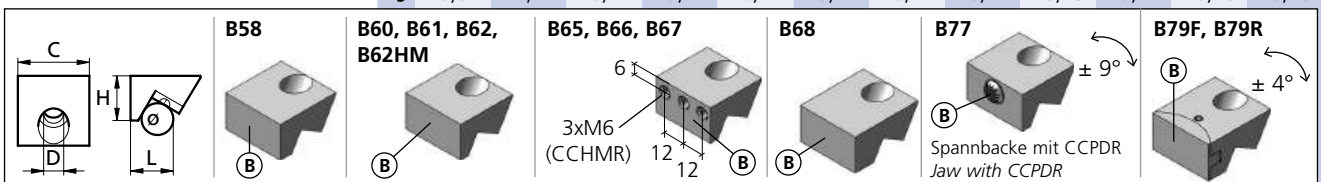

\* = weicher Stahl / soft steel

HM = Hartmetallbeschichtet / Carbide coated

ALU = ENAW-7022

MS1R/F35L14-152

\*MS1R/F35L14-150\* (Alte Version / Old Version)

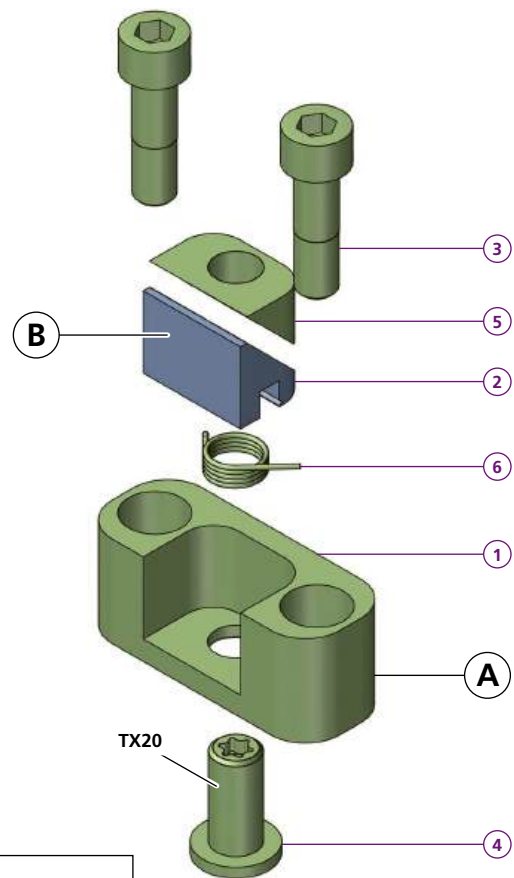
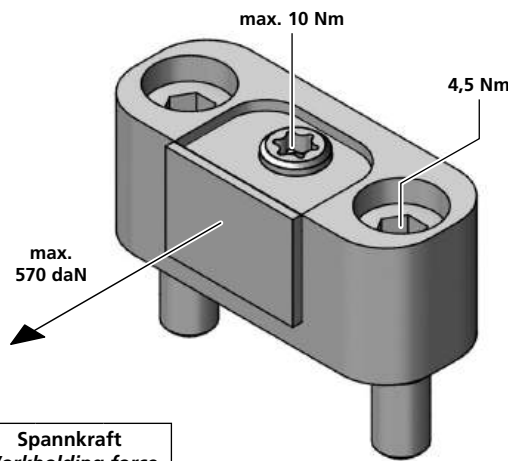
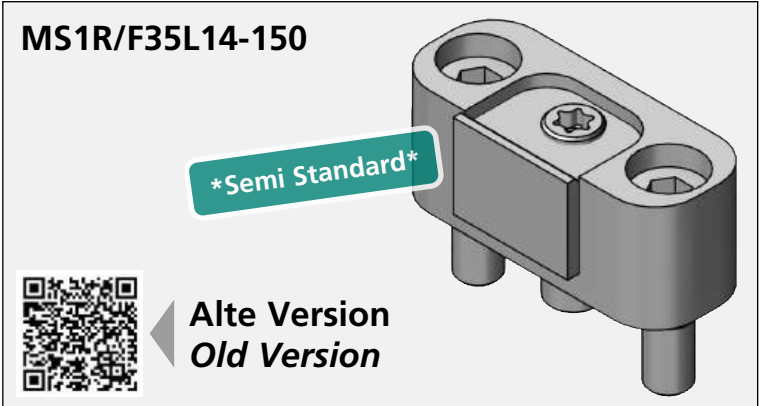
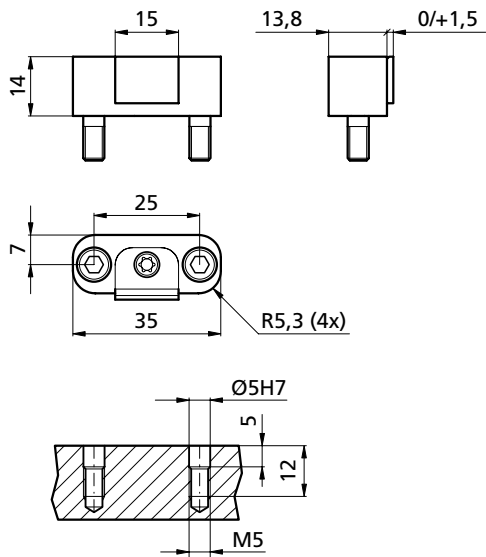

Drehmoment Torque		Spannkraft Workholding force		
Nm	(lb-ft)	~daN	~(lb)	~t
7	5,18	= 390	860	0,39
8	5,92	= 450	990	0,45
9	6,66	= 510	1120	0,51
10	7,4	= 570	1250	0,57

**Achtung:** Bei Spannkraften über 400 daN (0,4t) muss das Spannmodul in eine Nut eingelassen werden (Nuttiefe mindestens 1mm)

**Remark:** Using forces higher than 400 daN, clamps must be mounted into a slot (depth minimum 1mm)

Nuttiefe 1mm / Depth 1mm

Vorrichtungplatte / Fixture plate

- MS1F35L14-152**
- 1x TK181266
- MS1R35L14-152**
- 1x TF190596
- 1x \_\_\_\_\_
- 2x MS50
- 1x GEWST6L14
- 1x MSK15W45
- 1x SFED6W90
- kg ~0,03

Bestellbeispiel / Ordering example: 1x MS1F35L14-152 & 1x B151

	B150	B151
C	15	15
H	11	11
L	40,3	40,3
e	40	40
i	HV700	HV700
	x0,2mm	x0,2mm
kg	~0,004	~0,004

Separat bestellen / Order separately

VS1R26L35-31

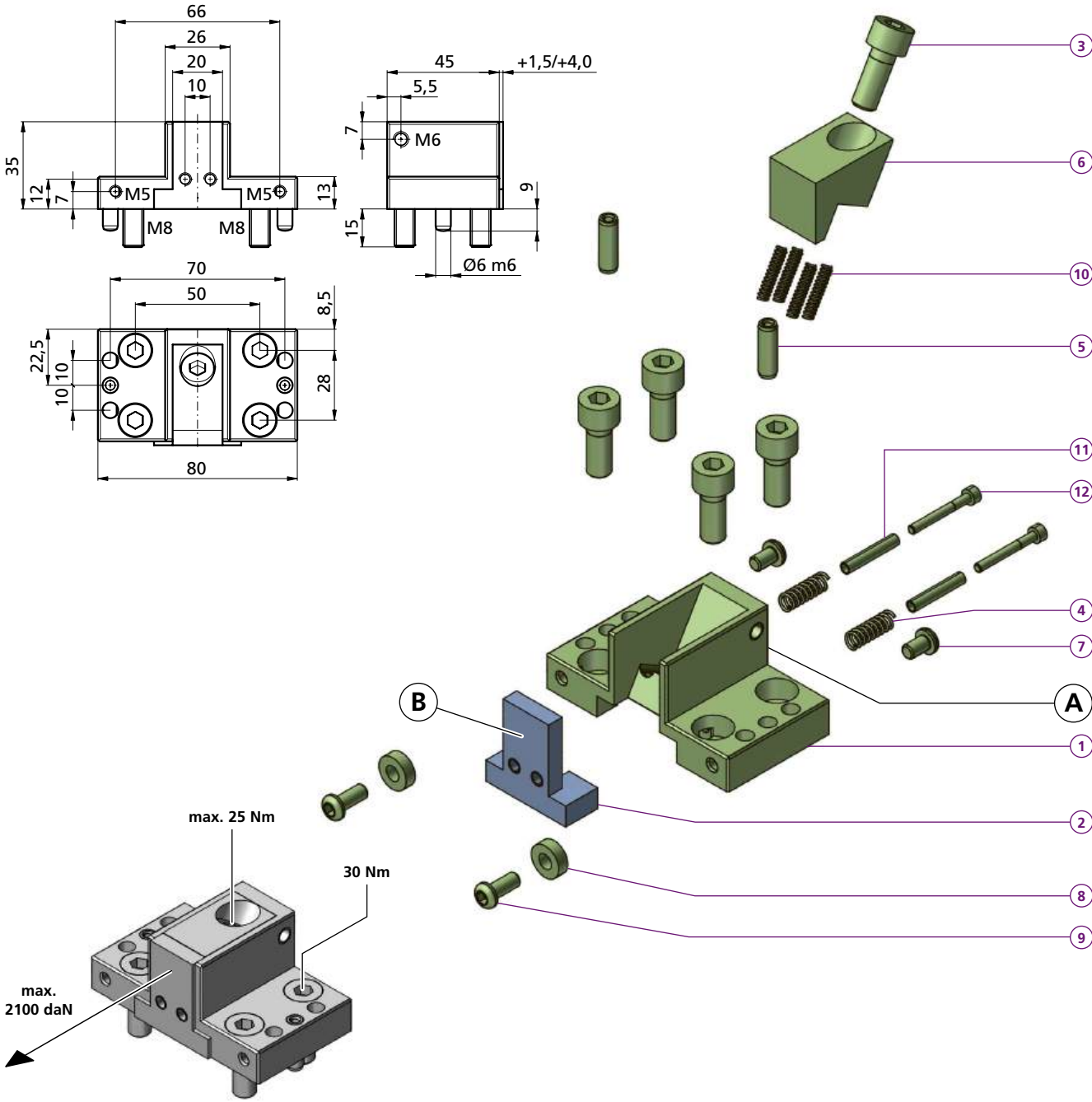

VS1R26L35-31	
1	1x TF140724
2	1x
3	5x M8X20ISO4762
4	2x FED0618
5	2x CCBO0802
6	1x B30
7	2x M5X8ISO7380
8	2x CCD004
9	2x M5X12ISO7380
10	4x FED0418
11	2x CCD422
12	2x M3X25ISO4762
kg	~0,55

Bestellbeispiel / Ordering example: 1x VS1R26L35-31 & 1x B32

	B31	B32	B33
C	20	20	20
H	35	35	35
L	6	6	6
D	-	-	-
e	-	-	-
i	HV700 x0,2mm	HV700 x0,2mm	*
kg	~0,046	~0,046	~0,046

\* = weicher Stahl / soft steel

Separat bestellen / Order separately

### VS1R/F41L30-51

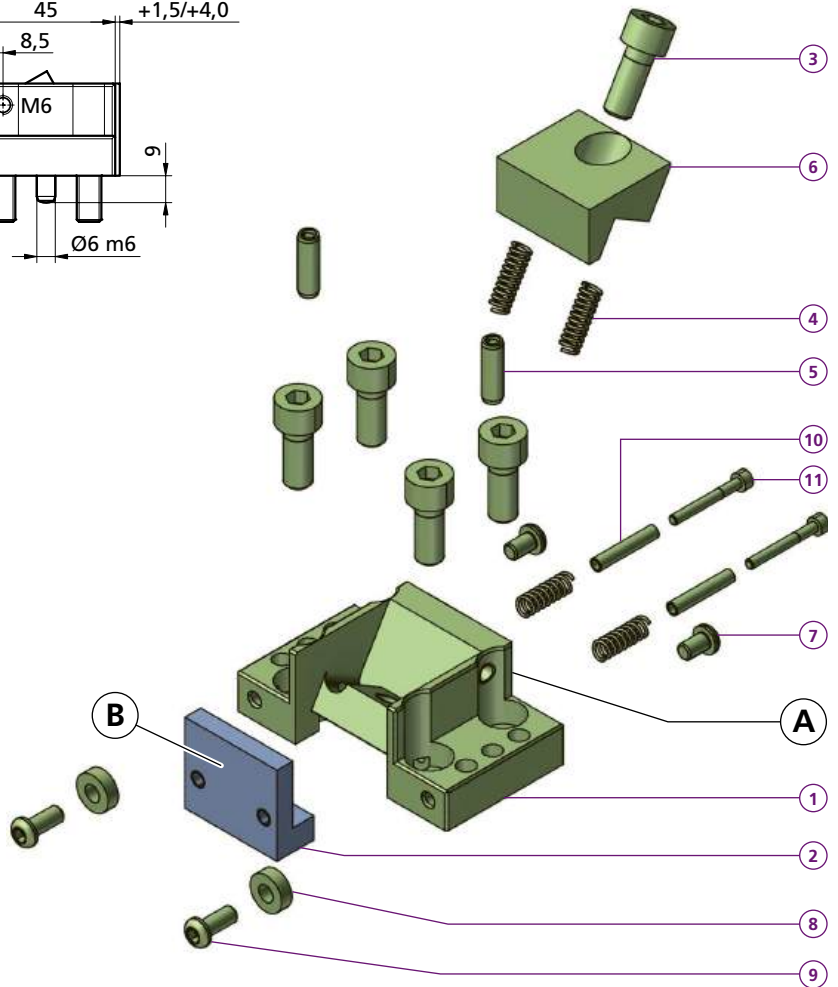
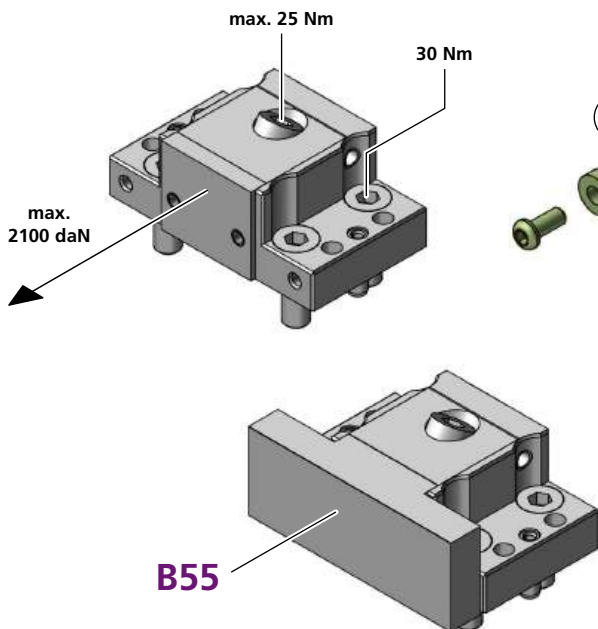
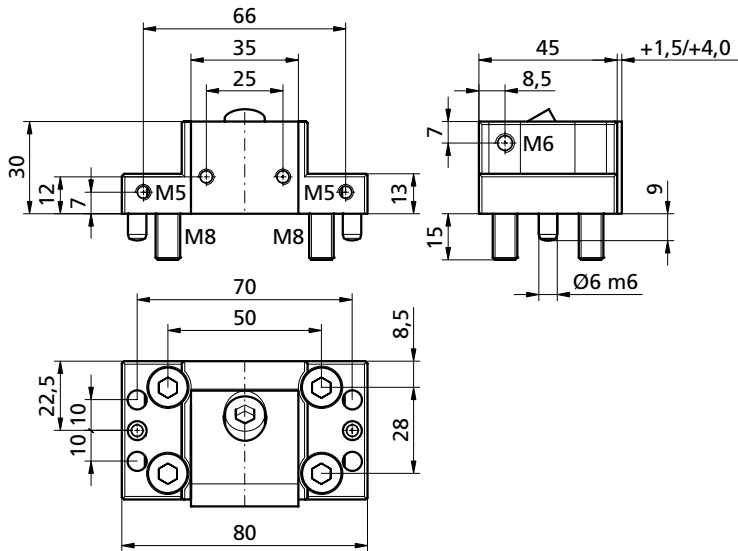

<b>VS1F41L30-51</b>	<b>A</b>
1x TF140727	
<b>VS1R41L30-51</b>	
1x TF140728	
1x	
5x M8X20ISO4762	
4x FED0618	
2x CCBO0802	
1x B78	
2x M5X8ISO7380	
2x CCD004	
2x M5X12ISO7380	
2x CCD422	
2x M3X25ISO4762	
kg ~0,545	

**B** Bestellbeispiel / Ordering example: 1x VS1R41L30-51 & 1x B52

	B51	B52	B53	B54	B55
<b>C</b>	35	35	35	35	80
<b>H</b>	30	30	30	35	30
<b>L</b>	6	6	10	10	11,5
<b>D</b>	-	-	-	-	-
<b>e</b>	-	-	-	-	-
<b>i</b>	HV700 x0,2mm	HV700 x0,2mm	*	*	*
<b>kg</b>	~0,06	~0,06	~0,06	~0,12	~0,27

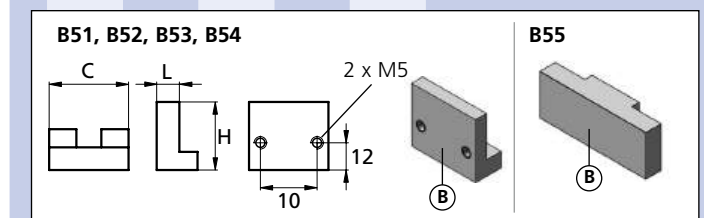

**Vorrichtungsbau-Modul für Linearbacken**

Alle bestehenden Linearbacken passen auf dieses Modul  
(**powerCLAMP** Seite **84 - 85**). In die Vorrichtungsplatte wird eine Tasche gefräst um das Modul zu positionieren. Gut geeignet sind die Anschlagbacken **MAND** und **MANF** um als Gegenbacke zu dienen.

**Fixture clamp module for linear jaws**

All of our standard linear jaws fit to this clamp module  
(**powerCLAMP** Page **84 - 85**). All to do is milling a pocket to fit and positioning the clamp modules. To use the **MAND** and **MANF** as datum stop will make a perfect match. (Seite / Page **175 - 176**)

**Fertigungsmasse für die Vorrichtungsplatte**  
**Machining data for the fixture plate**

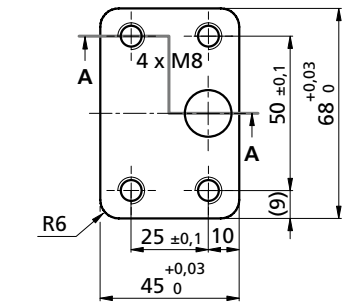

**Schnitt / Section A-A**

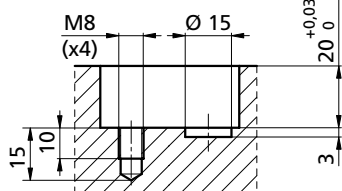

Das Fertigungsmass gilt auch für das Anschlagmodul.  
The production dimension is also valid for the end module. (VA168-20PRG)

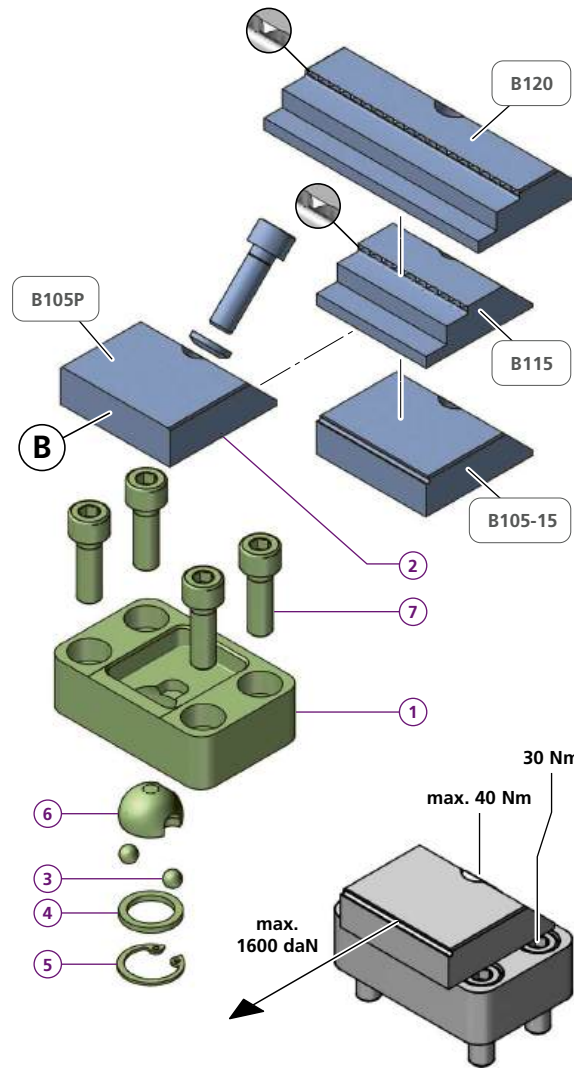
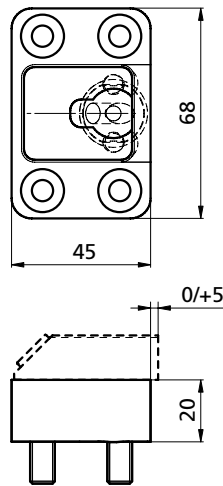

VS1X68L20-105	
1	1x TB150170
2	1x <b>powerCLAMP</b> p 84 - 85
3	1x BN869d=6
4	1x TN100747
5	1x TN100779
6	1x PCKMR45M8
7	4x M8X20ISO4762
kg	~0,42

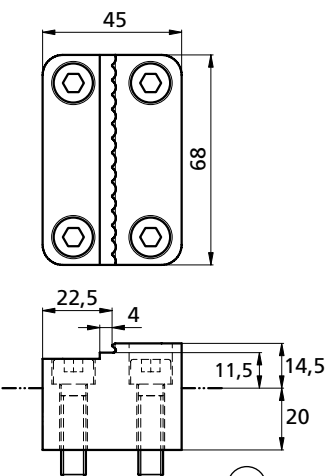

VA168-20PRG	
8	1x TH160280
9	4x M8X30ISO4762
kg	~0,75

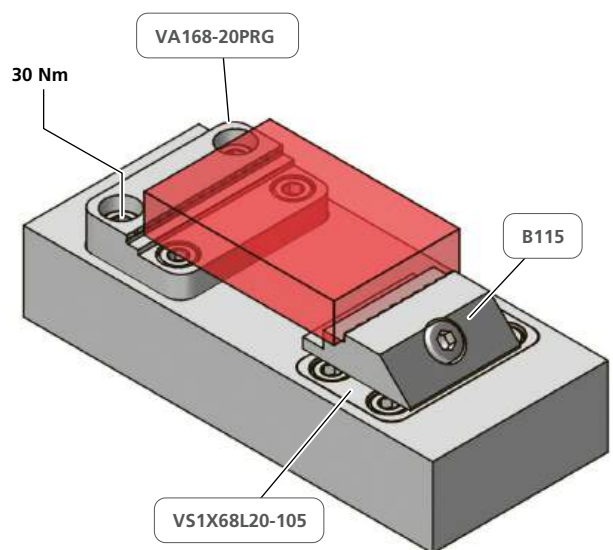
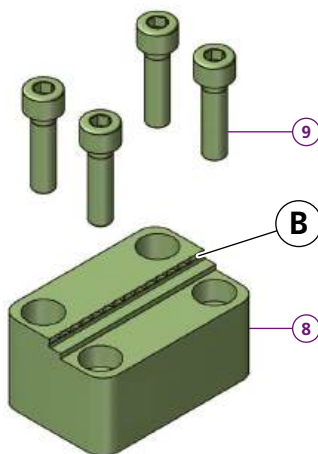

Bestellbeispiel / Ordering example: 1x VS1X68L20-105 & 1x B105P

Separat bestellen / Order separately

**VS1F48L50-105**  
**VS1P48L50-105**

**Linear**  
**microCLAMP**

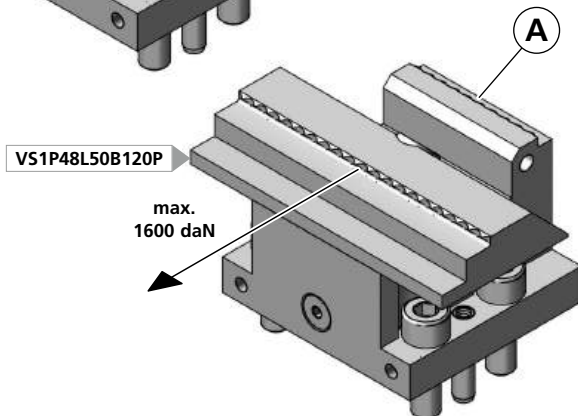
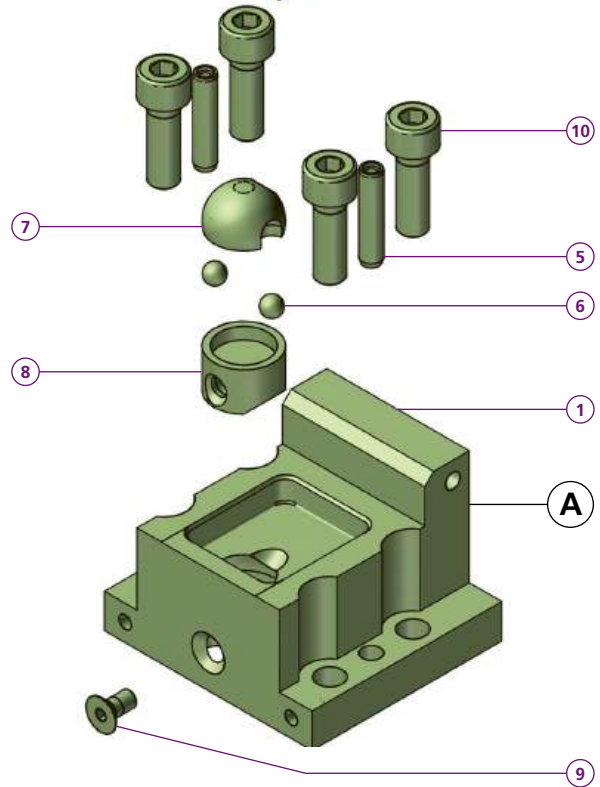
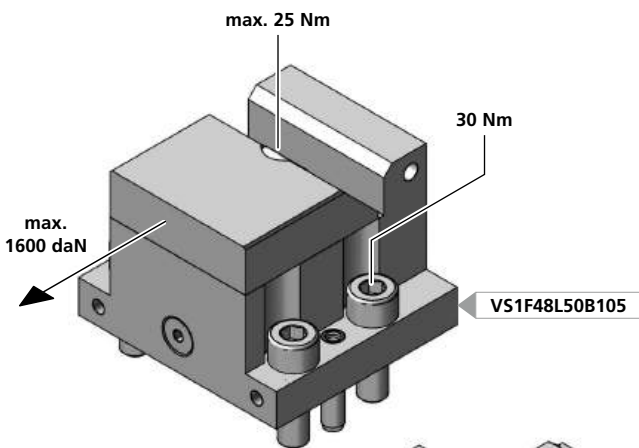
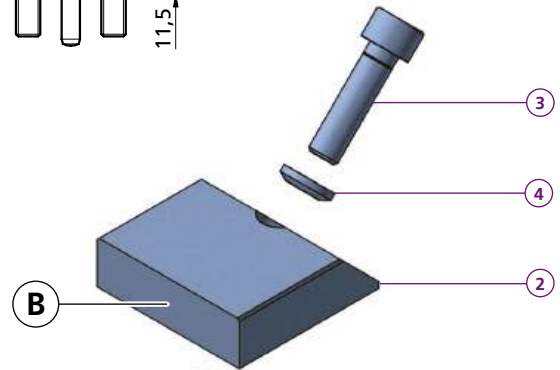
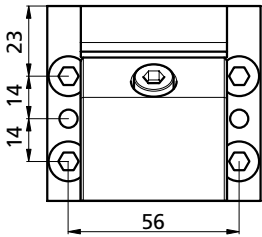
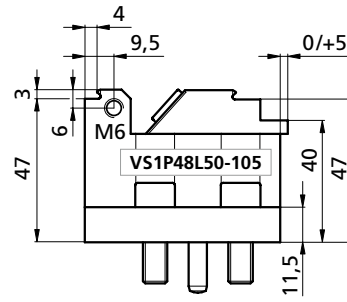
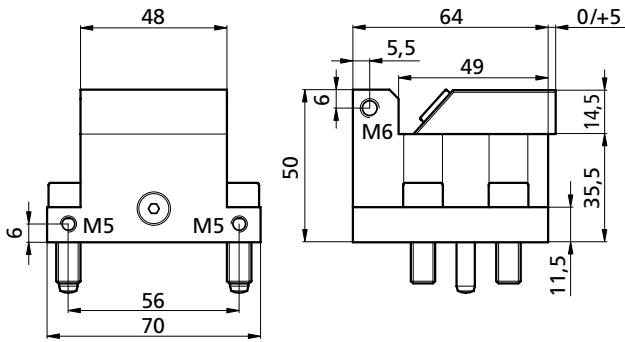

	<b>A</b>	
	<b>VS1F48L50-105</b>	
1	1x TK120807	
	<b>VS1P48L50-105</b>	
1	1x TK120761	
2	1x <b>powerCLAMP</b> p. 84 - 85	
3	1x M8X30ISO4762	
4	1x PCUSR14	
5	1x 6-m6x26 DIN 79790	
6	2x BN869d=6	
7	1x PCKMR45M8	
8	1x TS120001-04	
9	1x M5X10DIN7991	
10	4x M8X25ISO4762	
kg	~1,21	

Bestellbeispiel / Ordering example: 1x VS1F48L50-105 & 1x B105

Separat bestellen / Order separately

VS1R/F80L30-51

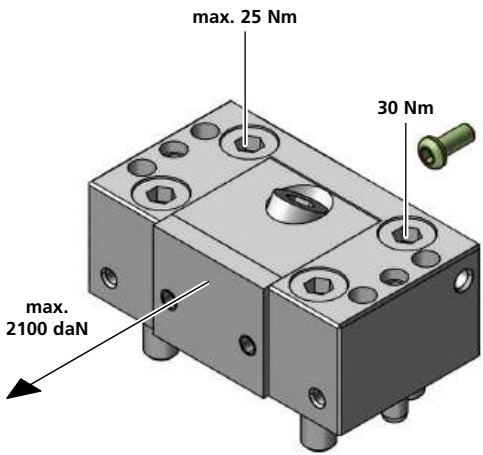
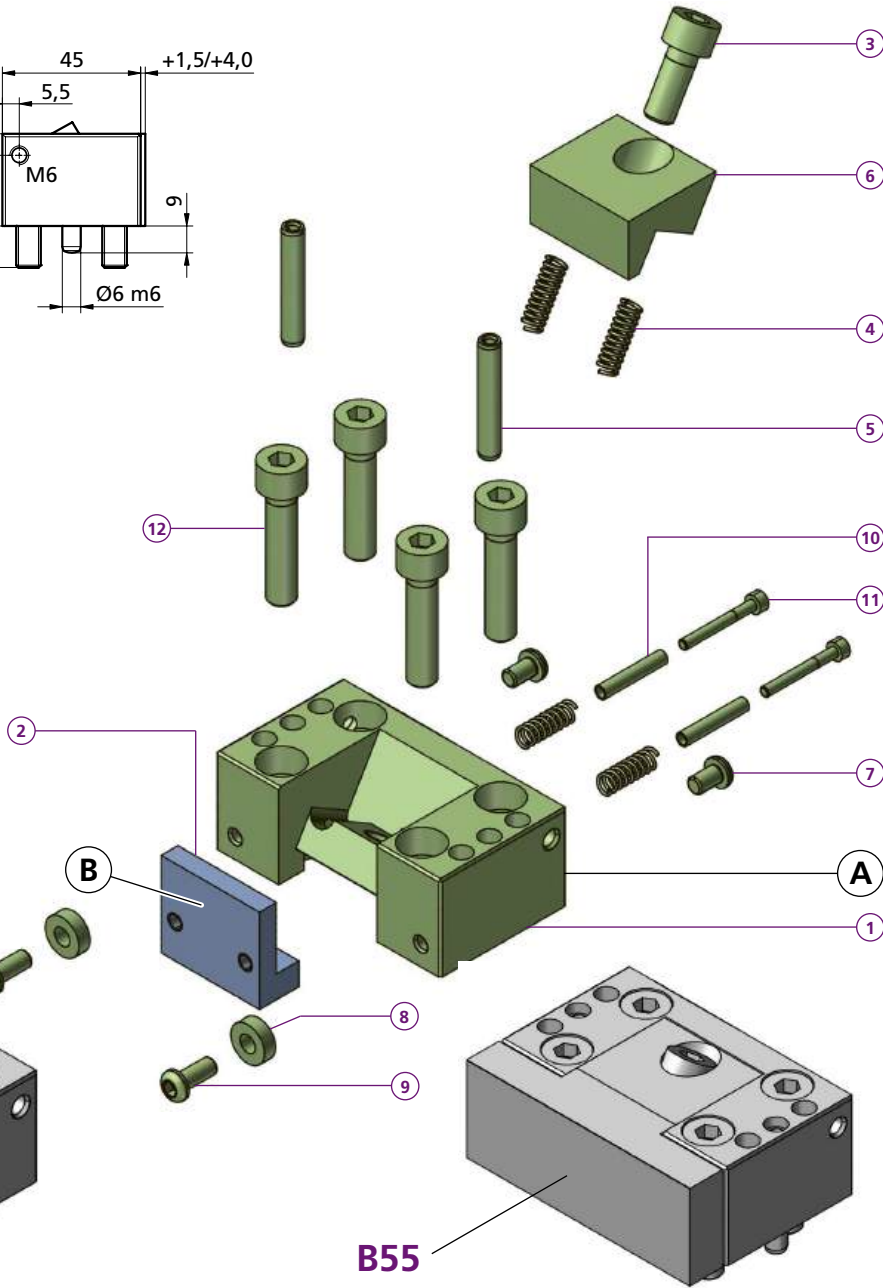
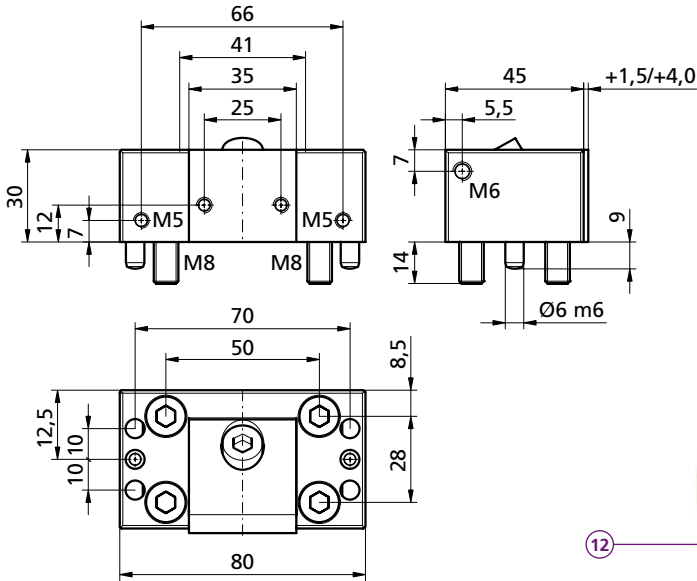

<b>VS1F80L30-51</b>	
1	1x TF140731
<b>VS1R80L30-51</b>	
1	1x TF140732
2	1x
3	1x M8X20ISO4762
4	4x FED0618
5	2x CCBO0801
6	1x B78
7	2x M5X8ISO7380
8	2x CCD004
9	2x M5X12ISO7380
10	2x CCD422
11	2x M3X25ISO4762
12	4x M8X35ISO4762
kg	~0,74

Bestellbeispiel / Ordering example: 1x VS1R80L30-51 & 1x B52

	B51	B52	B53	B54	B55
C	35	35	35	35	80
H	30	30	30	35	30
L	6	6	10	10	11,5
D	-	-	-	-	-
e	-	-	-	-	-
i	HV700	HV700	*	*	*
	x0,2mm	x0,2mm			
kg	~0,06	~0,06	~0,06	~0,12	~0,27

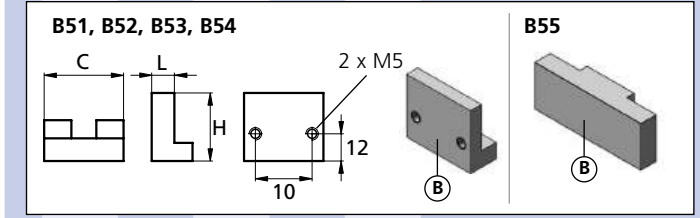

\* = weicher Stahl / soft steel

Separat bestellen / Order separately

### VS1X59L60K

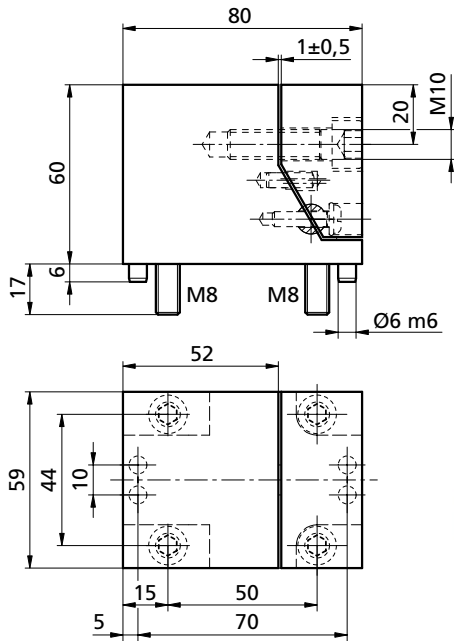

Empfohlener Sechskantschlüssel  
Recommended hexagon wrench  
**PB2212L/6**

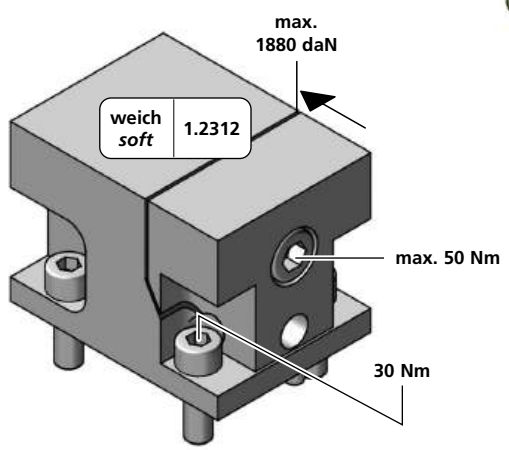
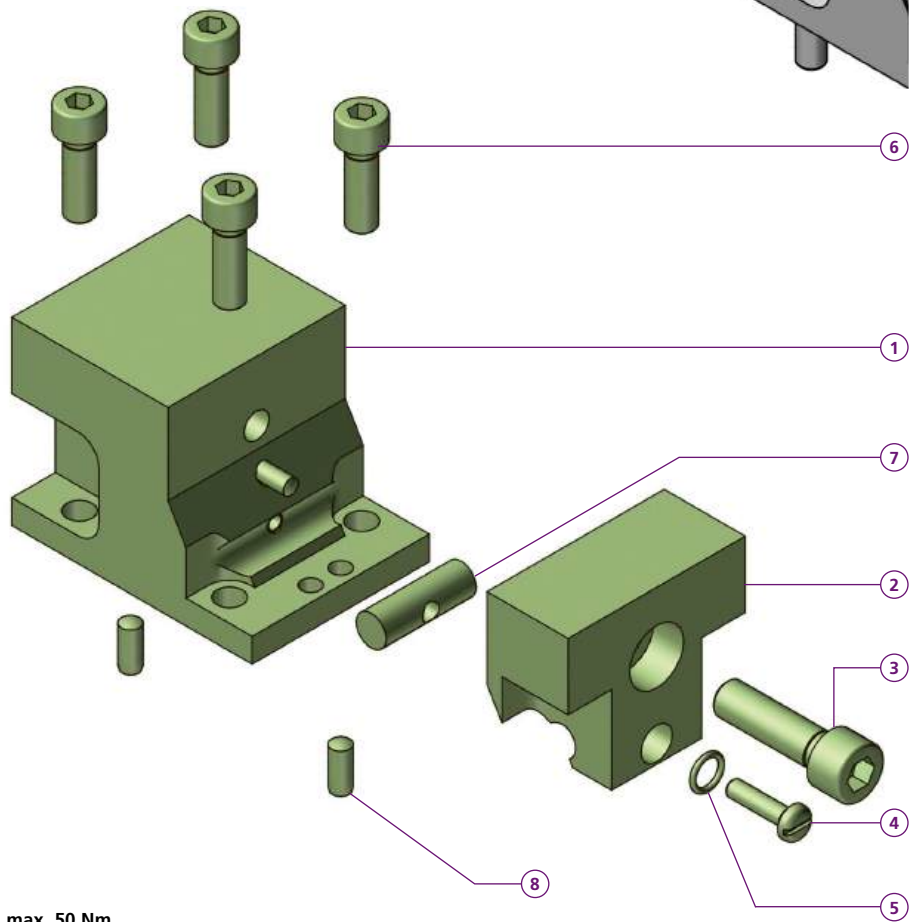
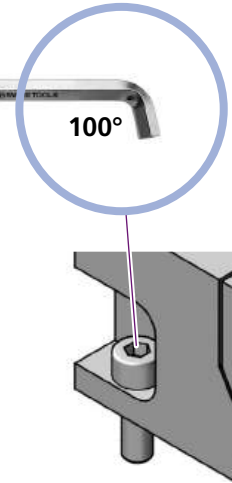

Spannstelle an Werkstück  
angepasst und nitriert.  
Clamping face machined to  
the shape of the workpiece  
and nitrided.

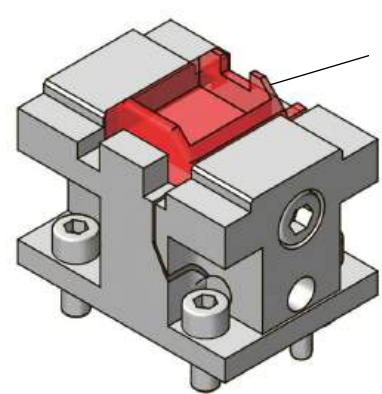

*VS1X59L60K	
1	1x VS1X59L60H5KA
2	1x VS1X59L60H5KS
3	1x M10X35ISO4762
4	1x M5X20DIN85A
5	1x ORØ8x1,5
6	4x <b>M8X25ISO4762</b>
7	1x VS1X59L60H5KG
8	2x 6m6x14 DIN 6325
kg	~1,89

### VS1X59L60H5

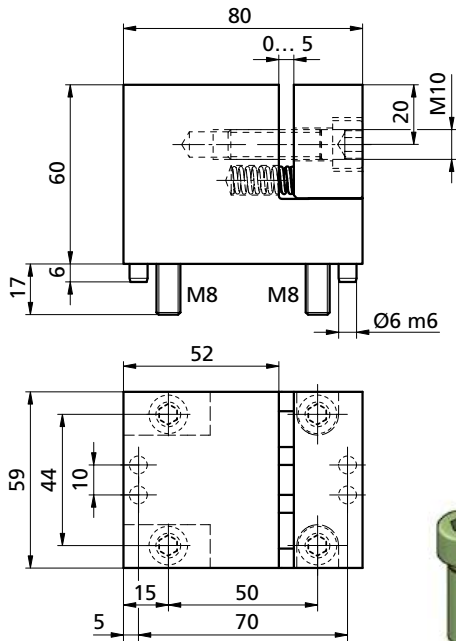

Empfohlener Sechskantschlüssel  
Recommended hexagon wrench  
**PB2212L/6**

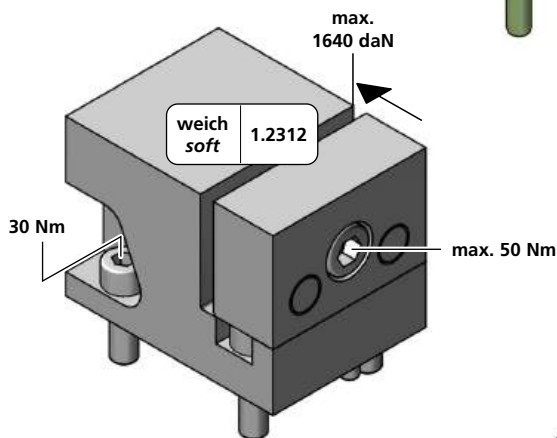
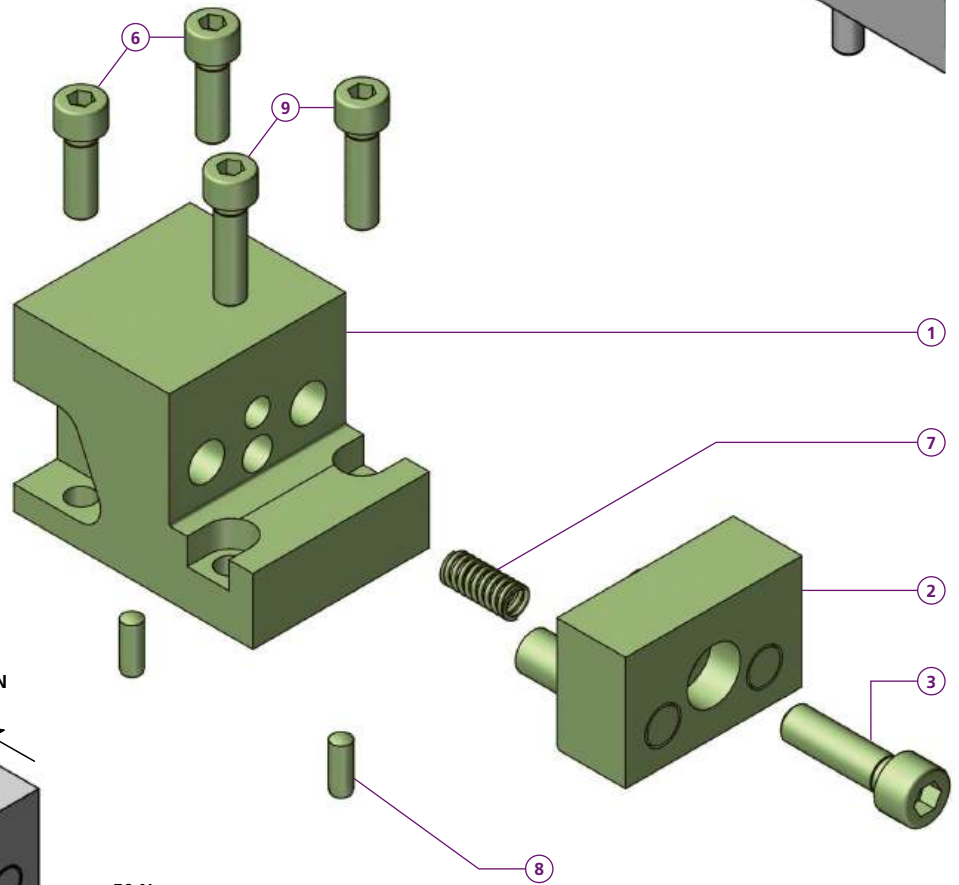
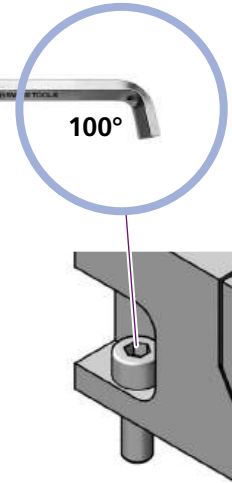

Anwendungsbeispiele  
Sample applications

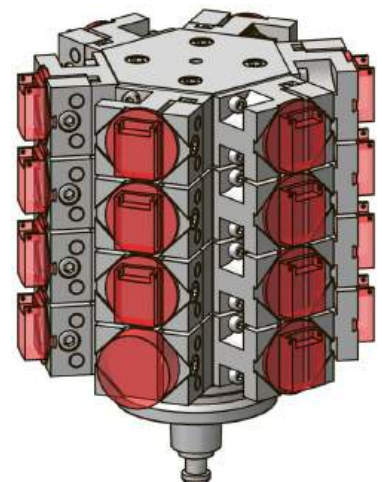
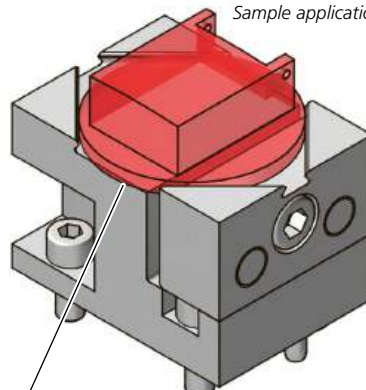

Spannstelle an Werkstück angepasst und nitriert.  
Clamping face machined to the shape of the workpiece and nitrided.

*VS1X59L60H5	
1	1x VS1X59L60H5A
2	1x VS1X59L60H5S
3	1x M10X35ISO4762
6	2x <b>M8X25ISO4762</b>
7	1x FED0833
8	2x 6m6x14 DIN 6325
9	2x <b>M8X30ISO4762</b>
kg	~1,94

\* = Stahl / steel 1.2312

Bestellbeispiel / Ordering example : **VS1X59L60H5**

Separat bestellen / Order separately

durchgehärtet / through hardened										nitriert / nitrated									
<b>26mm</b>	<b>B</b>	<b>H</b>	<b>N</b>	<b>kg</b>	<b>41mm</b>	<b>B</b>	<b>H</b>	<b>N</b>	<b>kg</b>	<b>23mm</b>	<b>B</b>	<b>H</b>	<b>N</b>	<b>kg</b>	<b>41mm</b>	<b>B</b>	<b>H</b>	<b>N</b>	<b>kg</b>
CCU15026	26	15	2,2	~0,017	CCU15081	41	15	2,2	~0,018	MCU11037	23	11	2	~0,004	CCU15083	41	15	3	~0,025
CCU20026	26	20	2,2	~0,02	CCU20081	41	20	2,2	~0,022	MCU15037	23	15	2	~0,006	CCU20083	41	20	3	~0,029
CCU25026	26	25	2,2	~0,022	CCU25081	41	25	2,2	~0,025	MCU18037	23	18	2	~0,008	CCU25083	41	25	3	~0,034
CCU30026	26	30	2,2	~0,025	CCU27581	41	27	2,2	~0,027	MCU20037	23	20	2	~0,008	CCU27583	41	27,5	3	~0,036
CCU32526	26	32,5	2,2	~0,026	CCU30081	41	30	2,2	~0,029	MCU22537	23	22,5	2	~0,008					
<b>38mm</b>	<b>B</b>	<b>H</b>	<b>N</b>	<b>kg</b>	<b>80mm</b>	<b>B</b>	<b>H</b>	<b>N</b>	<b>kg</b>	<b>26mm</b>	<b>B</b>	<b>H</b>	<b>N</b>	<b>kg</b>	<b>80mm</b>	<b>B</b>	<b>H</b>	<b>N</b>	<b>kg</b>
CCU30039	38	30	2,2	~0,028	CCU15080	79	15	2,2	~0,019	CCU15027	26	15	3	~0,024	CCU15082	79	15	3	~0,026
CCU35039	38	35	2,2	~0,031	CCU20080	79	20	2,2	~0,027	CCU20027	26	20	3	~0,027	CCU20082	79	20	3	~0,036
CCU40039	38	40	2,2	~0,035	CCU25080	79	25	2,2	~0,035	CCU25027	26	25	3	~0,03	CCU25082	79	25	3	~0,045
CCU45039	38	45	2,2	~0,039	CCU27580	79	27,5	2,2	~0,039	CCU30027	26	30	3	~0,033	CCU27582	79	27,5	3	~0,049
					CCU30080	79	30	2,2	~0,043	CCU32527	26	32,5	3	~0,034					
					CCU35080	79	35	2,2	~0,05										
					CCU40080	79	40	2,2	~0,057										
					CCU45080	79	45	2,2	~0,063										

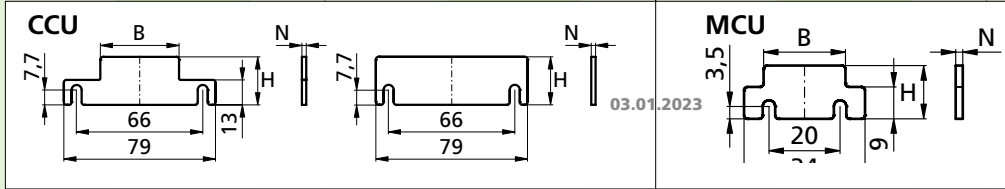

**Schraubenzieher mit Konterung** für  
**Screwdriver with holding sleeve** for



CCBXSK

**Positionsbolzen**  
**Position pin**

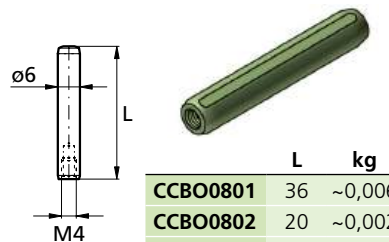

**Bolzen-Auszieher**  
**Pin puller**



CCAZ1050

**Positionierstift** (spreizbar)  
**Locating pin** (expandable)

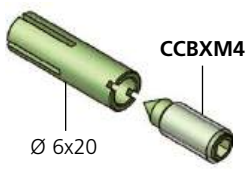

CCBX0802

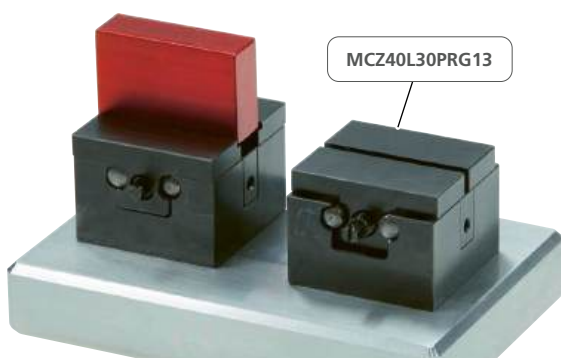

Mehr Informationen siehe Zentrischspanner  
For more information check the self centring vise

p. 116



Mehr Informationen siehe Zentrischspanner  
For more information check the self centring vise

p. 127

**Universalbacke / Universal jaw**

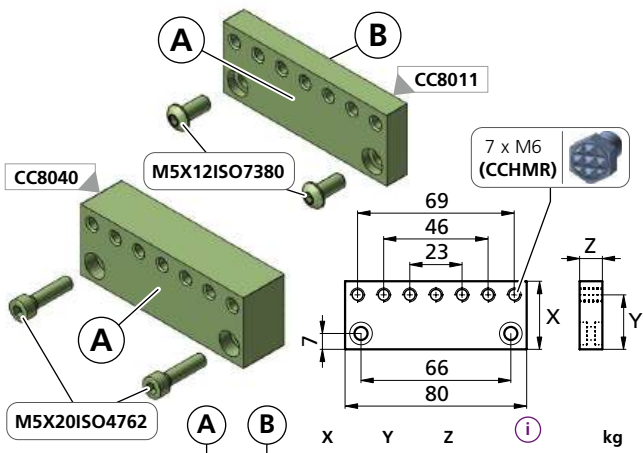

CC8011	CC8025	CC8040
X	Y	Z
30	44	20
24	44	20
10	10	*
56 HRC	56 HRC	*
~ 0,15	~ 0,28	~ 0,33

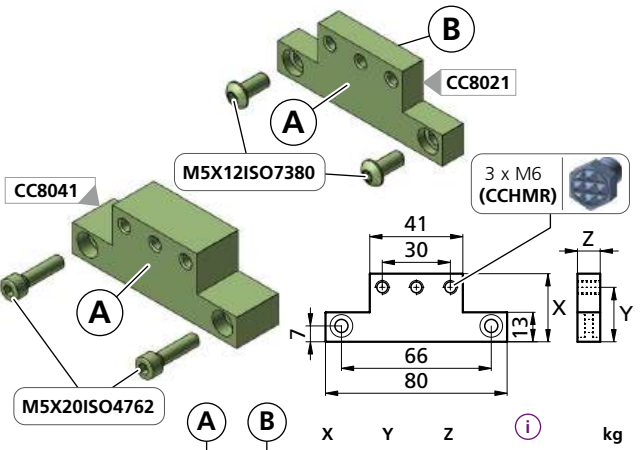

CC8021	CC8026	CC8041
X	Y	Z
30	44	20
24	44	20
10	10	*
56 HRC	56 HRC	*
~ 0,11	~ 0,17	~ 0,24

**Prismabacke / Prismatic jaw**

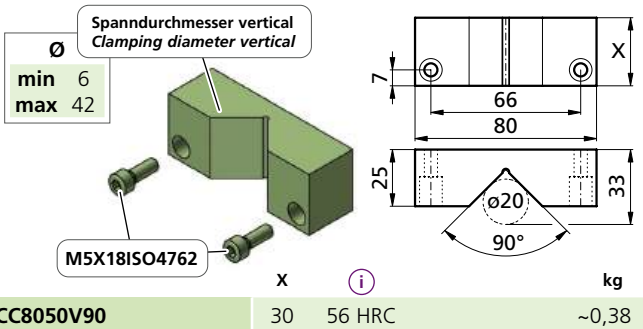

CC8050V90	X	56 HRC	kg
30	56 HRC	~0,38	

**Weiche Backe / Soft jaw**

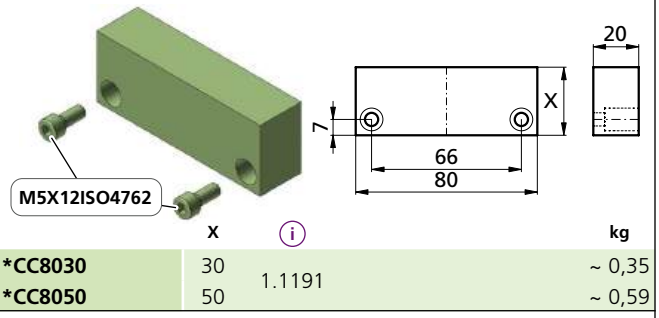

*CC8030	X	1.1191	kg
*CC8050	50	1.1191	~ 0,35
			~ 0,59

**Backe mit 2 Pendeldruckstücken / Jaw with 2 swivelling balls**

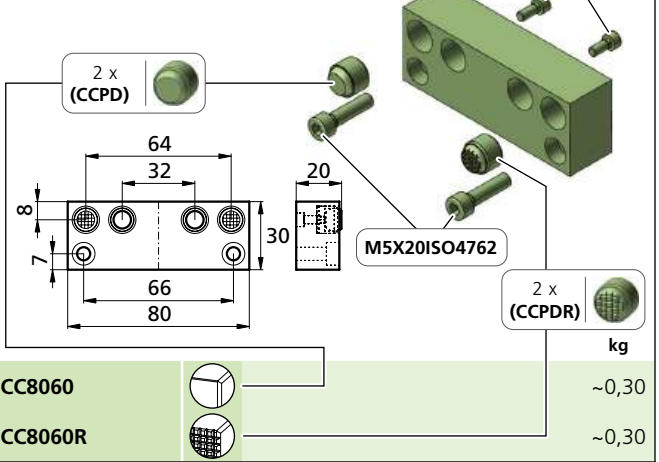

CC8060	CC8060R
~0,30	~0,30

**Backe für Druckstift / Jaw for pressure pin**

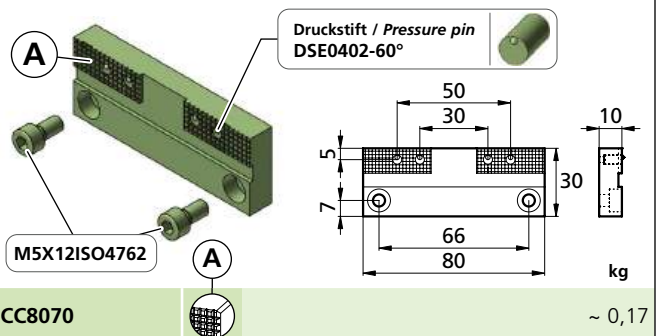

CC8070	kg
~ 0,17	~ 0,17

**Backe / Jaw**

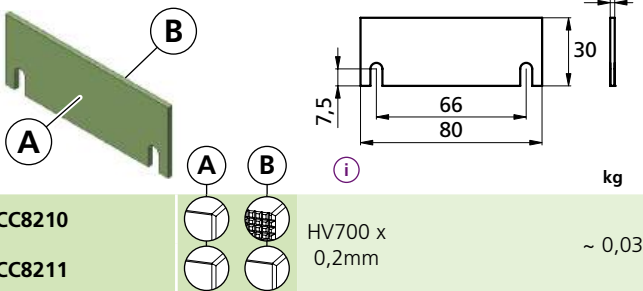

CC8210	CC8211
HV700 x 0,2mm	HV700 x 0,2mm
~ 0,03	~ 0,02

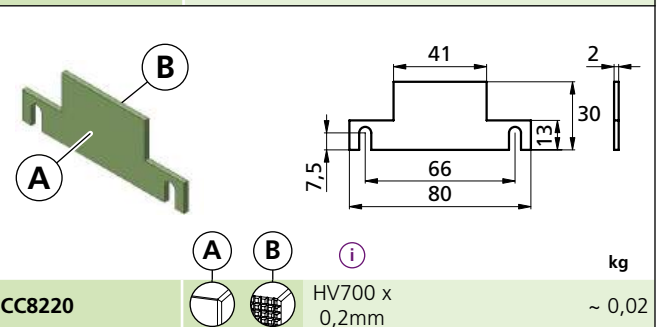

CC8220	kg
~ 0,02	~ 0,02

\* = weicher Stahl / soft steel

Bestellbeispiel / Ordering example: CC8011

# Mechanischer Bohrungsspanner Mechanical hole clamping

microCLAMP

Bohrungsgrößen ab  
Bore sizes from  $\varnothing 6$  mm

Art. Nr.	$\varnothing$ max. Aufweitung Widening	QR-Code
VB1-21-XXXX	0,5	
VB1-22-XXXX		
VB1-23-XXXX		
VB1-24-XXXX		
VB1-41-XXXX	0,5	
VB1-42-XXXX		
VB1-43-XXXX		
VB1-44-XXXX		
VB1-44-XXXX		

Bestellbeispiel / Order example:  
Bohrung Werkstück =  $\varnothing 15,7$  mm  
XXXX = 1570

Artikelnummer	VB1-41-1570
Article number	VB1-42-1570
Artikelnummer	VB1-43-1570
Article number	VB1-44-1570

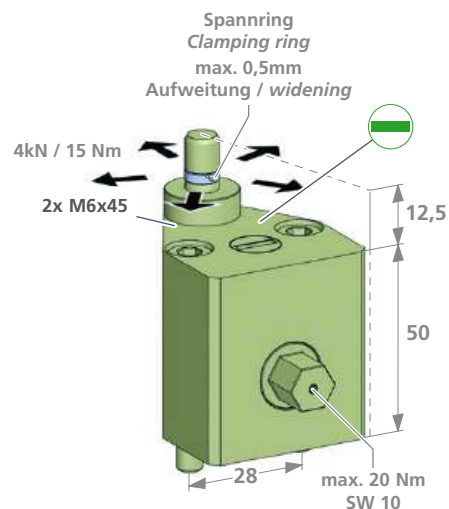

Spannringe werden für den gewünschten Spanndurchmesser geliefert.  
Clamping rings are supplied for the required clamping diameter.

- ✓ 2 Baugrößen  
2 sizes
- ✓ Bohrungsgrößen ab  $\varnothing 6 - 30$  mm  
bore sizes from
- ✓ Wiederholgenauigkeit  $< 0,02$  mm  
repeat accuracy
- ✓ selbsthemmende Spannschraube  
self-locking clamping spiral
- ✓ gute Werkstück Zugänglichkeit  
good workpiece accessibility
- ✓ einfache Anpassung an verschiedene Spanndurchmesser  
simple adaptation to different clamping diameters
- ✓ kombinierbar mit powerCLAMP  
can be combined with powerCLAMP

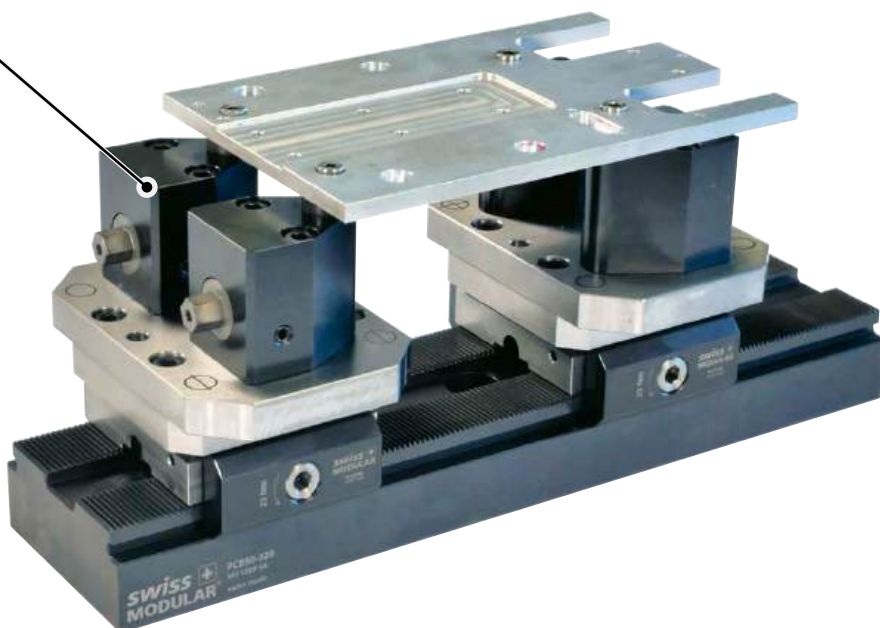
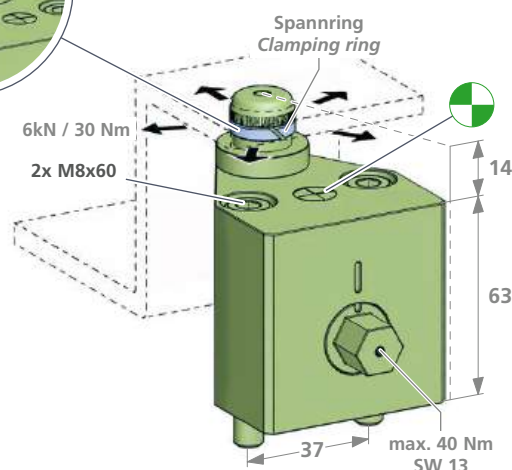
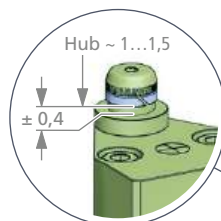

mit Nullpunkt  
with zero point

mit Ausgleich  
with equalisation

ohne Nullpunkt  
without zero point

ohne Nullpunkt / Niederzug  
without zero point / pull down



# *apto*CLAMP & *5axes*

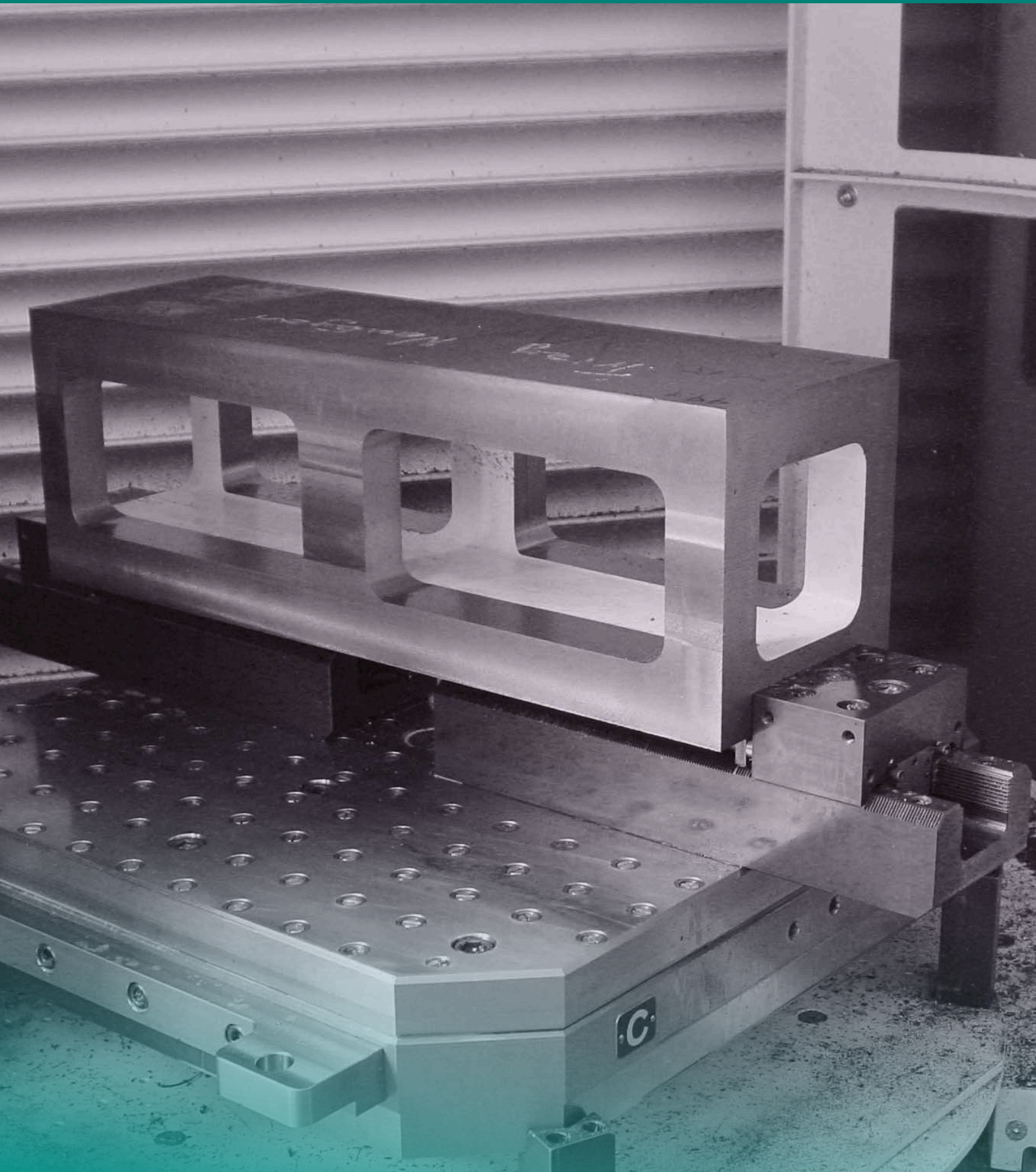



Einleitung | *Introduction* ..... 209 - 212



Bedienungsanleitung | *Operating manual* ..... 213 - 214

Anwendungsbeispiele | *Examples of application* ..... 215 - 220

Basisschiene | *Base-rail* ..... 222

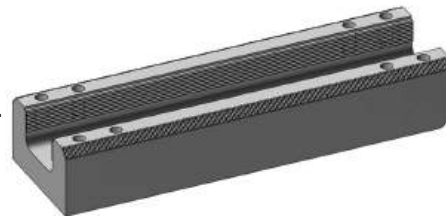

Niederzugspannmodule | *Pull down clamp modules* ..... 223 - 226

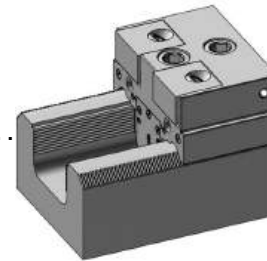

Linearspannmodule mit Präge- und Linearbacken  
*Linear clamping modules with stamping and linear jaws* ..... 227

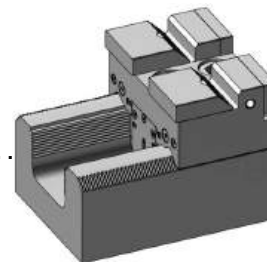

Anschlagmodule | *End module* ..... 228 - 230

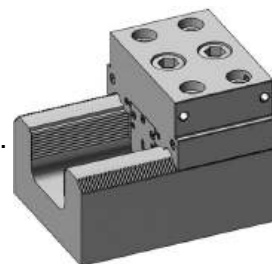

5-Achs Linearanschlagmodule mit Präge- und Linearbacken  
*5-axis linear clamping modules with stamping and linear jaws* ..... 231

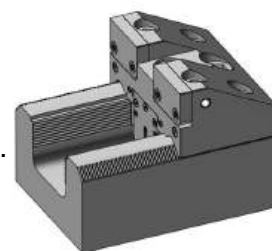

Zubehör | *Accessories* ..... 232 - 233

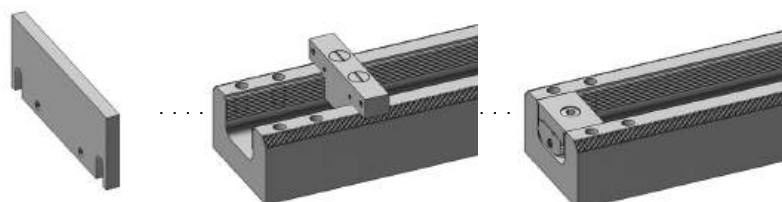

# Die Idee des Mehrfachspannens The idea of multiple workholding

## Schwerstzerspannung / Heavy duty machining

**aptoCLAMP**

Die hohe Spannkraft dieses Systems ermöglicht den Einsatz für schwere Zerspanung.

Mit stabilen Kraftspannern können auf den Basisschienen auch grosse, bis zu mehrere tausend Kilogramm schwere Platten und Blöcke gespannt werden.

*The high clamping force of the Apto Clamp enables heavy cuts. You achieve maximum rigidity with our Apto Clamp modular system! Even if your workpiece is thousands of kilograms you don't have to worry to clamp big parts and big plates.*

## Elefantenstark und anwenderfreundlich Powerful and user-friendly



Zur Positionierung der Spannmodule hat das Apto Clamp neben einer Querverzahnung zusätzlich ein Ankersystem zur Arretierung an einer Längsverzahnung in der Basischiene. Durch die rechtwinklige Verteilung wird eine von Mitbewerbern unerreichte Stabilität gewährleistet. Die Spannmodule liegen auf der genau geschliffenen Auflagefläche der Basis auf. Durch das Ankersystem und die geschliffene Auflagefläche wird das Spannmodul an der Basischiene extrem kraftschlüssig und präzise fixiert. Trotzdem können die Spannmodule völlig ungehindert entlang der Basis verstellt (verschoben) werden. Auch das Auswechseln der Module ist einfach, müssen doch diese nicht aus der Schiene ausgefahren, sondern können abgehoben werden.

*For positioning the clamp modules on the base rails, has the Apto Clamp system next to a positioning serration a horizontal anchor system for locking with enormous force produced by two M16 screws. The end modules have additionally 4 M12 screws to give extra rigidity.*



*The end modules have additionally 4 M12 screws to give extra rigidity.*

## Schnelligkeit / Quickness



1

**Zwei Schraube lösen**  
*Loosen two screws*



2

**Abheben und neu platzieren**  
*Lift and change position*



3

**Zwei Schrauben anziehen**  
*Fasten two screws*

### Vorteile auf einen Blick / Benefits at a glance:

- ➔ Sehr stabil, robuste Bauweise, dadurch hohe Präzision  
*Very stable, robust design allows high precision and heavy machining*
- ➔ Module nach oben abhebbar, kein Ausfahren nötig  
*Modules can be lifted up, no extension needed*
- ➔ Keine verschmutzbaren T-Nuten: Formschlüssig positioniert  
*No chip loading T-slots grooves: Positively positioned*
- ➔ Verzahnung nicht dem Werkstück ausgesetzt  
*The teeth are not exposed to the workpiece*
- ➔ Niederzug- und Linearspannung möglich  
*Pull-down and linear clamping possible*
- ➔ Spannkraft bis 7000 daN pro Modul  
*Clamping force up to 7000 daN per module*

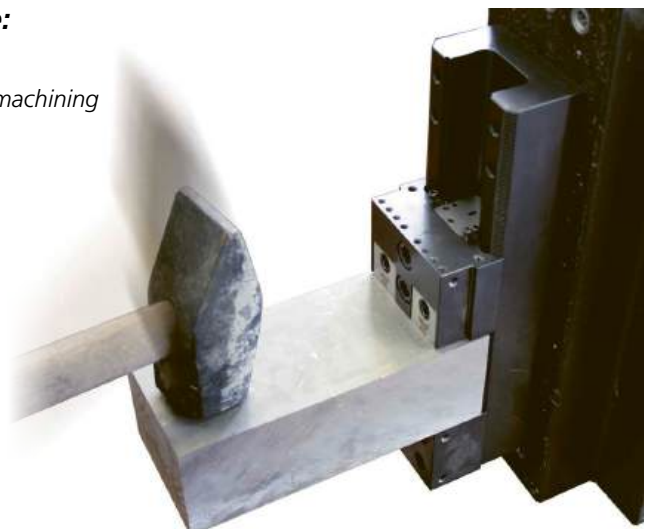

400 mm

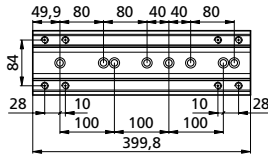

450 mm

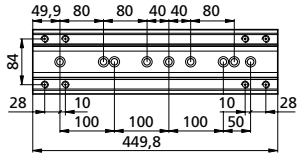

500 mm

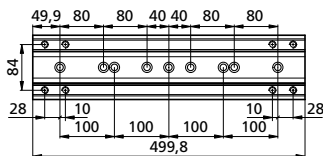

550 mm

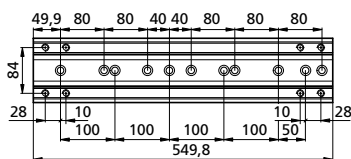

600 mm

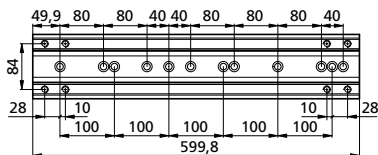

650 mm

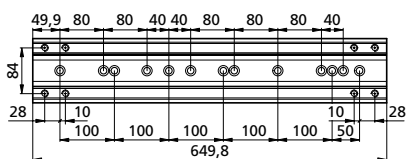

700 mm

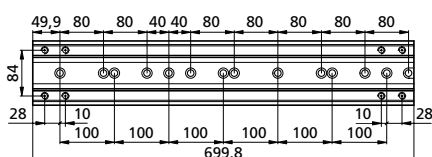

750 mm

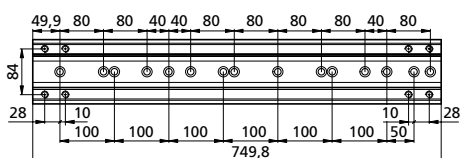

800 mm

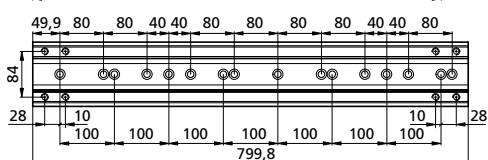

**Basisschiene / Base rail**

Beim Apto Clamp ermöglicht eine Verzahnung mit 2 mm-Teilung auf der Basisschiene ein schnelles und genaues Positionieren der Spann- und Anschlagmodule.

*With the new Apto Clamp a serration of 2mm pitch on the base rail allows a rapid and accurate positioning of the modules.*

Durch gezielte elastische Deformation einer Lippe erfolgt eine spielfreie Paarung. Spann- und Bearbeitungskräfte werden einerseits an der ebenen, robusten Oberseite der Basisschiene aufgenommen, während andererseits das Spannmodul durch einen spreizenden Keil mit robustem Rundgewindeprofil in der Schiene verankert wird.

*The outstanding development is that through elastic deformation of a lip, the engagement between the modules and the base rail is without play. Clamping and machining forces are absorbed on the upper surface of the base rail whereas the vice module is fixed to the rail by an expandable anchor which engages the round serration inside the base rail.*

Das Einfügen zusätzlicher Module zwischen bestehenden Spannstellen ist problemlos möglich. Apto Clamp ist die konsequente Weiterentwicklung vom Power Clamp zur Bearbeitung noch grösserer Werkstücke.

*The insertion of additional vice modules can be accomplished without problems. Apto Clamp is the logical development of Power Clamp to handle even larger work pieces.*

Schnittzeichnung Sectional view of der Basisschiene the base rail

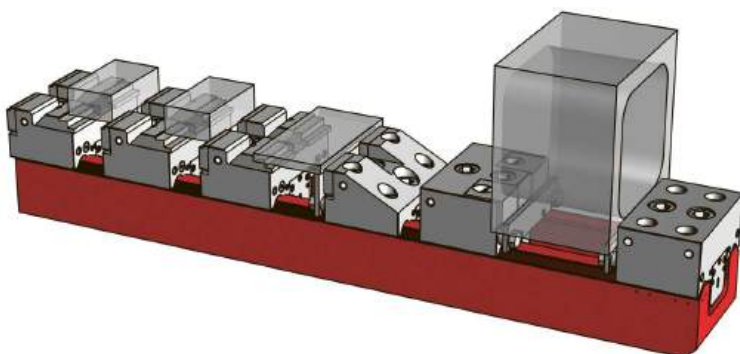
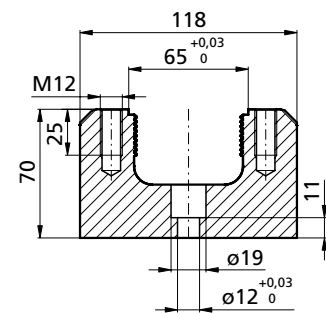

**Das Anschlagmodul / End modules**

In der Regel ist nur ein Anschlagmodul als „feste Backe“ erforderlich.

*In general, only a stop module is required as a „fixed jaw.“*

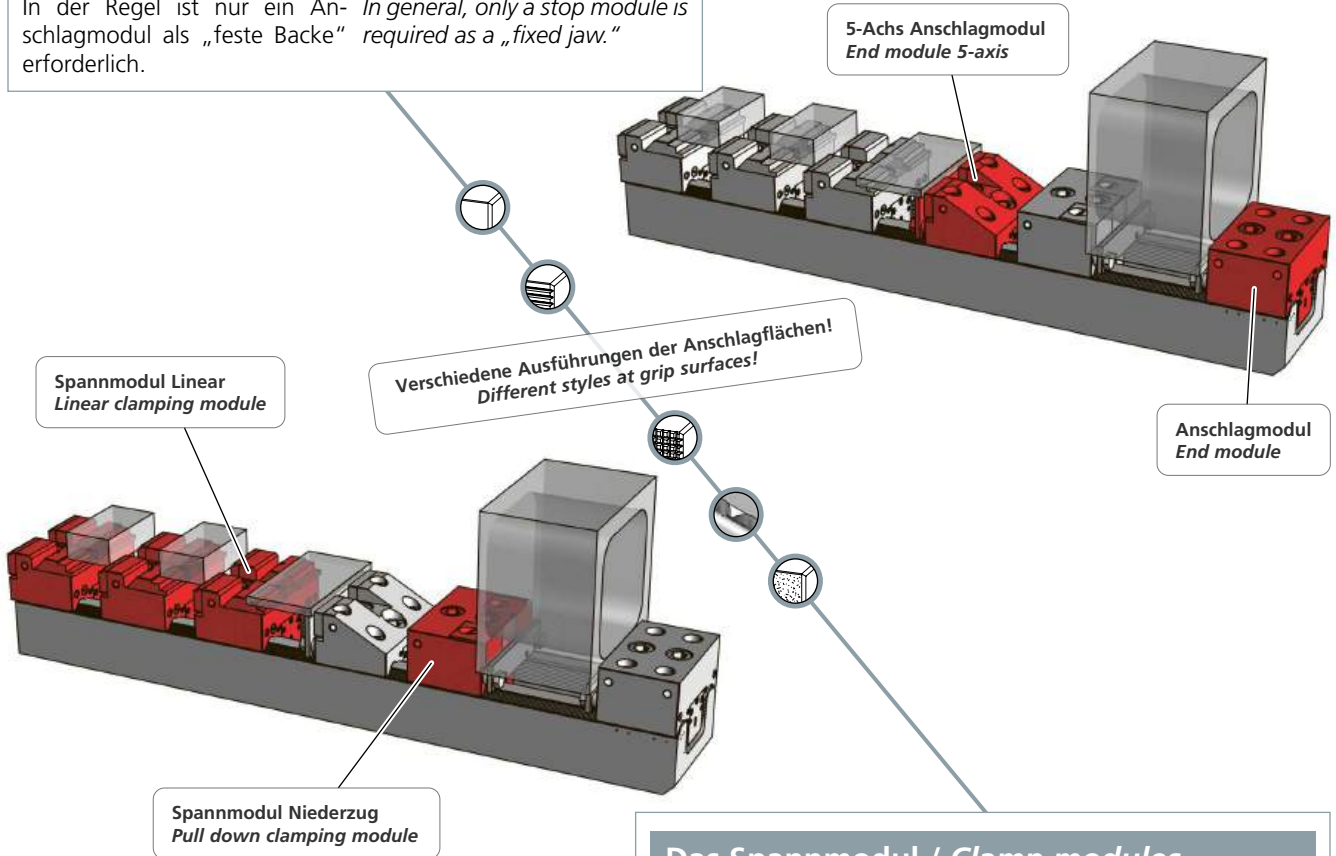

**Das Spannmodul / Clamp modules**

Die «beweglichen Backen» gibt es in zwei Ausführungen. Zum einen für das Niederzugspannsystem und zum anderen für das Linearspannsystem. Dabei dient das Spannmodul bei den Systemen wiederum als Anschlagmodul für die nächste Aufspannung.

*Clampe modules have movable jaws (linear or pull down) in the front to clamp the part and on the back there is the datum face for the next work piece stop. Positioning step on the base rail is 2mm every.*

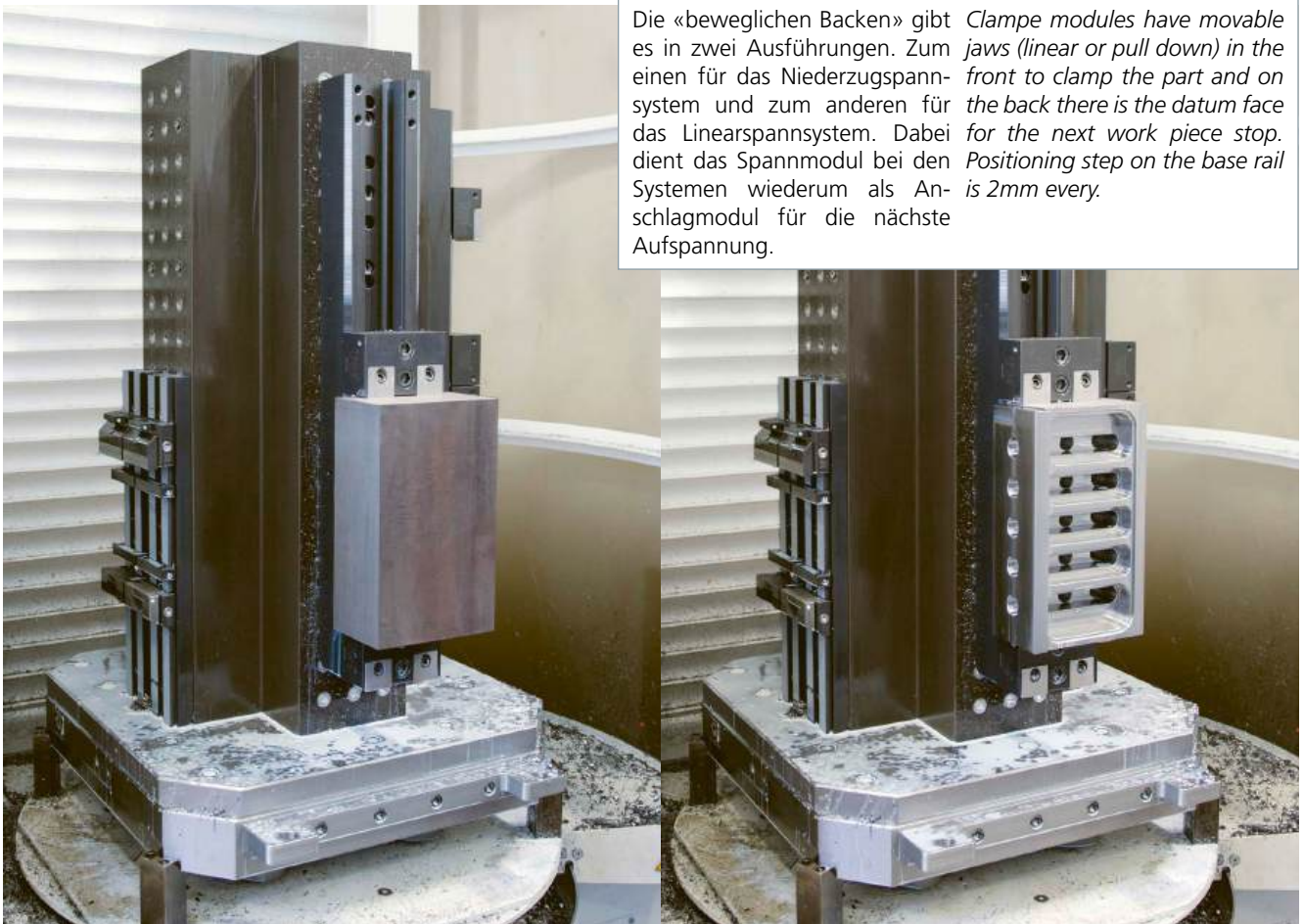

### Niederzugspannmodule Pull down clamp modules

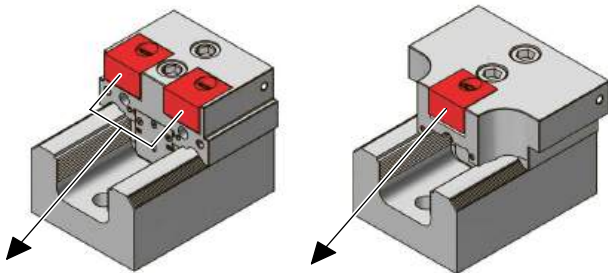

#### Die Fakten beim Niederzugspannsystem

Verstellbereich: 0- 3,8 mm  
Spannkraft: Bis 7'000 daN

#### Vorteile beim Niederzugspannsystem:

- Höhere Haltekräfte
- Hohe Wiederholgenauigkeit
- Optimale Spannmethode für Kleinteile
- Mit Schnellwechselbacken
- Doppelspannsystem in einer Backe zum Spannen und Bearbeiten von zwei Kleinteilen

#### Facts for pull down clamp modules

Jaw range: 0- 3,8 mm  
Clamping force: up to 7'000 daN

#### Advantages pull down jaws:

- Higher holding force
- With linear adaptable jaws
- Also with pull down jaws for the stop side available
- With adapter set can be changed to linear
- Also pull down jaws for datum face

### Linearspannmodule Linear clamp modules

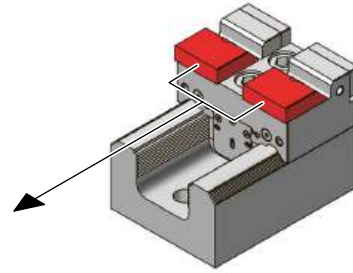

#### Die Fakten beim Linearspannsystem

Verstellbereich: 0- 5,0 mm  
Spannkraft: Bis 3'200 daN

#### Vorteile beim Linearspannsystem:

- Spannstockähnliches Spannen
- Prozesssichere Positionierung der zweiten Aufspannung
- Gut geeignet für die Erstellung von individuellen Formbacken
- Sicherer Halt mit Prägetechnik

#### Facts for linear clamp modules

Jaw range: 0- 5,0 mm  
Clamping force: up to 3'200 daN

#### Advantages linear jaws:

- Similar clamp as conventional vise
- Good for shaped jaws
- Secure clamped with direct stamping jaws
- Higher accuracy

### Universalnutstein Universal nut

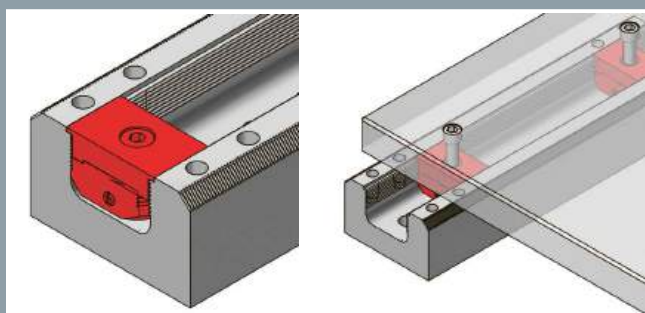

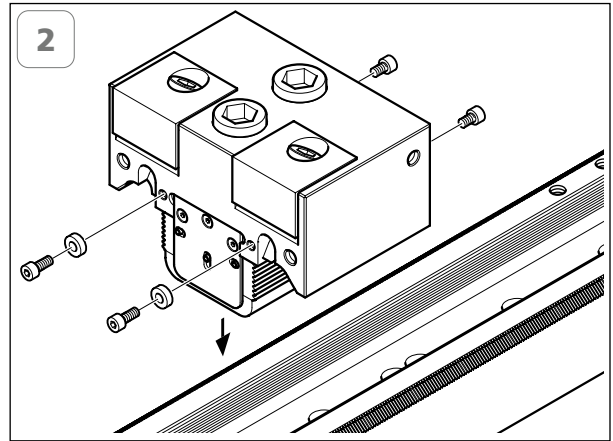
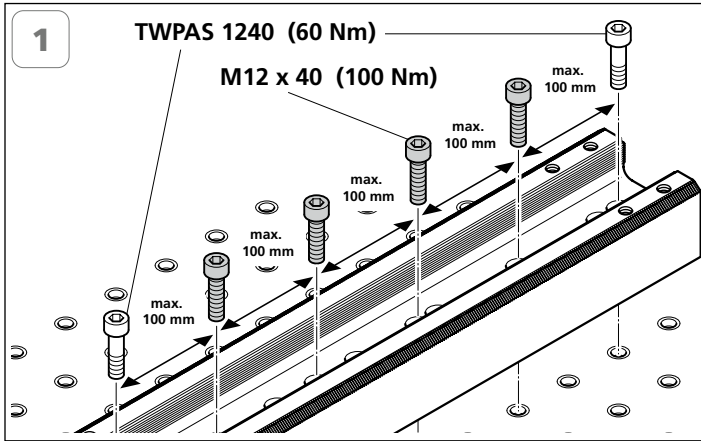

Ineinandergreifen der Verzahnung prüfen  
Check matching of the teeth

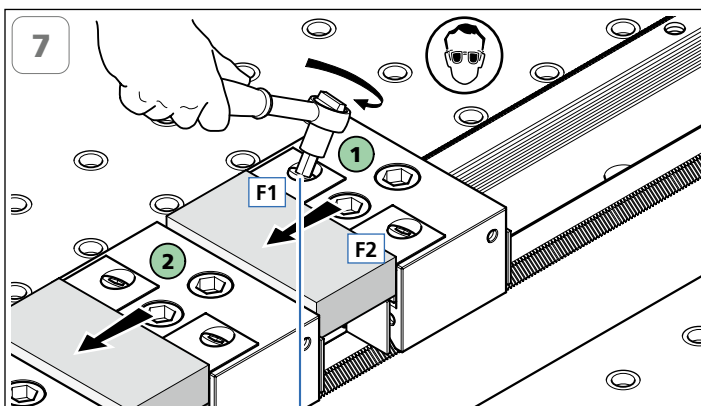
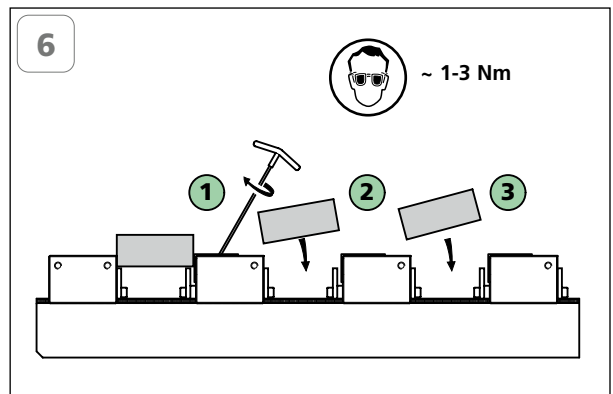
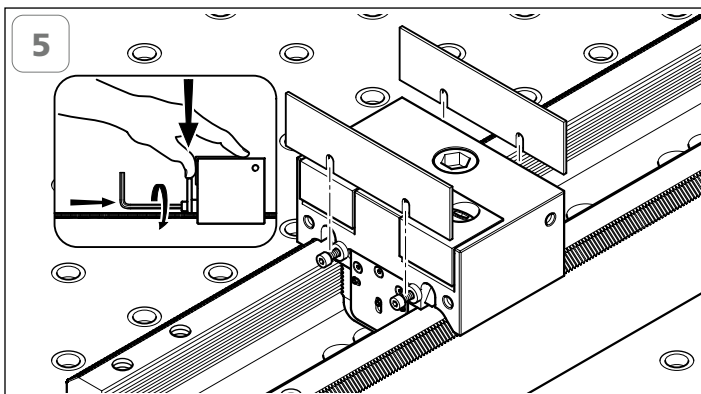
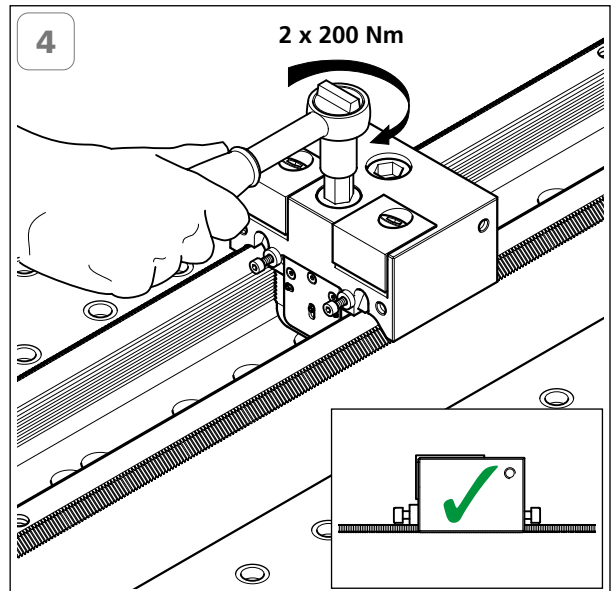
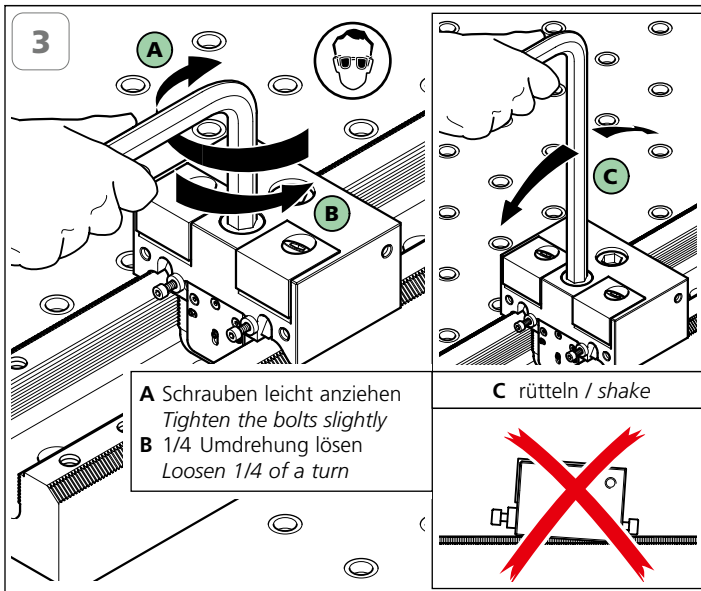

max. Drehmoment beachten  
Observe max. torque

Schraube Screw	Drehmoment Torque		Spannkraft (F1 & F2) Workholding force (F1 & F2)		
	Nm	(lb-ft)	~daN	~(lb)	~t
M10	10	7,4	= 1200	2'650	1,2
	20	14,8	= 2700	5'950	2,7
	30	22,2	= 4100	9'040	4,1
	40	29,5	= 5600	12'350	5,6
	50	37,0	= 7000	15'430	7,0

max. Nm

**ACHTUNG / CAUTION**

**WICHTIG:** Die angegebenen Drehmomente sind die absoluten Maximalwerte. Über die Spannkraften gibt die untenstehende Tabelle Auskunft.

**IMPORTANT:** The torque numbers specified represent the absolute maximum. The table at the bottom of this page provides further information on the workholding forces.

Schraube Screw	Drehmoment Torque		Spannkraft (F1 & F2) Workholding force (F1 & F2)		
	Nm	(lb-ft)	~daN	~(lb)	~t
M10	10	7,4	= 1200	2'650	1,2
	20	14,8	= 2700	5'950	2,7
	30	22,2	= 4100	9'040	4,1
	40	29,5	= 5600	12'350	5,6
	50	37,0	= 7000	15'430	7,0

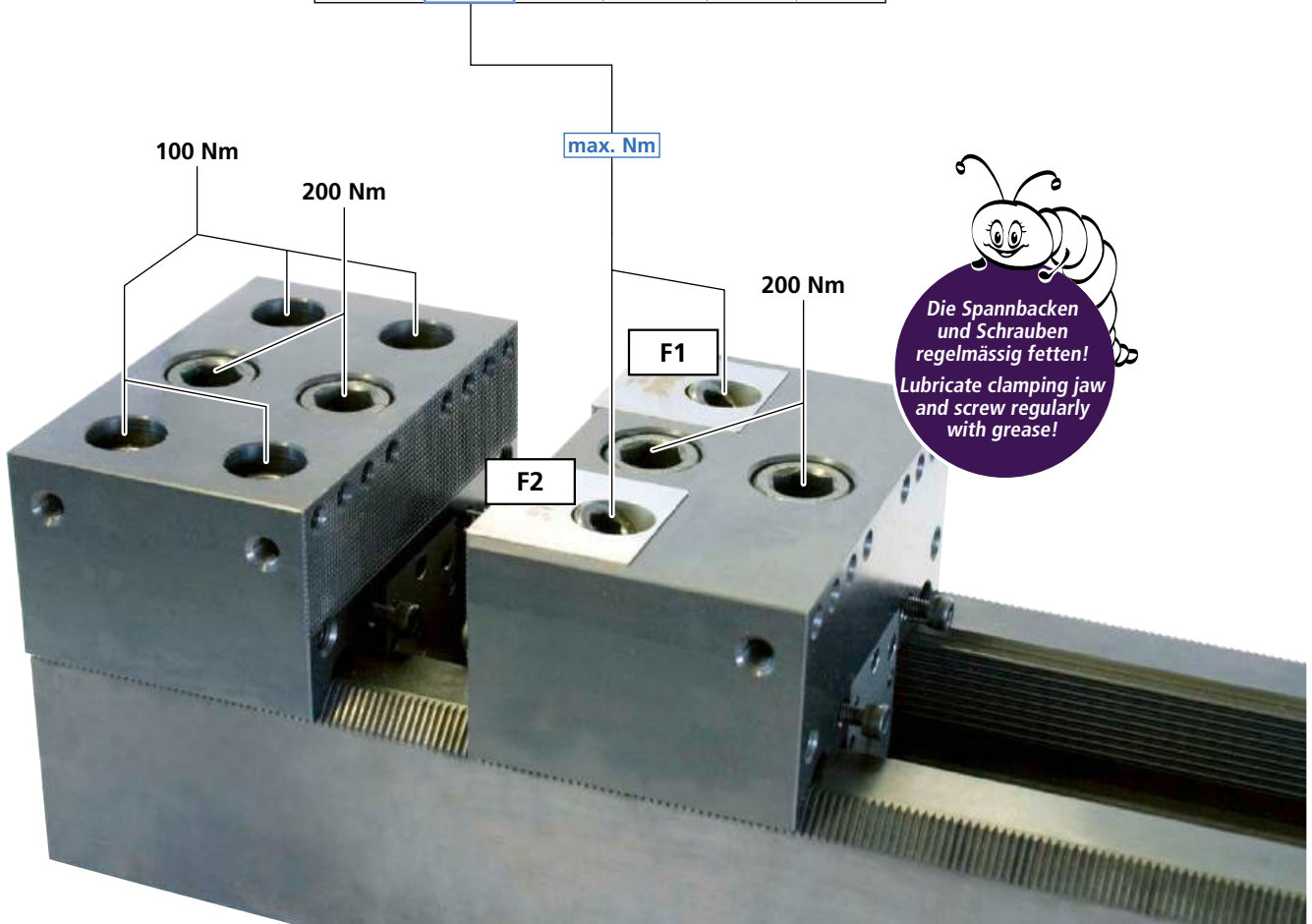

**WICHTIG:** Vor dem Positionieren der Spannmodule für ein neues Werkstück ist die Spannbacke ganz zurück zu stellen, dies gewährleistet eine sichere Spannung (siehe Bild A)!

**IMPORTANT:** Prior to setting up a new clamping module the clamping jaw of the vice module must be retracted all the way (see picture A)! This guaranties proper clamping of the new workpiece.

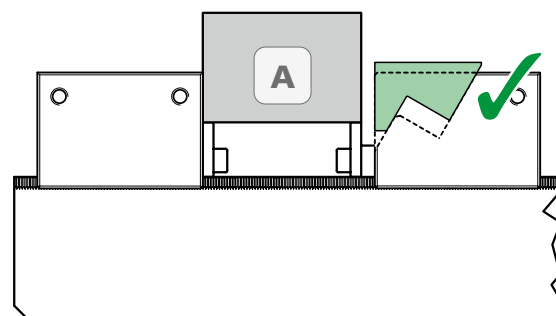
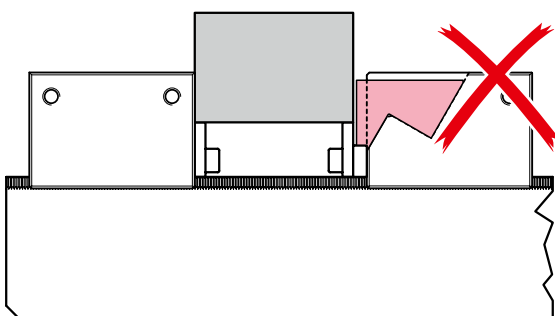

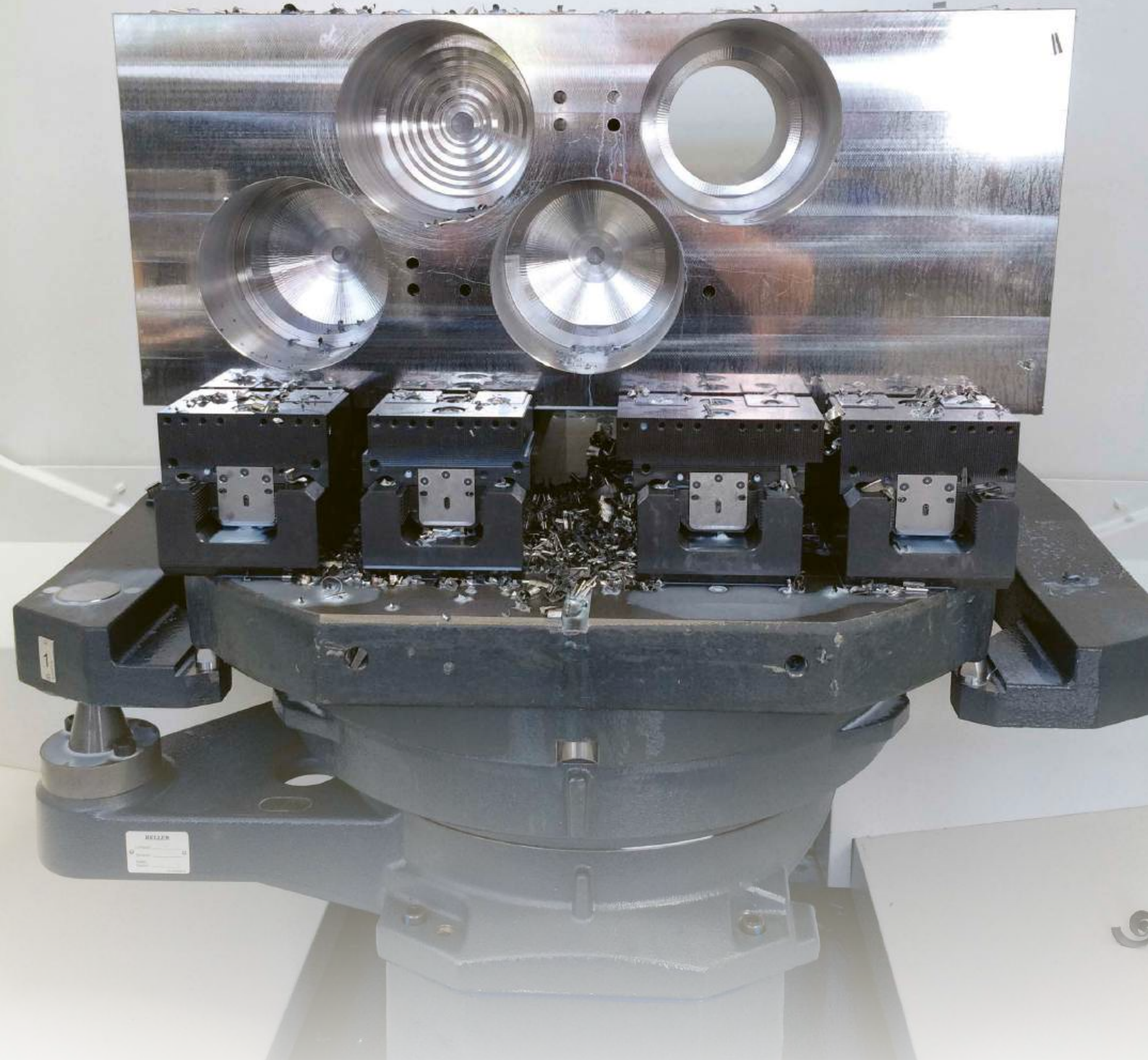

Material	42Cr Mo4
Bearbeitung mit Fräskopf	Ø 200
<i>Machining with milling head</i>	
Bohrer / Drills	Ø 124
Einspanntiefe / Clamping depth	24mm

**Apto Clamp in der Schwerzerspannung auf Heller 5-Achsen-Maschine**  
**Apto Clamp for heavy duty machining on a 5-axis machine**



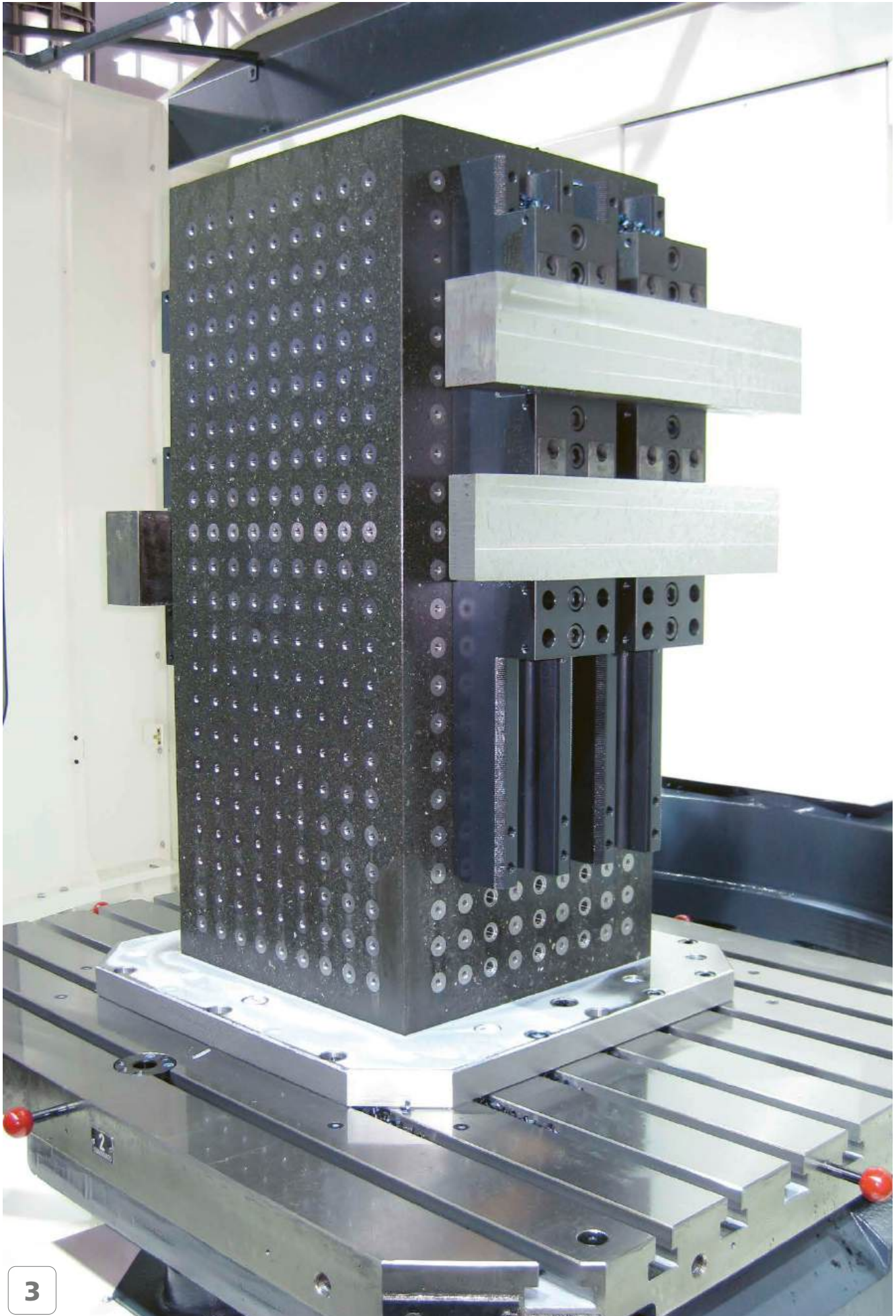

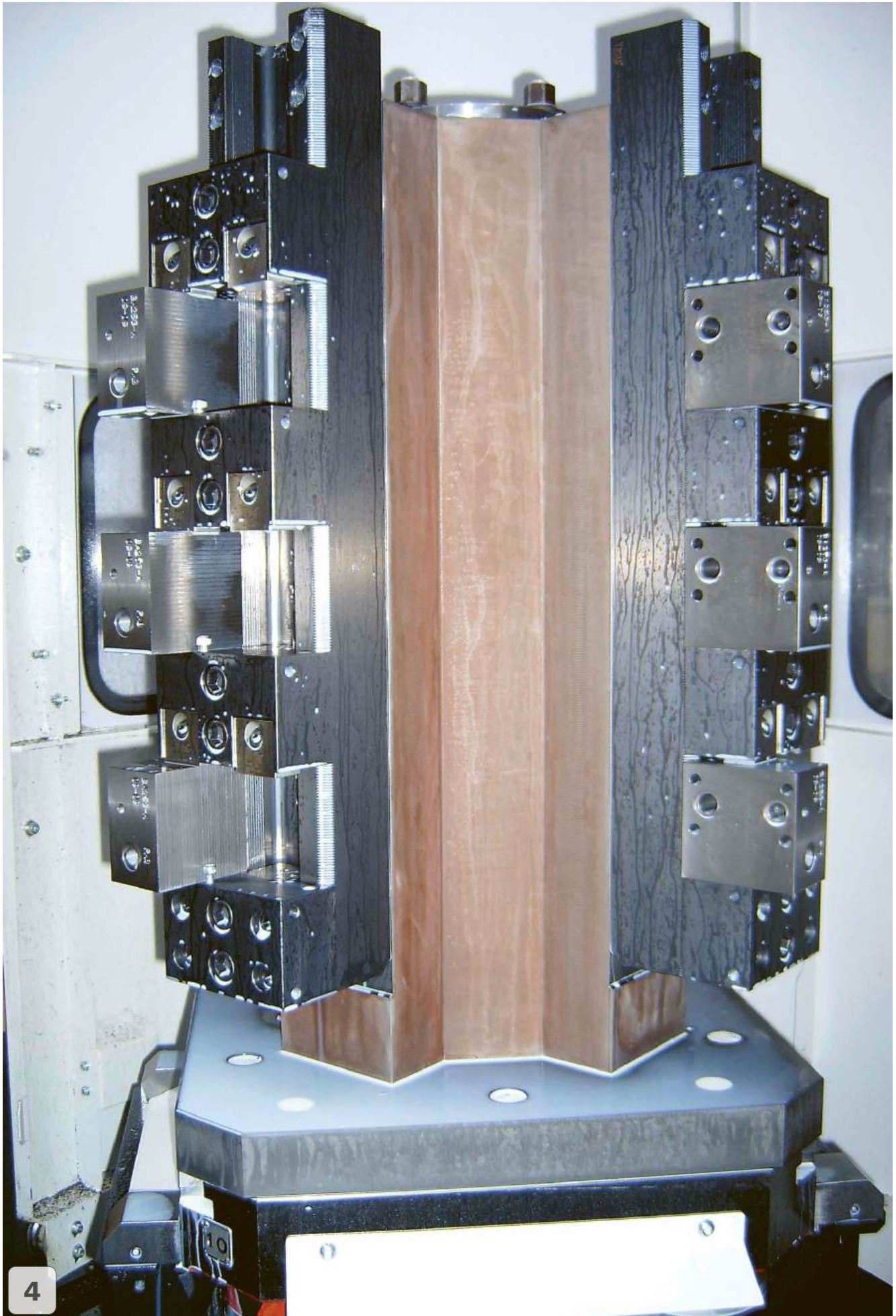

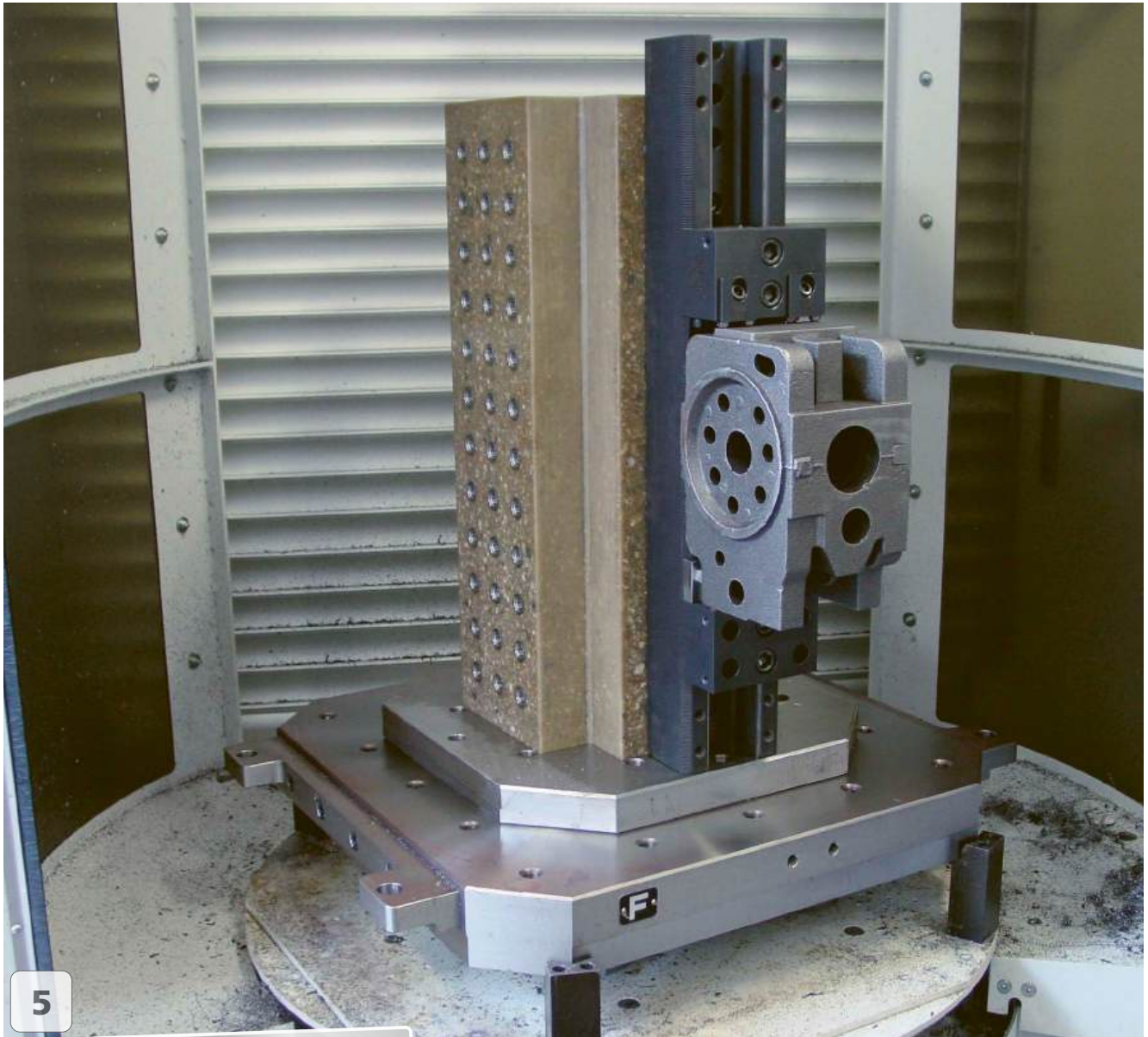

5

**VERTICAL** (3-4 ACHSEN/AXES)

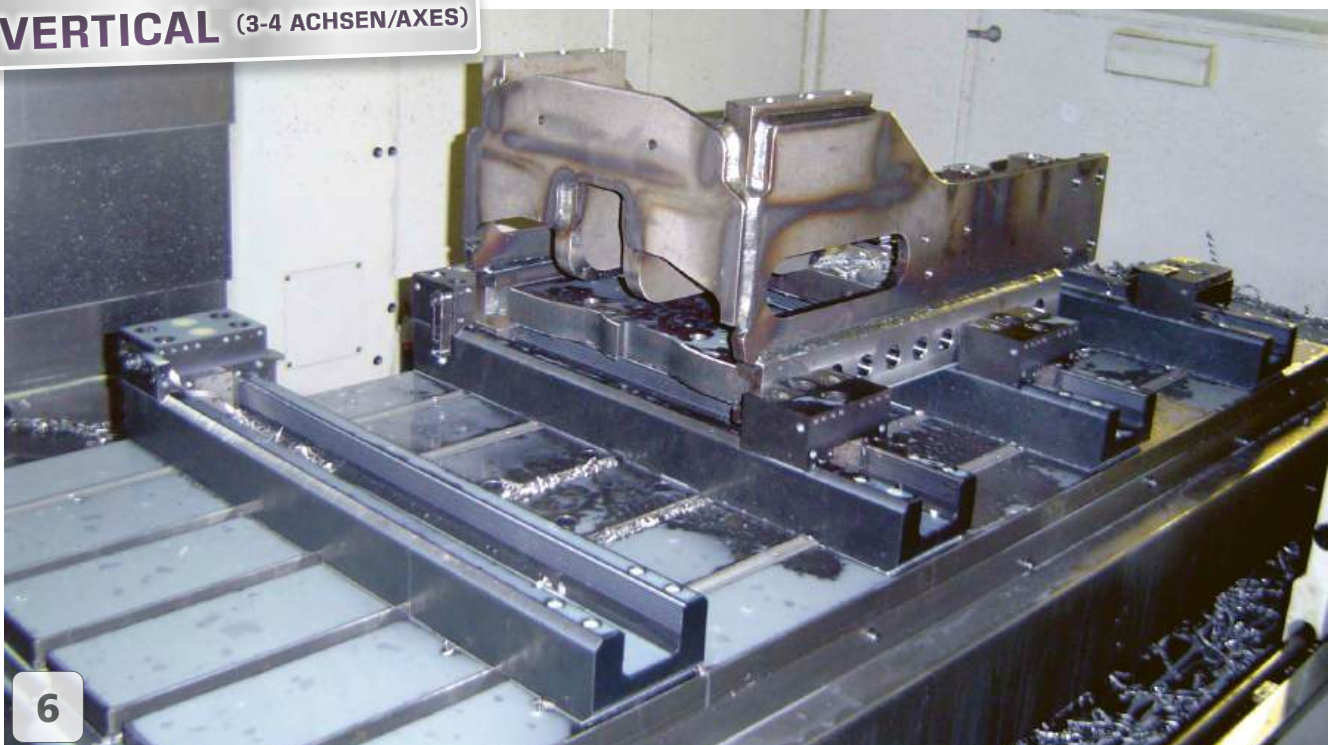

6

Es gibt zusätzlich Apto Clamp Module in angeschrägter Ausführung. Damit kann ein optimaler Zugang zum Werkstück bei der 5-Achsenmaschine gewährleistet werden. Die Spannmodule produzieren bis zu 7000daN (7 Tonnen) Spannkraft und sind für die Schwerzerspannung empfohlen.

*We offer Apto Clamp modules in slanted version. That ensures an optimal access to the workpieces on 5-axis machines. The clamping modules produce up to 7000daN (7 tons) clamping force and are recommended for heavy roughing workholding.*



**Gute Zugänglichkeit auf 5-Achs Maschine, gespannt mit 2 x 7 Tonnen!**  
*Fast setup fast clamping and perfect for short tool holders!*

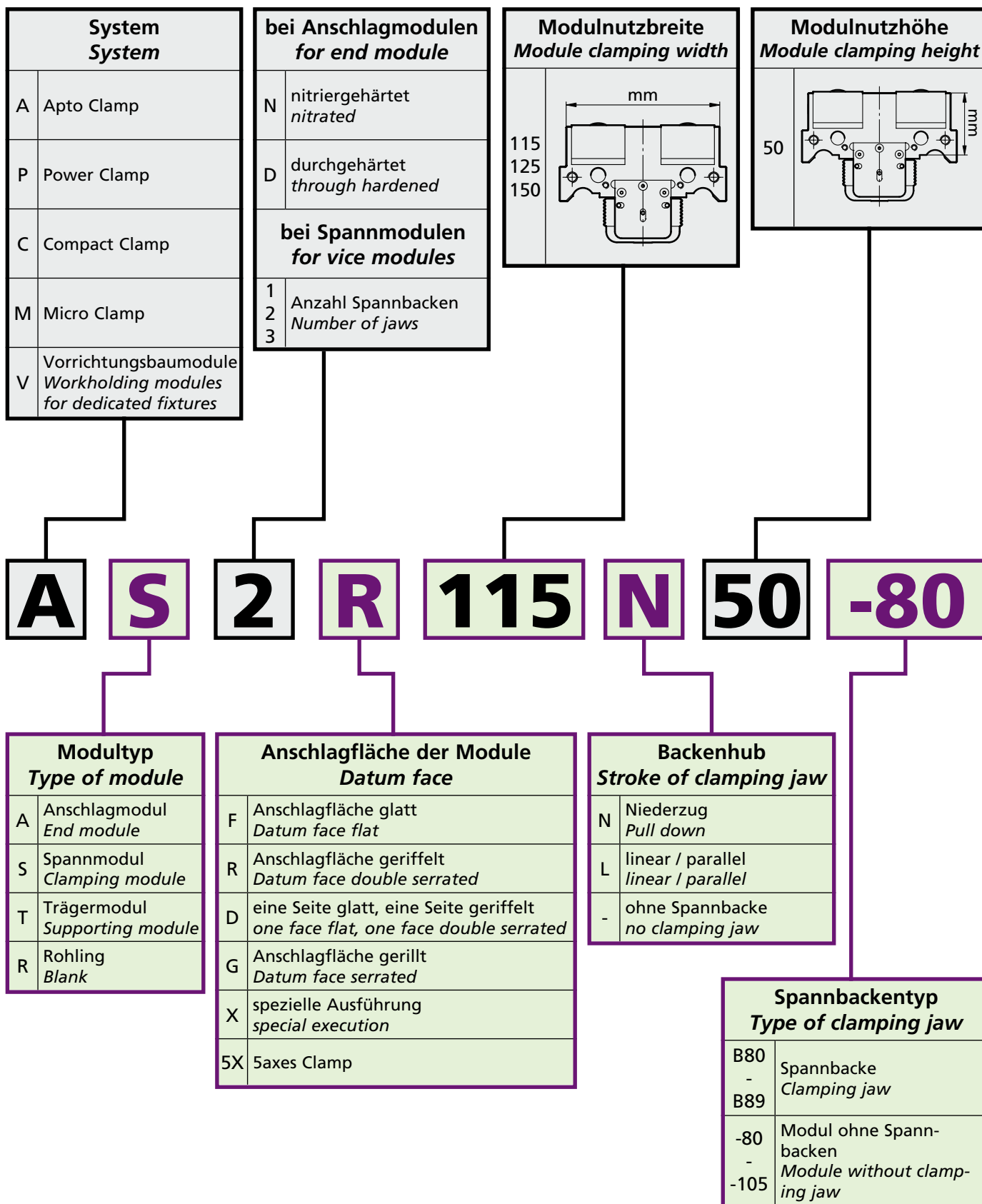

ACB4050400 kg ~18

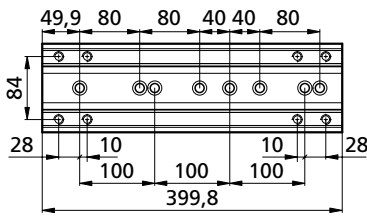

ACB4050700 kg ~31

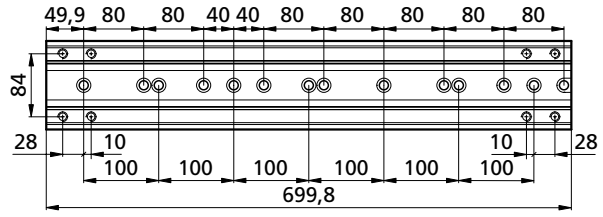

ACB4050450 kg ~20

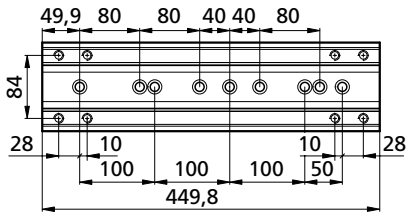

ACB4050750 kg ~33

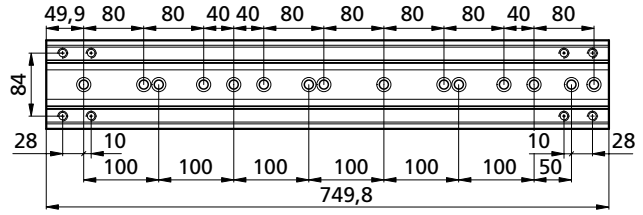

ACB4050500 kg ~22

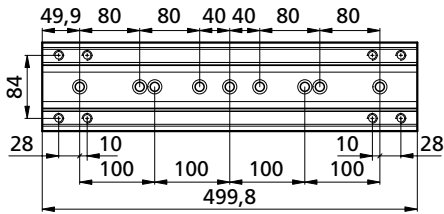

ACB4050800 kg ~35

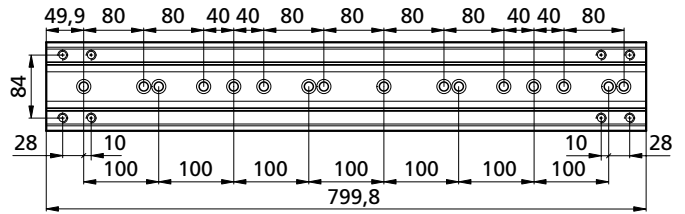

ACB4050550 kg ~24

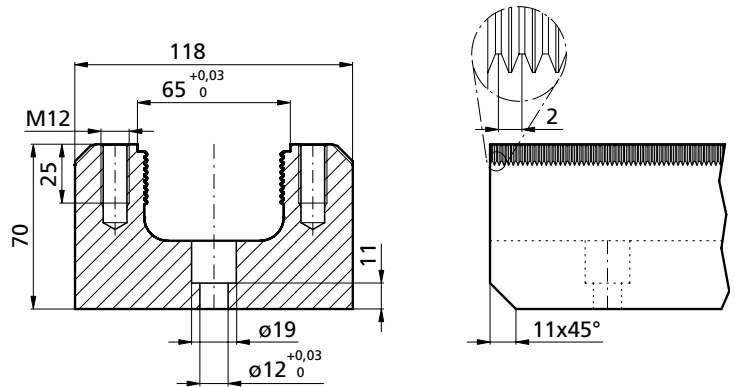
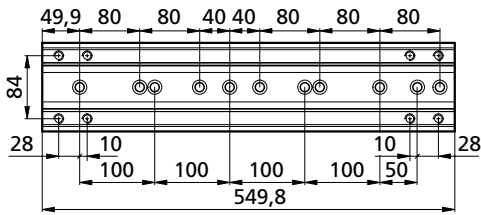

ACB4050600 kg ~26

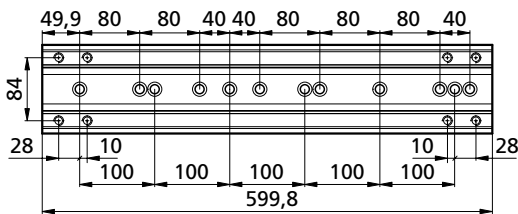

ACB4050650 kg ~29

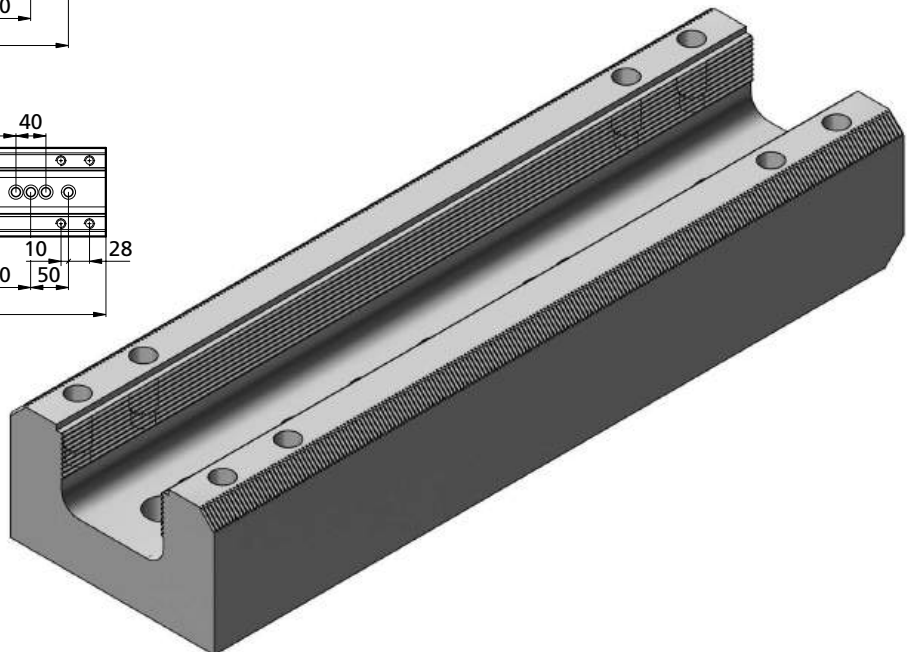
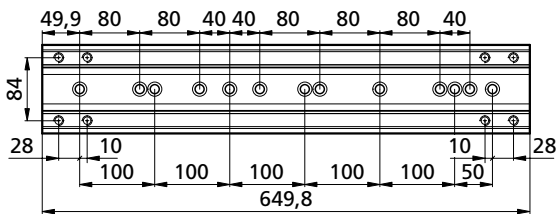

# Spannmodule Clamping module

AS2R/F115N50-80  
AS25X115N50-80

5axes  
aptoCLAMP

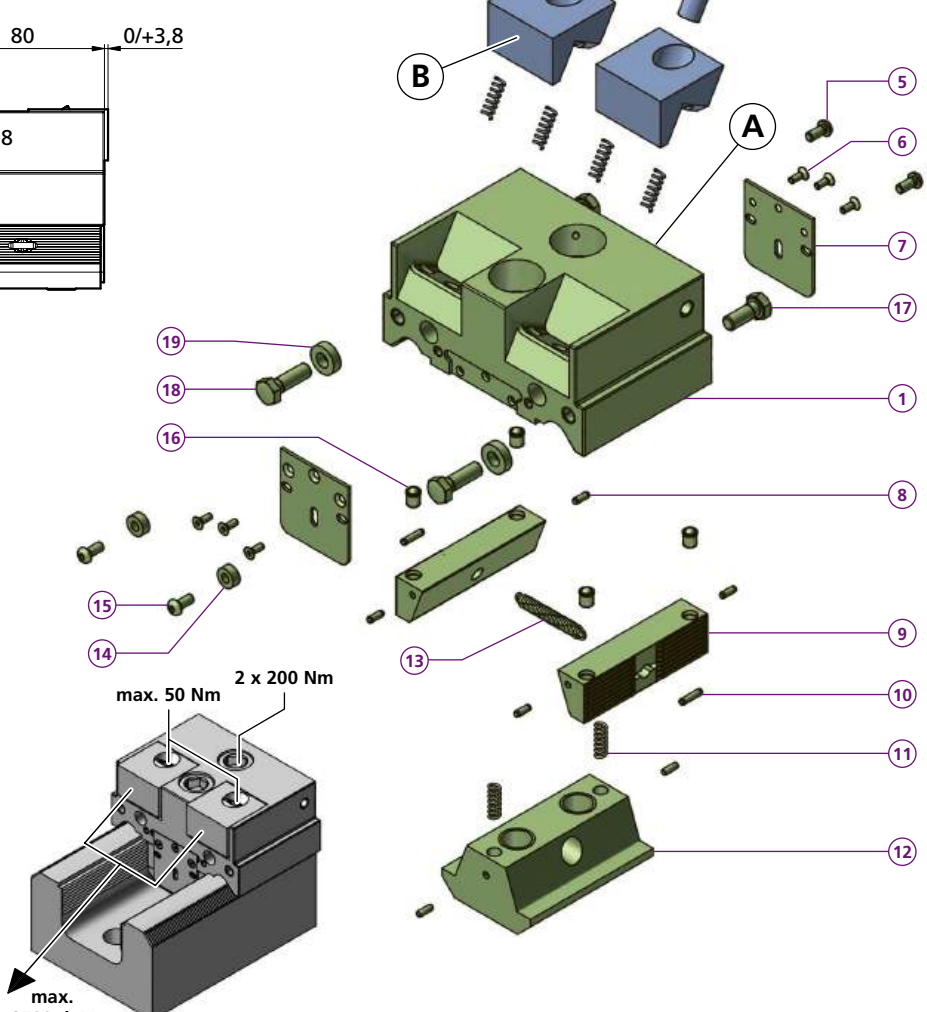
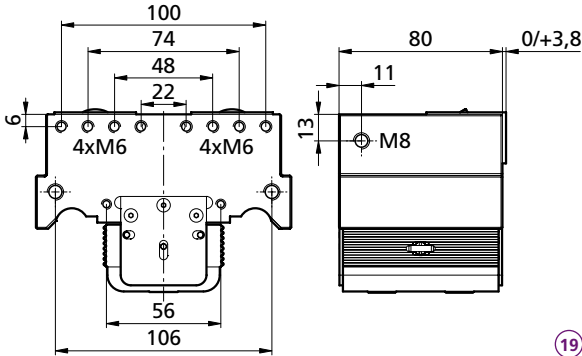
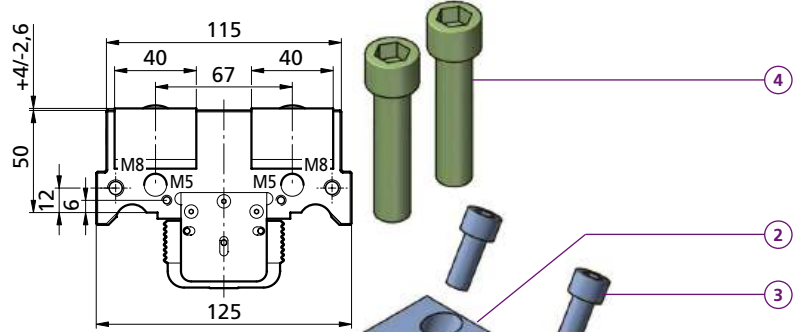
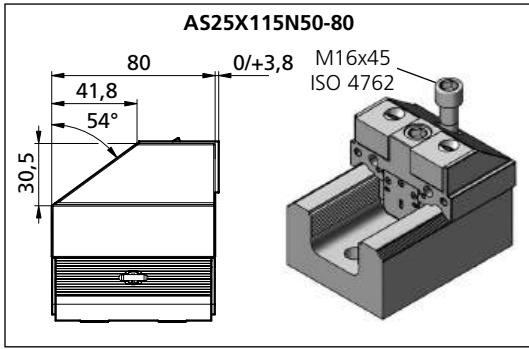

- AS25X115N50-80**
- 1x TF140678
  - 1x M16X45ISO4762
  - 1x M16X70ISO4762
  - 2x M8X20ISO4017
  - 2x ACD005
  - kg ~4,3
- AS2F115N50-80**
- 1x TF140676
- AS2R115N50-80**
- 1x TF140677
  - 2x
  - 2x M10X25ISO4762
  - 2x M16X70ISO4762
  - 2x M5X10ISO7380-1
  - 6x M3X6DIN7991
  - 2x ACBL4243
  - 6x Ø 3x8 VSM 12785
  - 2x ACSP7620
  - 2x Ø 3h 8x12 ISO 2338
  - 6x FED0618
  - 1x ACSV7632M16
  - 1x FED Ø 5,5x39
  - 2x PCD005
  - 2x M5X14ISO7380-1
  - 4x Ø 6-Niro SM1275-3
  - 2x M8X16ISO4017
  - 2x M8X20ISO4017
  - 2x ACD005
  - kg ~4,8

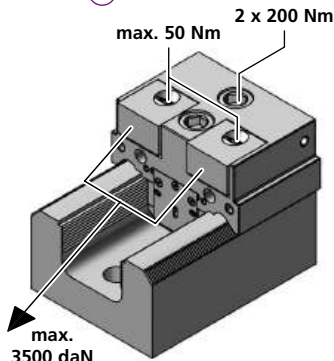

Bestellbeispiel / Ordering example: 1x AS2R115N50-80 & 2x B80

	B80	B80N	B81	B82	B82L33	B82HM	B83	B84	B89F	B89R
C	40	40	40	40	40	40	40	40	40	40
H	25	25	25	25	25	25	25	25	25	25
L	22	22	22	22,2	33	22,2	22	26,3	29	29
D	11	11	11	11	11	11	11	11	11	11
ø	15	15	15	15	15	15	15	15	15	15
i	56HRC	HV700 x0,2mm	56HRC	*	*	56HRC	HV700 x0,2mm	*	HV700 x0,2mm	HV700 x0,2mm
kg	~0,2	~0,2	~0,2	~0,2	~0,28	~0,2	~0,2	~0,2	~0,24	~0,24

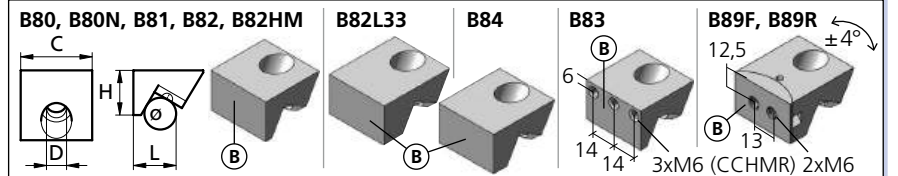

\* = weich / soft

HM = Hartmetallbeschichtet / Carbide coated

Separat bestellen / Order separately

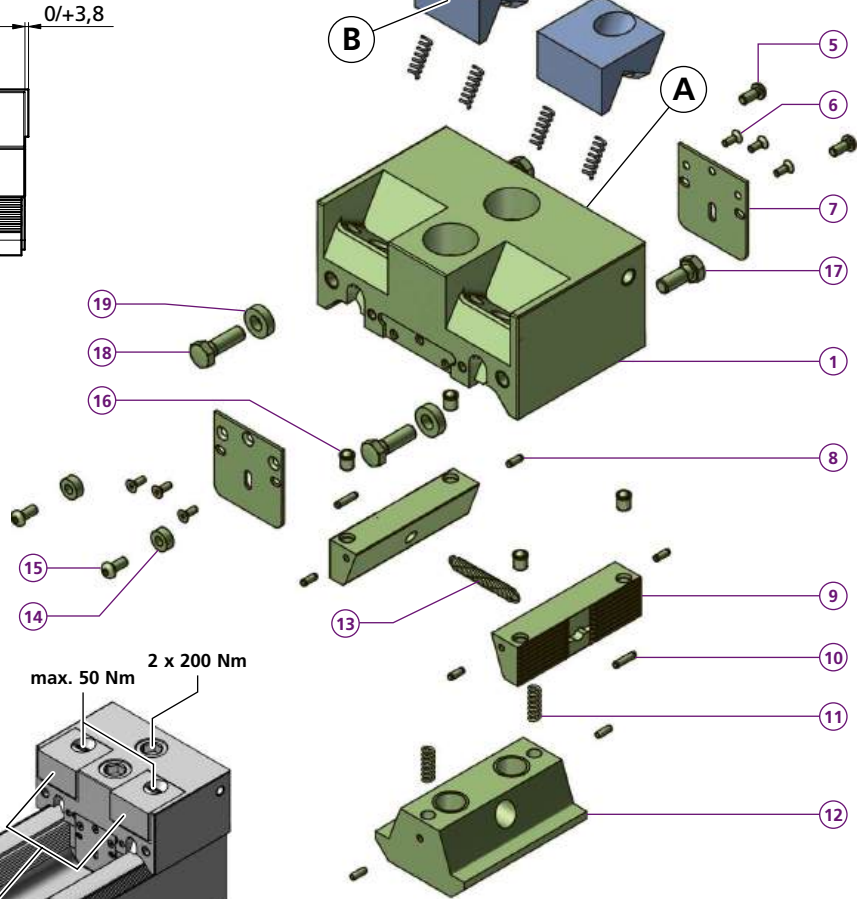
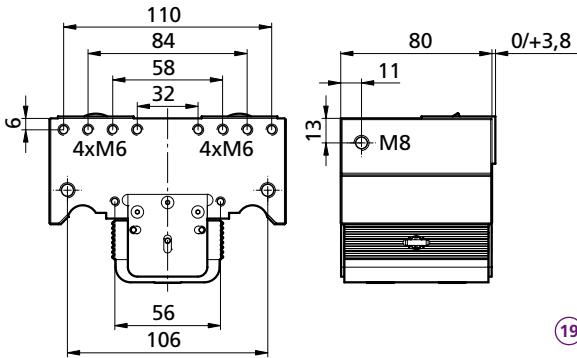
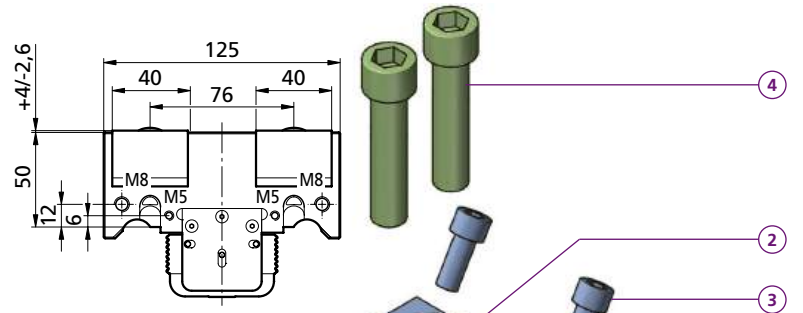
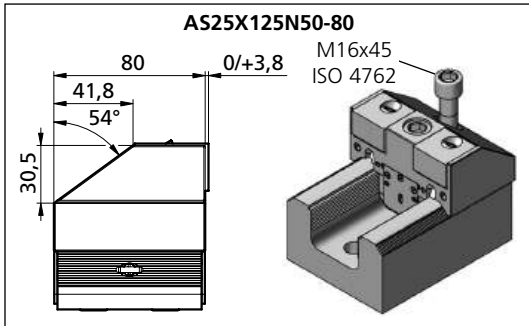

- AS25X125N50-80**
- 1x TF140682
  - 1x M16X45ISO4762
  - 1x M16X70ISO4762
  - 2x M8X20ISO4017
  - 2x ACD005
- kg ~4,3
- AS2F125N50-80**
- 1x TF140680
- AS2R125N50-80**
- 1x TF140681
  - 2x
  - 2x M10X25ISO4762
  - 2x M16X70ISO4762
  - 2x M5X10ISO7380-1
  - 6x M3X6DIN7991
  - 2x ACBL4243
  - 6x Ø 3x8 BN 879
  - 2x ACSP7620
  - 2x Ø 3h 8x12 ISO 2338
  - 6x FED0618
  - 1x ACSK7632M16
  - 1x FED Ø 5,5x39
  - 2x PCD005
  - 2x M5X14ISO7380-1
  - 4x Ø 6-Niro SM1275-3
  - 2x M8X16ISO4017
  - 2x M8X20ISO4017
  - 2x ACD005
- kg ~4,9

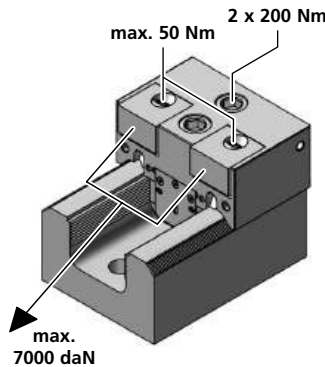

max. 7000 daN

Bestellbeispiel / Ordering example: 1x AS2R125N50-80 & 2x B80

	B80	B80N	B81	B82	B82L33	B82HM	B83	B84	B89F	B89R
C	40	40	40	40	40	40	40	40	40	40
H	25	25	25	25	25	25	25	25	25	25
L	22	22	22	22,2	33	22,2	22	26,3	29	29
D	11	11	11	11	11	11	11	11	11	11
ø	15	15	15	15	15	15	15	15	15	15
i	56HRC	HV700 x0,2mm	56HRC	*	*	56HRC	HV700 x0,2mm	*	HV700 x0,2mm	HV700 x0,2mm
kg	~0,2	~0,2	~0,2	~0,2	~0,28	~0,2	~0,2	~0,2	~0,24	~0,24

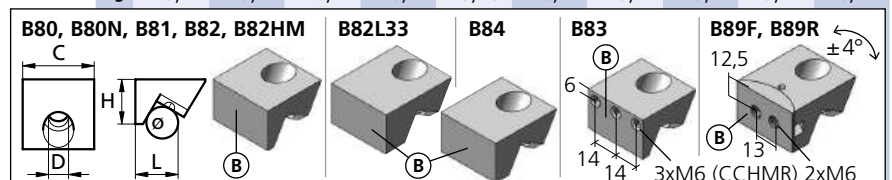

HM = Hartmetallbeschichtet / Carbide coated

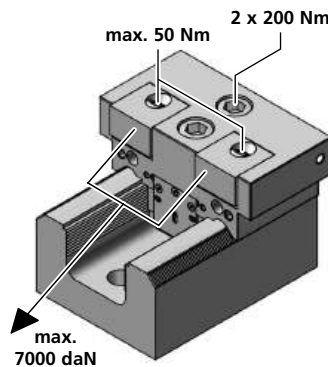
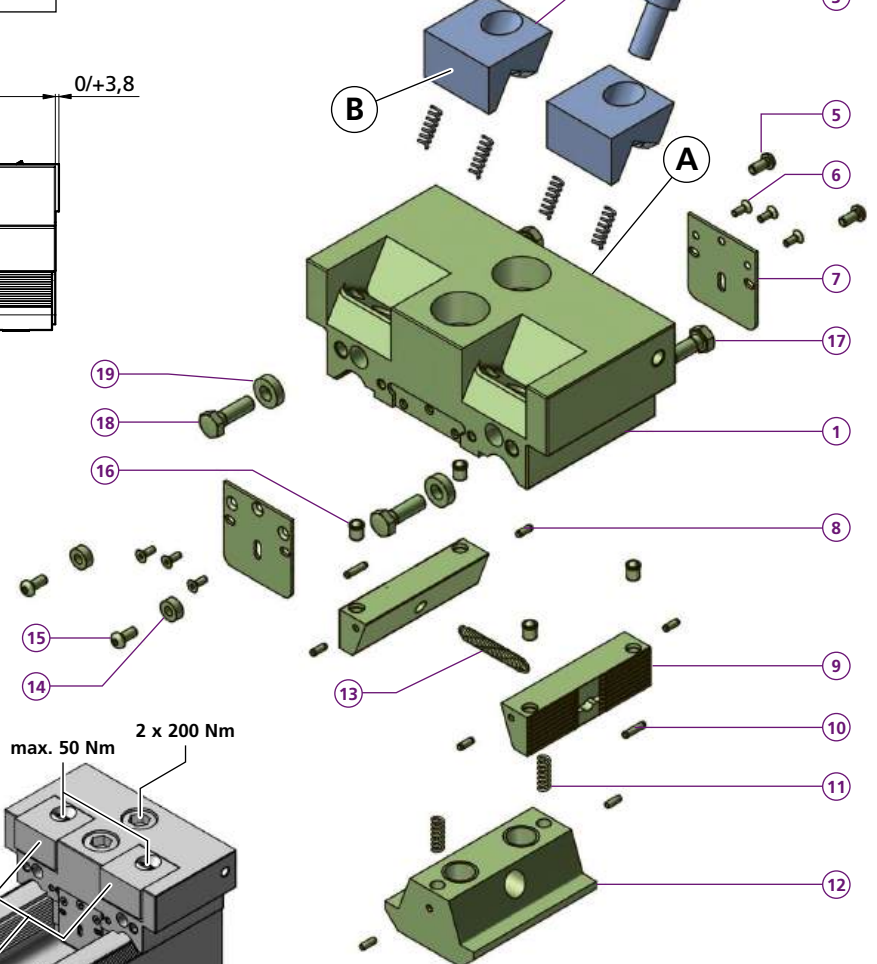
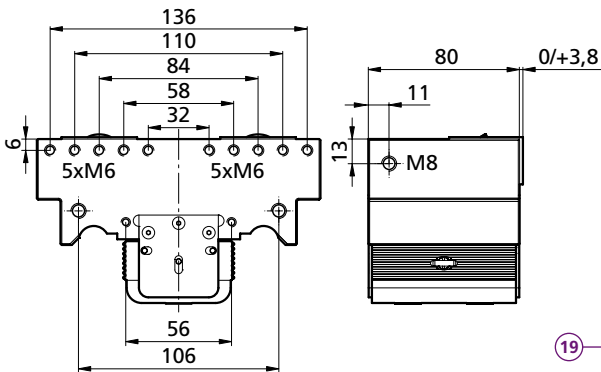
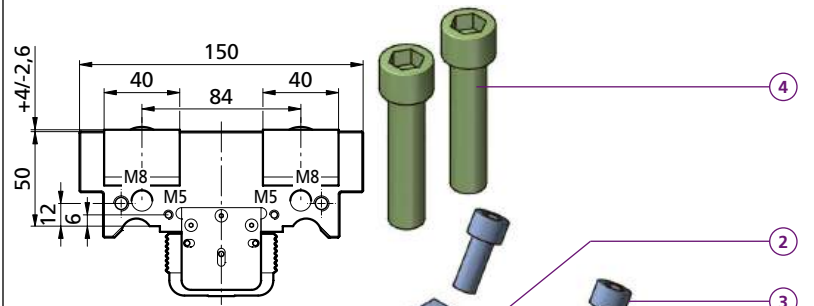
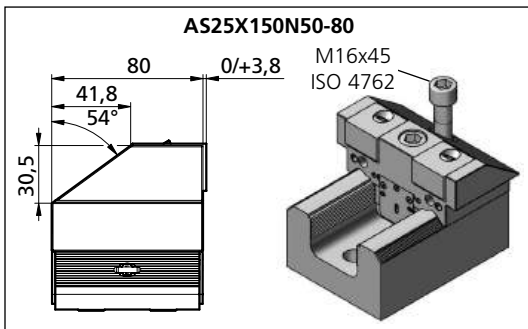

- AS25X150N50-80**
- 1 1x TF140687
  - 4 1x M16X45ISO4762
  - 4 1x M16X70ISO4762
  - 18 2x M8X20ISO4017
  - 19 2x ACD005
  - kg ~4,7
- AS2F150N50-80**
- 1 1x TF140685
- AS2R150N50-80**
- 1 1x TF140686
  - 2 2x
  - 3 2x M10X25ISO4762
  - 4 2x M16X70ISO4762
  - 5 2x M5X10ISO7380-1
  - 6 6x M3X6DIN7991
  - 7 2x ACBL4243
  - 8 6x Ø 3x8 VSM 12785
  - 9 2x ACSP7620
  - 10 2x Ø 3h 8x12 ISO 2338
  - 11 6x FED0618
  - 12 1x ACSK7632M16
  - 13 1x FED Ø 5,5x39
  - 14 2x PCD005
  - 15 2x M5X14ISO7380-1
  - 16 4x Ø 6-Niro SM1275-3
  - 17 2x M8X16ISO4017
  - 18 2x M8X20ISO4017
  - 19 2x ACD005
  - kg ~5,4

Bestellbeispiel / Ordering example: 1x AS2R150N50-80 & 2x B80

	B80	B80N	B81	B82	B82L33	B82HM	B83	B84	B89F	B89R
C	40	40	40	40	40	40	40	40	40	40
H	25	25	25	25	25	25	25	25	25	25
L	22	22	22	22,2	33	22,2	22	26,3	29	29
D	11	11	11	11	11	11	11	11	11	11
e	15	15	15	15	15	15	15	15	15	15
i	56HRC	HV700 x0,2mm	56HRC	*	*	56HRC	HV700 x0,2mm	*	HV700 x0,2mm	HV700 x0,2mm
kg	~0,2	~0,2	~0,2	~0,2	~0,28	~0,2	~0,2	~0,2	~0,24	~0,24

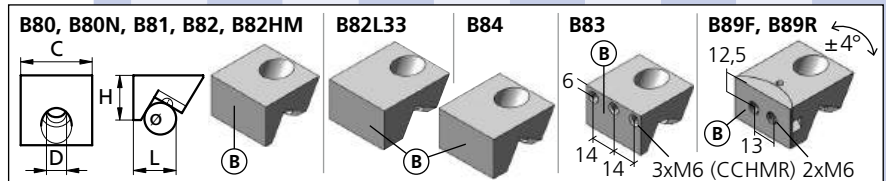

\* = weich / soft

HM = Hartmetallbeschichtet / Carbide coated

Separat bestellen / Order separately

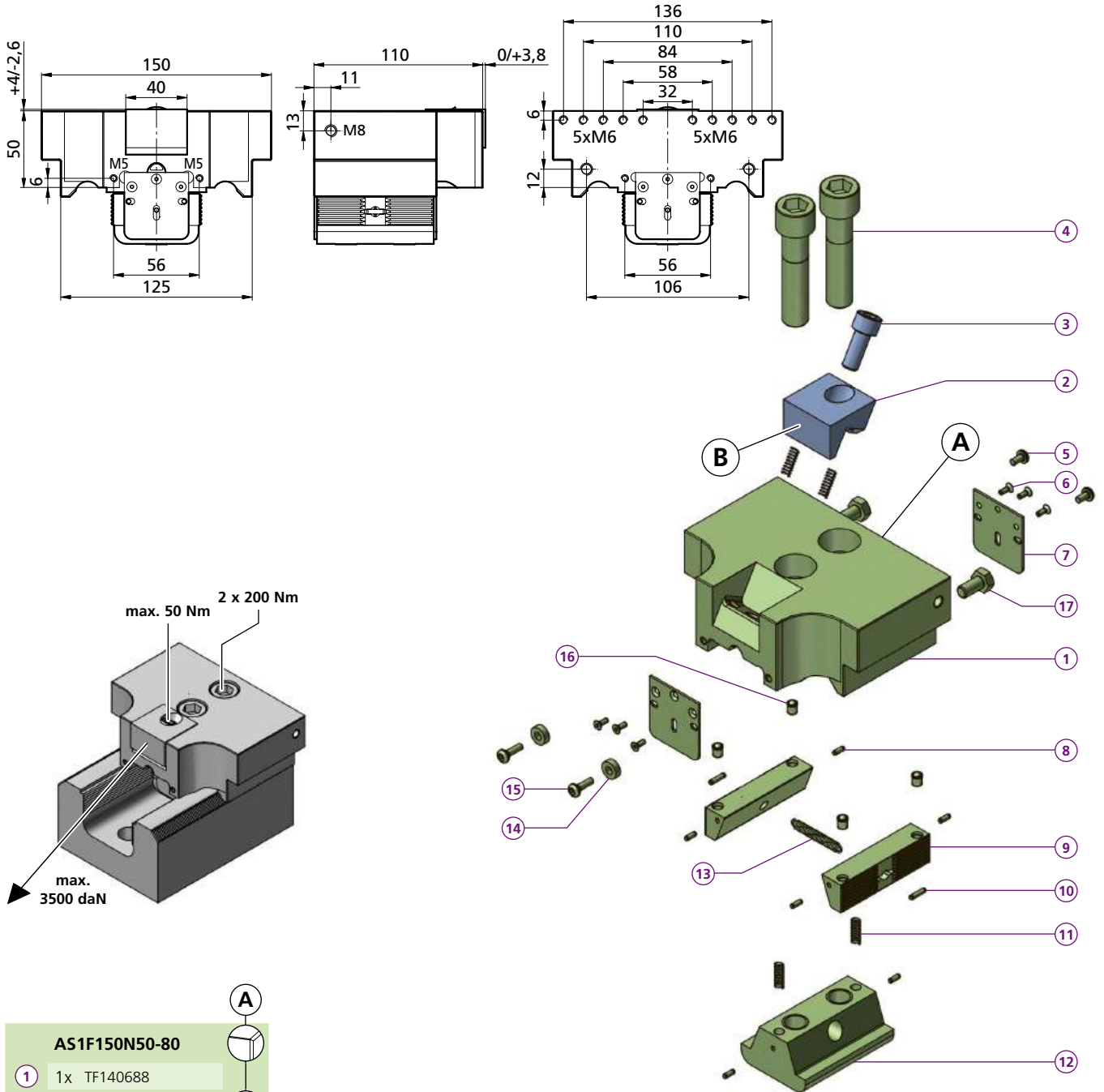

- AS1F150N50-80**
- ① 1x TF140688
- AS1R150N50-80**
- ① 1x TF140689
- ② 2x
- ③ 1x **M10X25ISO4762**
- ④ 2x **M16X70ISO4762**
- ⑤ 2x **M5X10ISO7380-1**
- ⑥ 6x M3X6DIN7991
- ⑦ 2x ACBL4243
- ⑧ 6x Ø 3x8 VSM 12785
- ⑨ 2x ACSP7620
- ⑩ 2x Ø 3h 8x12 ISO 2338
- ⑪ 4x **FED0618**
- ⑫ 1x ACSK7632M16
- ⑬ 1x FED Ø 5,5x39
- ⑭ 2x **PCD005**
- ⑮ 2x **M5X14ISO7380-1**
- ⑯ 4x Ø 6-Niro SM1275-3
- ⑰ 2x M8X16ISO4017
- kg ~6,6

Bestellbeispiel / Ordering example: 1x AS1R150N50-80 & 1x B80

	B80	B80N	B81	B82	B82L33	B82HM	B83	B84	B89F	B89R
<b>C</b>	40	40	40	40	40	40	40	40	40	40
<b>H</b>	25	25	25	25	25	25	25	25	25	25
<b>L</b>	22	22	22	22,2	33	22,2	22	26,3	29	29
<b>D</b>	11	11	11	11	11	11	11	11	11	11
<b>e</b>	15	15	15	15	15	15	15	15	15	15
<b>i</b>	56HRC	HV700 x0,2mm	56HRC	*	*	56HRC	HV700 x0,2mm	*	HV700 x0,2mm	HV700 x0,2mm
<b>kg</b>	~0,2	~0,2	~0,2	~0,2	~0,28	~0,2	~0,2	~0,2	~0,24	~0,24

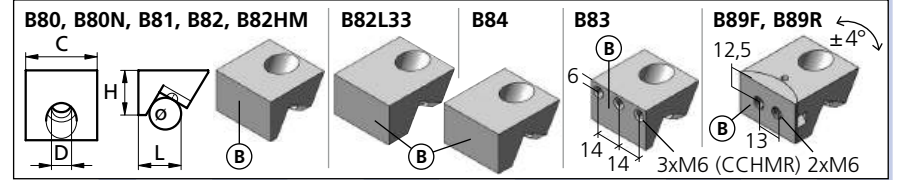

# AS2X125L50-105 AS25X125L50-105

# 5axes aptoCLAMP

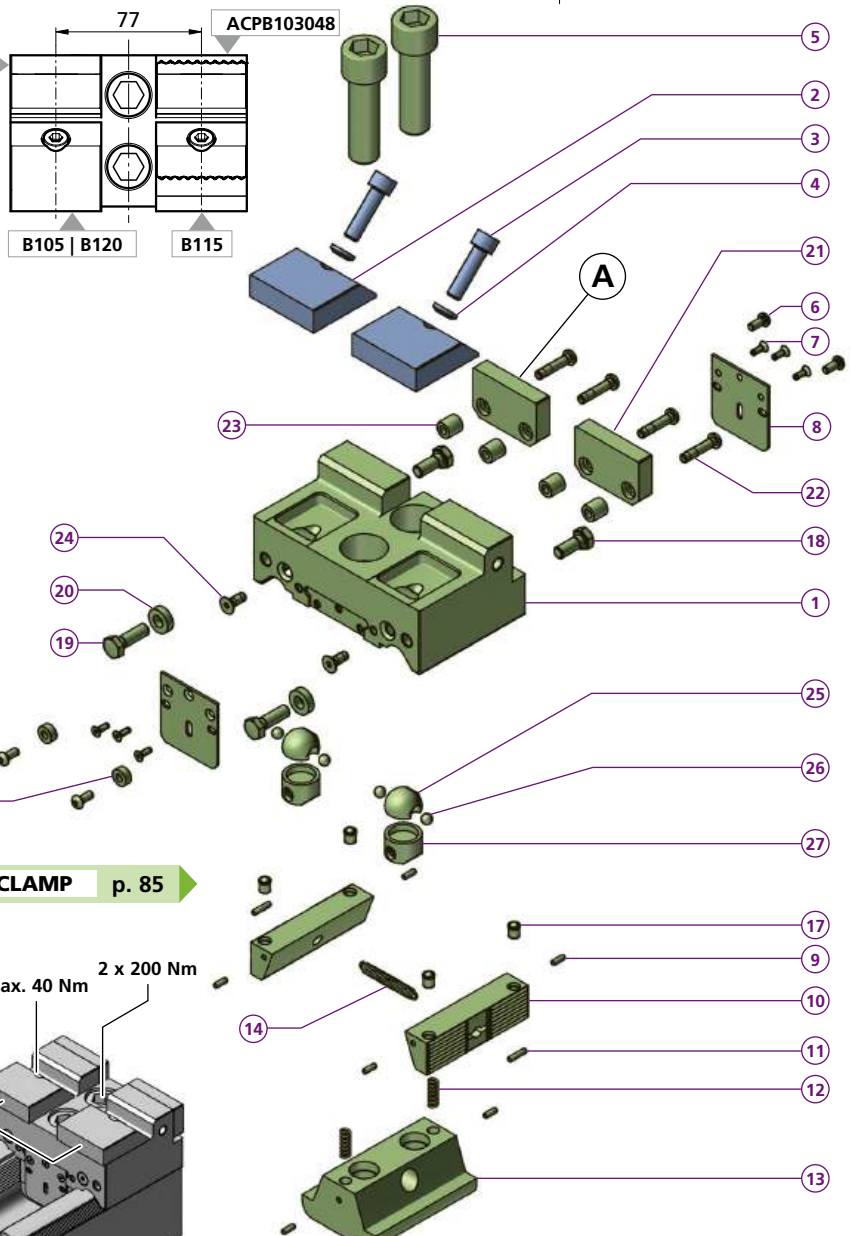
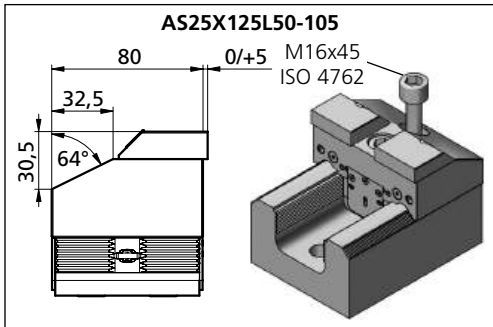
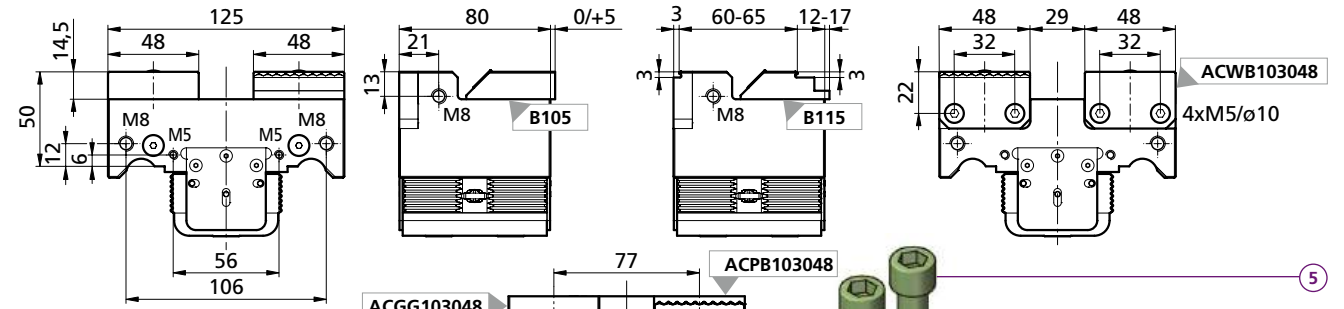

AS25X125L50-105	
1	1x TF140683
4	1x M16X45ISO4762
19	2x M8X20ISO4017
20	2x ACD005
kg	~4,3
AS2X125L50-105	
1	1x TF140684
2	2x <b>powerCLAMP</b> p. 85
3	2x M8X30ISO4762
4	2x PCUSR 14
5	2x M16X55ISO4762
6	2x M5X10ISO7380-1
7	6x M3X6DIN7991
8	2x ACBL4243
9	6x Ø 3x8 VSM 12785
10	2x ACSP7620
11	2x Ø 3h 8x12 ISO 2338
12	6x FED0618
13	1x ACSK7632M16
14	1x FED Ø 5,5x39
15	2x PCD005
16	2x M5X14ISO7380-1
17	4x Ø 6-Niro SM1275-3
18	2x M8X16ISO4017
19	2x M8X20ISO4017
20	2x ACD005
21	2x <b>ACWB103048</b>
22	4x M5X20ISO7380-1
23	4x Ø 5,2 ISO 4247
24	2x M5x10 DIN 7991
25	2x PCKMR45M8
26	4x d=6 DIN 5401
27	2x TS120001-04
kg	~4,5

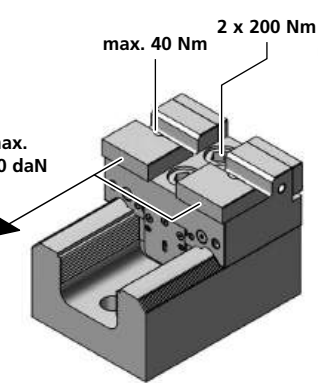

ACGGB103048	
*ACWB103048	
ACPB103048	
ACWB103048	
ACPB103048	

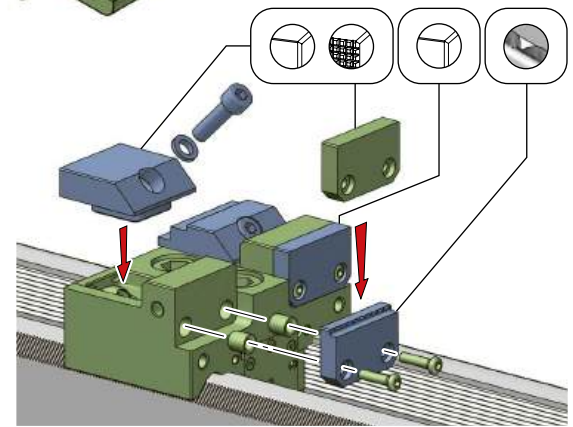

Bestellbeispiel / Ordering example:  
1x AS2X125L50-150 & 2x B105 & 2x ACGGB103048

Separat bestellen / Order separately

\* = weich / soft

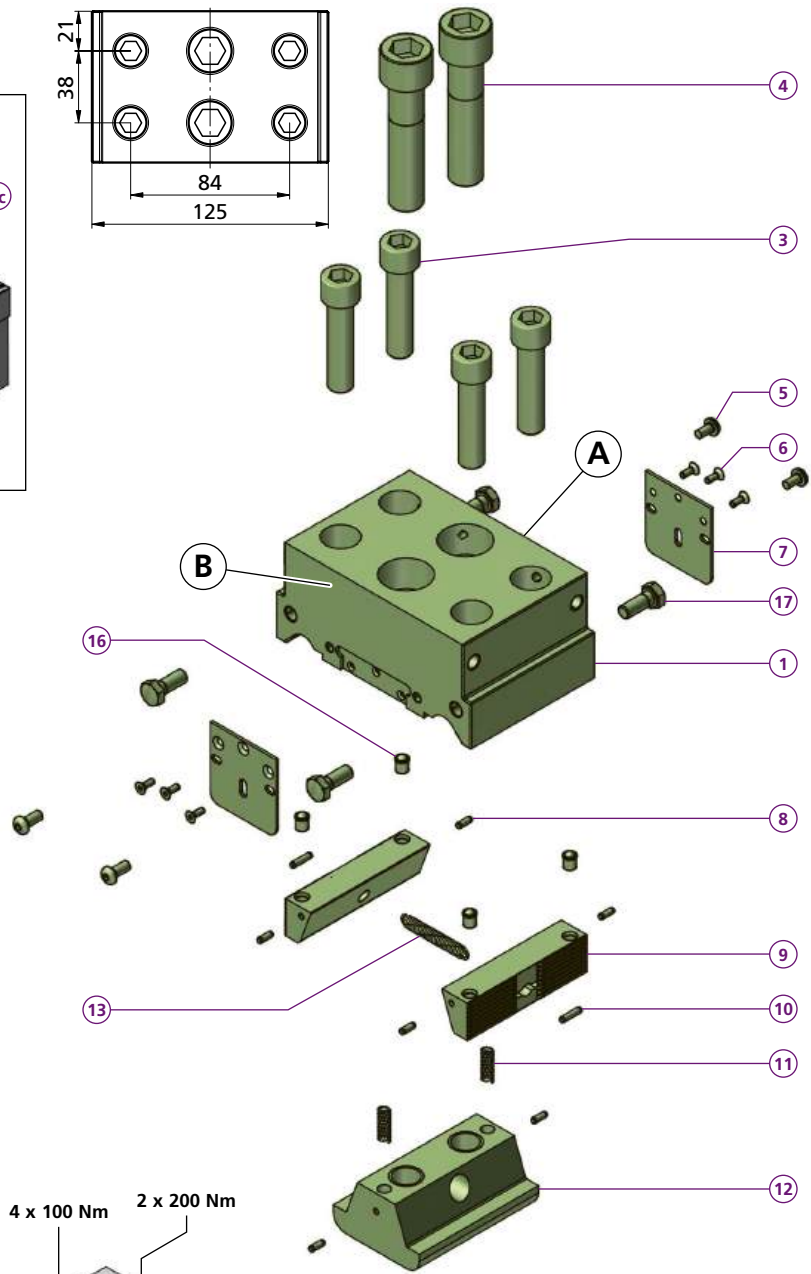
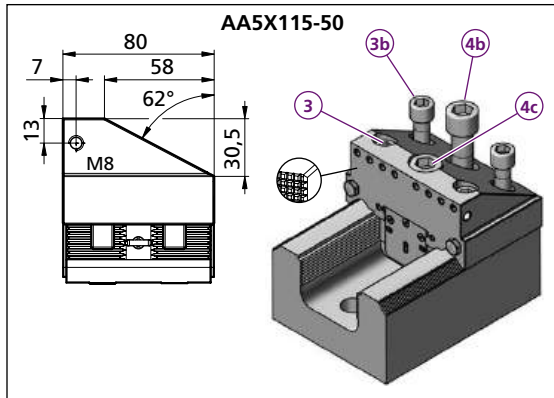
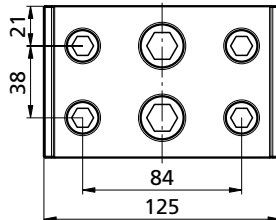
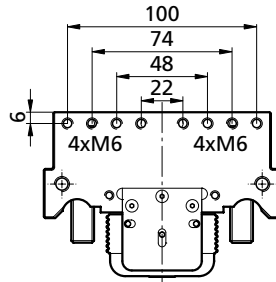
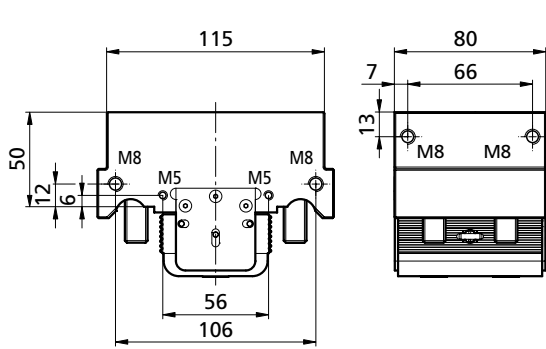

- AAND115-50**
- 1x TF140690
  - 4x M12X50ISO4762
  - 2x M16X70ISO4762
  - 4x M5X10ISO7380-1
  - 6x M3X6DIN7991
  - 2x ACBL4243
  - 6x Ø 3x8 VSM 12785
  - 2x ACS P7620
  - 2x Ø 3h 8x12 ISO 2338
  - 2x FED0618
  - 1x ACSK7632M16
  - 1x FED Ø 5,5x39
  - 4x Ø 6-Niro SM1275-3
  - 4x M8X16ISO4017
- kg ~4,7

- AA5X115-50**
- 1x TF140691
  - 2x M12X50ISO4762
  - 2x M12X30ISO4762
  - 1x M16X65ISO4762
  - 1x M16X45ISO4762
  - 2x M5X10ISO7380-1
  - 2x M8X16ISO4017
- kg ~4,6

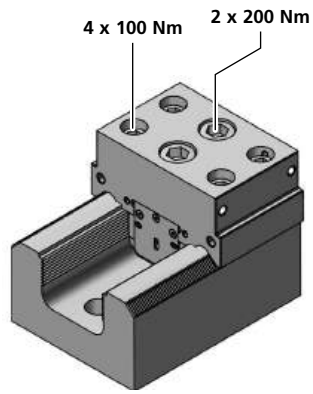

Bestellbeispiel / Ordering example: **AAND115-50**

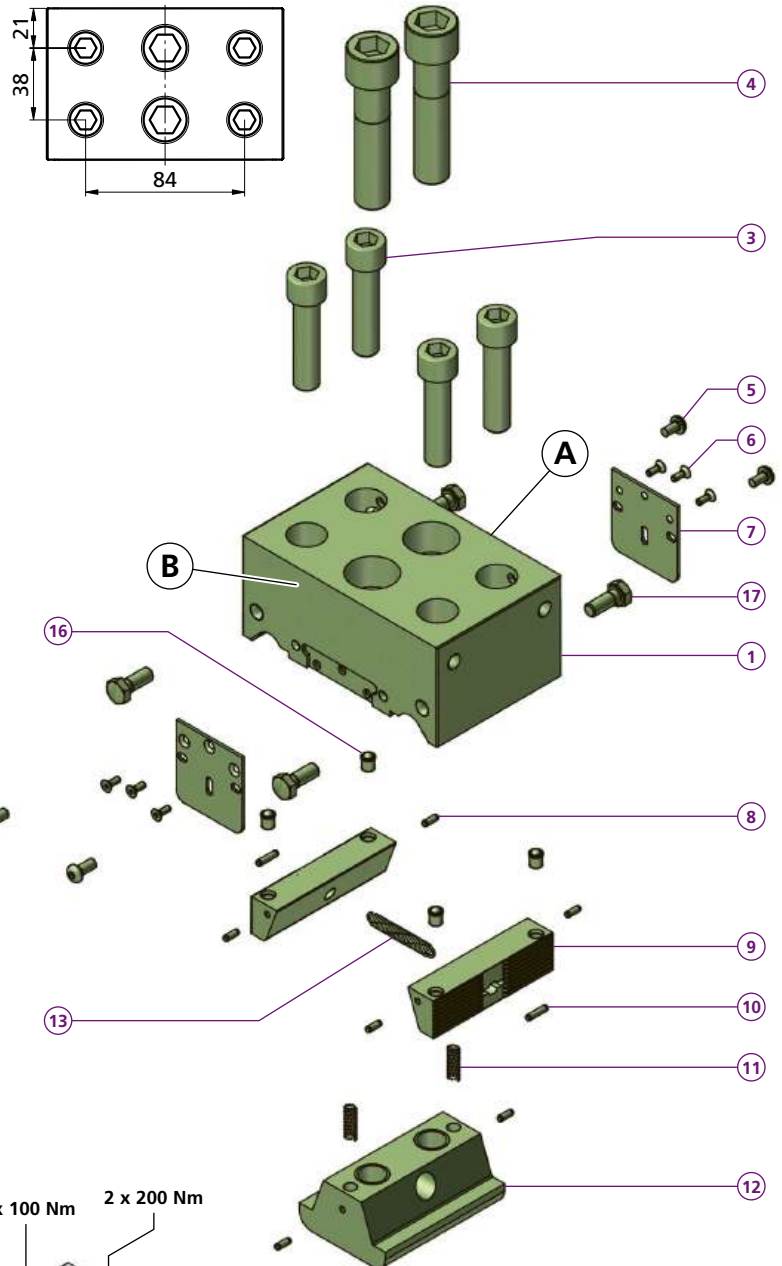
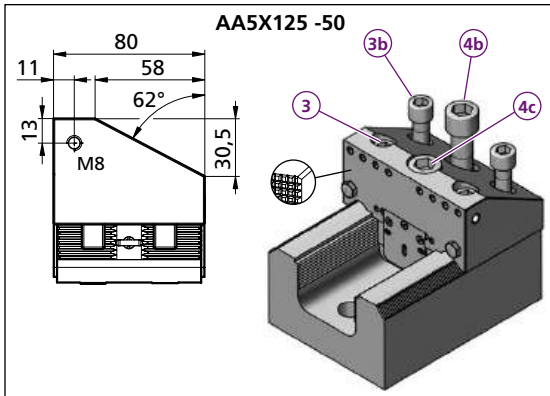
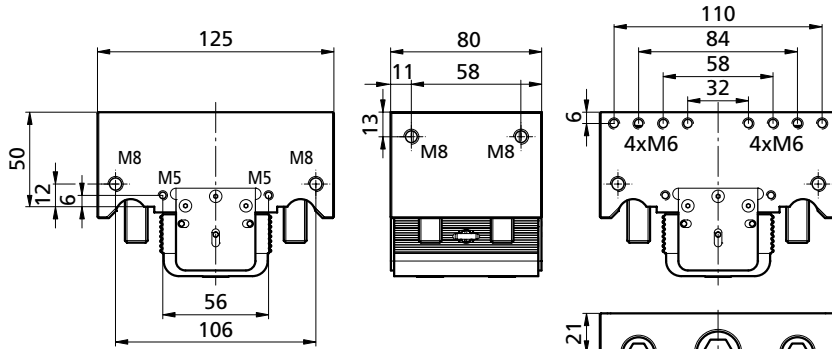

AAND125-50	
<b>1</b>	1x TF140692
<b>3</b>	4x M12X50ISO4762
<b>4</b>	2x M16X70ISO4762
<b>5</b>	4x M5X10ISO7380-1
<b>6</b>	6x M3X6DIN7991
<b>7</b>	2x ACBL4243
<b>8</b>	6x Ø 3x8 VSM 12785
<b>9</b>	2x ACSF7620
<b>10</b>	2x Ø 3h 8x12 ISO 2338
<b>11</b>	2x FED0618
<b>12</b>	1x ACSK7632M16
<b>13</b>	1x FED Ø 5,5x39
<b>16</b>	4x Ø 6-Niro SM1275-3
<b>17</b>	4x M8X16ISO4017
<b>kg</b>	~4,8

AA5X125-50	
<b>1</b>	1x TF140693
<b>3</b>	2x M12X50ISO4762
<b>3b</b>	2x M12X30ISO4762
<b>4c</b>	1x M16X65ISO4762
<b>4b</b>	1x M16X45ISO4762
<b>5</b>	2x M5X10ISO7380-1
<b>17</b>	2x M8X16ISO4017
<b>kg</b>	~4,6

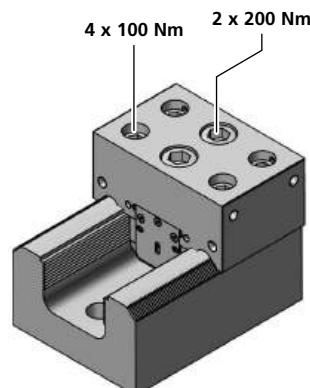

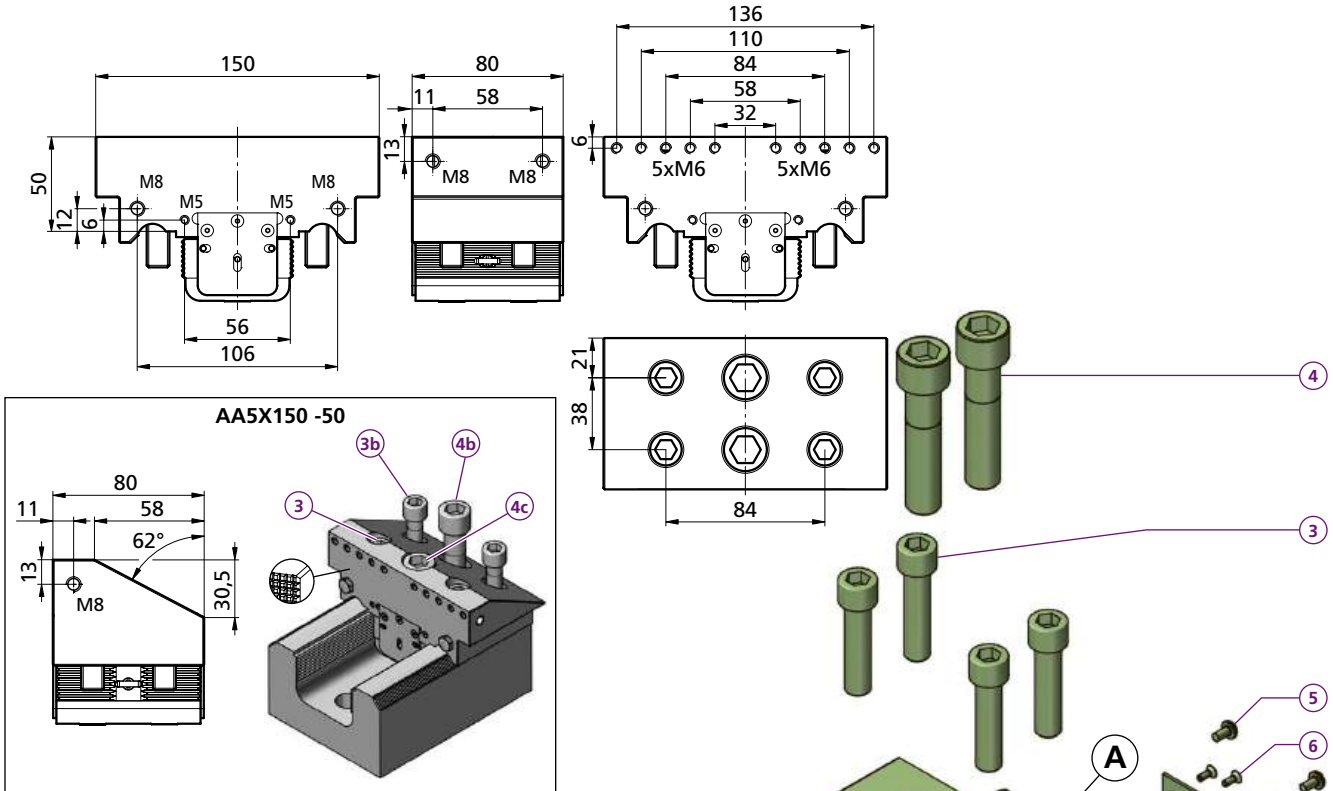

- AAND150-50**
- 1x TF140695
  - 4x M12X50ISO4762
  - 2x M16X70ISO4762
  - 4x M5X10ISO7380-1
  - 6x M3X6DIN7991
  - 2x ACBL4243
  - 6x Ø 3x8 VSM 12785
  - 2x ACS P7620
  - 2x Ø 3h 8x12 ISO 2338
  - 2x FED0618
  - 1x ACSK7632M16
  - 1x FED Ø 5,5x39
  - 4x Ø 6-Niro SM1275-3
  - 4x M8X16ISO4017
- kg ~5,2

- AA5X150-50**
- 1x TF140696
  - 2x M12X50ISO4762
  - 2x M12X30ISO4762
  - 1x M16X65ISO4762
  - 1x M16X45ISO4762
  - 2x M5X10ISO7380-1
  - 2x M8X16ISO4017
- kg ~5,0

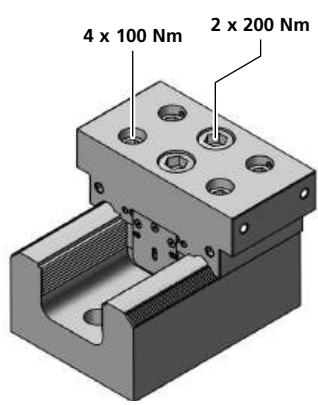

Bestellbeispiel / Ordering example: **AAND150-50**

AA5X125-50VB

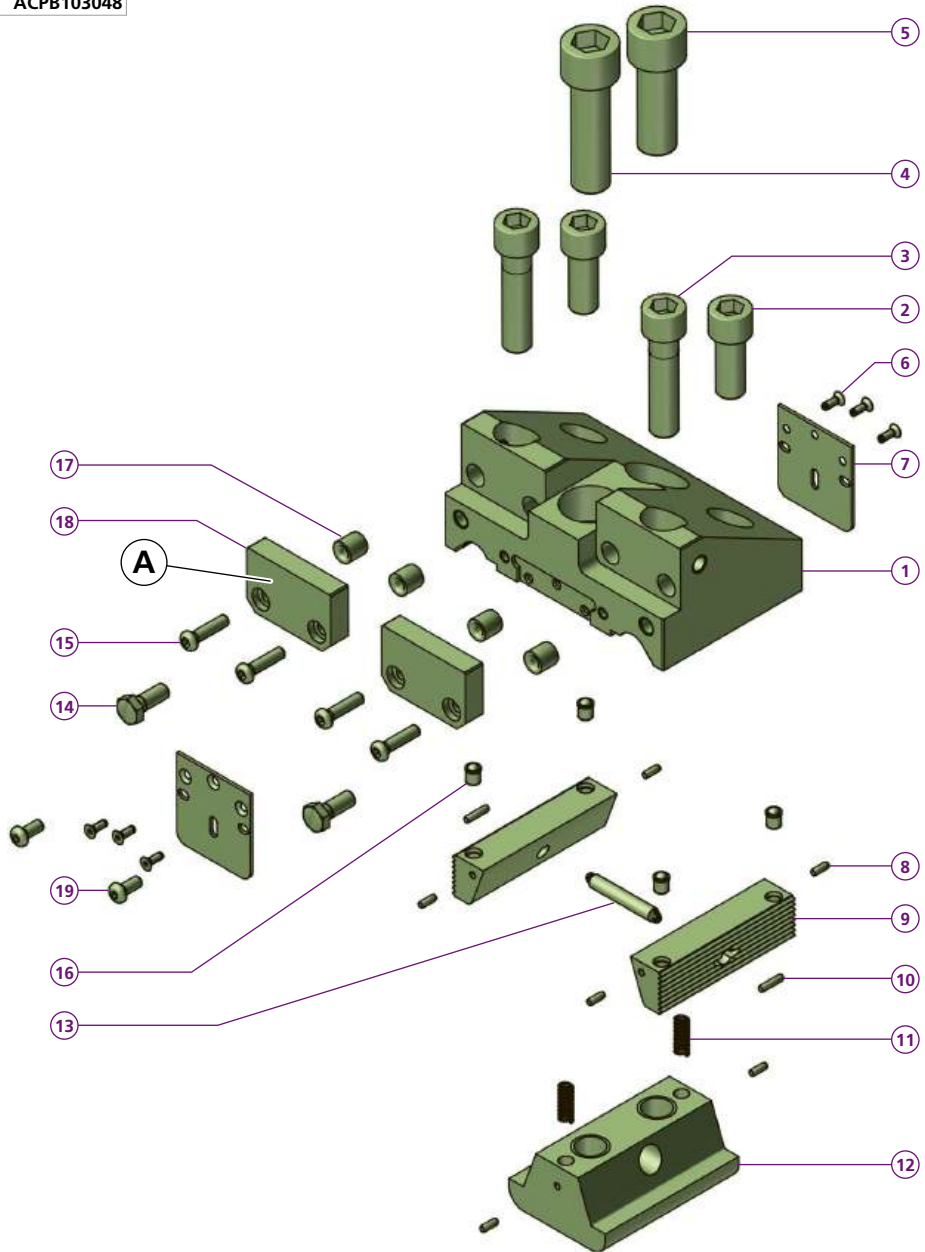
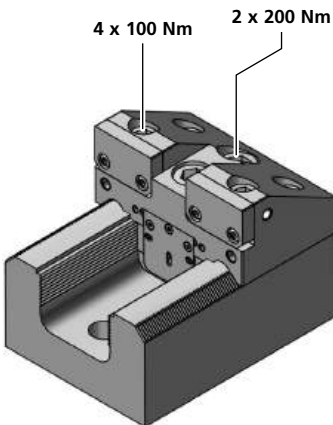
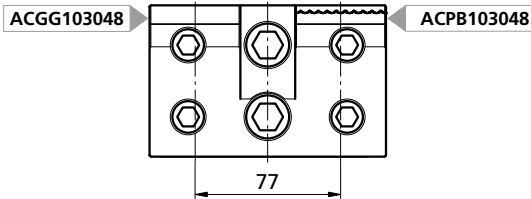
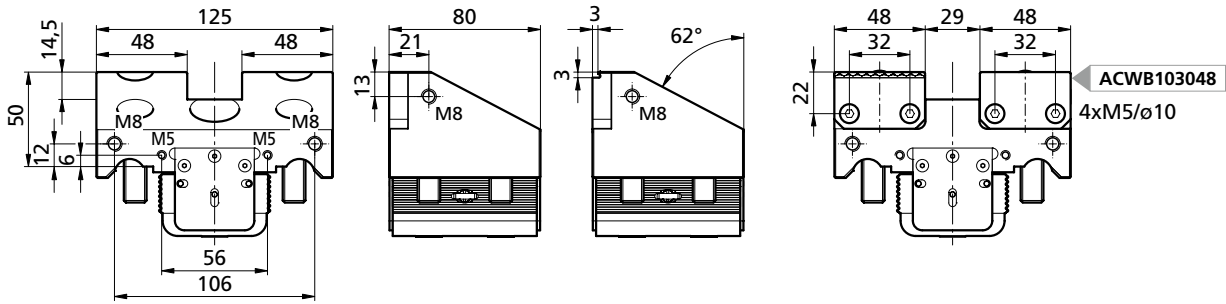

AA5X125-50VB	
1	1x TF140694
2	2x M12X30ISO4762
3	2x M12X50ISO4762
4	1x M16X55ISO4762
5	1x M16X45ISO4762
6	6x M3X6DIN7991
7	2x ACBL4243
8	6x Ø 3x8 VSM 12785
9	2x ACSF7620
10	2x Ø 3h 8x12 ISO 2338
11	2x FED0618
12	1x ACSK7632M16
13	1x FED Ø 5,5x39
14	2x M8X16ISO4017
15	4x M5X20ISO7380-1
16	4x Ø 6-Niro SM1275-3
17	4x 5,2x10x10 DIN179-A
18	2x
19	2x M5X10ISO7380-1
kg	~4,5

ACGGB103048	
*ACWB103048	
ACPB103048	
ACWB103048	
ACPB103048	

Bestellbeispiel / Ordering example:  
1x AA5X125-50VB & 2x ACGGB103048

Separat bestellen / Order separately

\* = weich / soft

**Parallelunterlage  
Steel parallels**

124mm	B	H	kg
ACU21124	124	21	~0,138
ACU36124	124	36	~0,250
ACU41124	124	41	~0,294
ACU46124	124	46	~0,328

94mm	B	H	kg
PCU14093	93	14	~0,04
PCU20093	93	20	~0,06
PCU24093	93	24	~0,07
PCU29093	93	29	~0,09
PCU31093	93	31	~0,09
PCU34093	93	34	~0,10
PCU39093	93	39	~0,11
PCU44093	93	44	~0,12
PCU46093	93	46	~0,14

125mm	B	H	kg
PCU20124	124	20	~0,08
PCU24124	124	24	~0,09
PCU29124	124	29	~0,11
PCU31124	124	31	~0,12
PCU34124	124	34	~0,13
PCU39124	124	39	~0,15
PCU44124	124	44	~0,17

**Universalnutstein  
Universal nut**

**ACES6540**

- ① 1x ACZS6540
- ② 1x ACEL6540
- ③ 1x M12X30DIN7984
- ④ 2x SM1275-1KSM8

kg ~ 0,67

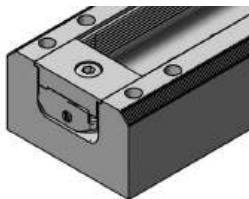

**ACES10240H07**

- ① 1x ACZS6540
- ② 1x ACEL6540-07102
- ③ 1x M12X30DIN7984
- ④ 2x SM1275-1KSM8

kg ~ 0,88



**ACES10040H25W**

- ① 1x ACZS6540
- ② 1x ACEL10040H25W
- ③ 1x M12X30DIN7984
- ④ 2x SM1275-1KSM8

kg ~ 1,42

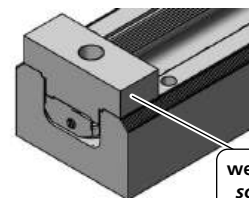

weich  
soft 1.2312

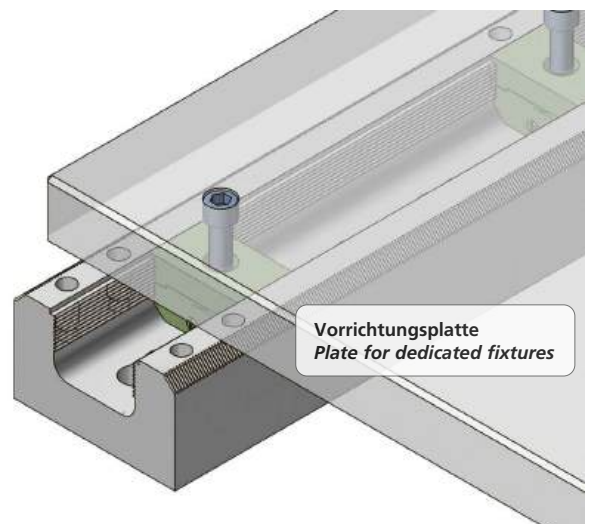

Bestellbeispiel / Ordering example: **ACES6540**

Separat bestellen / Order separately

# Universal - Unterlagenhalter

## Universal holder for steel parallels

**aptoCLAMP**

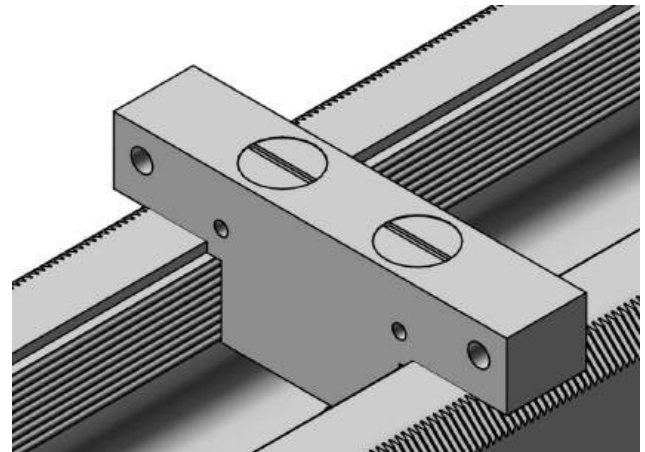
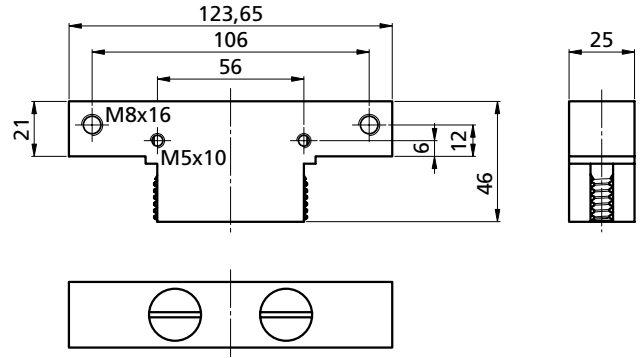
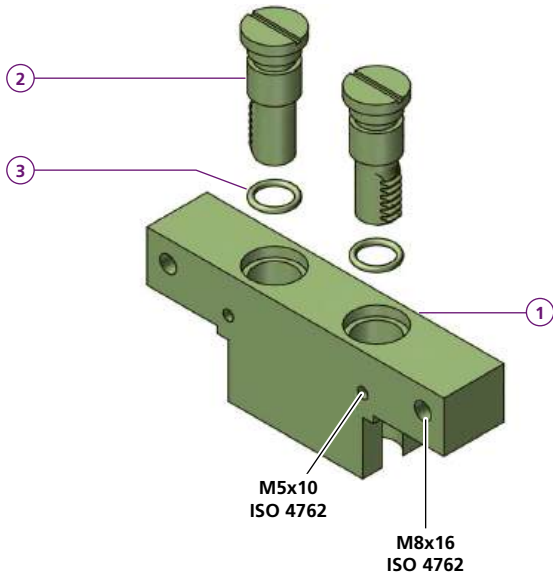

Bestellbeispiel / Ordering example: **ACUH21-124**

### ACUH21-124

- ① 1x TW090086-02
  - ② 2x ACBS1646
  - ③ 2x OR Ø 12X2
- kg ~ 0,74

### weiche Backe soft jaw

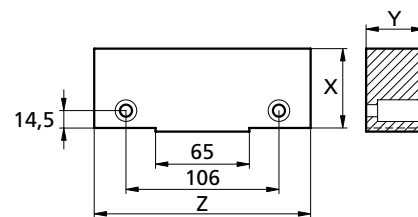
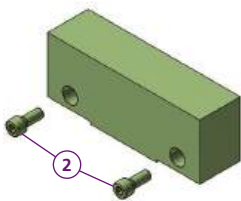

		X	Y	Z	kg
AC1505520W	②	55	20	150	~ 1,28
AC1505540W	M8X20ISO4762	55	40	150	~ 2,55

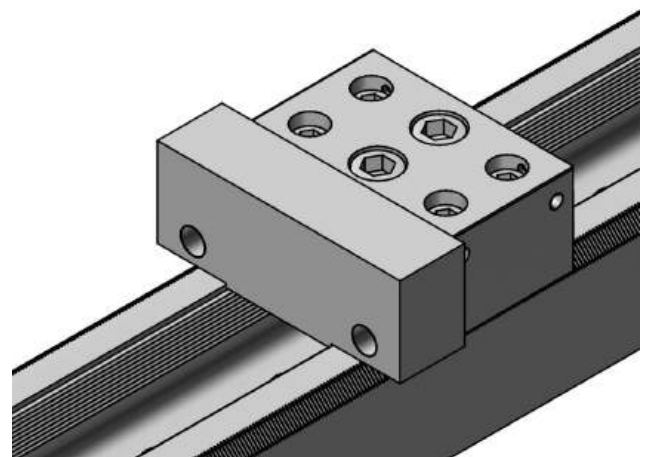

Bestellbeispiel / Ordering example: **AC1505520W**

Kunde Customer			
Maschine Machine		Werkstoff, Halbzeug, Rohteil-Nr., Modell- oder Gesenk-Nr. Raw material, blank or casting-Nr.	
X	Verfahrweg Traverse		mm
Y	Verfahrweg Traverse		mm
Z	Verfahrweg Traverse		mm
Z min.	kleinster Abstand von der Tischoberfläche zur Spindelnase smallest distance from table surface to spindle gauge line		mm
Z max.	grösster Abstand von der Tischoberfläche zur Spindelnase greatest distance from table surface to spindle gauge line		mm
Ø Spindel Spindle	Spindeldurchmesser Spindle diameter		mm
kg max.	Maximale Tischbelastung Maximum loading capacity		kg
A x B	Tischgrösse Size of the table		mm
E	T-Nuten Grösse T-slots size		mm
C	T-Nuten Abstand T-slots distance		mm
Rasterplatte Grid plate	H Raster Abstand Grid distance	mm	G Gewinde & Passungsdurchmesser Ø Thread & Precision Bohre
	Anzahl Werkstücke pro Los Number of workpieces per lot		Stück Pieces

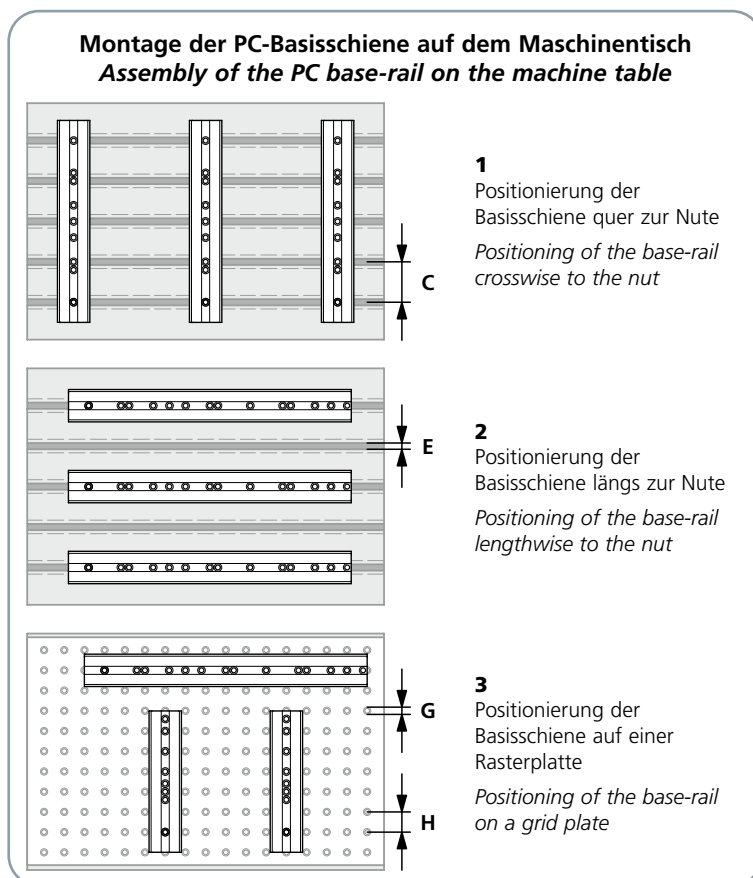
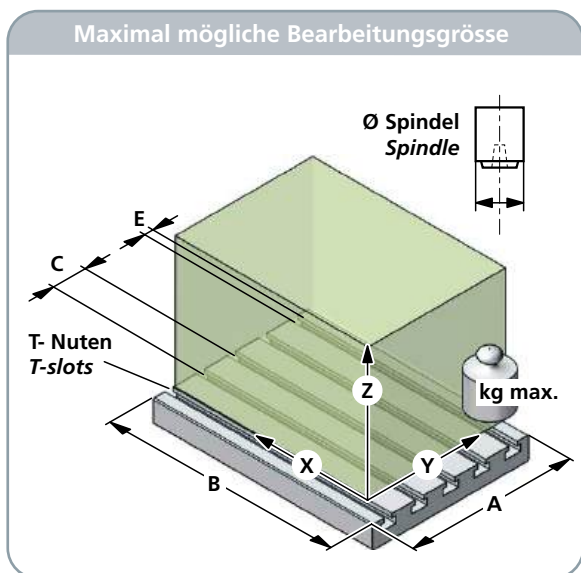





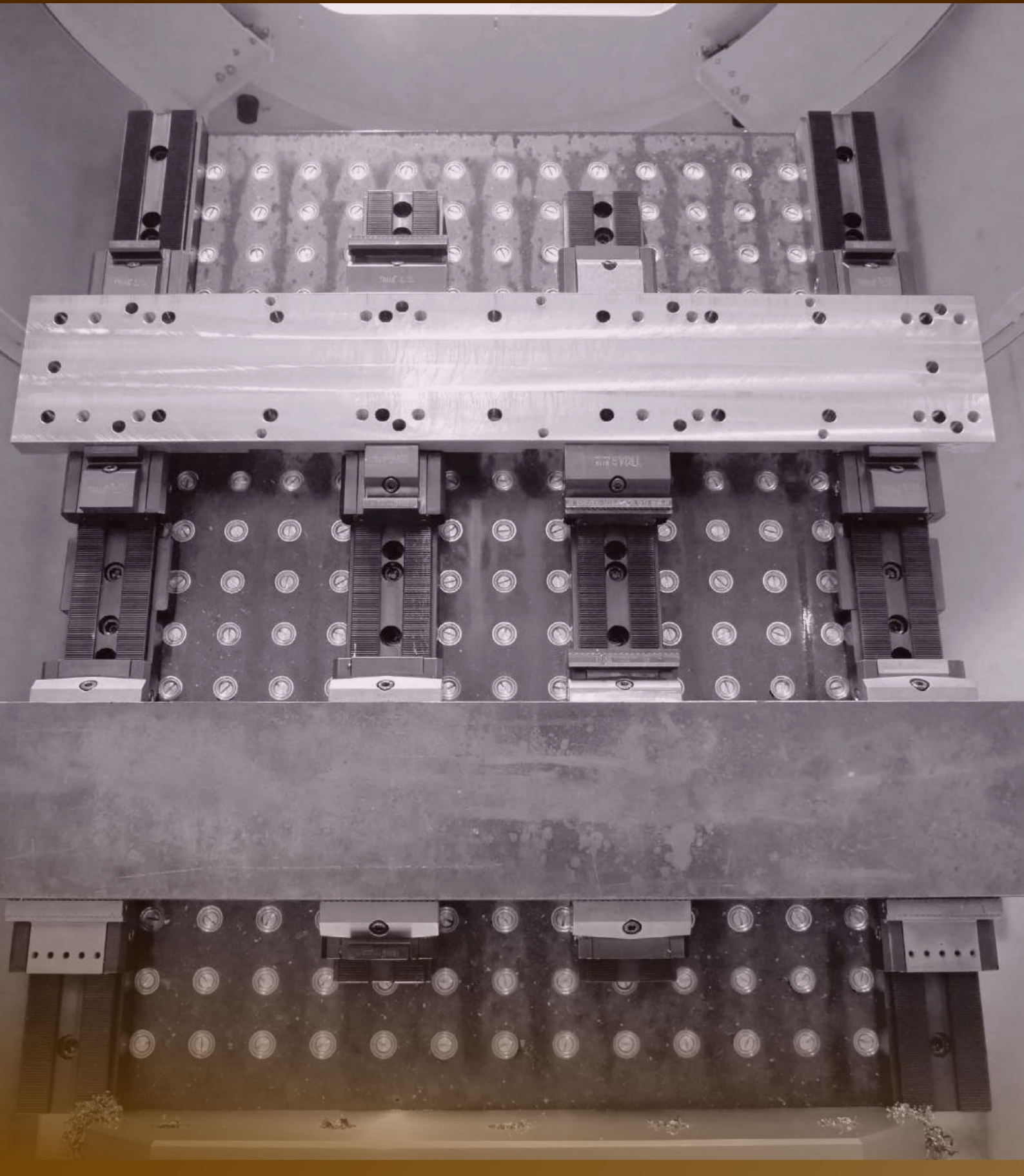

Bitte Werkstückzeichnung beilegen und Bearbeitungsfolge markieren  
Enclose drawing of workpiece and mark processing sequence, please

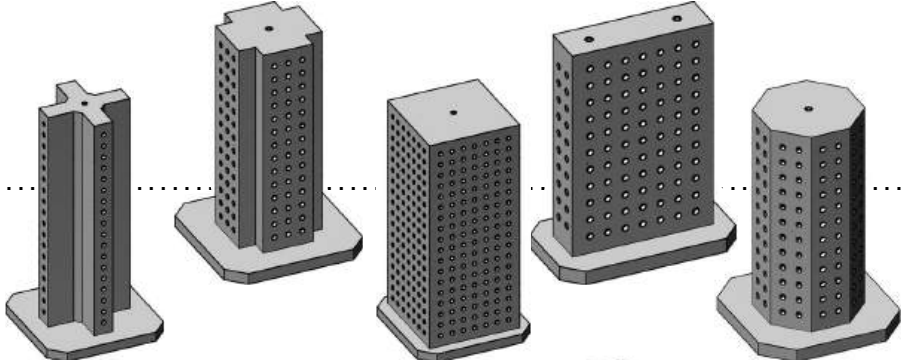

**tripoxy**MINERAL

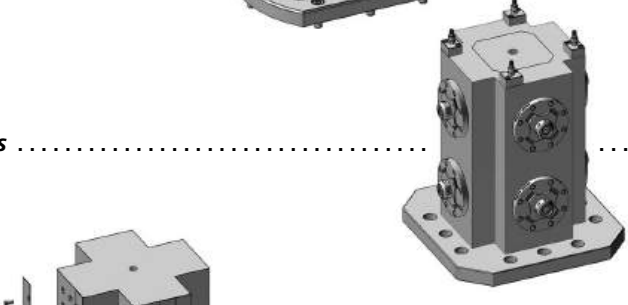
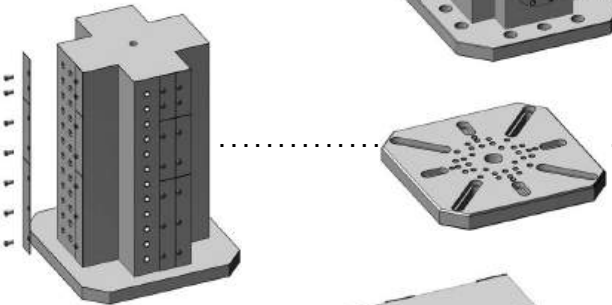
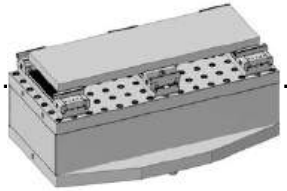

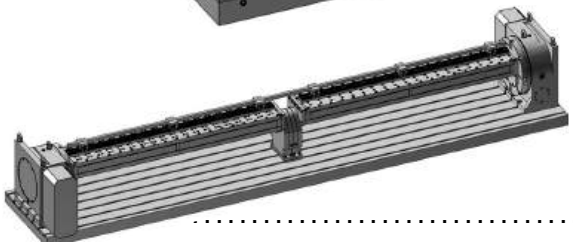
	Einleitung   <i>Introduction</i> .....	238 - 243	
	Bedienungsanleitung   <i>Operating manual</i> .....	244	
	Reparaturanleitung für Mineralguss   <i>How to repair epoxy mineral casting</i> .....	245	
	Anwendungsbeispiele   <i>Examples of application</i> .....	247 - 248	
		Mineralguss   <i>Epoxy mineral</i> .....	251
		Mineralgusserhöhung für 5-Achsenmaschinen <i>Epoxy mineral riser for 5-axis machines</i> .....	270
		Stahl Mineralguss   <i>Steel epoxy mineral tombstones</i> .....	271 - 272
		Zubehör   <i>Accessories</i> .....	273 - 274
		Stahl Mineralgusserhöhungen / <i>Steel-epoxy riser</i> .....	275
		Stahl Mineralgusserhöhungen mit integriertem Vakuum Anschluss <i>Steel-epoxy riser with integrated vacuum</i> .....	276
		Balken und Würfel aus Stahl-Mineralguss <i>Trunion and cubes made from steel epoxy</i> .....	277

Es ist ein Versprechen!  
Unsere Mineralgusstürme stehen gerade!

*It's a promise!  
Our epoxy tomb stones stand upright!*

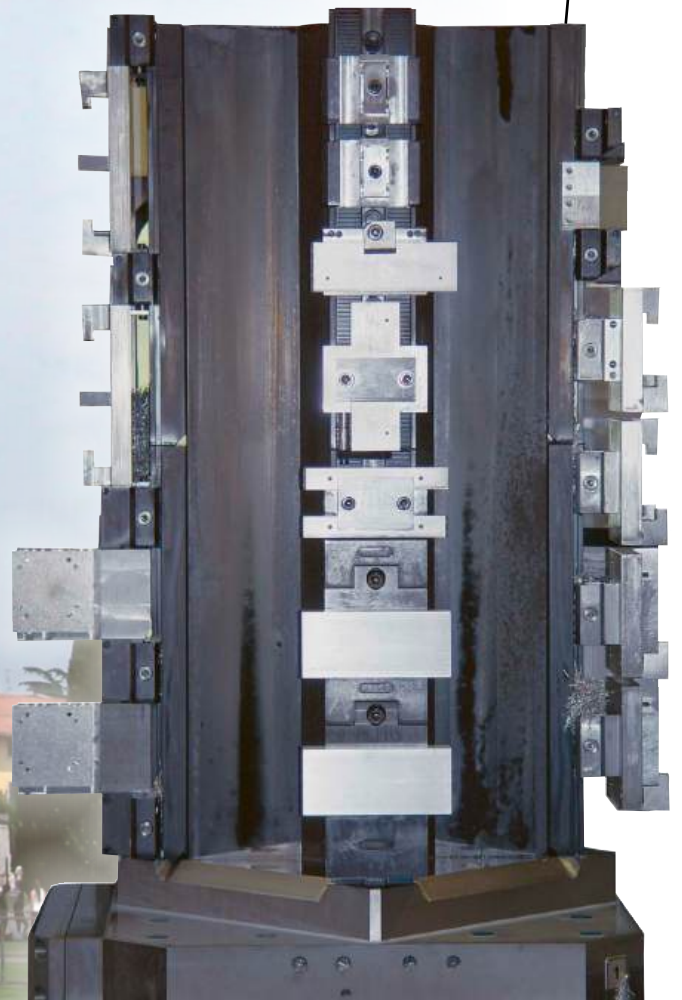

#### Maschinenschonend und leicht, in fast allen Formen herstellbar

Bei den immer schneller werdenden Horizontalbearbeitungszentren ist Gewichtsreduktion der Zuladung ein wichtiger Faktor. Unsere Spanntürme aus Mineralguss haben ein kleineres spezifisches Gewicht als Alu.

Zudem werden Vibrationen derart reduziert, dass auch bei einer Bearbeitung im oberen Turmbereich präzise bearbeitet werden kann. In gewissen Fällen, z.B. bei Werkstückspannungen (ohne Basisschienen) direkt auf den Turm, kann auch ein stahlummantelter Mineralgussturm eine Ergänzung sein.

#### Reduces machine wear due to low specific weight - can be produced in all sorts of shapes

As the rapid traverse on modern horizontal machining centres is constantly increasing, the weight of the payload becomes obviously an important point. Our tombstones made of epoxy mineral casting are lighter in their specific weight than aluminium.

In addition, vibrations are greatly reduced in a way that even in the upper end of the tombstone high accuracy is guaranteed. In certain cases, as for instance when the fixture is designed without the base rail, that means directly mounted on the cube, the tombstone can be improved by a steel jacket.

- Leicht und stabil
- Vibrationsdämpfung 10 x besser als Grauguss und 100 x besser als Alu!
- Spezifisches Gewicht leichter als Aluminium
- Seitenflächen geschliffen mit Bohrungen (M12 / 12F7)
- Grundplatten nach Maschinenspezifikation
- Andere Formen auf Anfrage

- *Lightweight and rigid*
- *Damping effect 10 x better than cast iron 100 x better than alu!*
- *Specific weight lighter than aluminum*
- *Faces ground, hardened bushings (M12/12F7)*
- *Base plate made to machine specifications*
- *Other dimensions on request*

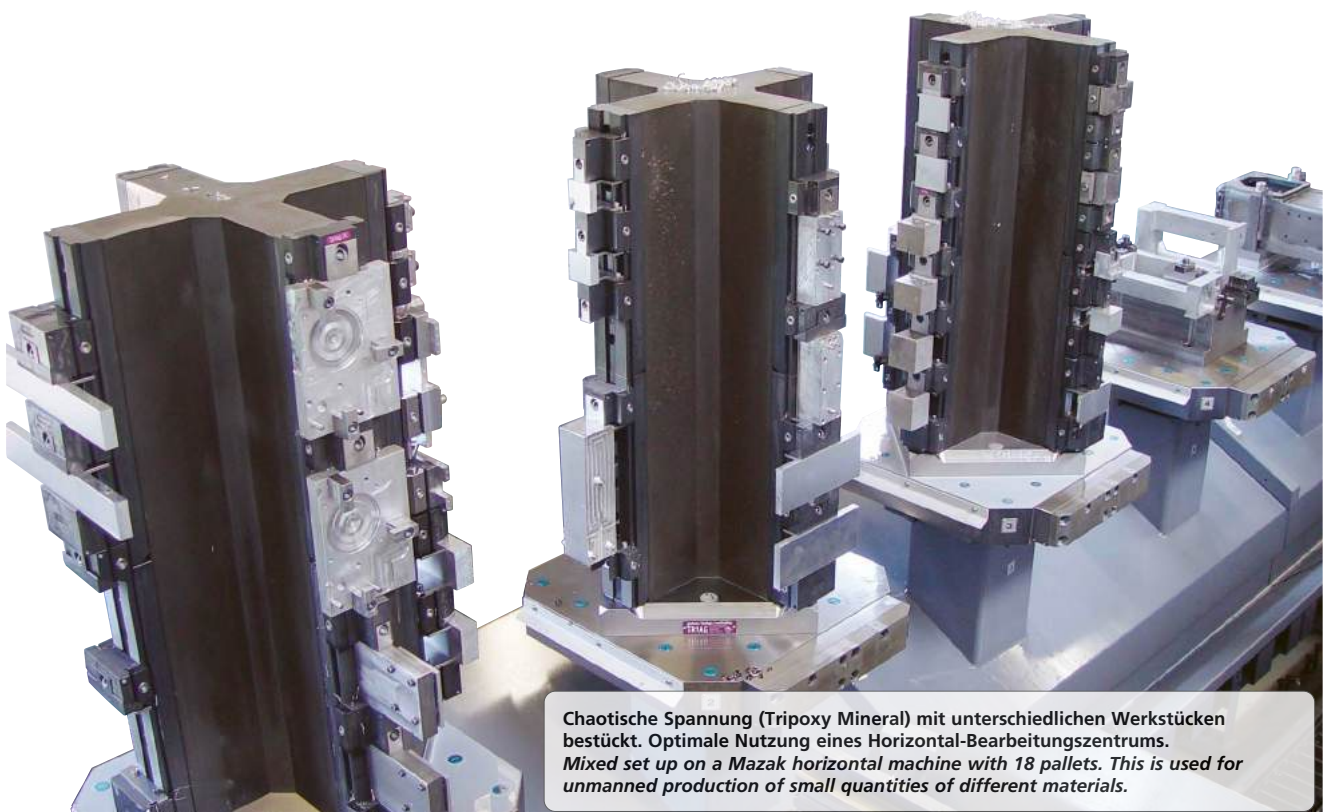

Chaotische Spannung (Tripoxy Mineral) mit unterschiedlichen Werkstücken bestückt. Optimale Nutzung eines Horizontal-Bearbeitungszentrums. Mixed set up on a Mazak horizontal machine with 18 pallets. This is used for unmanned production of small quantities of different materials.

Mineralguss (auch Polymerbeton genannt) ist ein Kunststein, bestehend aus Quarzkies, Quarzsand und Gesteinsmehl. Als Binder dient ein hochwertiger Epoxidharz. Das gemischte Material wird in Giessformen gefüllt.

Während dem Giessprozess wird die Form, mittels Vibrations-tisch ständig vibriert, was zur Verdichtung und Entlüftung der Giessmasse führt. Das spezifische Gewicht ist mit 2,4 kg / dm<sup>3</sup> geringer als das von Aluminium und die Vibrationsdämpfung ist 10 mal besser als bei Grauguss, 100 mal besser als Aluminium. Neben den guten Dämpfungseigenschaften ist auch die Temperaturstabilität (geringe Wärmeleitfähigkeit und hohe Wärmekapazität) zu erwähnen.

Das Material ist ausserdem chemisch beständig gegen Öle, Laugen, Säuren und die üblichen Kühlschmierstoffe. Im ausgegossenen Zustand sind die Türme «Umweltneutral».

*Mineral casting (also called polymer concrete) is a stone composed of quartz gravel, silica sand and crushed rock. The binder is a high quality epoxy resin. The mixed material is filled into molds.*

*During the casting process, the form, constantly vibrating. Is resulting in the compaction and extraction of the casting mass. The specific weight is 2,4 kg / dm<sup>3</sup> is lower than that of aluminum, and the vibration attenuation is 10 times better than that of cast iron 100 times better than alu. Besides the good damping properties, the temperature stability is to be mentioned (low thermal conductivity and high heat capacity).*

*The material is also chemically resistant to oils, alkalis, acids and the usual cooling lubricants.*

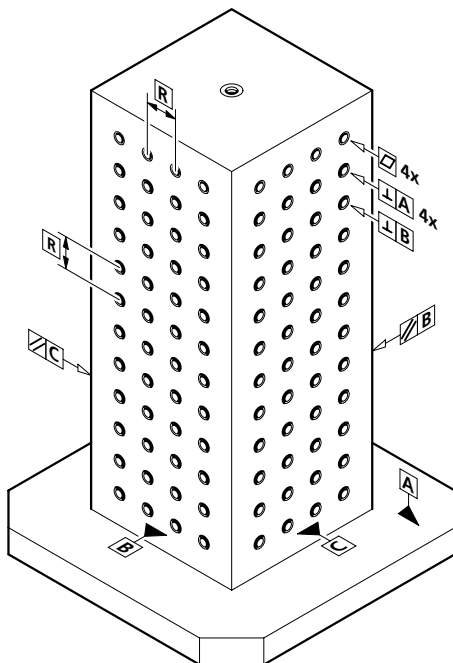

Eigenschaften Caractéristiques	Mineralguss Epoxy mineral	GG20	hochfestes Alu high density Alu
Dichte / Density [kg/dm <sup>3</sup> ]	ca. 2,4	ca. 7,1-7,3	ca. 2,76
Logarithmisches Dekrement grösser als (Vibrationsdämpfung) Logarithmic Decrement (damping)	0,035	0,004	0,0004
Längenausdehnungs-koeffizient Coefficient of linear expansion [1/K]	ca. 12x10 <sup>-6</sup>	ca. 10x10 <sup>-6</sup>	ca. 23x10 <sup>-6</sup>
Zugfestigkeit / Tensile strength [N/mm <sup>2</sup> ]	15 - 20	200 - 400	470 - 520
Wärmeleitfähigkeit Thermal conductivity [W/mK]	ca. 2	ca. 50	ca. 140

Lagetoleranz der Rasterbohrungen Positioning tolerance of the holes	<b>R</b>	<b>0 - 500 mm ± 0,01</b> <b>501 - 1000 mm ± 0,02</b>
Ebenheit Flatness		<b>0,01 mm / 300 mm</b>
Parallelität Parallelism		<b>0,01 mm / 300 mm</b>
Winkligkeit Deviation of angle		<b>0,01 mm / 200 mm</b>

### Mineralguss wird unter anderem für folgende Anwendungen eingesetzt: Cast mineral is among other things the following Applications used:

- ➔ Maschinenbetten  
Machine beds
- ➔ Maschinenständer und -portale  
Machine column and portals
- ➔ Als Alternative zu Grauguss (Kosten, Umweltfreundlichkeit)  
As an alternative to cast iron (cost, environmental friendliness)
- ➔ Als Alternative zu Schweisskonstruktionen  
As an alternative to welded constructions
- ➔ Als Alternative zu Natursteinanwendungen (z.B. Messtische, Reinraumtechnologie)  
As an alternative to natural stone applications (eg, measuring tables, clean room technology)
- ➔ Generell steifigkeits- und festigkeitsdimensionierte Strukturbauteile  
General stiffness and strength-scale structural components
- ➔ Integrierte Funktionalität möglich (Schläuche, Ventile, Elektrik, Lastanker etc.), auch nachträgliches Eingiessen möglich  
Integrated functionality possible (hoses, valves, electrical, anchor load, etc.), and subsequent pouring possible
- ➔ Füllung von Mineralguss in Blechmantelkonstruktionen (z.B. unsere Stahl-Mineralguss-Basissschienen)  
Filling of mineral cast in metal shell constructions (eg, our steel rails with epoxy mineral cast base)

**tripoxyMINERAL**

Die Gewichtsreduktion der Zuladung ist bei den immer schneller werdenden Horizontalbearbeitungszentren ein wichtiger Faktor. Die Spanntürme aus Mineralguss haben ein kleineres spezifisches Gewicht als Aluminium. Diese verfügen über eine so hohe Vibrationsdämpfung, dass dadurch im oberen Bereich der Türme sehr präzise gearbeitet werden kann und dabei exzellente Oberflächengüten erreicht werden.

Seit Jahren bietet die Triag International AG aus eigener Produktion mit den Tripoxy Mineral-Spanntürmen eine sehr gute Alternative zu Spanntürmen aus anderen Materialien (z.B. Grauguss- oder Aluminium) an.

*The weight reduction of the load is an important factor in the increasingly rapid horizontal machining centers. The tombstones of mineral casting have a lower specific weight than aluminum. Another big advantage is the vibration clamping which helps to achieve excellent surfaces on your workpieces, even on top of your tombstone. Beside that there are another two good reasons for epoxy mineral tombstones. One is the materials is not getting rusty and the slow thermal expansion.*

*For years, the Triag International AG offers its own production with the Tripoxy mineral tombstones, a very good alternative to tombstones made of other materials (such as cast iron or aluminum) to.*

**Mineralgusstürme samt  
 Spansystem aus einer Hand!**

**Epoxy mineral tombstones including  
 clamping system from one source!**

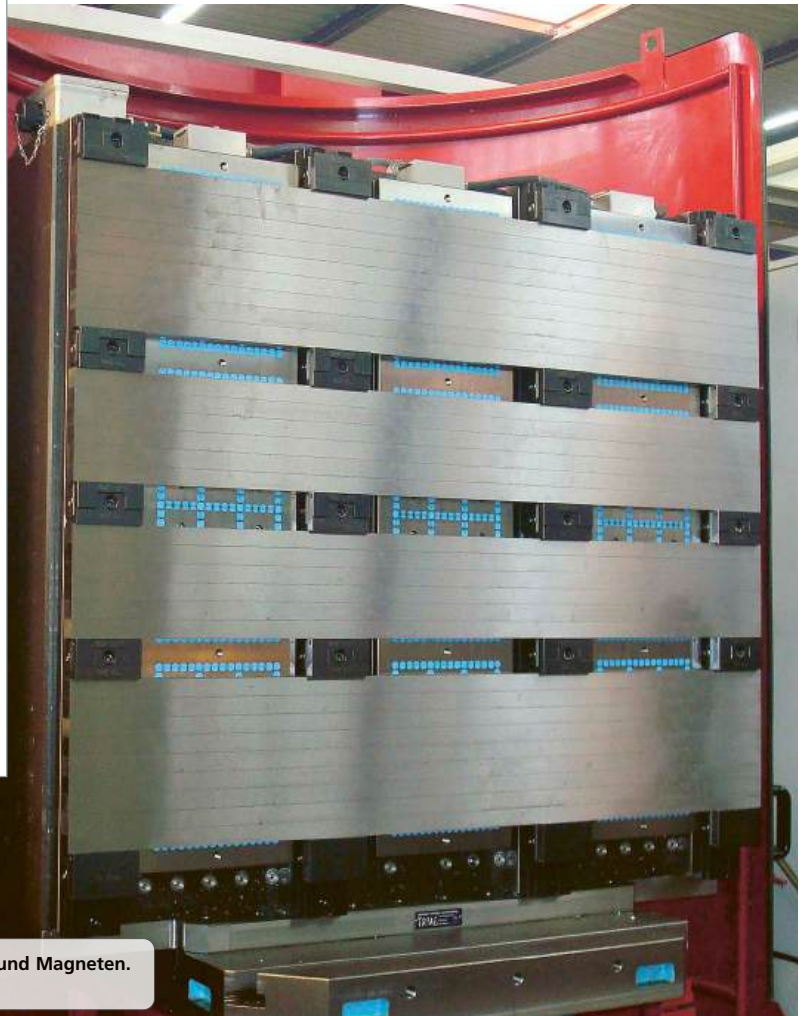

Mineralgussturm kombiniert bestückt mit Power Clamp und Magneten.  
 Epoxy cube equipped with magnet and Power Clamp



Grosse Platte auf einem rechteckigen Mineralgussturm.  
 Large plates on epoxy tombstone.



Chaotische Fertigung auf einem Mineralgussturm in Kreuzform.  
 Mixed set up on cross epoxy tombstone.



Spezielle Vorrichtung mit Micro Clamp Modulen auf einem Mineralgussturm.  
 Dedicated fixture on epoxy tombstone

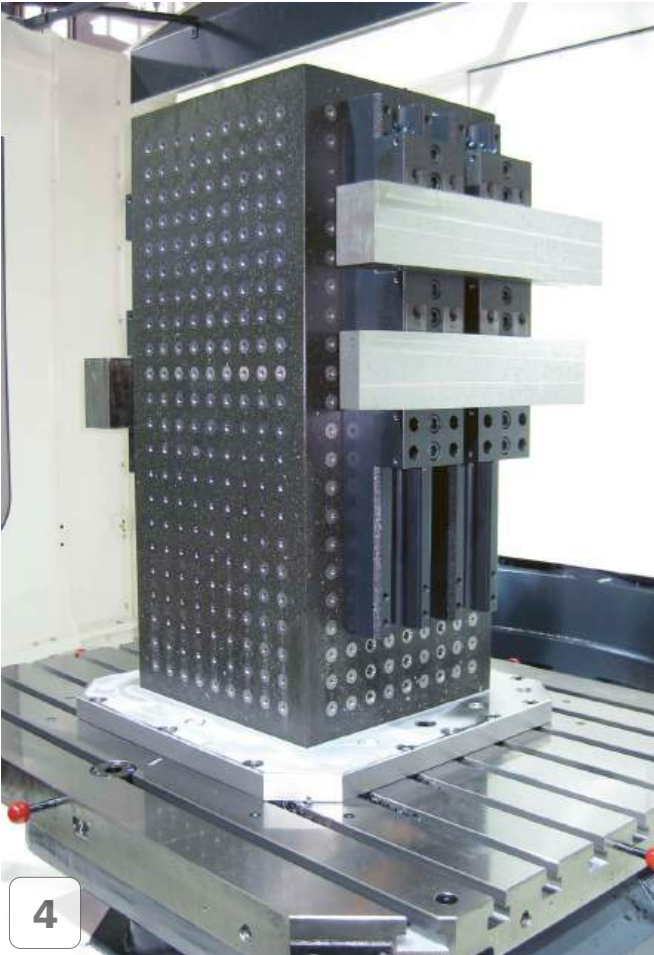

Linear stamping

# Stahl-Mineralguss

## Steel-epoxy mineral tombstones

**tripoxyMINERAL**

### Stahl-Mineralguss seit 2004 - das ideale Material für Spanntürme

Die Firma Triag International AG hat seit 2004 diese stahlummantelten Türme mit sehr guten Ergebnissen bei Kunden im Einsatz. In den meisten Fällen können optimale Lösungen durch Standardangebote kostengünstig und modular eingerichtet werden.

### Steel-epoxy combinations since 2004 - the ideal material for tombstones and ricer cubes

Triag International AG customers are employing successfully tombstones with steel jackets since 2004. In most cases optimal solutions can be found with standard Triag clamping devices.

Stahl-Mineralguss für die perfekte Vibrationsdämpfung  
Steel epoxy tombstone for perfect vibration dampening

Max. Palettenzuladung auf Mazak H BZ  
Max pallet load on this Mazak application = 600kg H = 800

Komplettes Gewicht 600 kg inkl. Werkstücke WS = 8 x 38 kg  
Complete load weighs 600 kg incl-parts

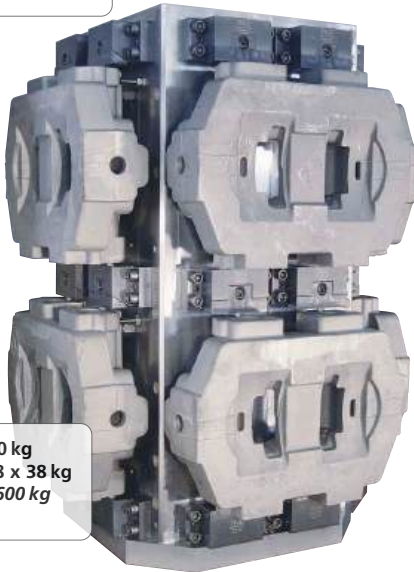

200 x 400 x 1330

Flügelteil für Airbus A320  
Tail wing part for Airbus A320

Stahlmineralguss-Säulen mit Power Clamp für die Fertigung von Flügelteilen.  
Steel epoxy frames machining wing parts on a Makino machine

Stahl-Mineralguss Dreieck-Turm  
Steel epoxy triangle cube



Stahl-Mineralguss Pyramide  
Steel epoxy pyramid stomp



Stahlmineralgussturm mit Power Clamp zum Leistungsfräsen in Werkzeugstahl (unbemannt).  
Steel epoxy tombstone with Power Clamp 10 pcs of tool steel are machined (running time 5,3 hours)

**Es gibt eine Vielzahl von Standardformen**

***There are a variety of standard forms***

***tripoxyMINERAL***

**Die Mineralgusstürme können in fast allen**

***The epoxy mineral tombstones can be manu-***  
***factured in almost any shape.***

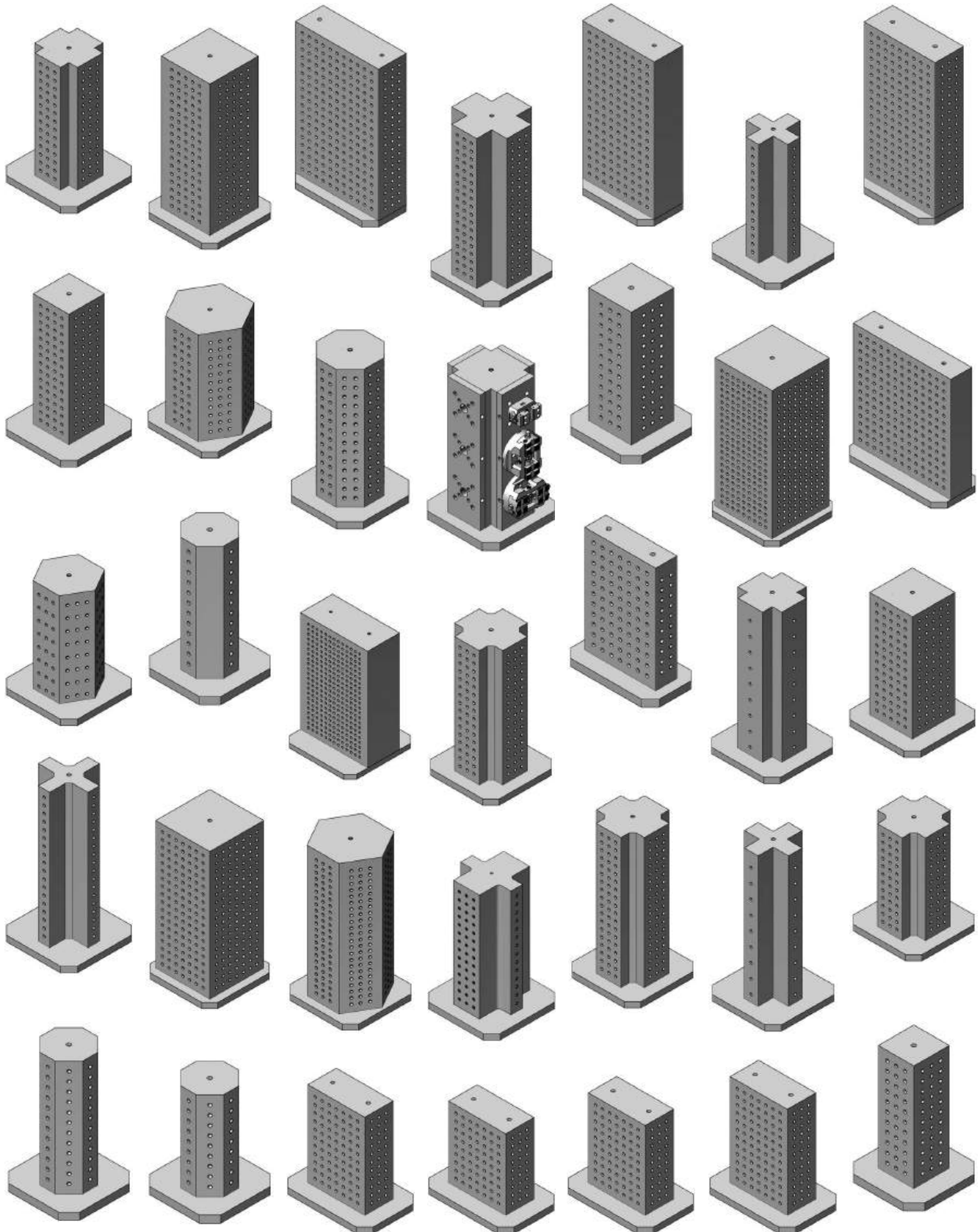

*Andere Größen, Formen und Raster, welche nicht im Katalog sind, können nach Kundenwunsch produziert werden.*  
*Other sizes, forms and grid which are not in the catalogue can be produced on customer's request.*

**ACHTUNG / CAUTION**

**Bevor Mineralgusstürme eingesetzt werden, beachten Sie bitte die folgenden Punkte!** *Prior to inserting the tombstones please note the following points!*

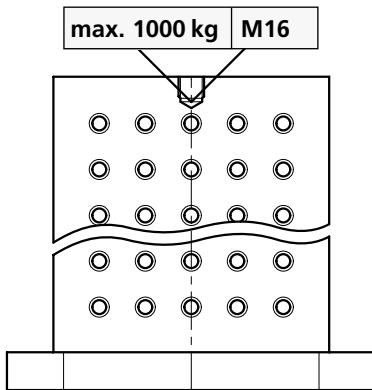

Höchstlast des angehängten Stücks / Maximum load of the affixed piece		
Drahtseil Steel rope	Bei fest angezogener Schraube For tightened screw	Bei zwei Schrauben insgesamt For two tightened screws
MRD 12 = 500 kg MRD 16 = 1000 kg	M12 = 340 kg M16 = 700 kg (DIN 580)	M12 = 240 kg M16 = 500 kg (DIN 580)

Bitte beachten Sie, dass die meisten Ringschrauben eine maximale Last haben von: **M12: 340 kg / M16: 700 kg** auch muss die Ringschraube bis zum Anschlag eingedreht sein!

*Please note that most of the lifting screws have a maximum load of: **M12: 340 kg / M16: 700 kg** It is also important that the lifting screw is driven into the socket!*

**Oberflächenabnutzung**

Durch schnelle, auf die Turmoberfläche schlagende Späne, sowie durch Hochdruckkühlung, die direkt auf den Turm spritzt, kann die Oberfläche des Mineralgussturmes beschädigt werden!

**Surface wear**

*The surface of the tombstone can be seriously damaged by chips hitting the tombstone quickly as well as by high pressure cooling water splashing directly onto the tombstone!*

**Massnahmen:**

Dort wo lange Späne oder auch kurze abrasive Späne auf den Turm schlagen, Abdeckbleche benutzen! (Abdeckbleche siehe Seite 244)

**Measure:**

*Use cover sheets wherever long or short abrasive chips hit the tombstone! (Cover sheets page 244)*

**Achtung Grenzfälle**

Folgende Anwendungen können nur bedingt eingesetzt werden, da eine einzelne Schraube auf Zug ohne Gegenlast die eingegossene Buchse belastet!

**Attention, limited application**

*The following applications only have limited use as a single screw without a counterweight puts tremendous tension on the integral socket!*



**Max. Anzugsmomente beachten.**

**Note max. starting torques.**

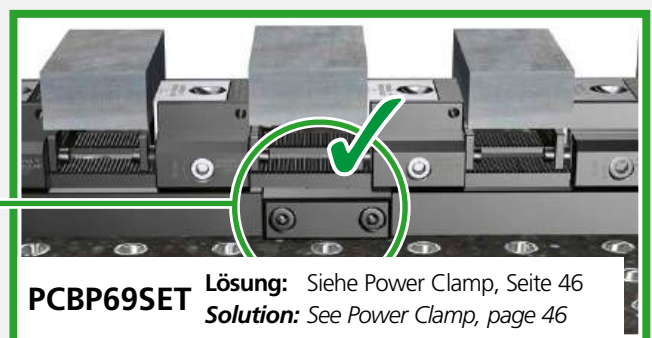
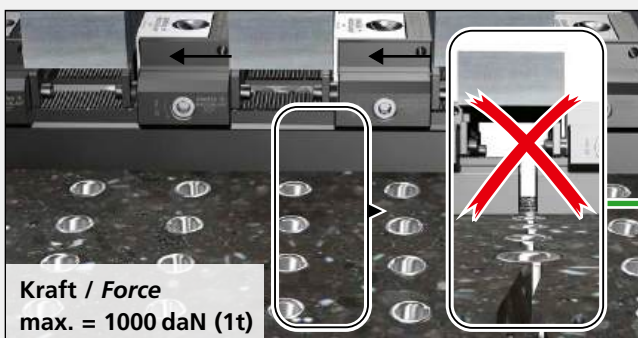
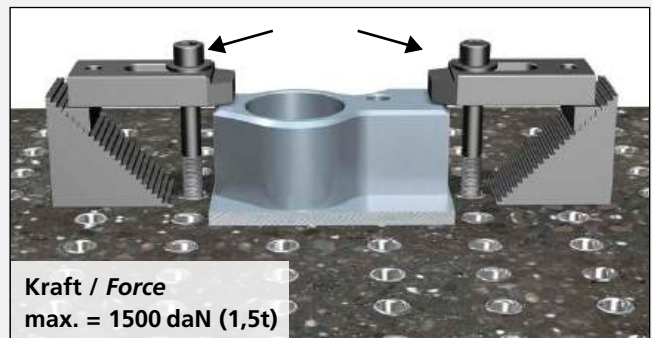
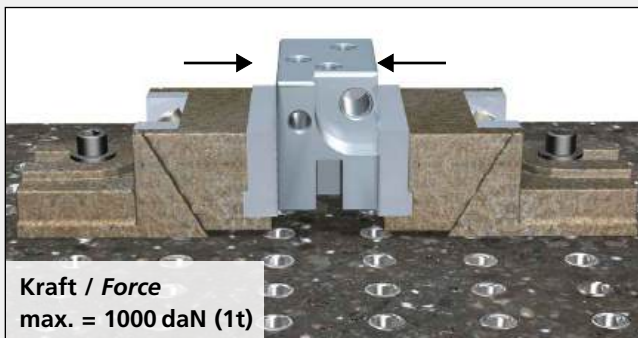

#### Bruchstelle

Bruchstelle des Mineralgussturmes mit Aceton reinigen, danach mit Metallplatte und Schraubzwinde einschalen. Bei grossen Reparaturen sollte die Platte zusätzlich mit Hartwachs (Bild 6) eingerieben, poliert und nachträglich mit Silikon abgedichtet werden. (Siehe Bilder 1-4)

#### Mineralgussreparaturset (Bild 5)

##### MREP-SET 0300 ~ 300 gr = ~ 2 dl

Das Reparaturset setzt sich aus dem Harz, Härter und Füller zusammen. Das Mischverhältnis ist: auf 27 gr Härter kommt 100 gr Harz und 150 gr Füller.

#### Das Verhältnis ist genau abgewogen. Wichtig ganze angelieferte Menge gebrauchen.

Harz und Härter zusammengiessen und intensiv 2 Min. rühren. Das Durchmischen der Masse ist entscheidend für das optimale Abbinden des Mineralgusses. **Danach Füller dazugeben und das gleiche nochmals 2 Min.** lang untereinander mischen bis eine gipsähnliche Masse entsteht.

Die flüssige Masse wird nun in die Bruchstelle eingegossen.

Das Aushärten der Reparaturmasse beträgt 24 Std. Die Unebenheit der frisch eingegossenen Fläche, wird mit einem Schleifstein plangeschliffen.

#### Point of rupture

Clean the section of fracture with Acetone, then press metal plates with screw clamps onto the point of damage. If the damage is a major one the metal plates must be waxed first (picture No. 6) and sealed with Silicon if necessary (pls. note pictures 1 to 4)

#### Repair kit for epoxy mineral castings (picture 5)

##### MREP-SET 0300 ~ 300 gr = ~ 2 dl

The repair kit consists of the resin, the hardener, and the filler. The mixture ratio is: 27 gr of hardener, 100 gr of resin and 150 gr of filler.

#### These components are exactly portioned in the kit and should be used up entirely.

The resin and the hardener should be poured together and mixed for 2 min. This mixing process is essential for a good bonding with the mineral casting. **Then the filler should be added while mixing the mass another 2 min.** It will reach a consistency like plaster.

This mortar must be poured into the point of rupture.

The hardening process takes 24 hours. Protruding material can be levelled with a grindstone.

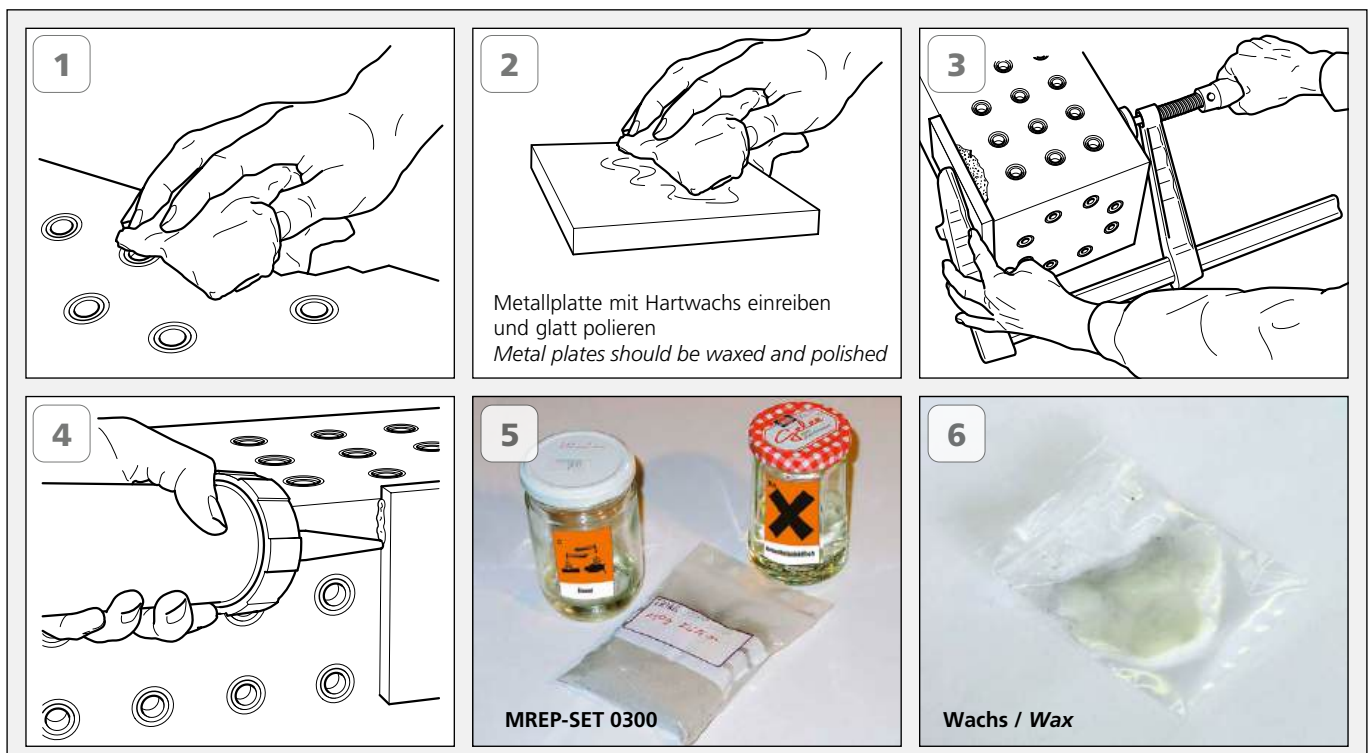

<b>Kunde</b> <i>Customer</i>			
<b>Maschine</b> <i>Machine</i>		Werkstoff, Halbzeug, Rohteil-Nr., Modell- oder Gesenk-Nr. <i>Raw material, blank or casting-Nr.</i>	
<b>X max.</b>	X Achse Hub <i>X axis stroke</i>		<b>mm</b>
<b>Y min.</b>	Kleinsten Abstand von der Palettenoberseite zur Spindelachse <i>Smallest distance from pallet surface to spindle center</i>		<b>mm</b>
<b>Y max.</b>	Grösster Abstand von der Palettenoberseite zur Spindelachse <i>Greatest distance from pallet surface to spindle center</i>		<b>mm</b>
<b>Z min.</b>	Kleinsten Abstand von der Palettenachse zur Spindel Nase <i>Smallest distance from pallet center to spindle gauge line</i>		<b>mm</b>
<b>Z max.</b>	Grösster Abstand von der Palettenachse zur Spindel Nase <i>Greatest distance from pallet center to spindle gauge line</i>		<b>mm</b>
<b>∅ Spindel</b> <i>Spindle</i>	Spindeldurchmesser <i>Spindle diameter</i>		<b>mm</b>
<b>kg max.</b>	Maximale Tischbelastung <i>Maximum loading capacity</i>		<b>kg</b>
<b>∅D max.</b>	Maximaler Störkreis des Werkstücks <i>Maximum workpiece diameter</i>		<b>mm</b>
<b>H max.</b>	Maximale Beladehöhe des Werkstücks <i>Maximum workpiece height</i>		<b>mm</b>
<b>A x B</b>	Palettenabmessung <i>Size of pallet</i>		<b>mm</b>
	Anzahl Werkstücke pro Los <i>Number of workpieces per lot</i>		<b>Stück</b> <i>Piece</i>

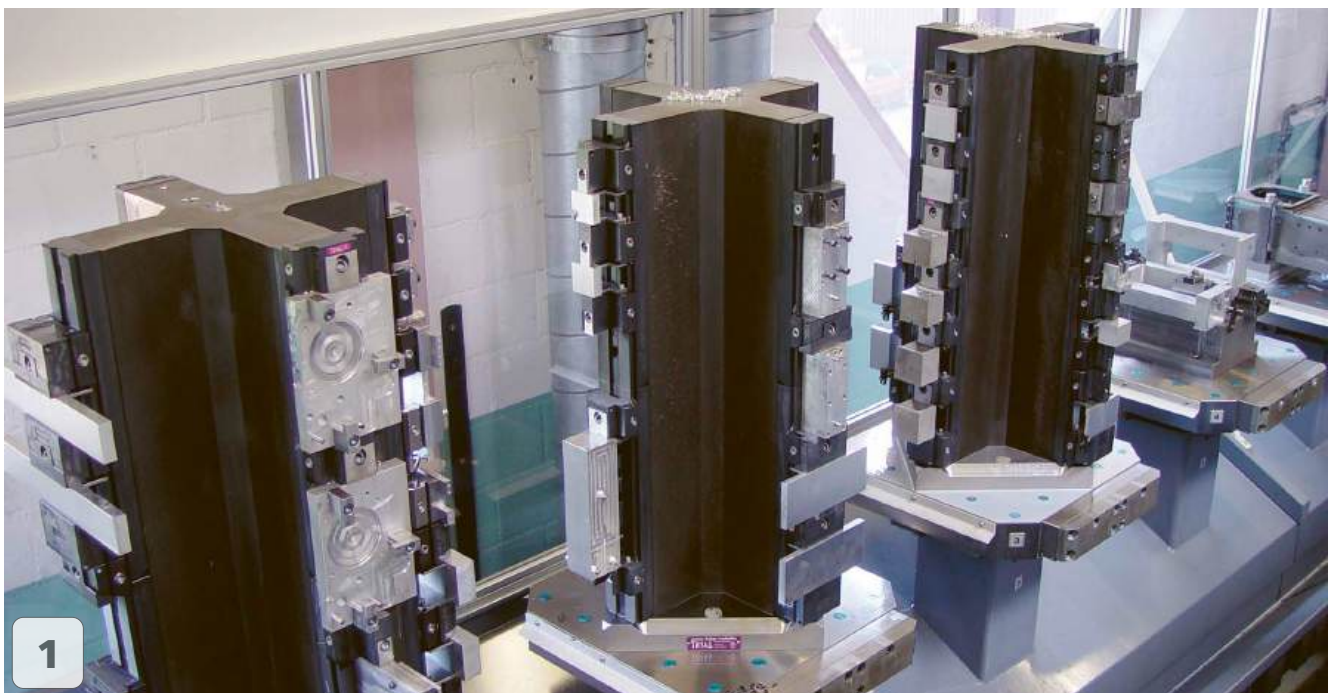
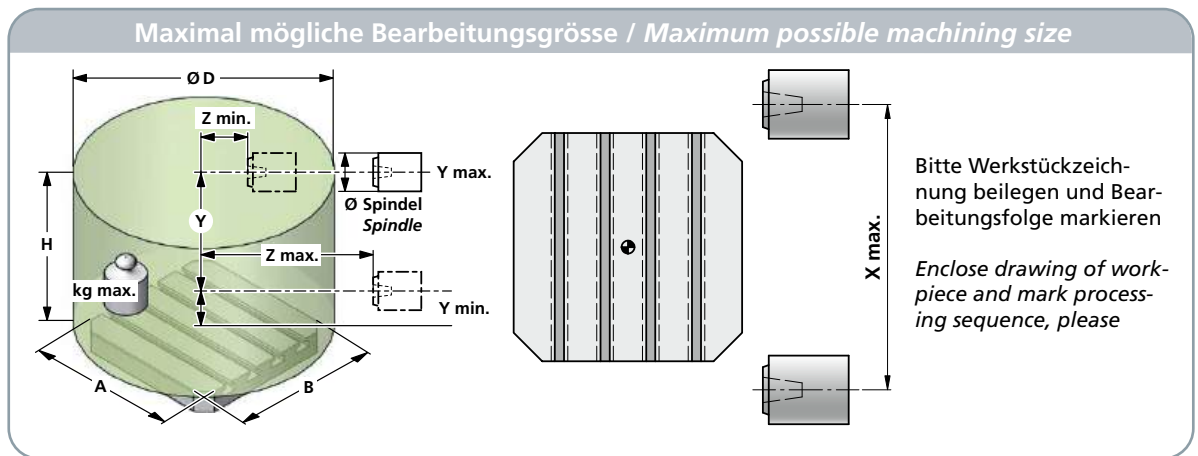

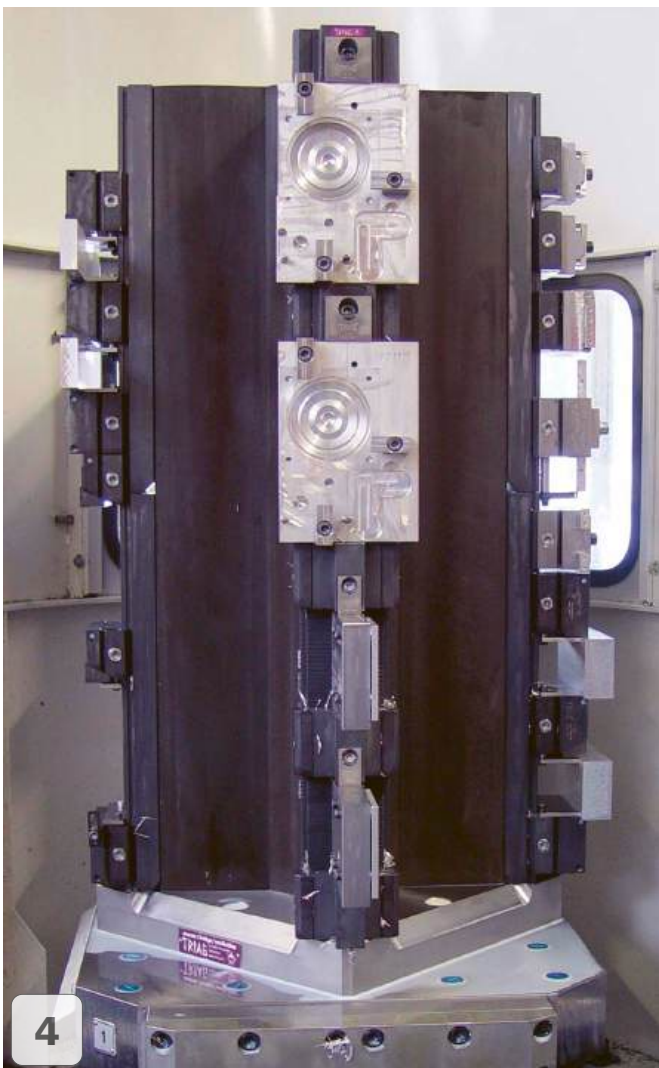
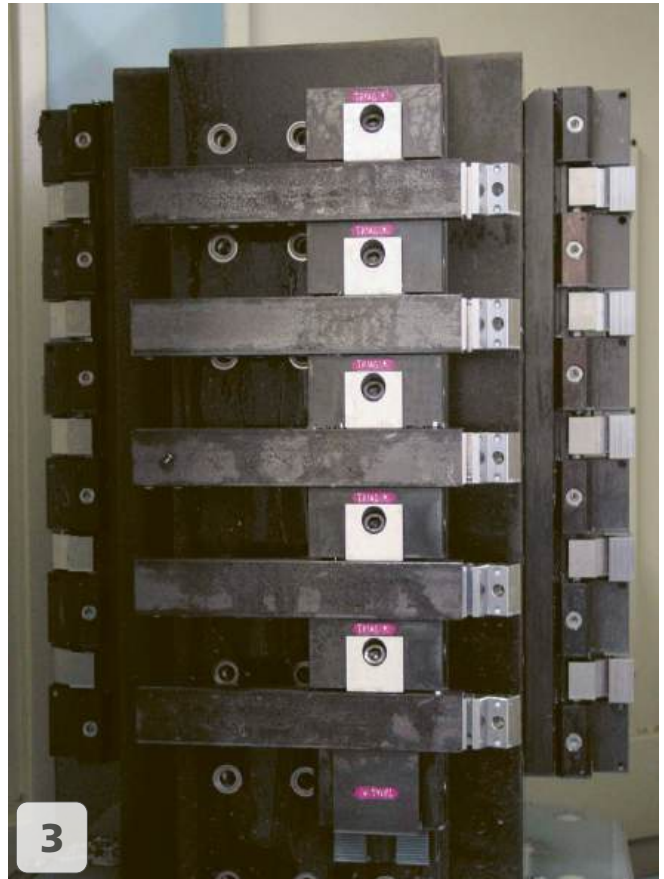
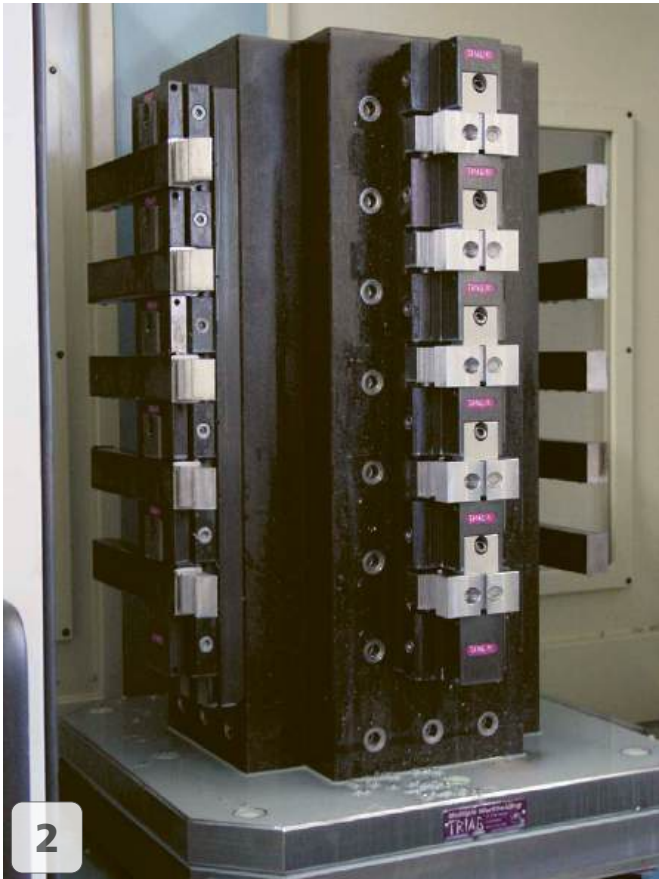

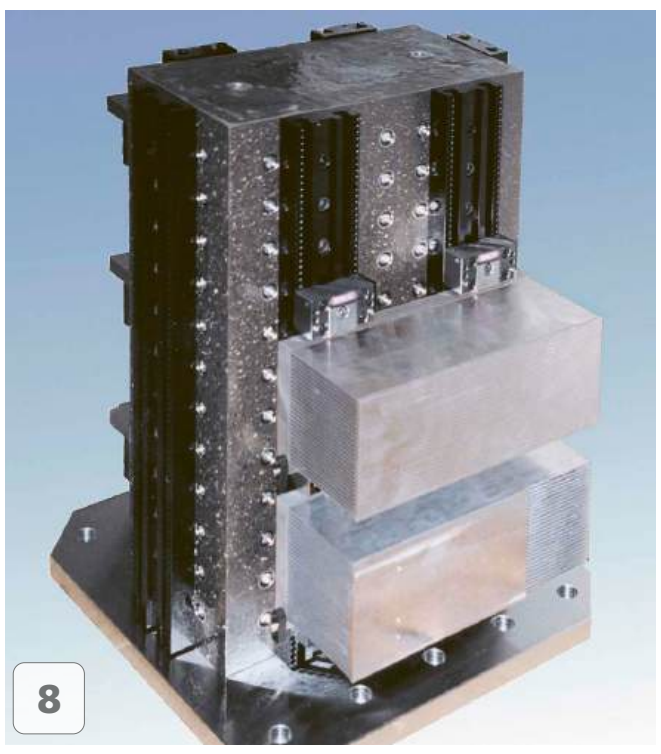
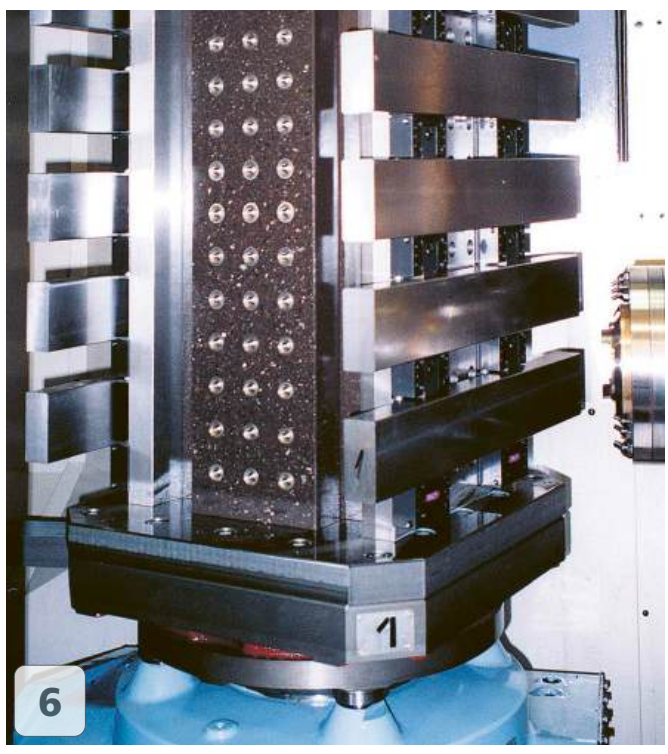

Stahl-Mineralguss Lösungen / Steel epoxy mineral tombstones solutions

SMK24-24-42 OPP200 ~ 120kg



Pyramidenstumpf  
Truncated pyramid ~ 474kg

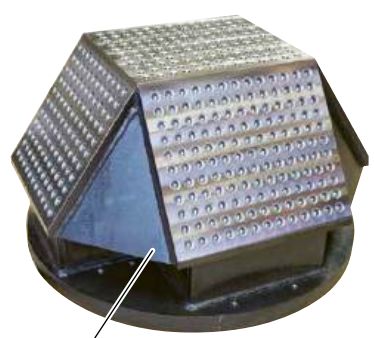

SMK30-17-42 OPP200 ~ 142kg

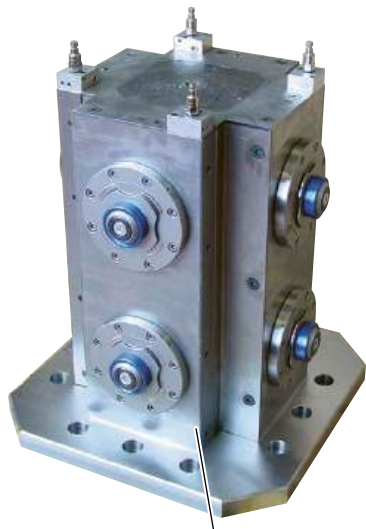

Turm-Material <i>Tombstone material</i>	
M	Mineralguss mit Stahldübel <i>Epoxy mineral with steel anchor</i>
SM	Stahl Mineralguss <i>Steel epoxy mineral tombstones</i>
G	Grauguss <i>Cast iron</i>

Grösste Schlüsselweite <i>Major width</i>	
12	120 mm
20	200 mm
24	240 mm
25	250 mm
30	300 mm
32	320 mm
35	350 mm
40	400 mm
42	420 mm
50	500 mm
60	600 mm
63	630 mm
70	700 mm

Höhe <i>Height</i>	
50	500 mm
55	550 mm
56	567 mm
60	600 mm
62	620 mm
65	650 mm
66	660 mm
70	700 mm
75	750 mm
80	800 mm
85	850 mm
90	900 mm
95	950 mm

**M**

**K**

**35**

**18**

**95**

**R50**

Modultyp <i>Type of module</i>	
K	Kreuz <i>Cross</i>
Q	Quadrat <i>Square</i>
R	Rechteck <i>Rectangular</i>
S	Sechseck <i>Hexagonal</i>
A	Achteck <i>Octagonal</i>
X	Spezialform <i>Special shape</i>

Aufspannbreite <i>Usable width</i>	
08	80 mm
09	90 mm
86	86 mm
10	100 mm
12	120 mm
15	150 mm
16	160 mm
18	180 mm
1808	180 / 80 mm
19	184 mm
20	200 mm
23	231 mm
24	240 mm
25	250 mm
30	300 mm
35	350 mm
40	400 mm
42	420 mm

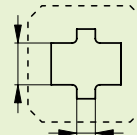

Raster <i>Grid</i>	
R40	40 mm
R50	50 mm
R80	80 mm
R100	100 mm
OPP	200 mm

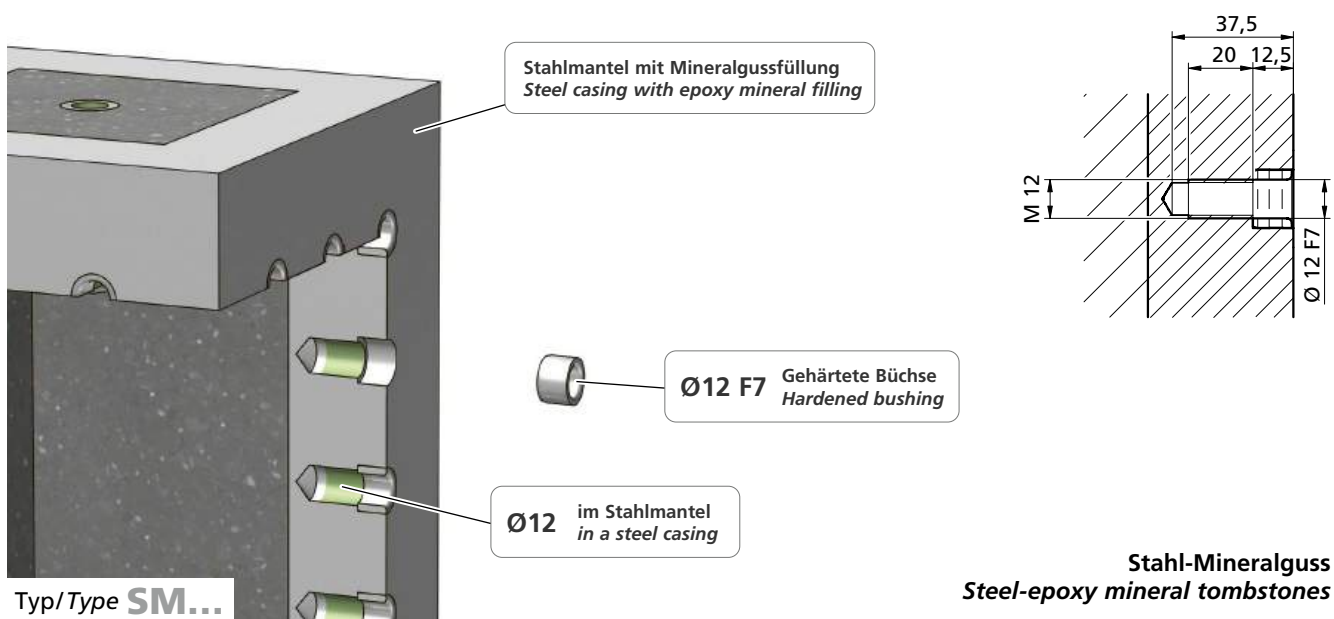
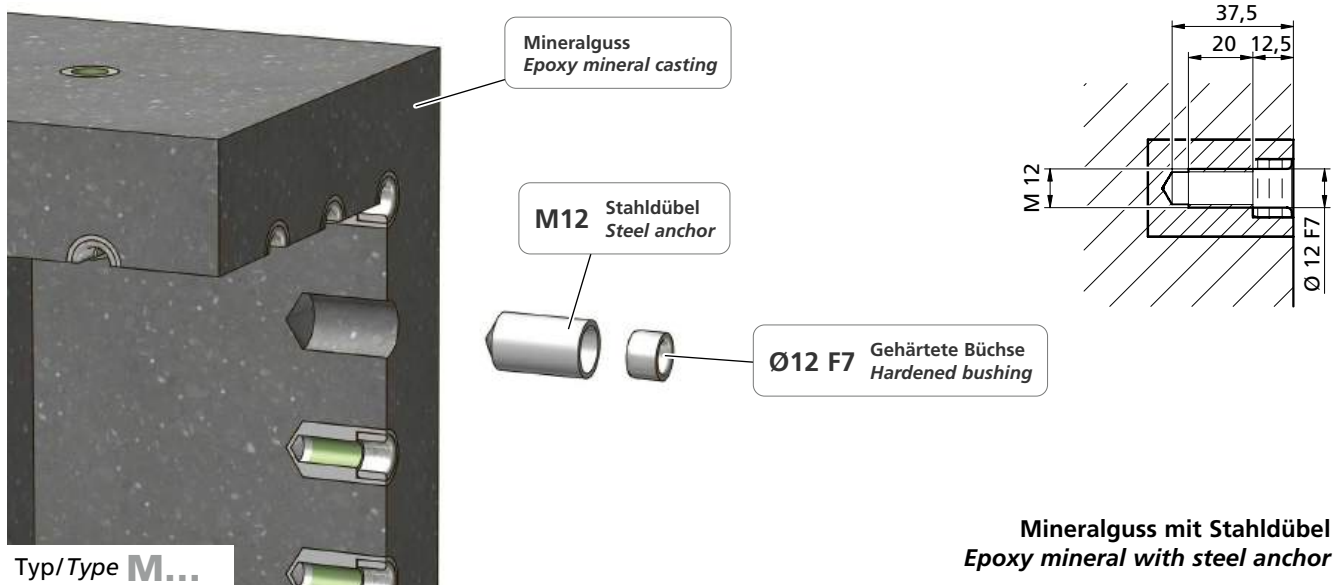

Art. Nr.	kg	Raster / Grid	H
<b>MK200950R50</b>	~73	36 x M12/12F7	500
<b>MK200955R50</b>	~40	40 x M12/12F7	550
<b>MK200960R50</b>	~44	44 x M12/12F7	600
<b>MK200965R50</b>	~47	48 x M12/12F7	650
<b>MK200970R50</b>	~51	52 x M12/12F7	700
<b>MK300950R50</b>	~58	36 x M12/12F7	500
<b>MK300955R50</b>	~64	40 x M12/12F7	550
<b>MK300960R50</b>	~70	44 x M12/12F7	600
<b>MK300965R50</b>	~75	48 x M12/12F7	650
<b>MK300970R50</b>	~81	52 x M12/12F7	700
<b>MK300975R50</b>	~87	56 x M12/12F7	750

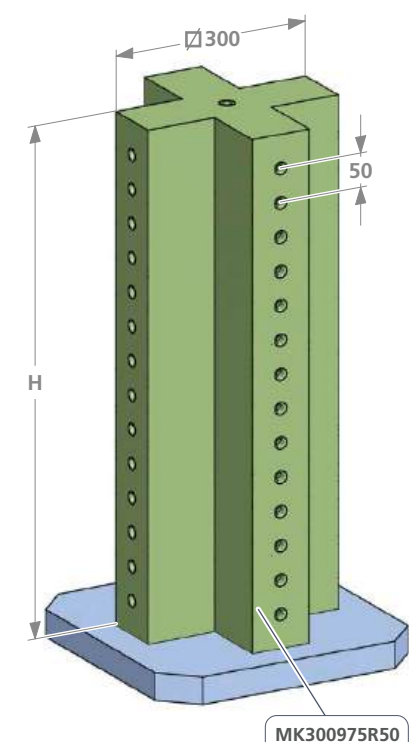
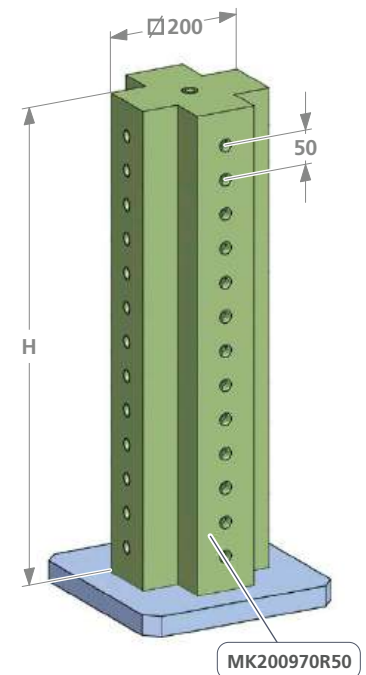

Art. Nr.	kg	Raster / Grid	H
<b>MK350865R50</b>	~83	48 x M12/12F7	650
<b>MK350870R50</b>	~89	52 x M12/12F7	700
<b>MK350875R50</b>	~96	56 x M12/12F7	750
<b>MK350880R50</b>	~102	60 x M12/12F7	800
<b>MK350885R50</b>	~108	64 x M12/12F7	850
<b>MK350890R50</b>	~115	68 x M12/12F7	900
<b>MK350895R50</b>	~121	72 x M12/12F7	950

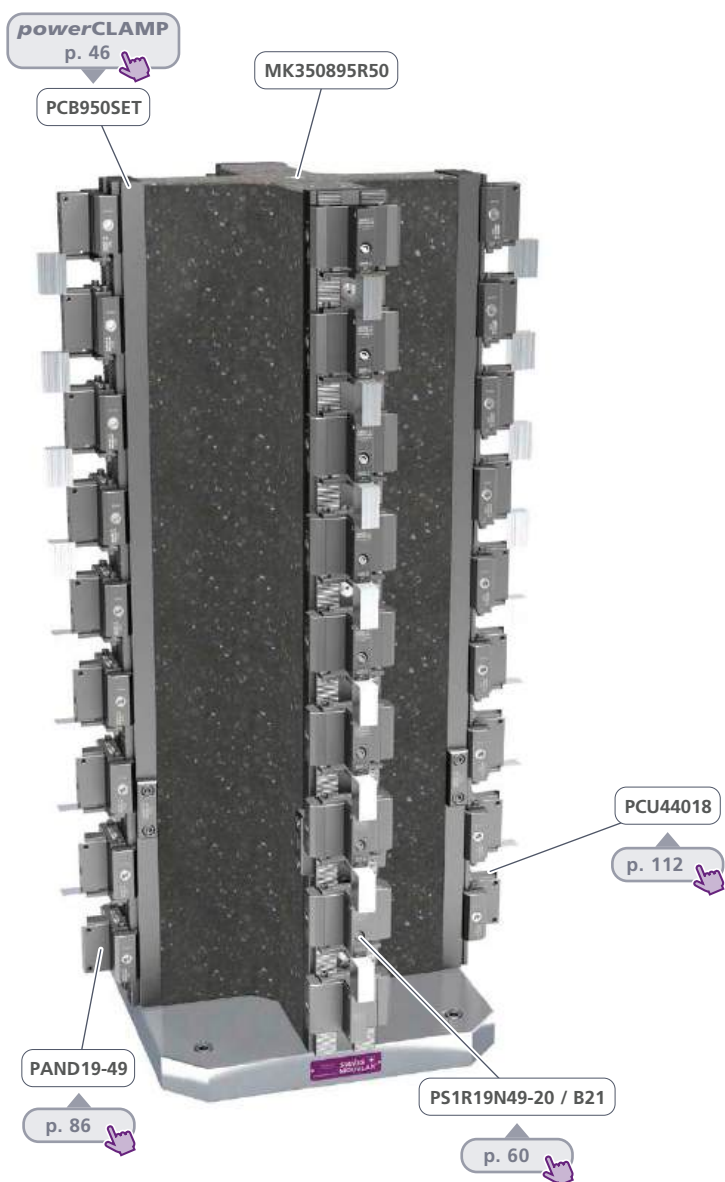
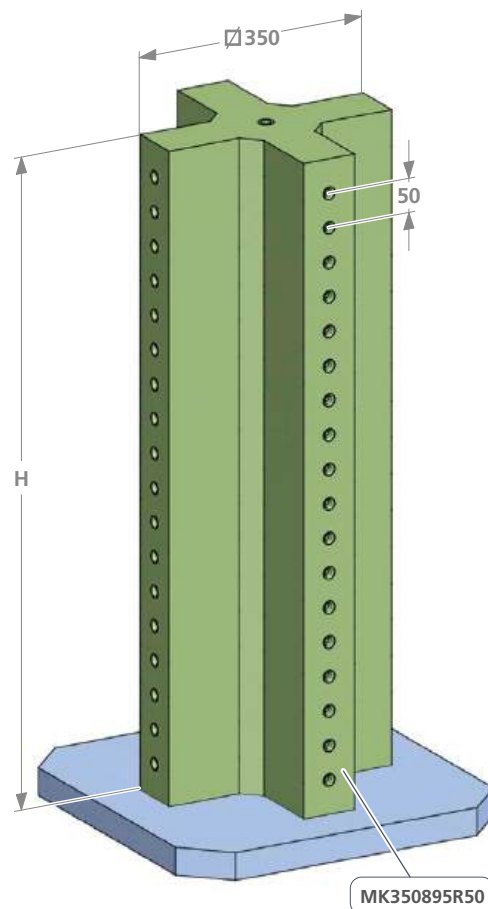

Art. Nr.	kg	Raster / Grid	H
<b>MK301845R50</b>	~73	96 x M12/12F7	450
<b>MK301850R50</b>	~81	108 x M12/12F7	500
<b>MK301855R50</b>	~88	120 x M12/12F7	550
<b>MK301860R50</b>	~95	132 x M12/12F7	600
<b>MK301865R50</b>	~102	144 x M12/12F7	650
<b>MK301870R50</b>	~109	156 x M12/12F7	700
<b>MK301875R50</b>	~116	168 x M12/12F7	750
<b>SMK301845R50</b>	~113	96 x M12/12F7	450
<b>SMK301850R50</b>	~124	108 x M12/12F7	500
<b>SMK301855R50</b>	~135	120 x M12/12F7	550
<b>SMK301860R50</b>	~146	132 x M12/12F7	600
<b>SMK301865R50</b>	~157	144 x M12/12F7	650
<b>SMK301870R50</b>	~168	156 x M12/12F7	700
<b>SMK301875R50</b>	~179	168 x M12/12F7	750

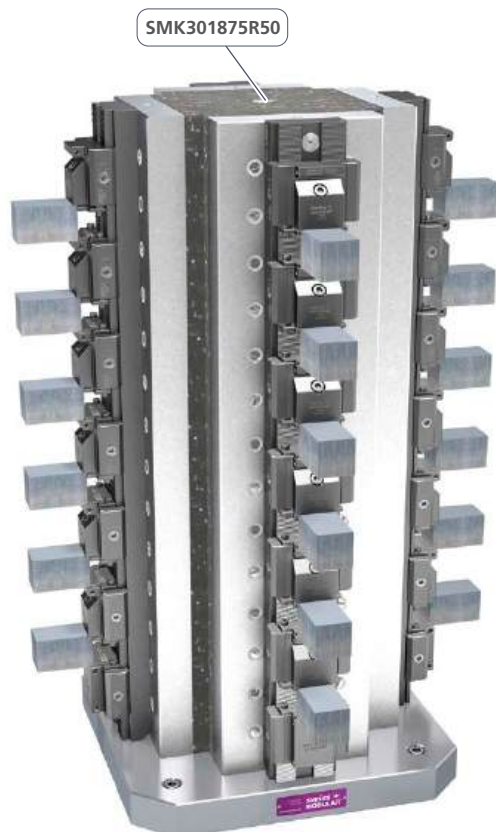
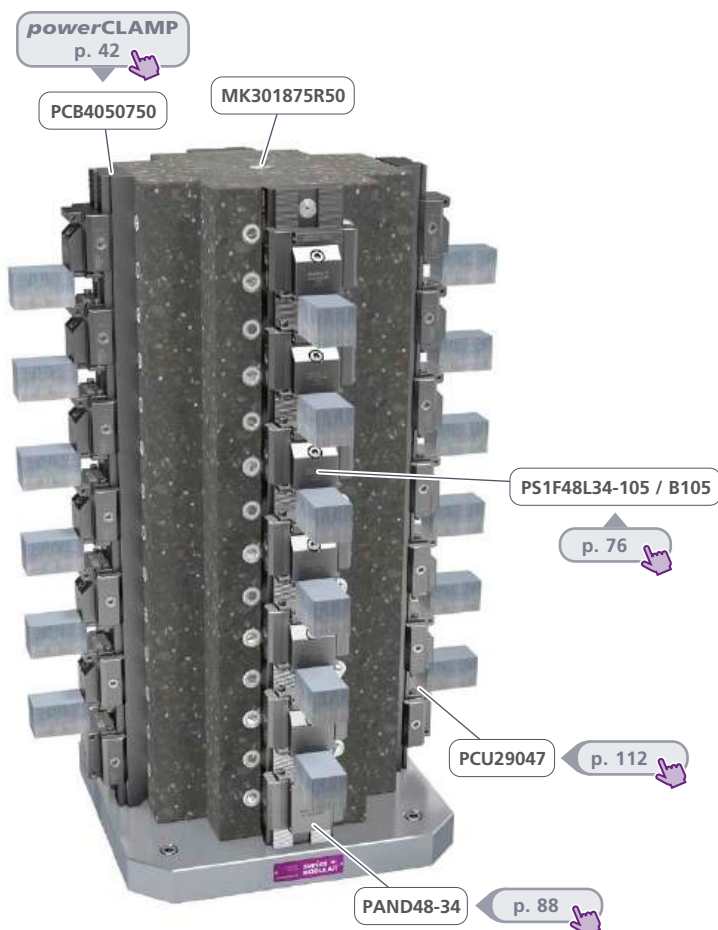
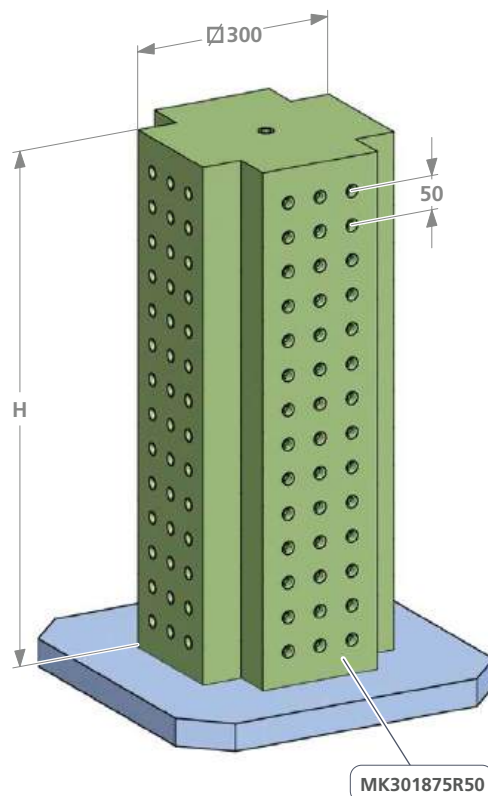

Art. Nr.	kg	Raster / Grid	H
<b>MK321075R100</b>	~97	20 x M12/12F7	750
<b>MK321080R100</b>	~103	24 x M12/12F7	800
<b>MK321085R100</b>	~110	28 x M12/12F7	850
<b>MK321090R100</b>	~116	32 x M12/12F7	900
<b>MK321095R100</b>	~123	36 x M12/12F7	950
<b>MK321875R100</b>	~149	20 x M12/12F7	750
<b>MK321880R100</b>	~159	24 x M12/12F7	800
<b>MK321885R100</b>	~169	28 x M12/12F7	850
<b>MK321890R100</b>	~178	32 x M12/12F7	900
<b>MK321895R100</b>	~188	36 x M12/12F7	950

Auf Anfrage erhältlich  
Available on request

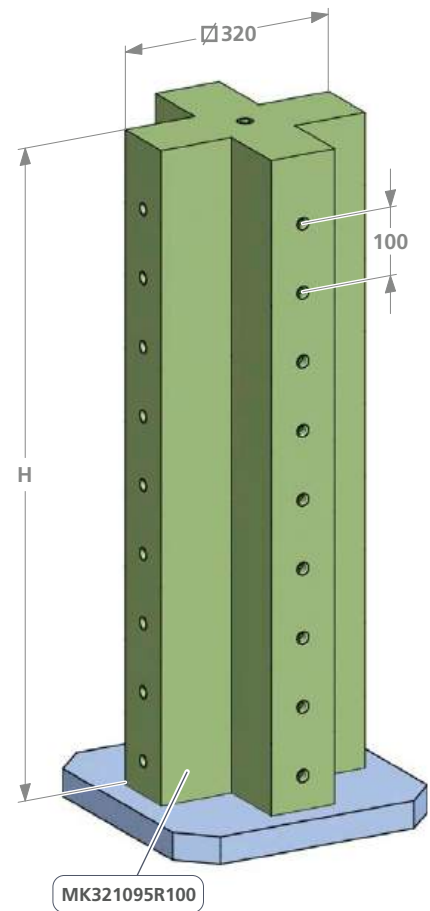

MK321095R100

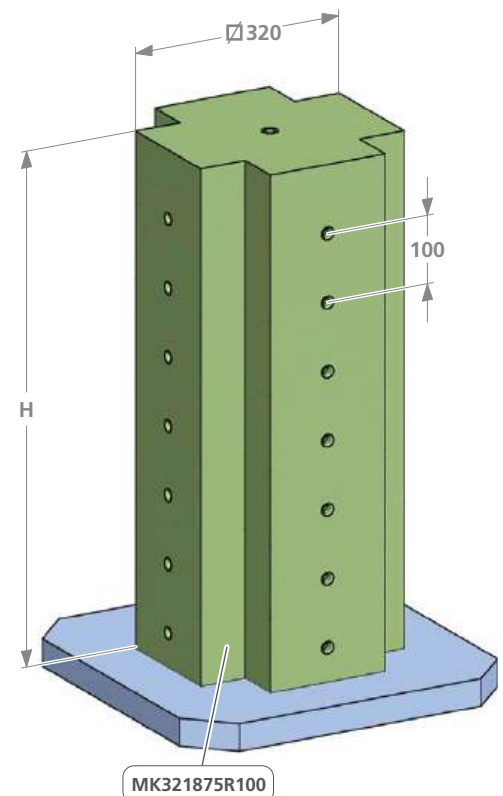
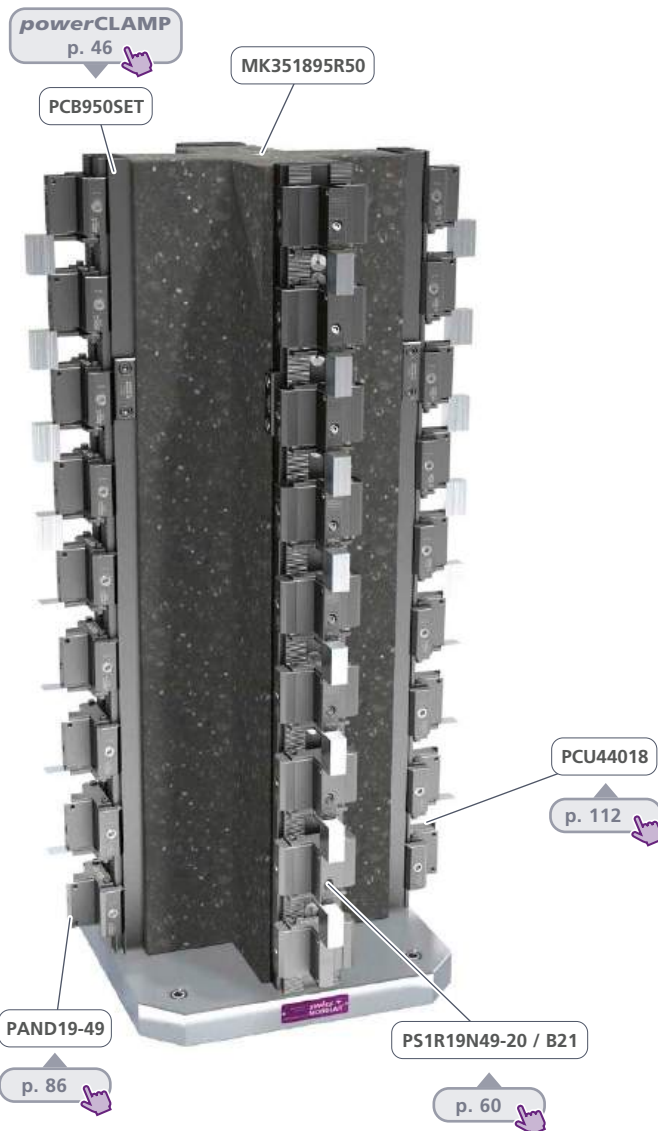

MK321875R100

Art. Nr.	kg	Raster / Grid	H
<b>MK351865R50</b>	~123	144 x M12/12F7	650
<b>MK351870R50</b>	~133	156 x M12/12F7	700
<b>MK351875R50</b>	~142	168 x M12/12F7	750
<b>MK351880R50</b>	~151	180 x M12/12F7	800
<b>MK351885R50</b>	~159	192 x M12/12F7	850
<b>MK351890R50</b>	~168	204 x M12/12F7	900
<b>MK351895R50</b>	~176	216 x M12/12F7	950



<b>SMK351865R50</b>	~180	144 x M12/12F7	650
<b>SMK351870R50</b>	~193	156 x M12/12F7	700
<b>SMK351875R50</b>	~205	168 x M12/12F7	750
<b>SMK351880R50</b>	~218	180 x M12/12F7	800
<b>SMK351885R50</b>	~231	192 x M12/12F7	850
<b>SMK351890R50</b>	~243	204 x M12/12F7	900
<b>SMK351895R50</b>	~256	216 x M12/12F7	950

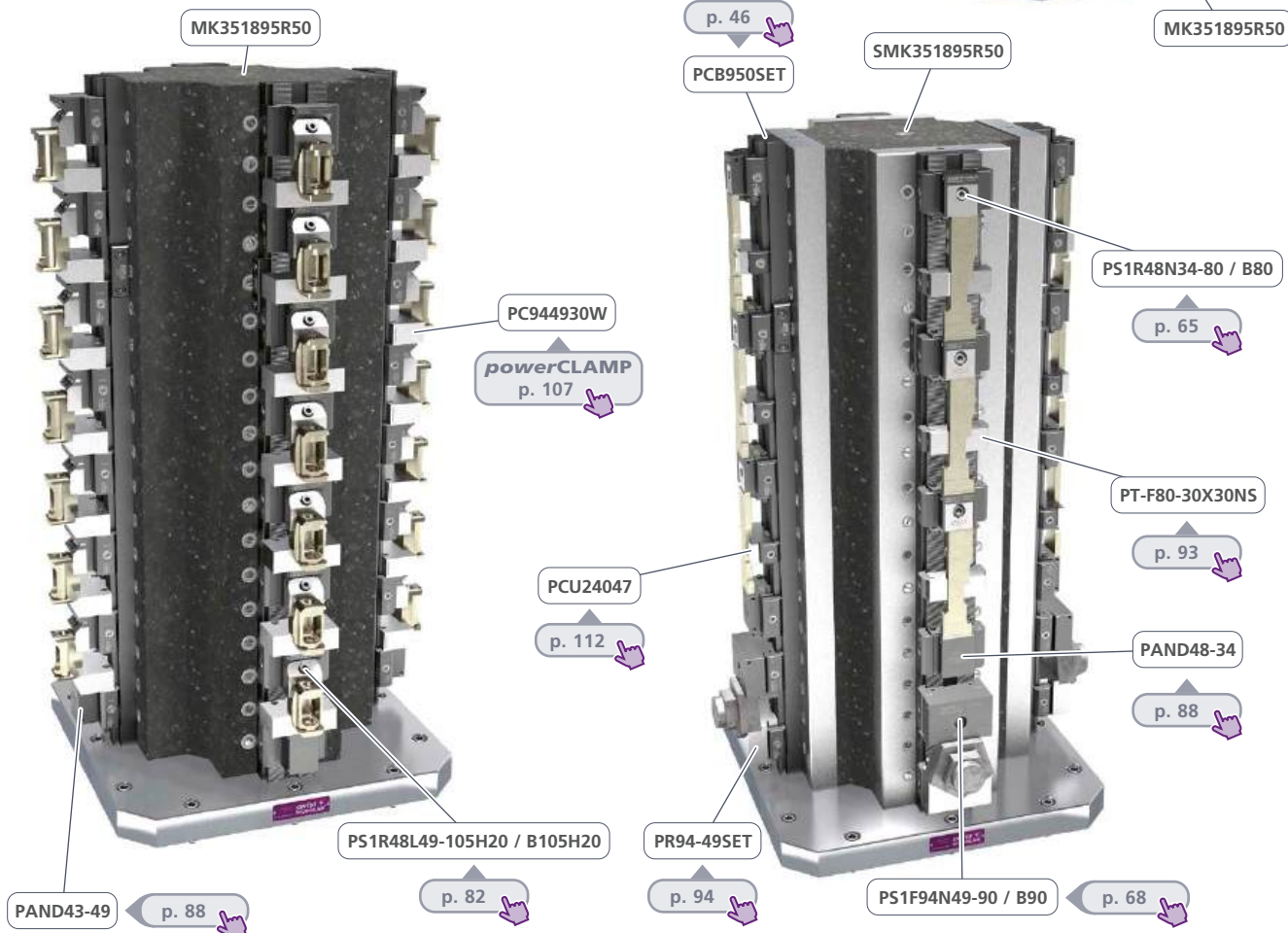
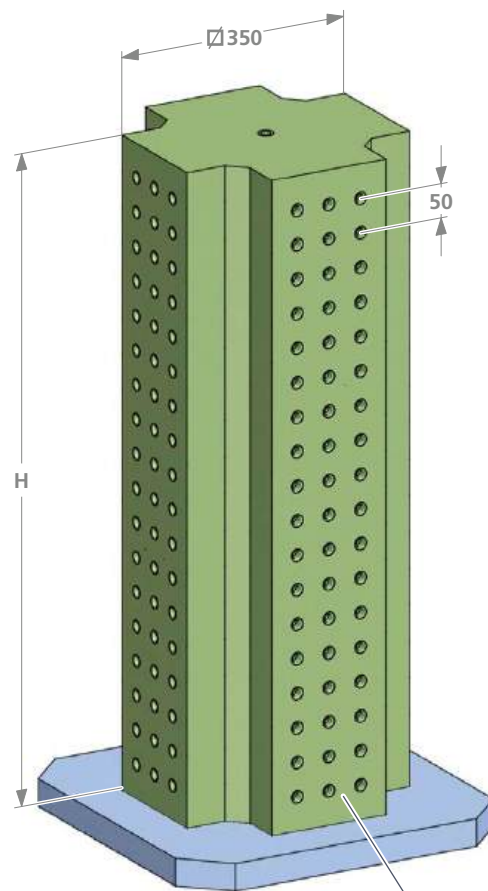

Art. Nr.	kg	Raster / Grid	H
<b>MK401865R50</b>	~151	144 x M12/12F7	650
<b>MK401870R50</b>	~162	156 x M12/12F7	700
<b>MK401875R50</b>	~172	168 x M12/12F7	750
<b>MK401880R50</b>	~183	180 x M12/12F7	800
<b>MK401885R50</b>	~193	192 x M12/12F7	850
<b>MK401890R50</b>	~204	204 x M12/12F7	900
<b>MK401895R50</b>	~214	216 x M12/12F7	950

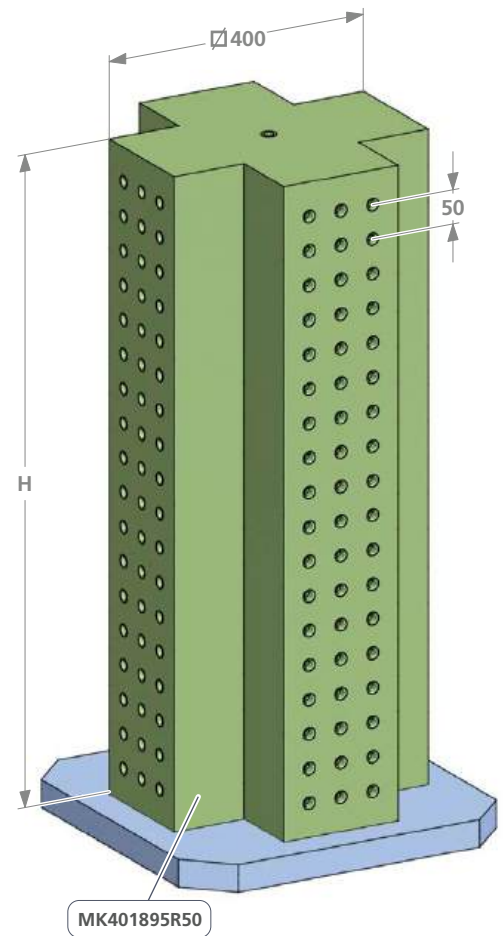

Art. Nr.	kg	Raster / Grid	H
<b>MQ161630R50</b>	~19	20 x M12/12F7	300
<b>MQ161635R50</b>	~22	24 x M12/12F7	350
<b>MQ161640R50</b>	~25	28 x M12/12F7	400
<b>MQ161645R50</b>	~28	32 x M12/12F7	450
<b>MQ161650R50</b>	~31	36 x M12/12F7	500

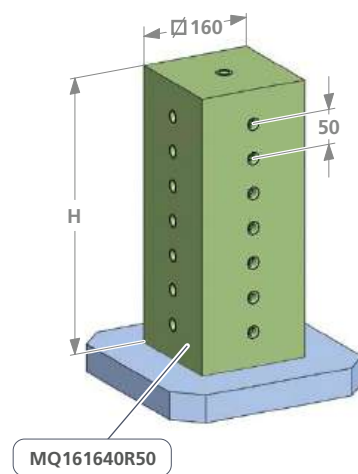

*Maschinenschonend und leicht,  
fast in allen Formen herstellbar.*

*Reduces machine wear due to low  
specific weight - can be produced in  
all sorts of shapes.*

Art. Nr.	kg	Raster / Grid	H
<b>MQ202040R50</b>	~42	84 x M12/12F7	400
<b>MQ202045R50</b>	~53	96 x M12/12F7	450
<b>MQ202050R50</b>	~59	108 x M12/12F7	500
<b>MQ202055R50</b>	~64	120 x M12/12F7	550
<b>MQ202060R50</b>	~70	132 x M12/12F7	600
<b>MQ202065R50</b>	~76	144 x M12/12F7	650
<b>MQ202070R50</b>	~81	156 x M12/12F7	700
<b>MQ242450R50</b>	~81	108 x M12/12F7	500
<b>MQ242455R50</b>	~89	120 x M12/12F7	550
<b>MQ242460R50</b>	~97	132 x M12/12F7	600
<b>MQ242465R50</b>	~103	144 x M12/12F7	650

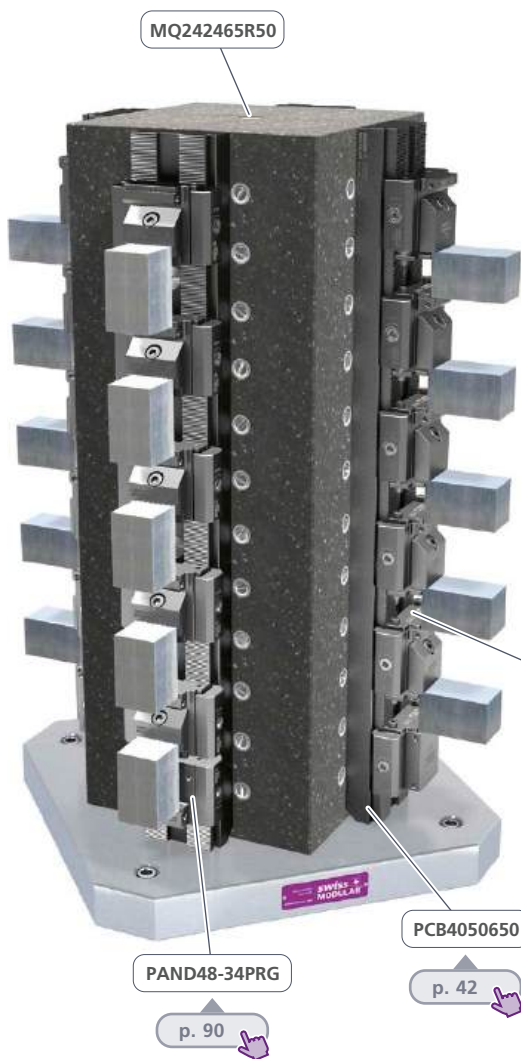
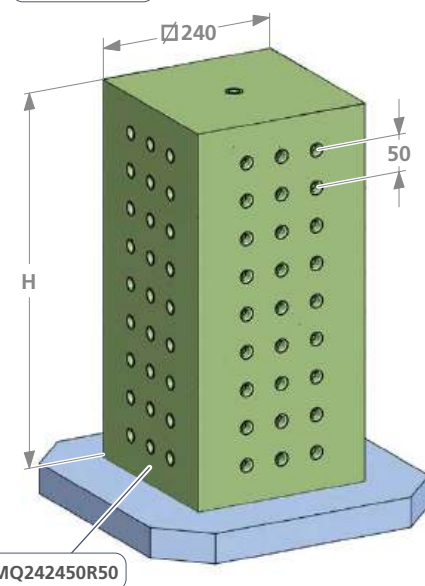
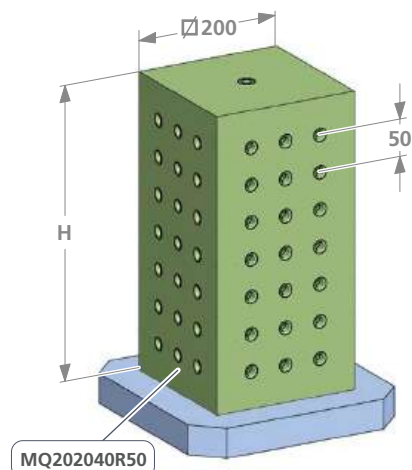

Art. Nr.	kg	Raster / Grid	H
<b>MQ252560R50</b>	~101	176 x M12/12F7	600
<b>MQ252565R50</b>	~109	192 x M12/12F7	650
<b>MQ252570R50</b>	~117	208 x M12/12F7	700
<b>MQ252575R50</b>	~126	224 x M12/12F7	750
<b>MQ252580R50</b>	~134	240 x M12/12F7	800
<b>MQ303050R50</b>	~102	180 x M12/12F7	500
<b>MQ303055R50</b>	~111	200 x M12/12F7	550
<b>MQ303060R50</b>	~120	220 x M12/12F7	600
<b>MQ303065R50</b>	~129	240 x M12/12F7	650
<b>MQ303070R50</b>	~138	260 x M12/12F7	700
<b>MQ303075R50</b>	~148	280 x M12/12F7	750

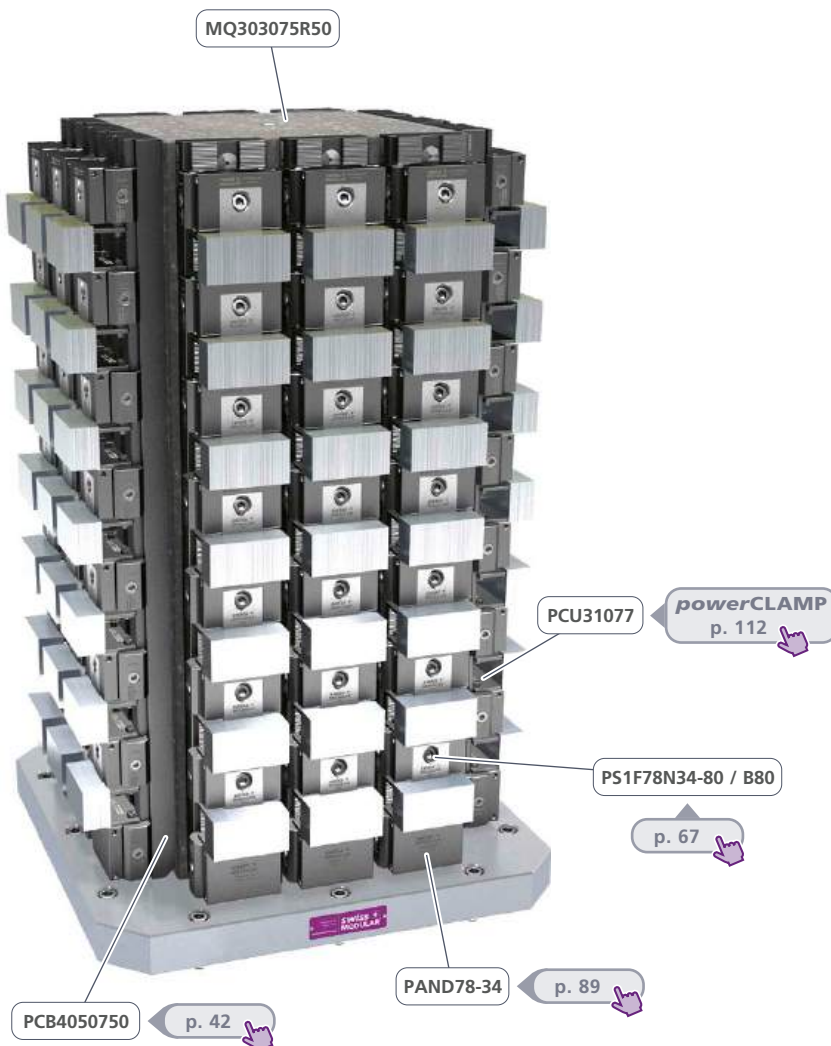
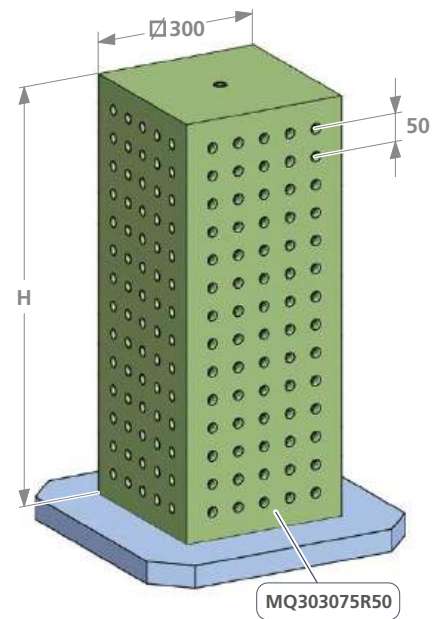
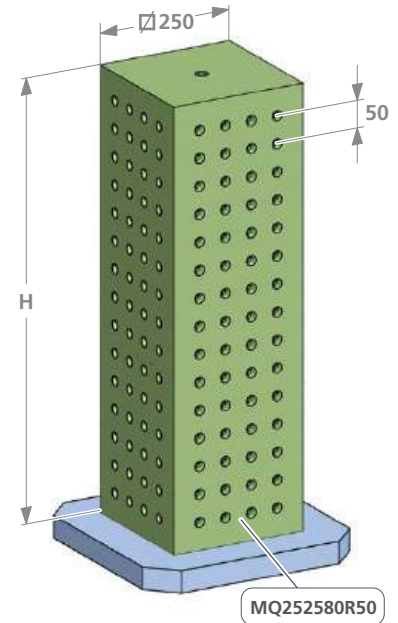

Separat bestellen / Order separately

Art. Nr.	kg	Raster / Grid	H
<b>MQ353565R50</b>	~161	240 x M12/12F7	650
<b>MQ353570R50</b>	~172	260 x M12/12F7	700
<b>MQ353575R50</b>	~183	280 x M12/12F7	750
<b>MQ353580R50</b>	~194	300 x M12/12F7	800
<b>MQ353585R50</b>	~205	320 x M12/12F7	850
<b>MQ353590R50</b>	~216	340 x M12/12F7	900
<b>MQ353595R50</b>	~227	360 x M12/12F7	950
<b>MQ404065R50</b>	~199	336 x M12/12F7	650
<b>MQ404070R50</b>	~212	364 x M12/12F7	700
<b>MQ404075R50</b>	~226	392 x M12/12F7	750
<b>MQ404080R50</b>	~239	420 x M12/12F7	800
<b>MQ404085R50</b>	~252	448 x M12/12F7	850
<b>MQ404090R50</b>	~265	476 x M12/12F7	900
<b>MQ404095R50</b>	~279	504 x M12/12F7	950

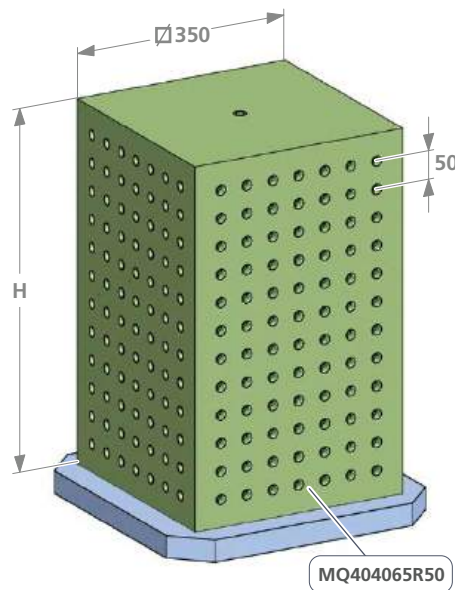
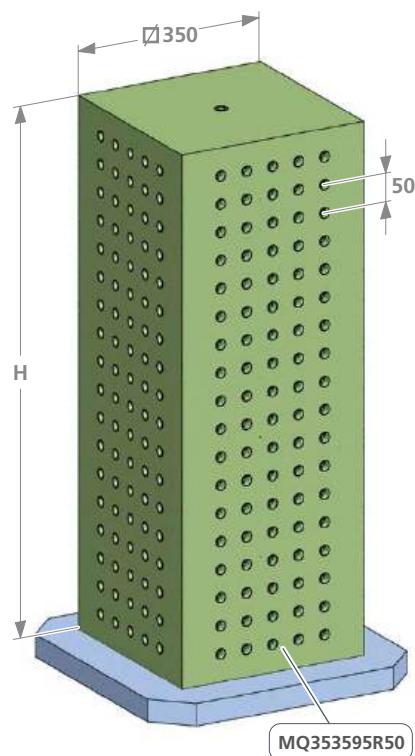

# Mineralgussturm Mineral tombstone

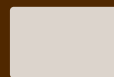

Rechteck  
Rectangle

**tripoxyMINERAL**

Art. Nr.	kg	Raster / Grid	H
<b>MR301550R50-4</b>	~61	63 x M12/12F7	500
<b>MR301555R50-4</b>	~67	70 x M12/12F7	550
<b>MR301560R50-4</b>	~73	77 x M12/12F7	600
<b>MR301565R50-4</b>	~79	84 x M12/12F7	650
<b>MR401245R50</b>	~61	140 x M12/12F7	450
<b>MR401250R50</b>	~68	158 x M12/12F7	500
<b>MR401255R50</b>	~74	176 x M12/12F7	550
<b>MR401260R50</b>	~81	194 x M12/12F7	600

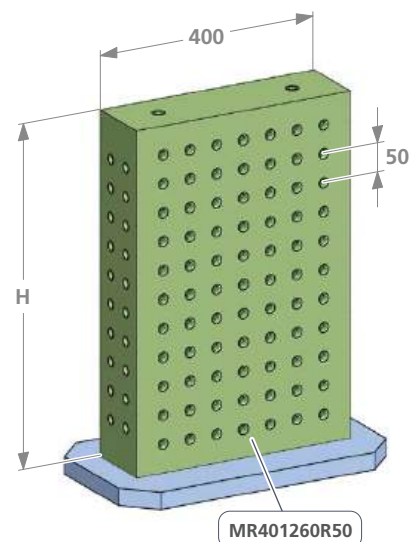
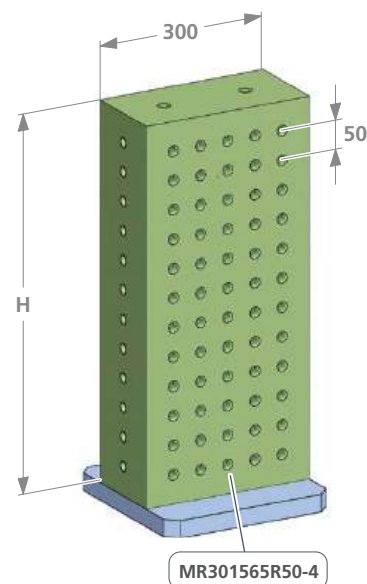

SCAN OR  
CLICK

PDF

STEP

SEPARAT BESTELLEN  
ORDER SEPARATELY

Grundplatte p. 273  
Base platte

# Mineralgussturm Mineral tombstone



Rechteck  
Rectangle

**tripoxyMINERAL**

Art. Nr.	kg	Raster / Grid	H
<b>MR402050R50</b>	~107	180 x M12/12F7	500
<b>MR402055R50</b>	~118	200 x M12/12F7	550
<b>MR402060R50</b>	~129	220 x M12/12F7	600
<b>MR402065R50</b>	~139	240 x M12/12F7	650
<b>MR402070R50</b>	~150	260 x M12/12F7	700
<b>MR402075R50</b>	~161	280 x M12/12F7	750

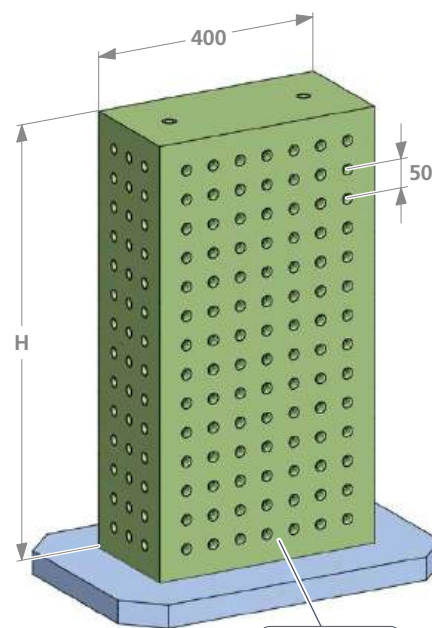

MR402075R50

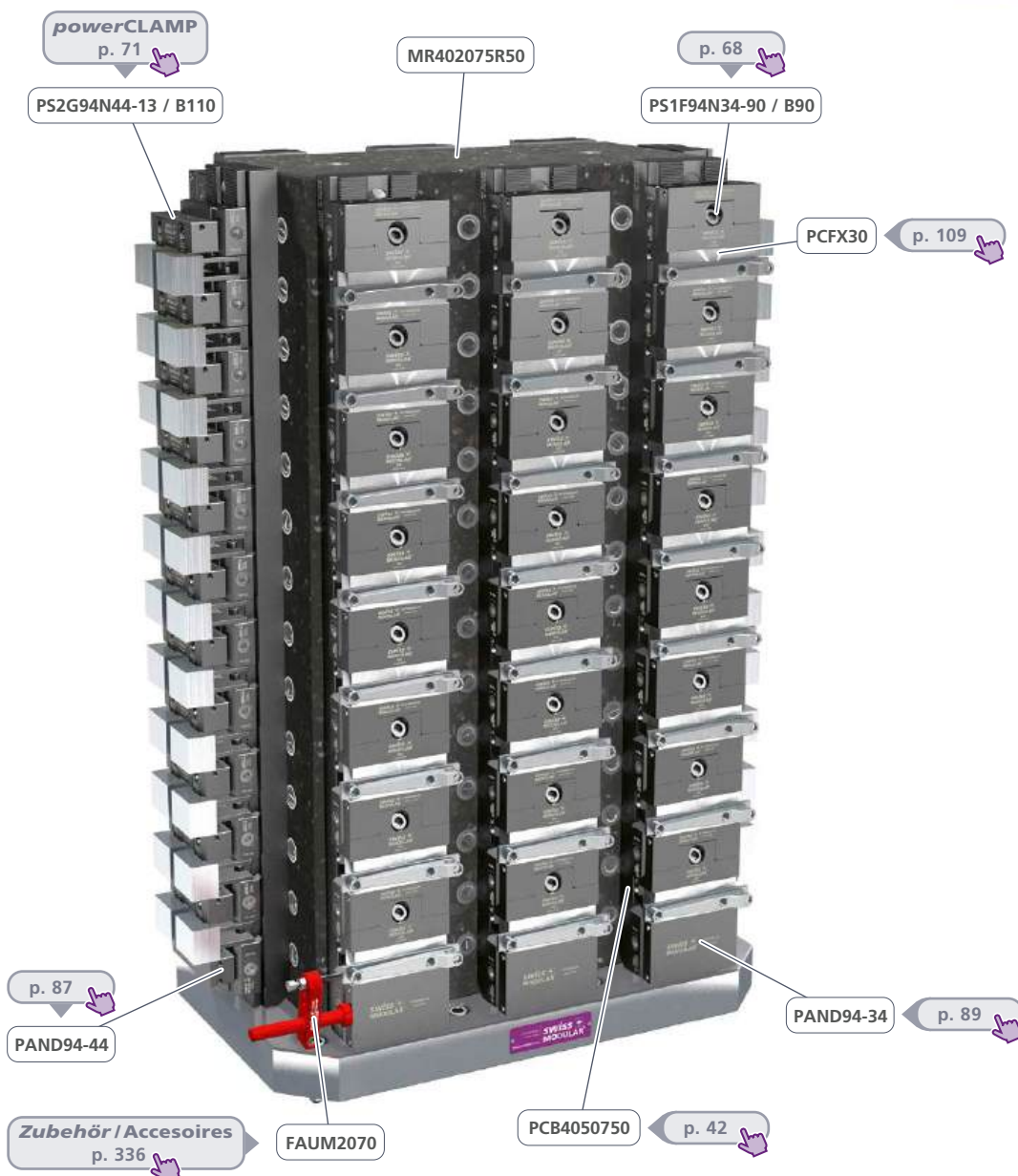

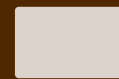

Art. Nr.	kg	Raster / Grid	H
<b>MR502060R50-2</b>	~156	198 x M12/12F7	600
<b>MR502065R50-2</b>	~169	216 x M12/12F7	650
<b>MR502070R50-2</b>	~182	234 x M12/12F7	700
<b>MR502075R50-2</b>	~195	252 x M12/12F7	750
<b>MR502080R50-2</b>	~208	270 x M12/12F7	800
<b>MR502085R50-2</b>	~221	288 x M12/12F7	850
<b>MR502090R50-2</b>	~234	306 x M12/12F7	900
<b>MR502095R50-2</b>	~247	324 x M12/12F7	950
<b>MR502060R50-4</b>	~160	264 x M12/12F7	600
<b>MR502065R50-4</b>	~173	288 x M12/12F7	650
<b>MR502070R50-4</b>	~186	312 x M12/12F7	700
<b>MR502075R50-4</b>	~200	336 x M12/12F7	750
<b>MR502080R50-4</b>	~213	360 x M12/12F7	800
<b>MR502085R50-4</b>	~226	384 x M12/12F7	850
<b>MR502090R50-4</b>	~240	408 x M12/12F7	900
<b>MR502095R50-4</b>	~253	432 x M12/12F7	950

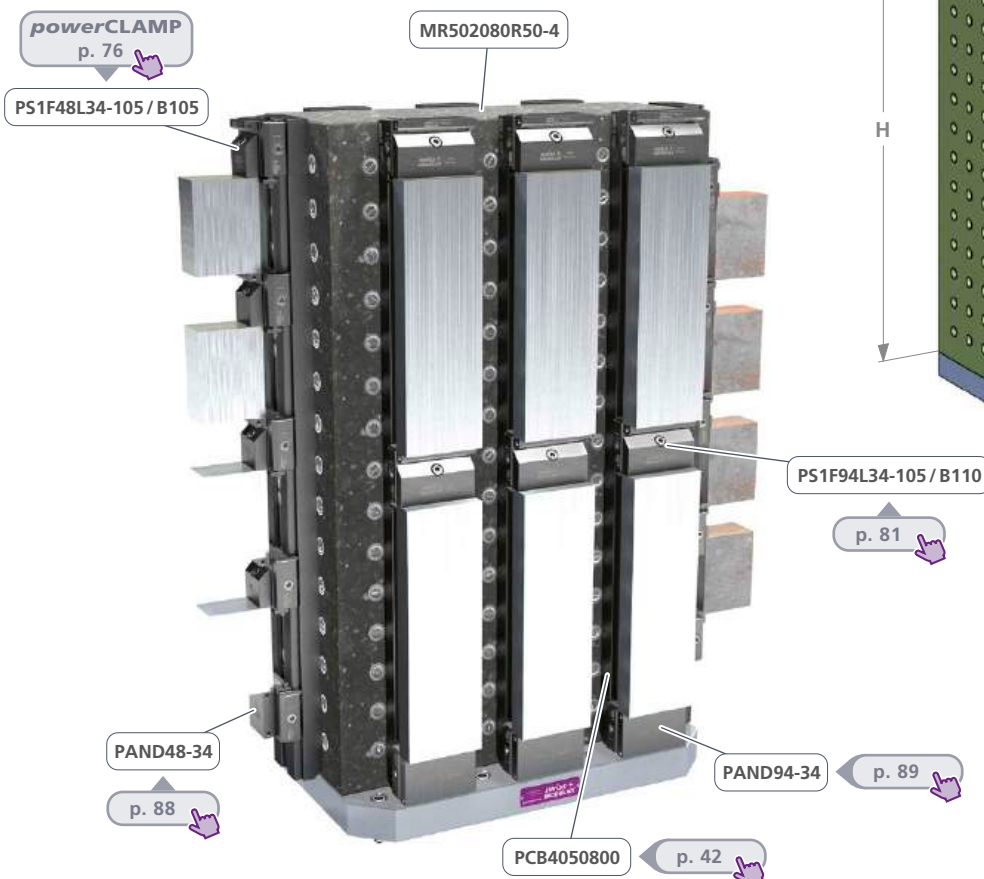
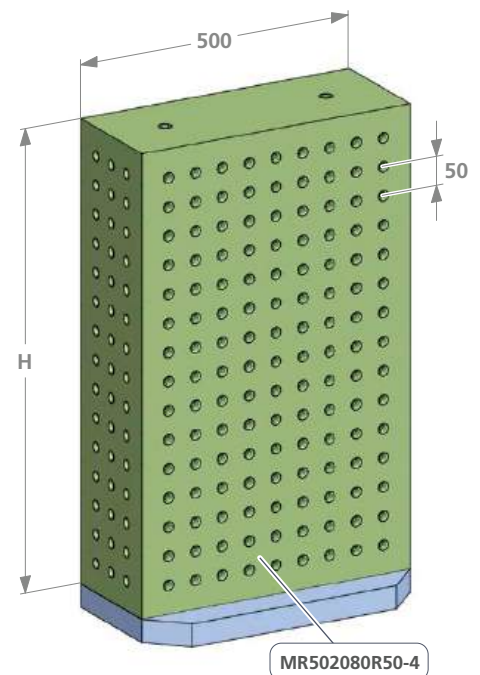
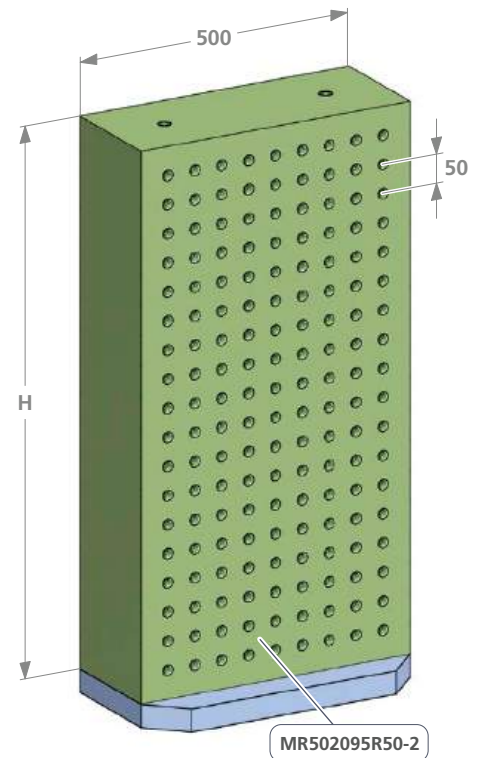

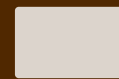

Art. Nr.	kg	Raster / Grid	H
<b>MR602060R50-2</b>	~188	242 x M12/12F7	600
<b>MR602065R50-2</b>	~203	264 x M12/12F7	650
<b>MR602070R50-2</b>	~219	286 x M12/12F7	700
<b>MR602075R50-2</b>	~234	308 x M12/12F7	750
<b>MR602080R50-2</b>	~250	330 x M12/12F7	800
<b>MR602085R50-2</b>	~265	652 x M12/12F7	850
<b>MR602090R50-2</b>	~281	374 x M12/12F7	900
<b>MR602095R50-2</b>	~279	396 x M12/12F7	950
<b>MR602060R50-4</b>	~192	308 x M12/12F7	600
<b>MR602065R50-4</b>	~207	336 x M12/12F7	650
<b>MR602070R50-4</b>	~223	364 x M12/12F7	700
<b>MR602075R50-4</b>	~239	392 x M12/12F7	750
<b>MR602080R50-4</b>	~255	420 x M12/12F7	800
<b>MR602085R50-4</b>	~271	448 x M12/12F7	850
<b>MR602090R50-4</b>	~286	476 x M12/12F7	900
<b>MR602095R50-4</b>	~302	504 x M12/12F7	950

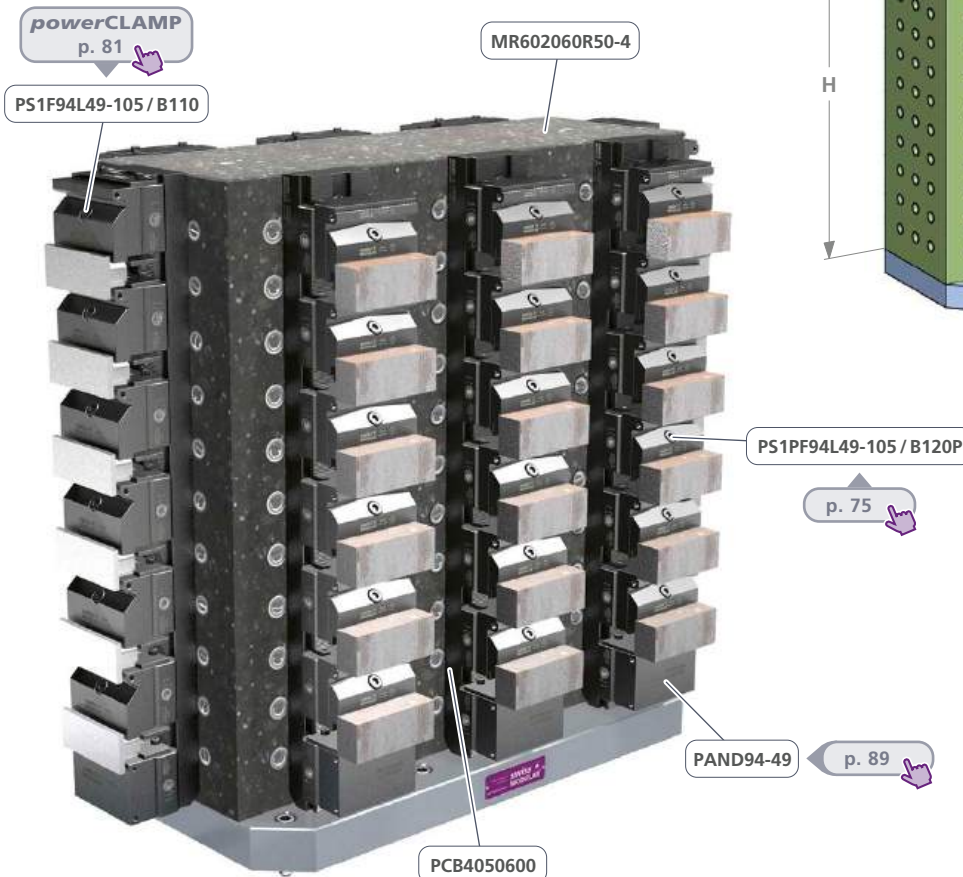
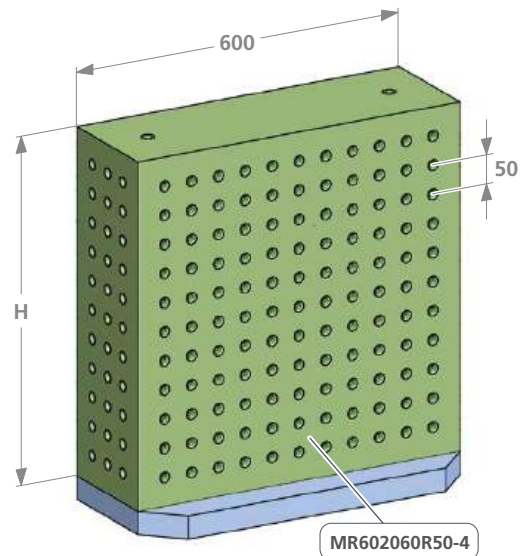
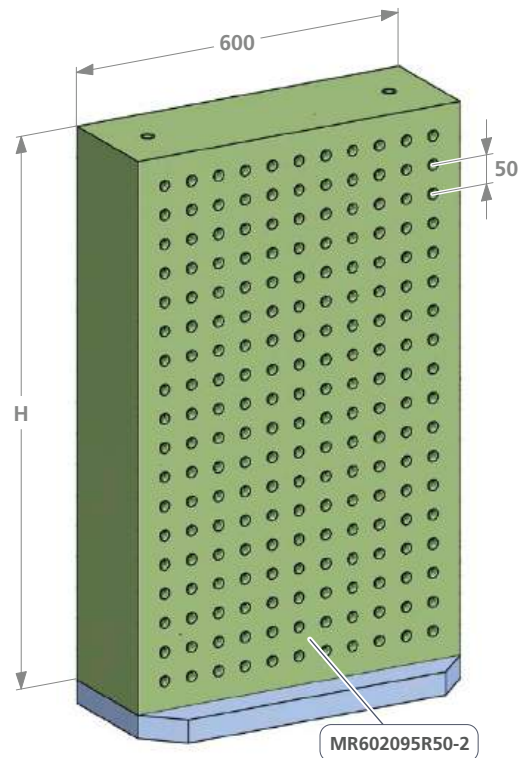

# Mineralgussturm Mineral tombstone

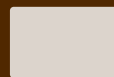

Rechteck  
Rectangle

**tripoxyMINERAL**

Art. Nr.	kg	Raster / Grid	H
<b>MR701550R50</b>	~140	234 x M12/12F7	500
<b>MR701555R50</b>	~154	260 x M12/12F7	550
<b>MR701560R50</b>	~168	286 x M12/12F7	600
<b>MR701560R50</b>	~182	312 x M12/12F7	650
<b>MR701570R50</b>	~196	338 x M12/12F7	700
<b>MR701575R50</b>	~210	750	

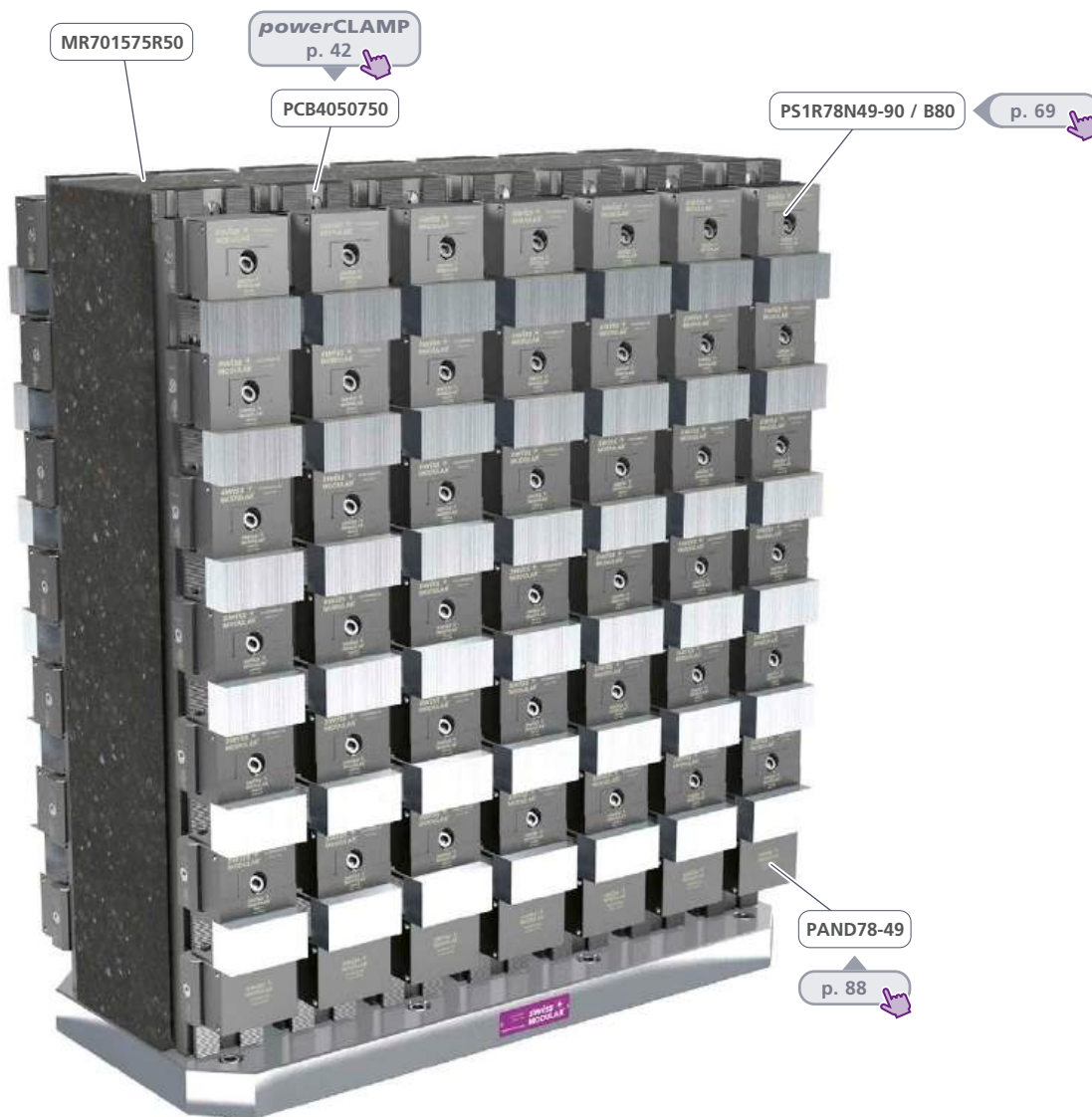
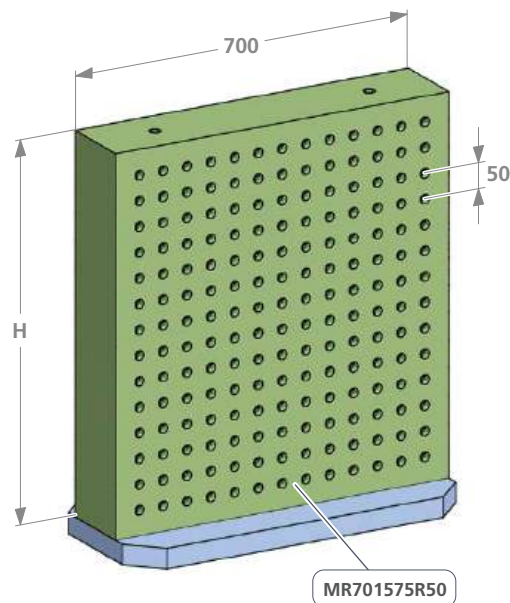

Art. Nr.	kg	Raster / Grid	H
<b>MS321960R50</b>	~111	198 x M12/12F7	600
<b>MS321965R50</b>	~119	216 x M12/12F7	650
<b>MS321970R50</b>	~127	234 x M12/12F7	700
<b>MS321975R50</b>	~135	252 x M12/12F7	750
<b>MS321980R50</b>	~144	270 x M12/12F7	800
<b>MS402366R40</b>	~163	270 x M12/12F7	660
<b>MS402395R40</b>	~223	396 x M12/12F7	950
<b>MS402366R50</b>	~171	216 x M12/12F7	660
<b>MS402395R50</b>	~236	324 x M12/12F7	950



Auf Anfrage erhältlich  
Available on request

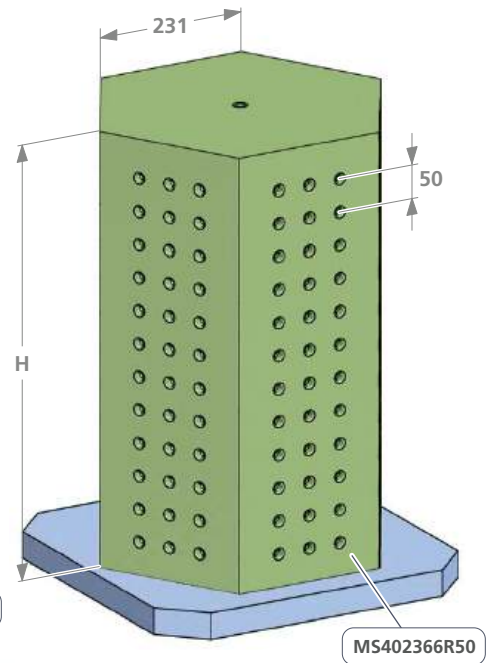
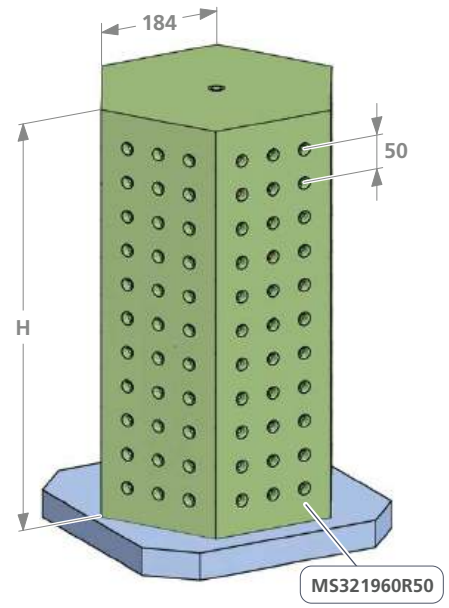

ZSQP160L50UPRG

triCENTRO  
p. 148

powerCLAMP  
p. 42

PCB4050650

MS402366R50

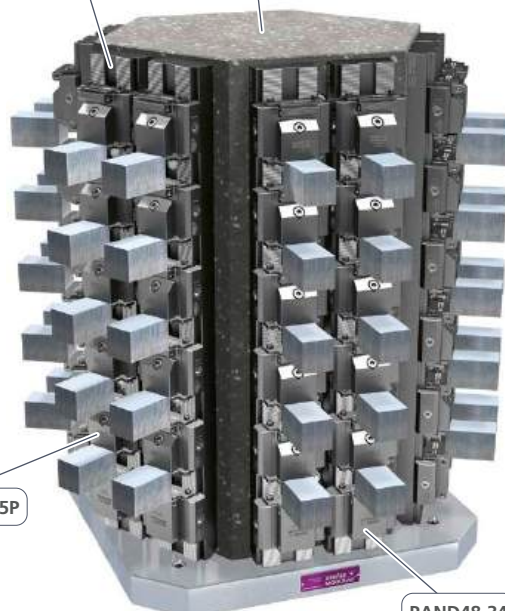

p. 76

PS1F48L34-105 / B105P

PAND48-34

p. 88

Art. Nr.	kg	Raster / Grid	H
<b>MA241050R50-4</b>	~60	36 x M12/12F7	500
<b>MA241055R50-4</b>	~66	40 x M12/12F7	550
<b>MA241060R50-4</b>	~72	44 x M12/12F7	600
<b>MA241065R50-4</b>	~78	48 x M12/12F7	650
<b>MA241050R50-8</b>	~62	72 x M12/12F7	500
<b>MA241055R50-8</b>	~69	80 x M12/12F7	550
<b>MA241060R50-8</b>	~75	88 x M12/12F7	600
<b>MA241065R50-8</b>	~81	96 x M12/12F7	650

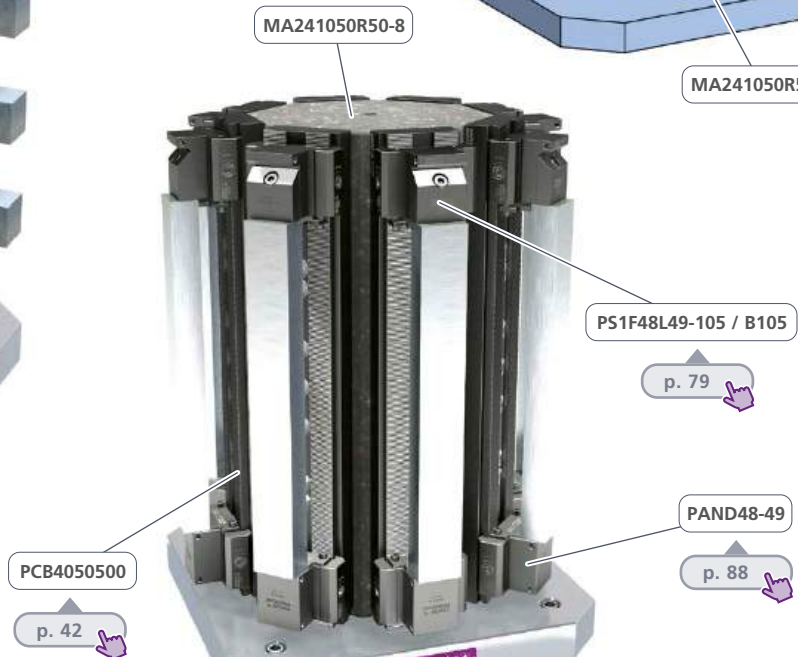
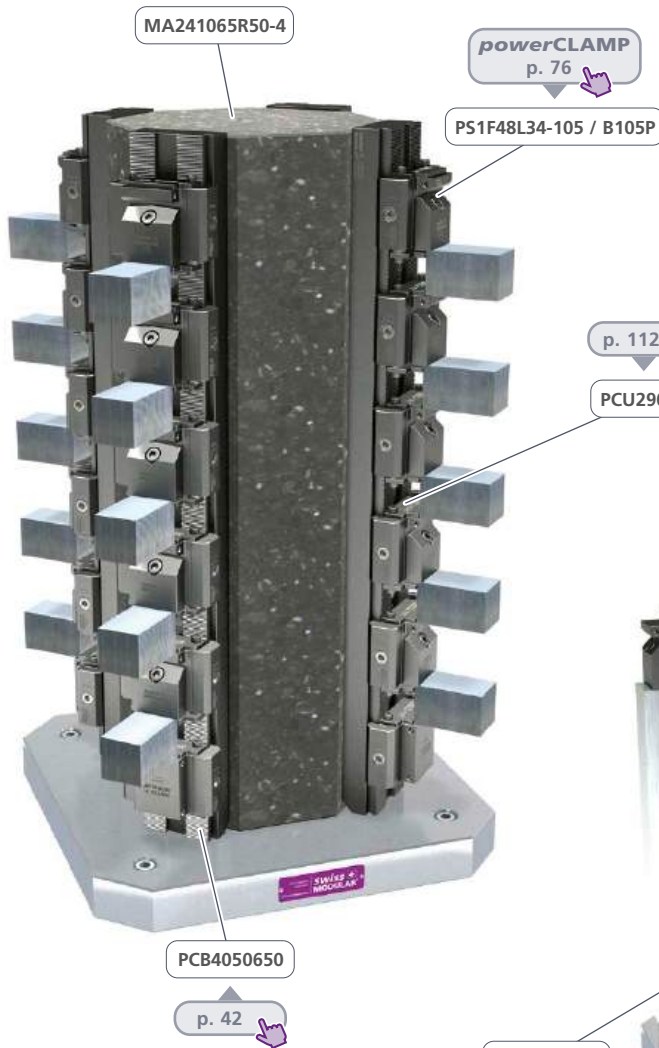
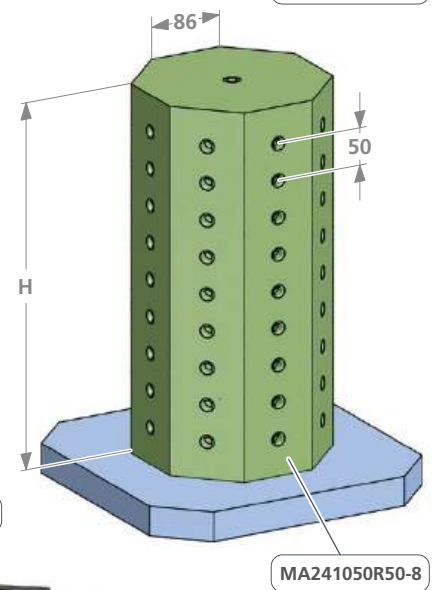
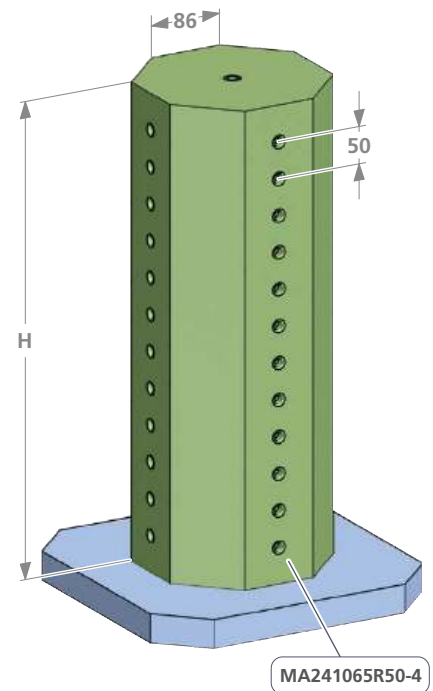

Art. Nr.	kg	Raster / Grid	H
<b>MA301265R50-8-2</b>	~103	192 x M12/12F7	650
<b>MA301270R50-8-2</b>	~111	208 x M12/12F7	700
<b>MA301275R50-8-2</b>	~117	224 x M12/12F7	750

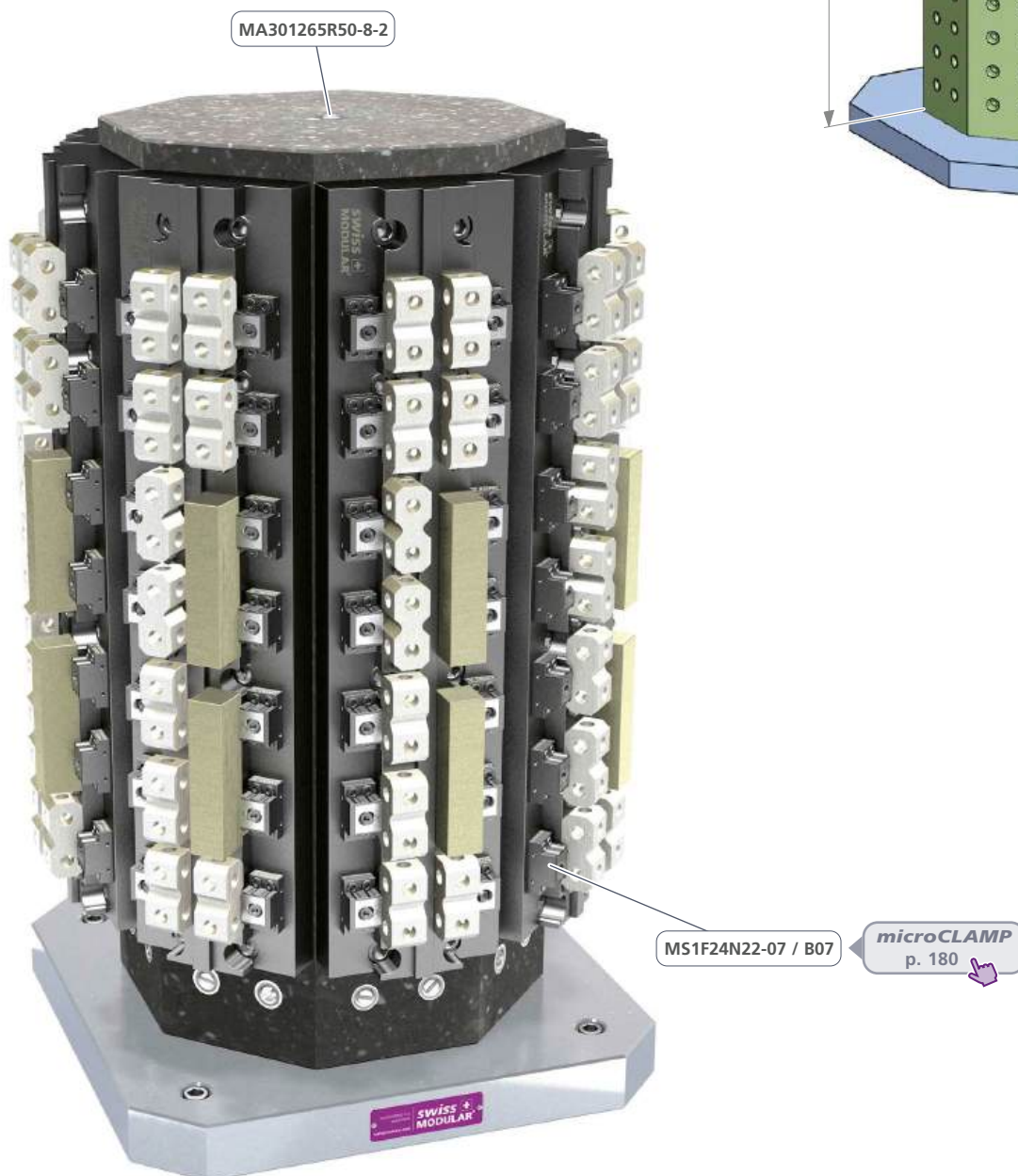
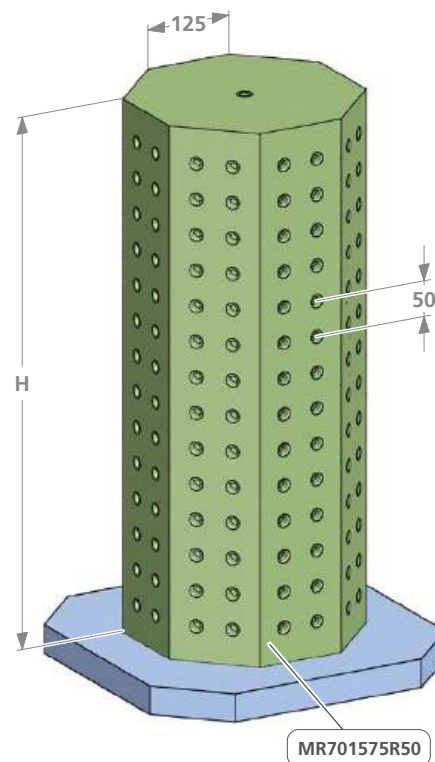

**Mineralgussturm 40-er Raster**  
**Mineral tombstone 40-grid**

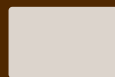

Rechteck  
Rectangle



Quadrat  
Square

**tripoxyMINERAL**

Art. Nr.	kg	Raster / Grid	H
<b>MR633075R40</b>	~314	468 x M12/12F7	750
<b>MR633080R40</b>	~333	494 x M12/12F7	800
<b>MR633090R40</b>	~374	546 x M12/12F7	900
<b>MR633095R40</b>	~393	572 x M12/12F7	950

Auf Anfrage erhältlich  
Available on request

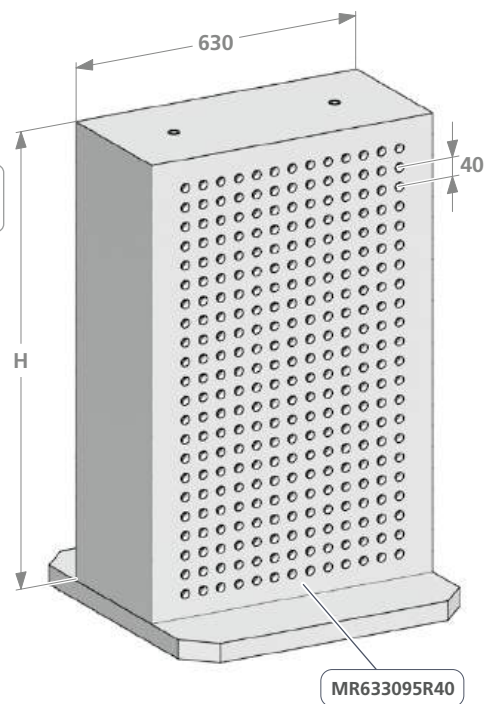

Art. Nr.	kg	Raster / Grid	H
<b>MQ424275R40</b>	~329	612 x M12/12F7	750
<b>MQ424280R40</b>	~349	648 x M12/12F7	800
<b>MQ424285R40</b>	~373	684 x M12/12F7	850
<b>MQ424290R40</b>	~393	720 x M12/12F7	900
<b>MQ424295R40</b>	~413	756 x M12/12F7	950

Auf Anfrage erhältlich  
Available on request

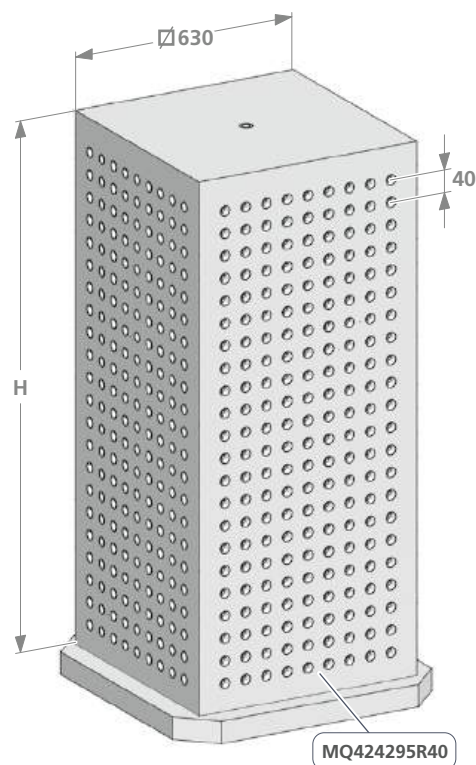

# Mineralgusserhöhung für 5-Achsenmaschinen Epoxy mineral riser for 5-axis machines

**tripoxyMINERAL**

Art. Nr.	kg	H	Raster / Grid R50
<b>MUB2817-H85</b>	~8,7	85	9 x M12/12F7
<b>MUB2817-H100</b>	~10,3	100	
<b>MUB2817-H125</b>	~12,9	125	

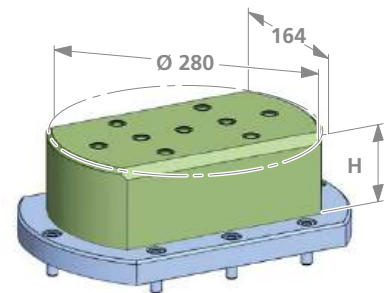

Mineralgusserhöhungen um eine optimale Bearbeitungshöhe und Zugänglichkeit mit der Spindel zu erreichen.

Epoxy mineral risers for an optimal machining height and accessibility with the spindle.



Art. Nr.	kg	Raster / Grid R50
<b>MUB3535H140</b>	~44,1	73 x M12/12F7



Diese Mineralgusserhöhung mit schrägen Basisschienen (PCB50207W27) und einer seitlichen Anordnung weiterer Spannstellen, bietet Ihnen eine Vielzahl an Spannmöglichkeiten.

This epoxy mineral riser with inclined base rails (PCB50207W27) and a lateral arrangement of further clamping points offers you a wide range of clamping possibilities.

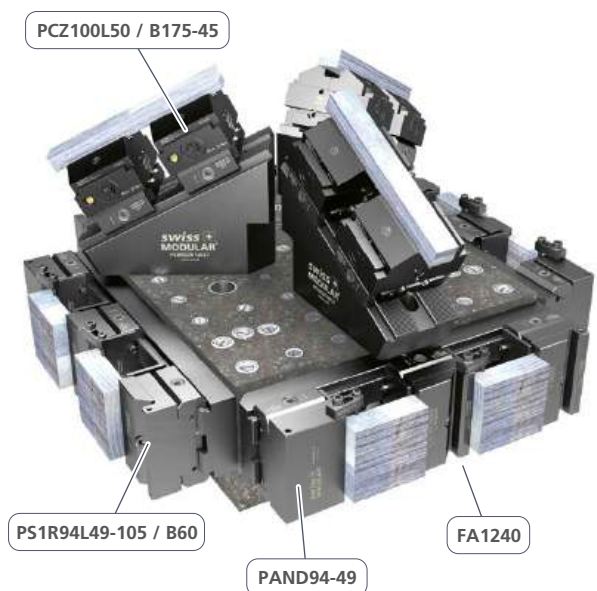
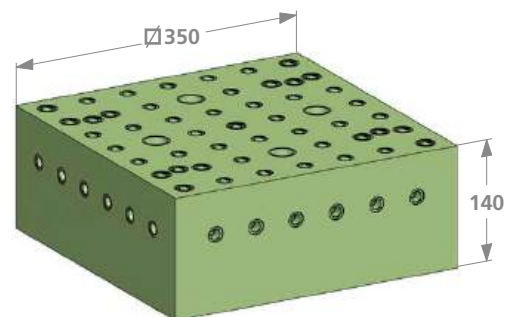

SMK24-24-42 OPP200

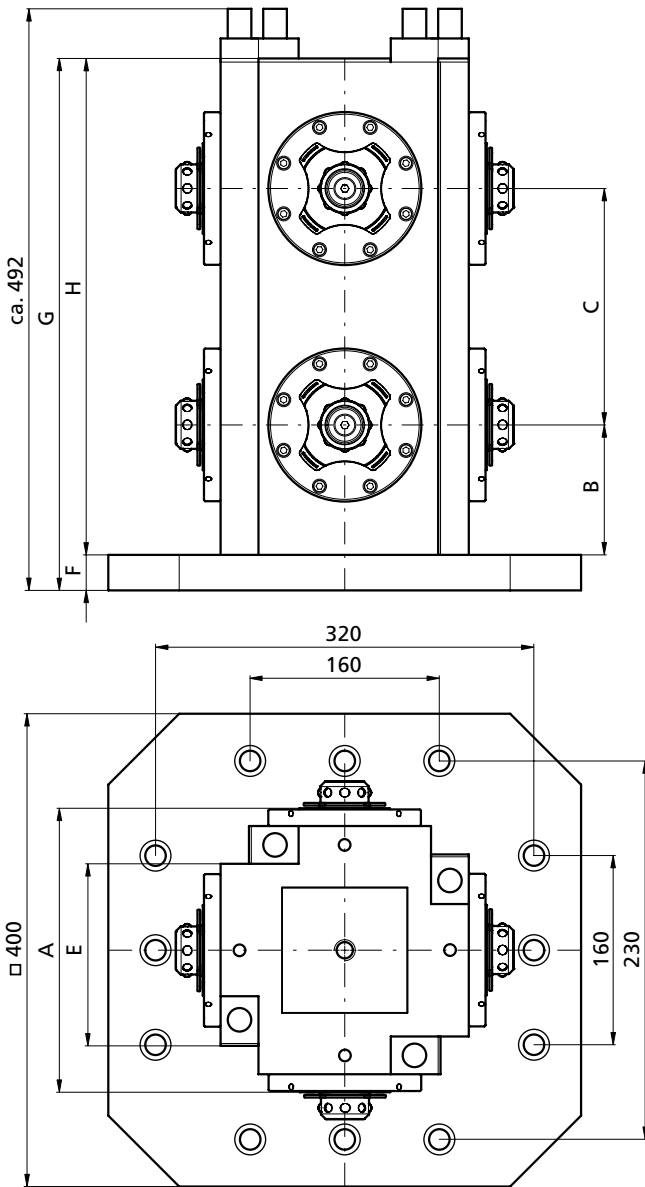

SMK30-17-42 OPP200

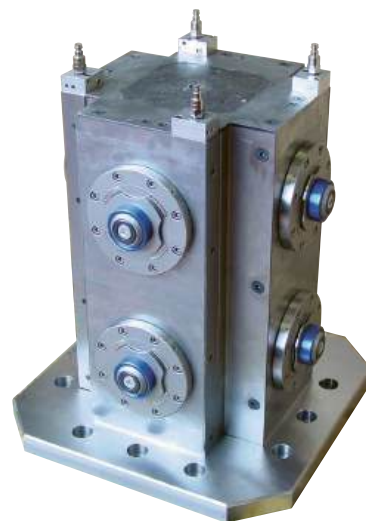
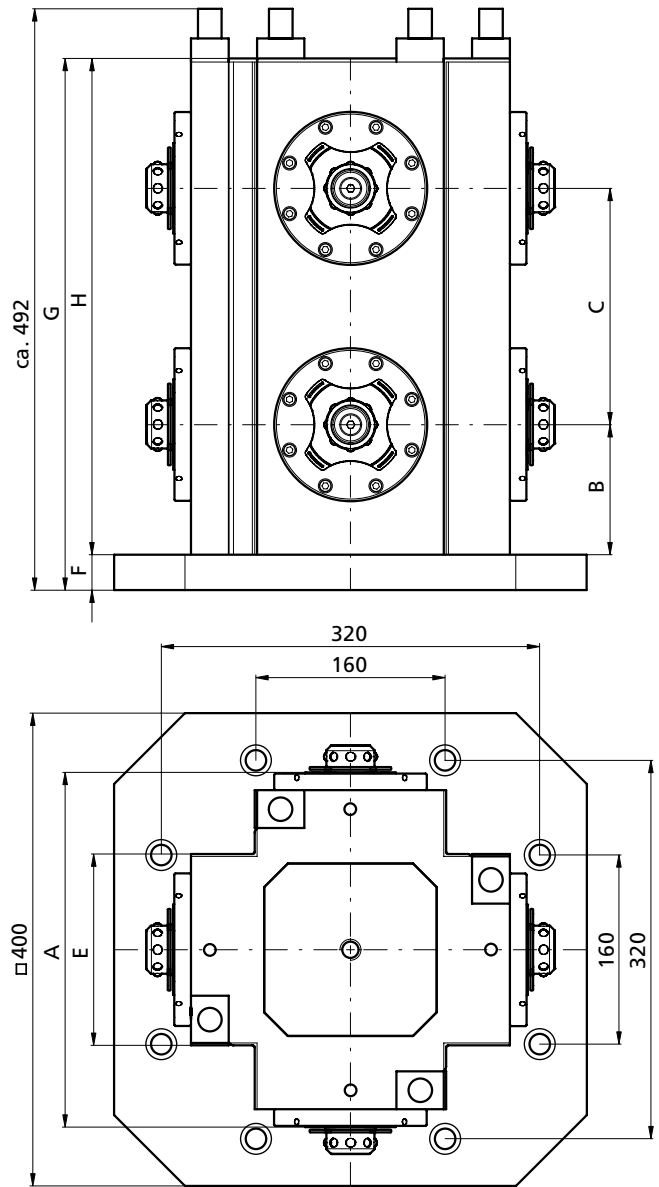

Stahl-Mineralguss

Steel-epoxy mineral tombstones



andere Höhen auf Anfrage  
other heights on request

Seite / Page 250

Bestellbeispiel  
Ordering example: **SMK242442OPP-200**

	kg	A	B	C	E	F	G	H	Raster / Grid
SMK24-24-42OPP200	~120	240	110	200	166	(30)	(450)	420	OPP-200
SMK30-17-42OPP200	~142	300	110	200	166	(30)	(450)	420	OPP-200

# Stahl-Mineralgusstürme

## Steel-epoxy mineral tombstones

tripoxyMINERAL

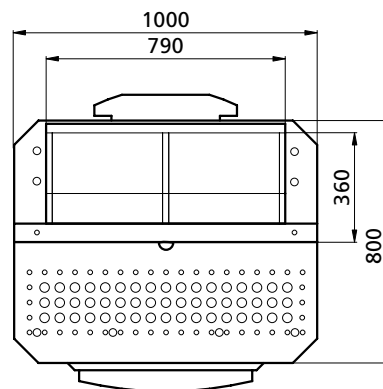
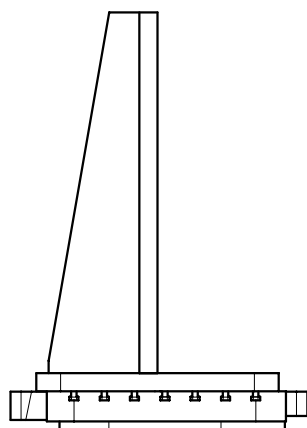
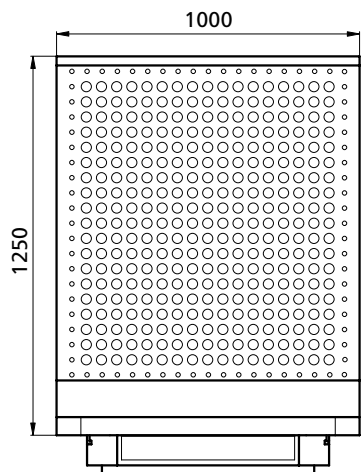

Gesamtgewicht  
Total weight ~1300kg



Epoxy

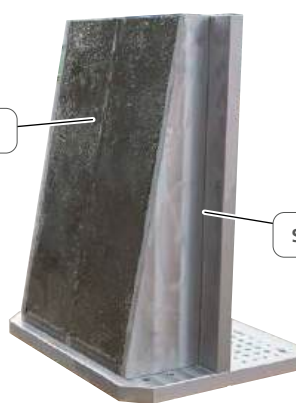

Stahl / Steel



## SPECIALS

Beine aus rostfreiem Stahl oder Holz  
Legs made of stainless steel or wood

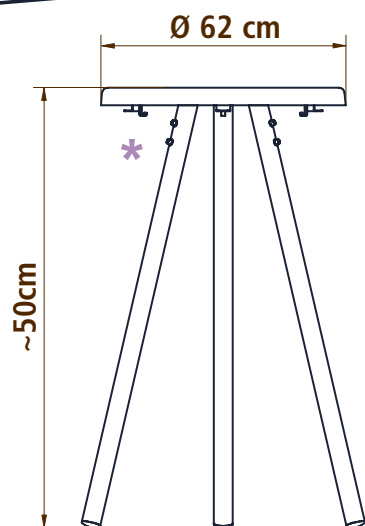

\* Inkl. 3x Flaschenöffner / Kleiderhaken  
Incl. 3x bottle opener / coat hook



Ihr Logo hier  
Your logo here



Salontisch  
Salon table

Jeder Tisch ist ein Unikat  
- Hergestellt aus Schweizer Stein-Granulat

Each table is unique  
- Made from Swiss stone granulate

Art. Nr.

MST-TRI-600

Grundplatten für Mineralgusstürme Base plate for epoxy mineral tombstone	A	B	C	kg
GPL30040	300	300	40	~27
GPL40040	400	400	40	~47
GPL50040	500	500	40	~74
GPL45040	450	450	40	~61
GPL50040040	500	400	40	~58
GPL63040	630	630	40	~120
GPL80040	800	800	40	~195

Rasterplatten Grid plate	A	B	C	Raster / Grid	kg
GPL40040R50	400	400	40	M12/12F7	~48
GPL50040R50	500	500	40	M12/12F7	~74
GPL63040R50	630	630 <td 40	M12/12F7	~119	

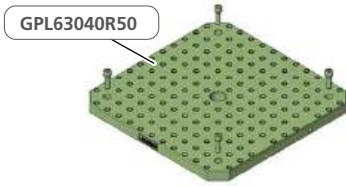

Andere Grössen auf Anfrage  
Other dimensions available on request

Im Lieferumfang: Schrauben zur Befestigung des Turms, ohne Positionierzapfen und Schrauben maschinenseitig.  
The package: Screws for fixing the tombstone, without screws and counter piece to the machine side.

Bohrungen der Grundplatte / Drill holes in the baseplate:  
Kundenspezifisch an die Maschine angepasst  
Made up to customer's specifications

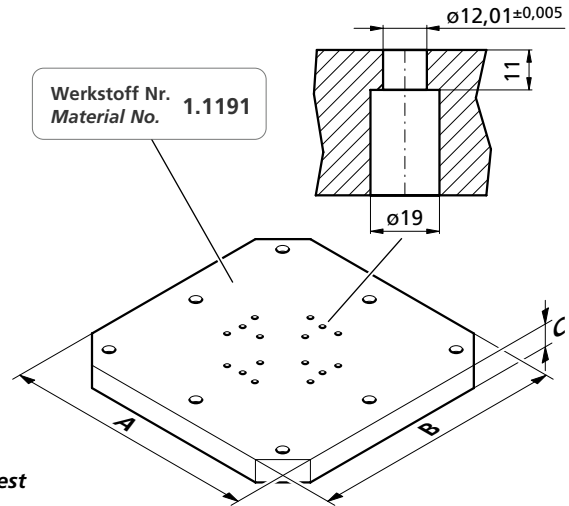

GPL40040-UV  
kg ~40,34

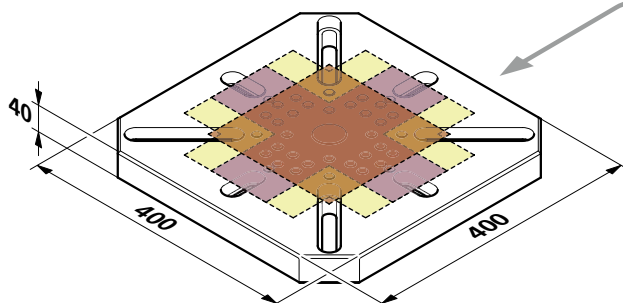
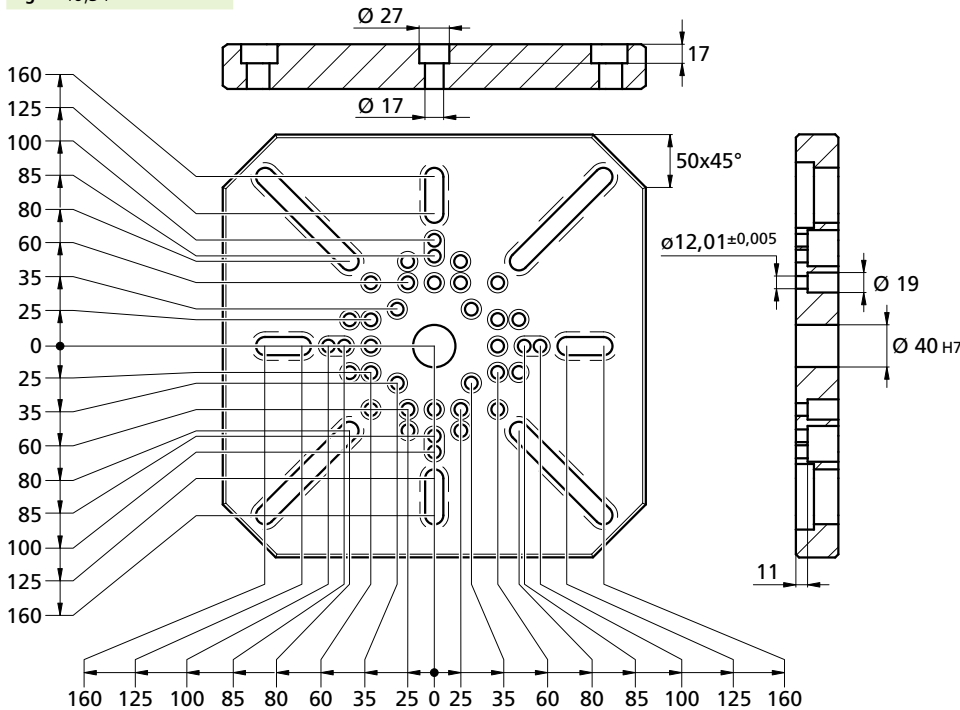

27 verschiedene Mineralgusstürme  
passend zu dieser Grundplatte.  
27 different Epoxy mineral tombstone  
are suitable for this base plate.

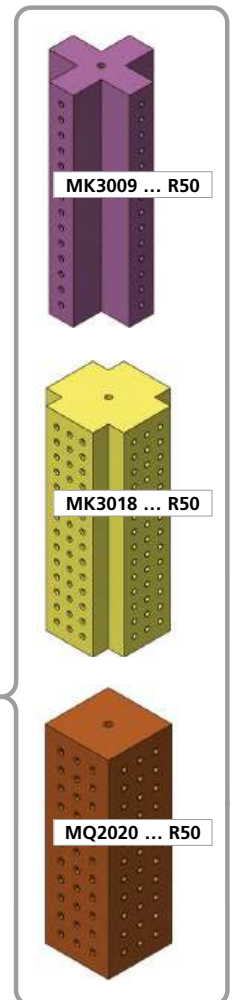

# Abdeckbleche zum Schutz der Oberfläche der Mineralgusstürme Cover plates for surface protection of epoxy mineral tombstones

Art. Nr.

**MABD501550**

**MABD502050**

**MABD502550**

**MABD503050**

**M12X25DIN7984**

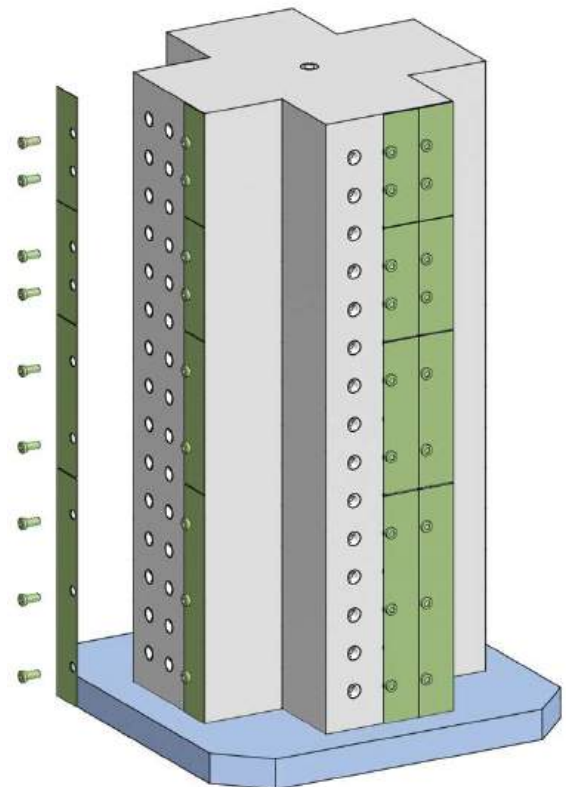
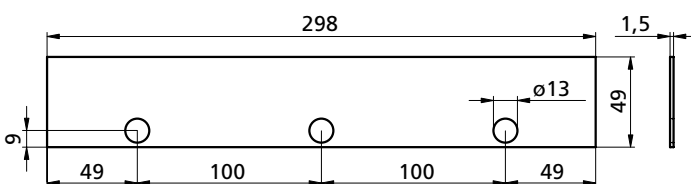
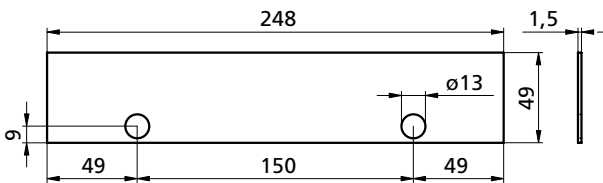
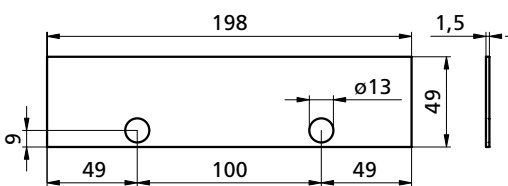
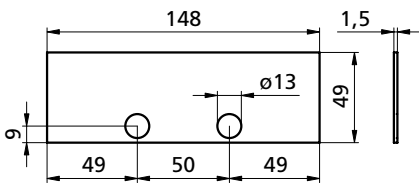
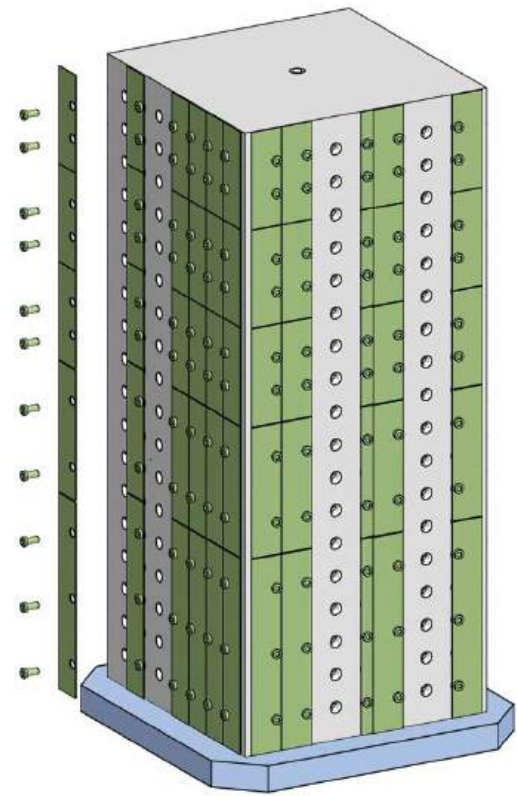
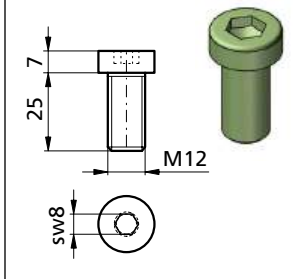

# Stahl Mineralgusserhöhungen

## Steel-epoxy riser

SMUB2373H220

SMUB3373H220

**tripoxyMINERAL**

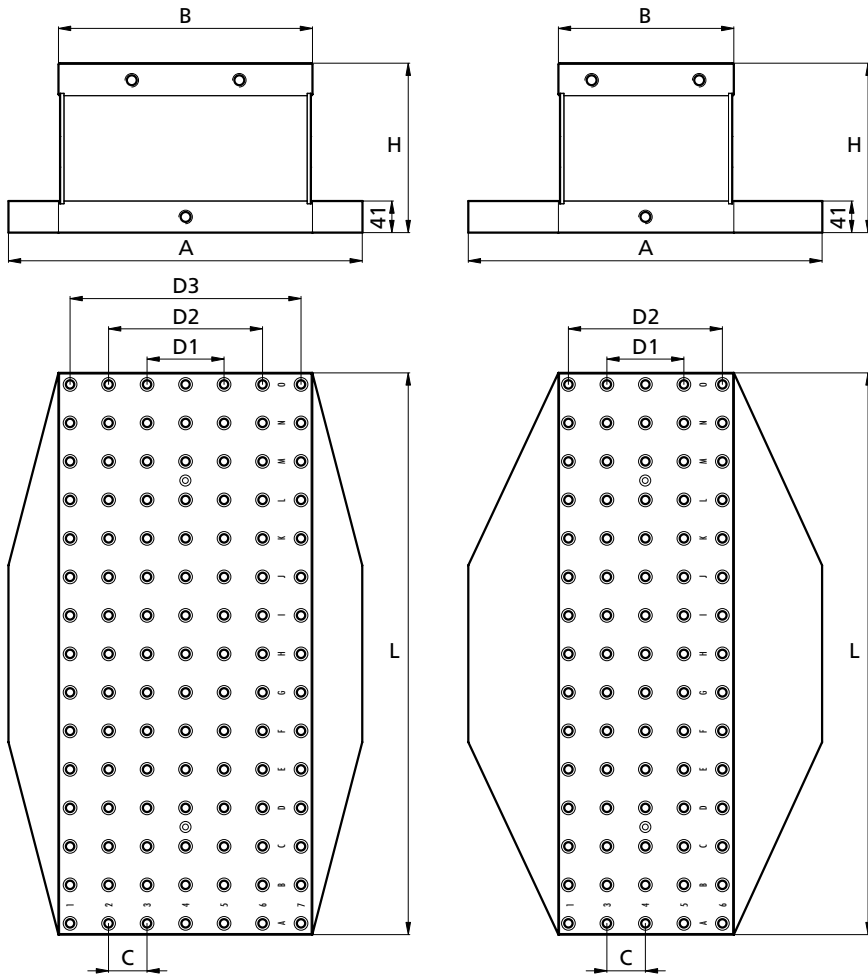

**Entwickelt für die Luftfahrt.  
Gewappnet für höchste Anforderungen.**

Sehr hohe Vibrationsdämpfung dank Kern aus Mineralguss. Hohe Festigkeit dank Ummantelung aus Stahl. Begünstigt die Gewichtsreduktion wodurch die Maschine geschont wird.

Mit integrierten Vakuum Kanälen erhältlich.

**Developed for aviation.  
Prepared for the highest requirements**

Very high vibration damping thanks to epoxy mineral core. High strength thanks to the coat made of steel. Supports weight reduction which protects the machine.

Risers can be made with integrated vacuum channels.

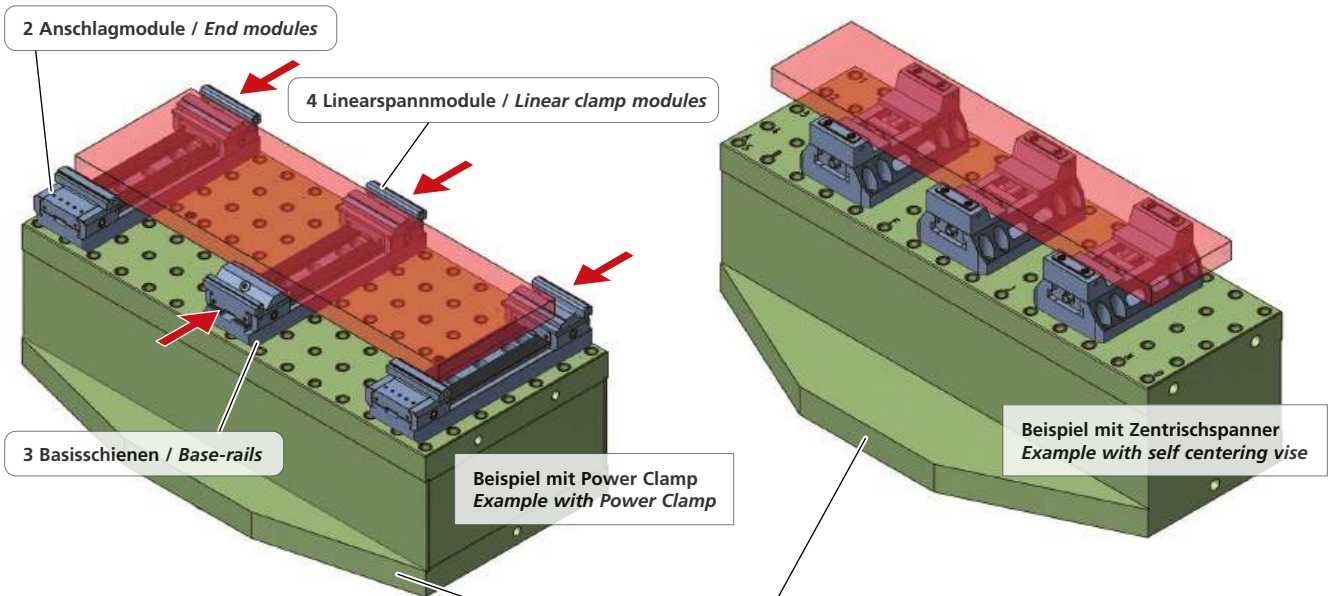

Grundplatte wird passend zu Ihrer Maschinenpalette hergestellt!  
Base plate according to your machine configuration!

Stahl-Mineralguss

Steel-epoxy mineral tombstones

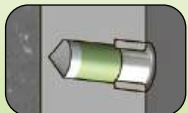

Bestellbeispiel  
Ordering example: **SMUB2373H220**

	kg	A	B	C	D1	D2	D3	H	L	Raster / Grid
SMUB2373H220	~168,0	460	230	50	100	200		220	730	75 x M12/12F7
SMUB3373H220	~214,4	460	330	50	100	200	300	220	730	105 x M12/12F7

Separat bestellen / Order separately

**Stahl Mineralgusserhöhungen mit integriertem Vakuum Anschluss**  
**Steel-epoxy riser with integrated vacuum**

**tripoxyMINERAL**

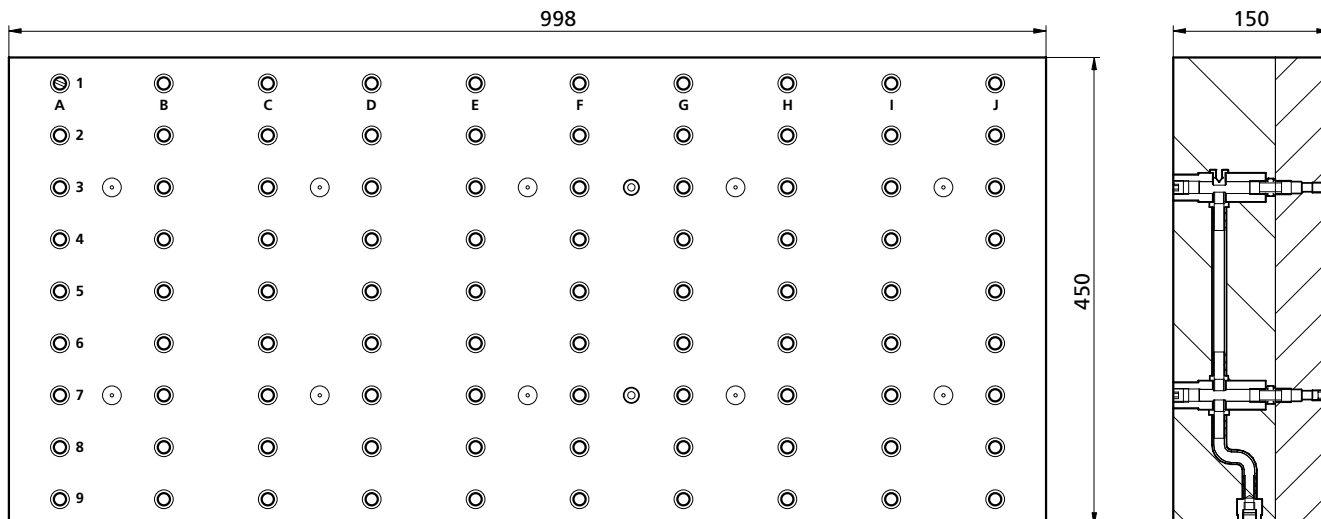

**Stahl-Mineralguss**  
**Steel-epoxy mineral tombstones**

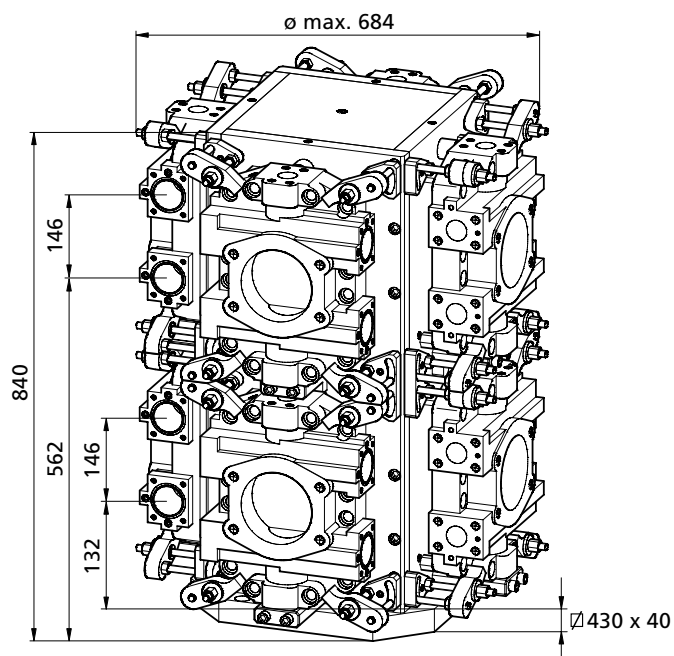

**Gesamtgewicht**  
**Total weight**  
**~600 kg**

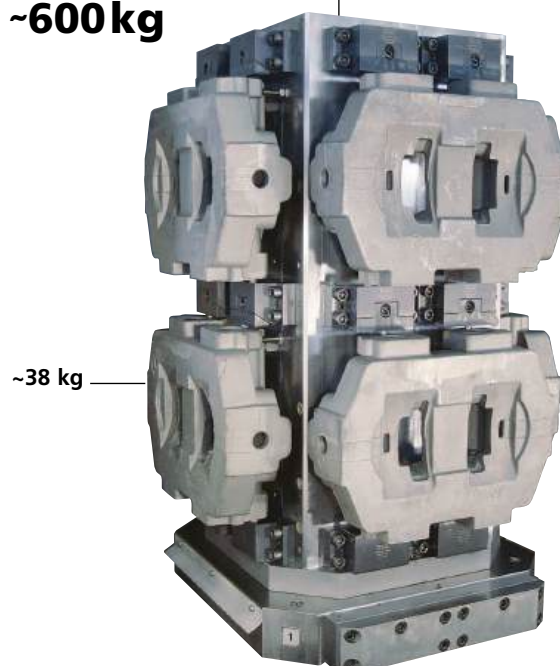

**Balken und Würfel aus Stahl-Mineralguss**  
**Trunion and cubes made from steel epoxy**

**tripoxyMINERAL**

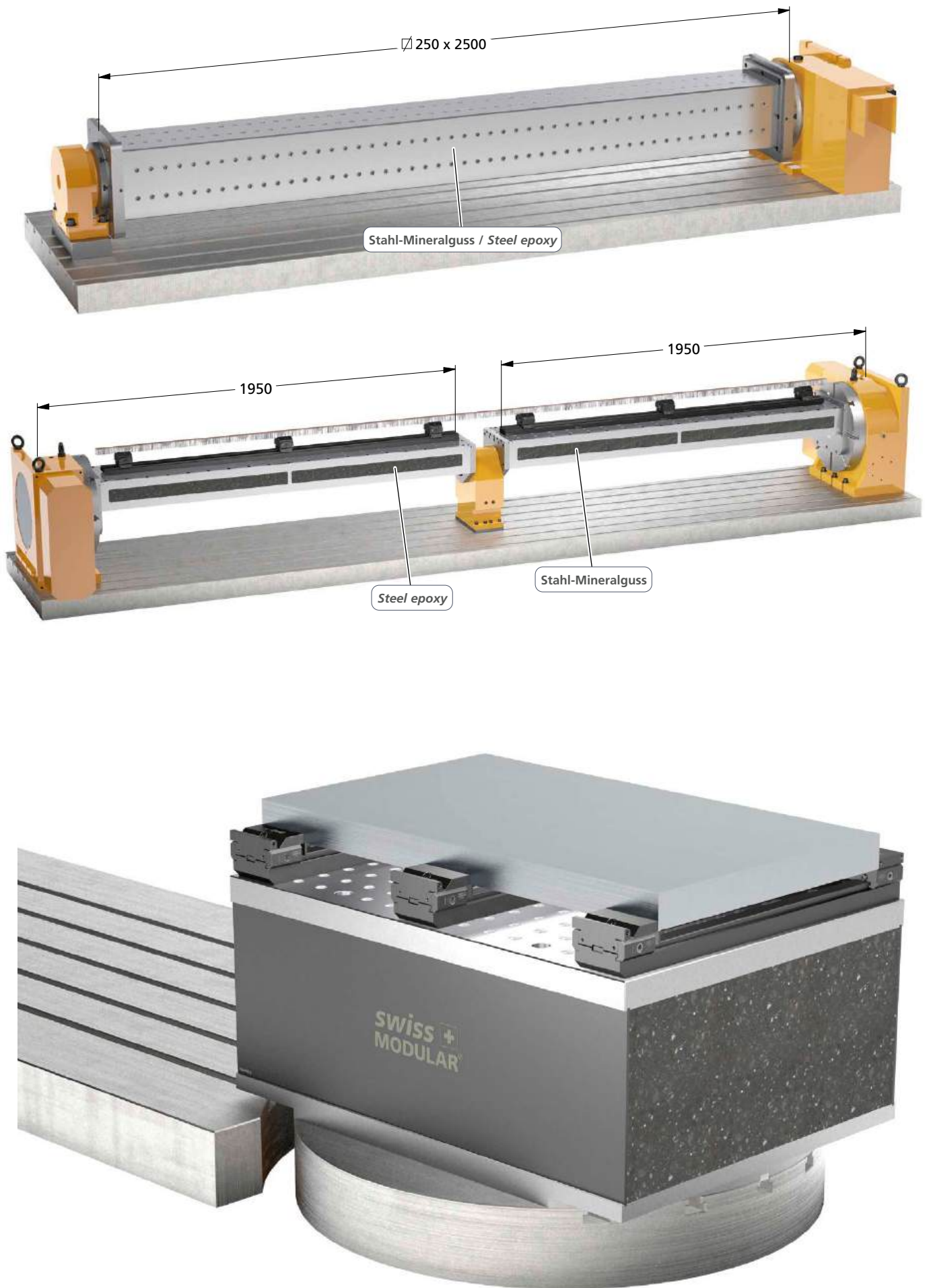

Mineralgusstürme seit  
*Epoxy tombstones since*

1998

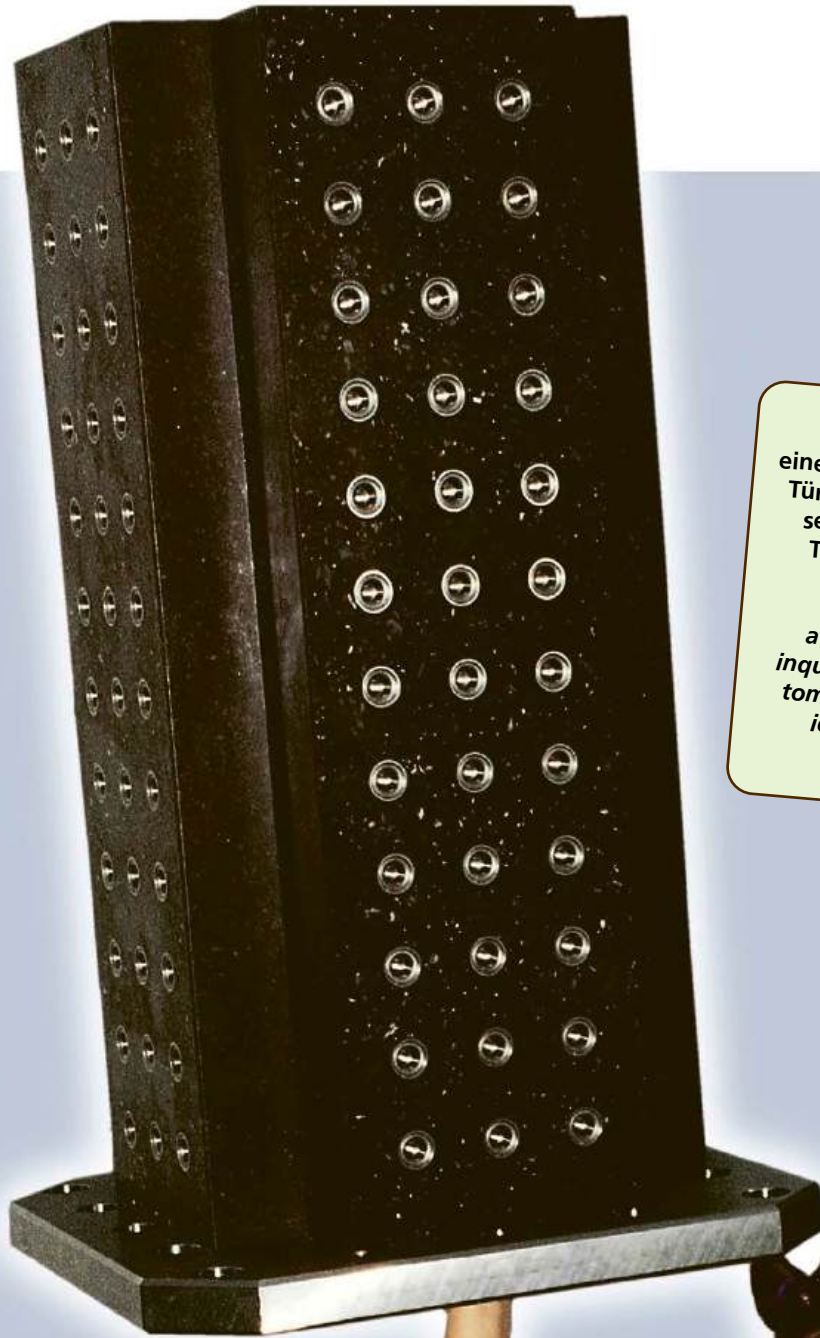

Beat Baumgartner erhält von einem Kunden eine Anfrage für leichte Türme, die aber nicht aus Aluminium sein dürfen. Er hat die Idee, einen Turm aus Mineralguss zu bauen.

*Beat Baumgartner receives a request from a customer who inquires about light, non-aluminium tombstones. He comes up with the idea to build a mineral epoxy tombstone.*





# oppSYSTEM & 5axes

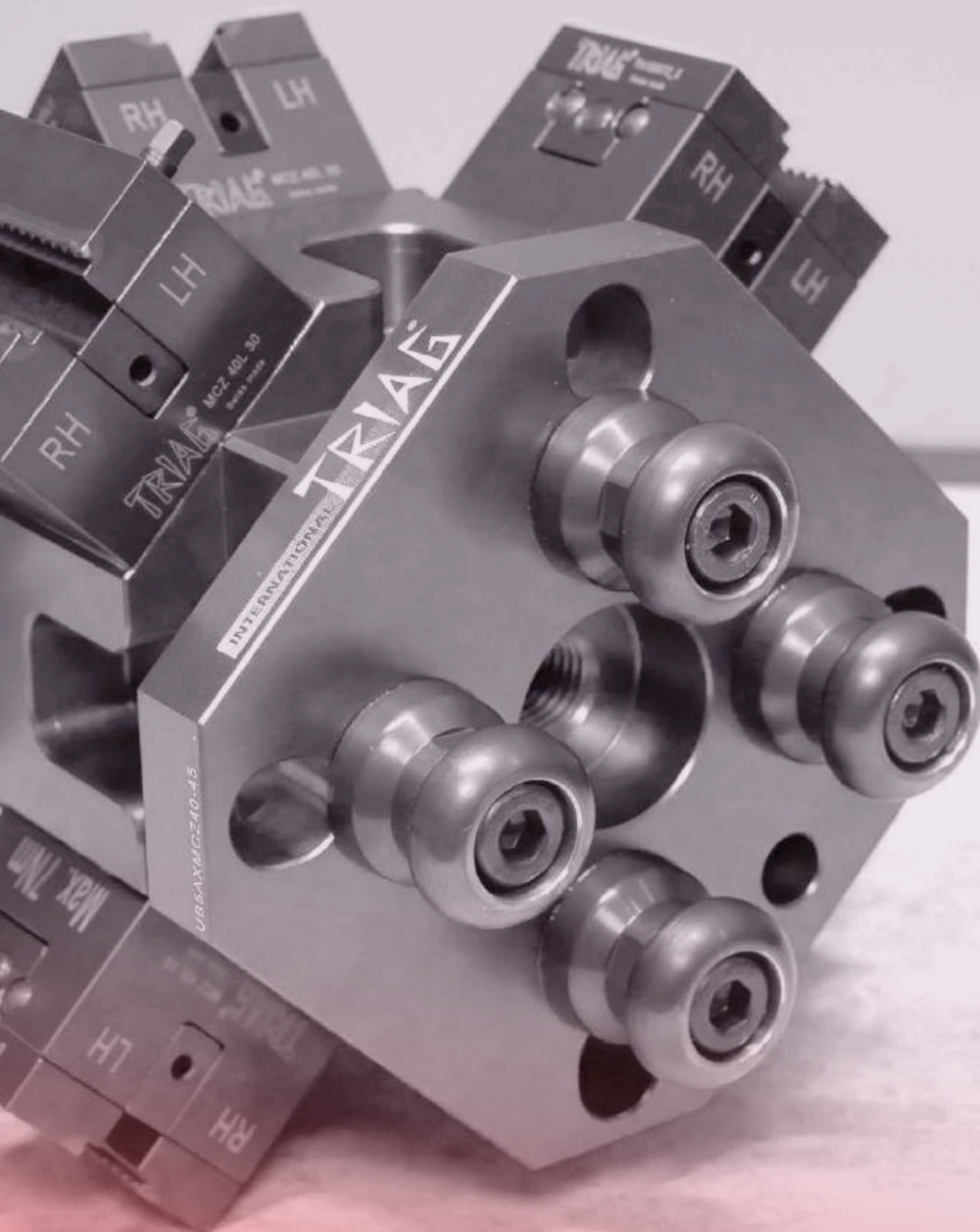



Einleitung | *Introduction* ..... 281 - 283

Anwendungsbeispiele | *Examples of application* ..... 284 - 285

Mechanisches Nullpunktsystem mit diversen Spannlösungen  
*Mechanical zero point system with different workholding solutions* ..... 286

0-Punkt Schnellwechselsystem | *Mechanical zero point system* ..... 287



4-Achs Lösungen für mechanische 0-Punkt Schnellwechselsysteme  
*4-axis solution for mechanical 0-point quick change systems* ..... 288



0-Punkt Erhöhung & Ausrichtplatte  
*Zero point riser & Alignment plate* ..... 289



Dreibackenfutter | *Three-jaw chuck* ..... 290



Klemmbüchse | *Clamping-case* ..... 291



Zentriereinheit | *Chuck unit* ..... 292



Palettenträger | *Receiver chuck with chucks* ..... 293

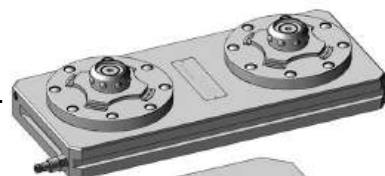

MTS Palettier-System | *MTS palleting system* ..... 297 - 300

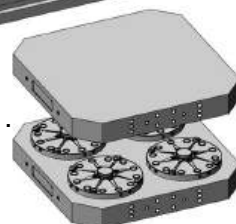

Zubehör | *Accessoires* ..... 301



**Nullpunkt-Palettiersystem**

**Zero-point palleting system**

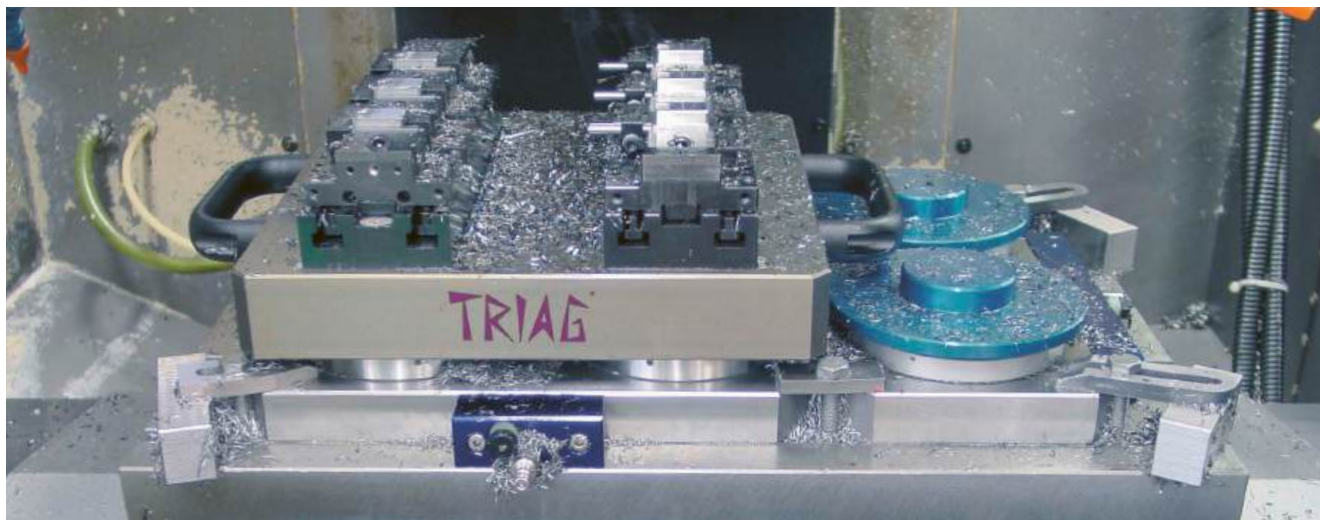

In den letzten Jahren wurden die Werkzeugmaschinen viel leistungsfähiger. Damit wurden die Bearbeitungszeiten wesentlich kürzer. Aufgrund der vom Auftraggeber verlangten Lieferzeiten „just in time“ sind aber die Losgrößen geringer geworden, was zu vermehrten Einrichtzeiten führt.

*The productivity of modern machining centers has been drastically increased over the past years. Hence the time per workpiece is falling. On the contrary the batch sizes are getting smaller due to the increasing trend to „just in time“ production.*

Auch die technisch hochentwickelten Maschinen sind jedoch immer noch mit einem T-Nuten Tisch ausgerüstet. Die Befestigung und das Ausrichten des zu bearbeitenden Werkstückes auf dem T-Nutentisch kann nur während der (teuren) Maschinen-Stillstandszeit erledigt werden. Diese Unproduktivität kumuliert sich, wenn die Werkstückbearbeitung mehrere Maschinenprozesse und somit mehrmaliges Befestigen und Ausrichten erfordert.

*This means that the machine must be set up more frequently. Is the machine not equipped with a pallet changer, the set up and the changing of workpieces may only be accomplished during the stand still of the machine. This idling of the machine results in the loss of costly productive machine time. As it is, the aim of any machining facility to keep the spindle turning, the unproductive time must be minimized. As any machinist knows, the set up and alignment of workpieces on a T-slot table is very awkward and time consuming.*

Die Lösung, die wir Ihnen für dieses Problem bieten, ist unser neuartiges, modulares Palettiersystem, das oppSystem.

*The TRIAG opp (Zero-Point-Palleting) System represents an ideal interface between machining table and workholding device.*



Das System besteht aus dem auf dem Maschinentisch der Werkzeugmaschine montierten Palettenträger und mindestens zwei Paletten oder mit Zentrier- und Klemmbüchsen ausgerüsteten Werkstückträgern. Die sehr präzise gefertigte Schnittstelle zwischen dem Palettenträger und der Palette ermöglicht ein sekundenschnelles Ein- und Auswechseln der Paletten, auf welcher ausserhalb der Werkzeugmaschine das zu bearbeitende Werkstück montiert und positioniert wird. Es wird eine sehr hohe Ausnutzung der theoretisch zur Verfügung stehenden Maschinenlaufzeit erreicht. Dies erhöht die Produktivität der Maschine und damit die Wirtschaftlichkeit des ganzen Betriebes.

Im Gegensatz zu vielen anderen Palettiersystemen auf dem Markt ist die Dimension des oppSystems in Form von Stichmassen genormt und richtet sich damit nach den individuellen Werkstückdimensionen. Die patentierte Konstruktion erlaubt überdies auch die unbemannte Be- und Entladung mit Hilfe eines Beschickungsgerätes.

Mit dem oppSystem sind 750'000 Spannungen ohne Referenzverlust möglich, bei einer Repetiergenauigkeit von  $\pm 0,002$  mm. Das Lösen erfolgt pneumatisch mit ca. 6 bar, womit keine Mehrkosten für Hydraulikaggregate entstehen. Eine allfällig entstehende Wärmeausdehnung wird über die federnde Zentrierung kompensiert. Alle wichtigen Bauteile sind wartungsarm, leicht zu überprüfen und im Bedarfsfall einfach auszutauschen.

*On the machine table the receiver chuck is installed. This chuck may consist of one, two, four, six or more receiver units. Onto these air operated receiver chucks a pallet, a fixture or a vice is mounted within a matter of seconds. On the bottom surface of the workholding devices centering rings are inserted. These centering rings are ground to a very high accuracy permitting the locking down of the workholding device with a repeatability of  $\pm 0.002$  mm on all three axes. The chucks are locked by spring force and unlocked by compressed air of 6 bar. This means that no hose connection is necessary during machining. Hydraulic pumps or hydraulic amplifiers are superfluous.*

*The patented oppSystem allows for 750'000 locking and unlocking cycles without loss of positioning accuracy. If necessary, the changing of the pallet may be accomplished by a robot or a handling system. Thermal expansion is compensated for by the spring loaded centering units.*

*Due to the unique oppSystem it is possible to bring the loading and unloading of the actual workpiece out of the machine which guarantees a maximum of productive machine time. Maintenance is simple as all components are easily accessible and replaceable. There are standard receiver chucks and pallets available with two or four receiver units. For other solutions or dedicated fixture you should contact TRIAG or your nearest dealer.*

SMK30-17-42 OPP200 ~ 142 kg

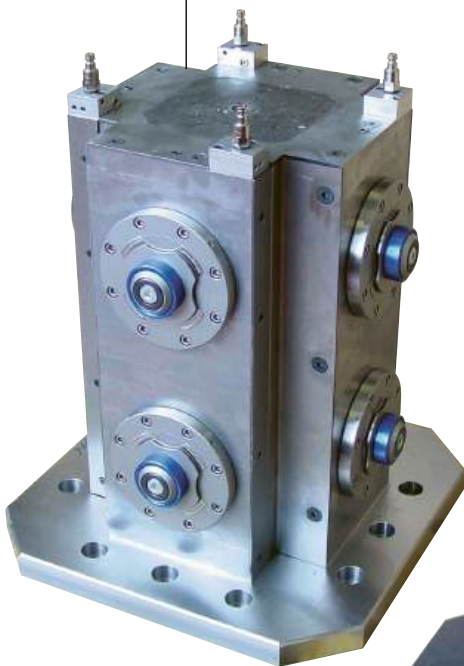

SMK24-24-42 OPP200 ~ 120 kg

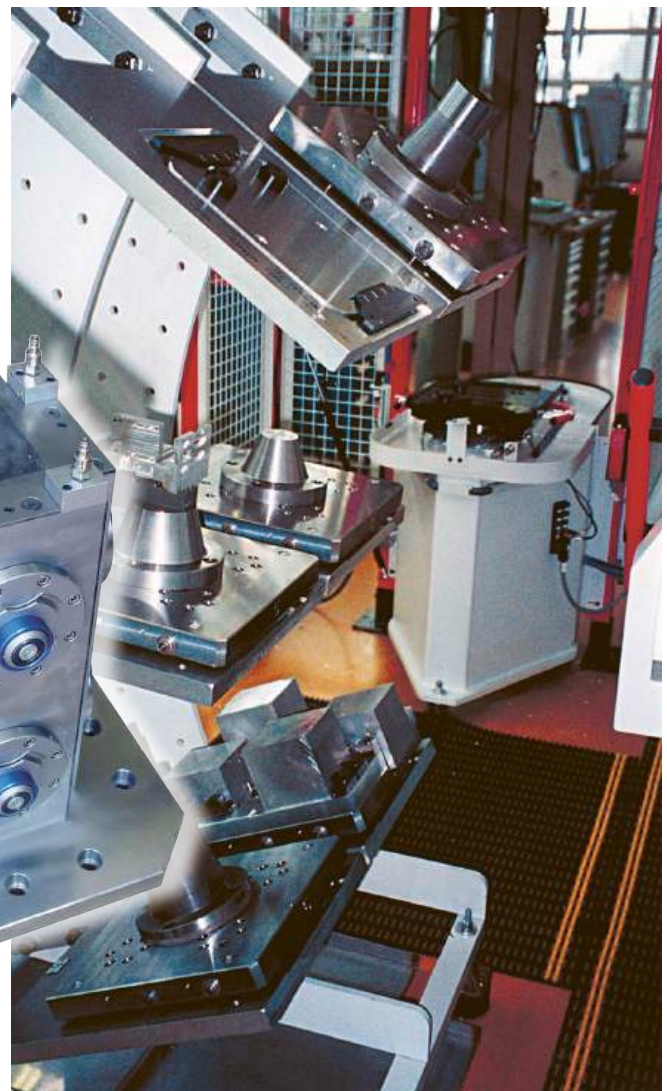
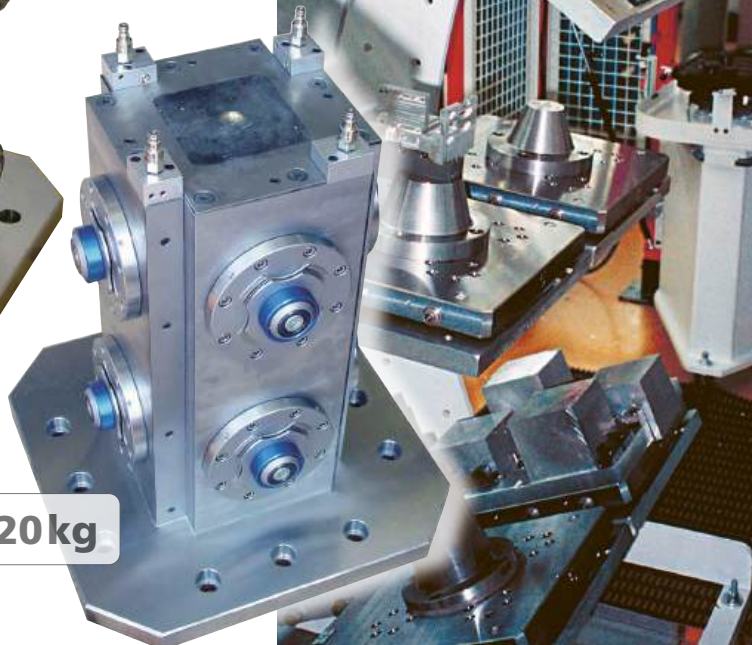

Mehr Informationen siehe Triproxy Mineral  
For more information check the Triproxy Mineral p. 271

**Nullpunkt-System OPP & Erowa MTS**

In Verbindung mit dem Spannsystem powerCLAMP bilden die Nullpunkt-Paletten oppSysteme sehr kompakte, hochgenaue und schnell wechselbare Spannvorrichtungseinheiten.

**Zentrischspanner mit OPP-Anschluss**

Das neue mechanische 0-Punktsystem (**OPBM4Q100R50**) findet seine Einsatzmöglichkeiten in allen Bereichen.

Von der einfachen Schnellwechselpalette zur Einzelteilmontage bis hin zur Mehrfachspannung in modernen Fräszentren.

Dank der hohen Wiederholgenauigkeit lassen sich Grossserien problemlos und in höchster Genauigkeit fertigen.

**Zero-point system OPP & Erowa MTS**

*Together the modular system with zero point pallets, give a great performance! Fast changing and accurate!*

**Self centering vise with integrated zero point adaptation OPP**

*Because of its compact build body this self centering vise gives a perfect performance to automated 5 axis machines!*

*The index zero point system is built into the body of the vise, a sub pallet as you normally mount the vises!*

*The OPP system is a very accurate system reliable and durable! We guarantee 150'000 changes within  $\pm 0,002\text{mm}$*

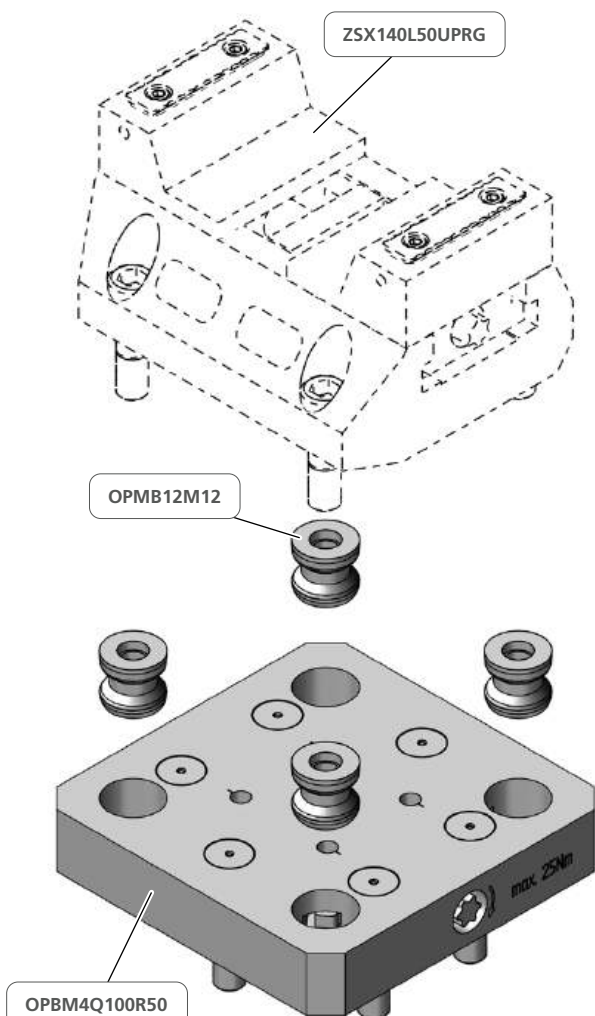



HORIZONTAL





**6** PowerCLAMP Basisschiene mit microCLAMP Vorrichtung. Automatisiert mit Erowa Roboter.  
*PowerCLAMP baserail with microCLAMP. Automated with Erowa Robot.*

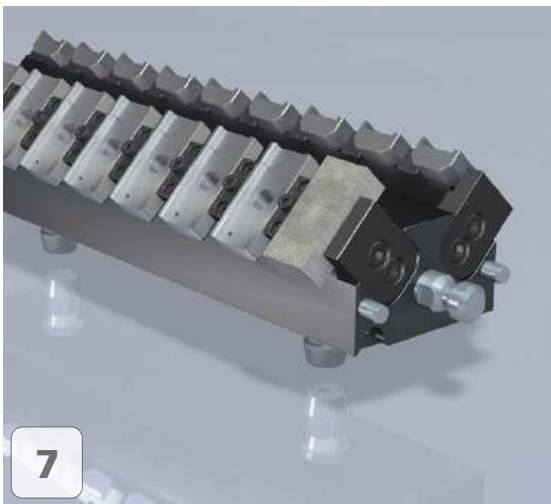

**7**

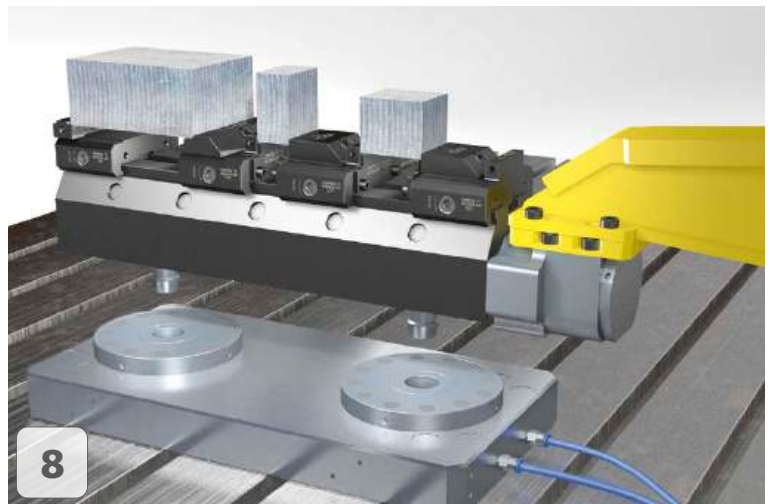

**8**

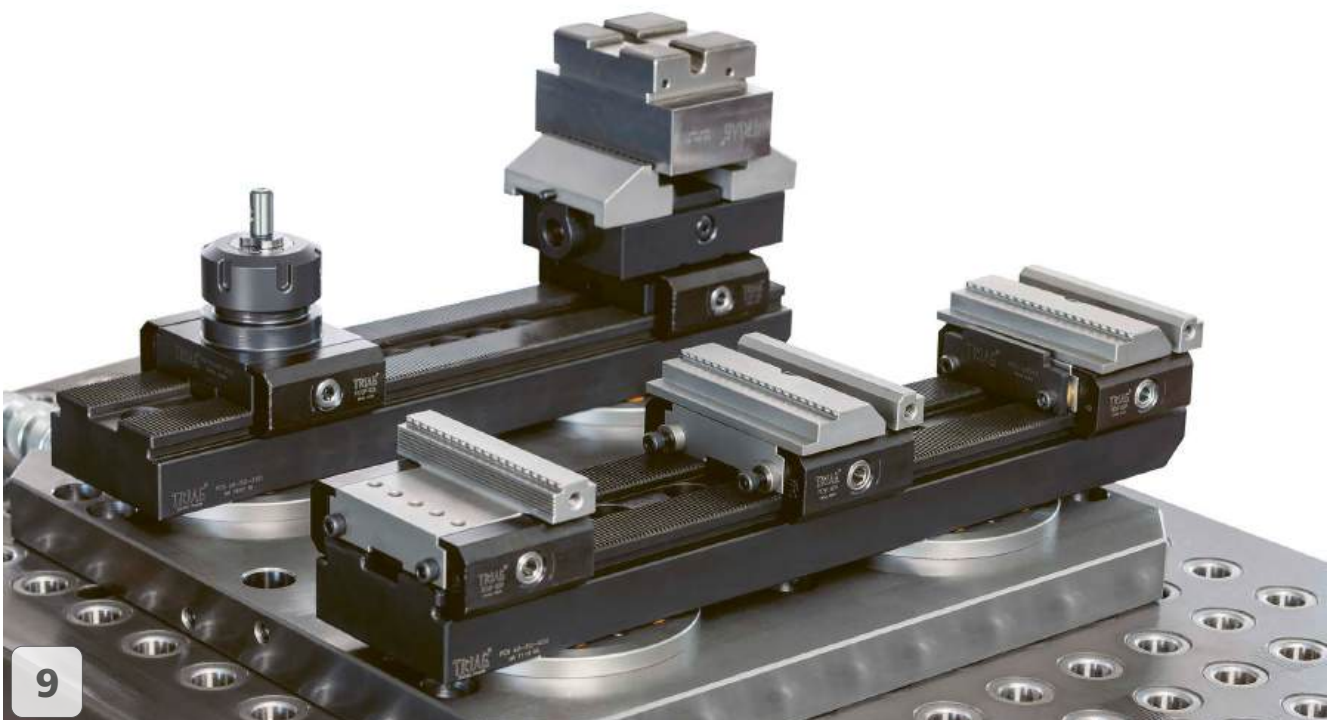

**9**

# Mechanisches Nullpunktsystem mit diversen Spannlösungen

## Mechanical zero point system with different workholding solutions

Da die Anforderungen an „just in time“ Produktion in den letzten Jahren stetig gewachsen sind, ist ein modulares Nullpunkt Schnellwechselsystem der richtige Weg um lange Standzeiten der Werkzeugmaschine zu verhindern.

Since the requirements for „just in time“ production have grown steadily in the recent years, a modular zero-point quick-change system is the right way to prevent long down time of a machine.

- ✓ **Sehr tiefe Bauhöhe (28 mm)**
- ✓ **Wiederholgenauigkeit 0.01 mm**
- ✓ **6000 dAN Haltekraft**
- ✓ **Abhebefunktion ein- und ausschaltbar (3-4 mm)**

- ✓ **Very low height (28mm)**
- ✓ **Repeat accuracy of 0.01mm**
- ✓ **6000daN holding force**
- ✓ **Lift-off function can be switched on and off (3-4 mm)**

**triCENTRO p. 141**

Erhältlich in 3 versch. Größen  
Available in 3 sizes  
Ø 80 / 100 / 125

4x TWPAS1227

4x TWPAS1240

250x80x35

220x80x35

250x150x40

148x148x4

150x150x44

**triCENTRO p. 119**

140x120x83  
Erhältlich in 4 versch. Größen  
Available in 4 sizes  
140x120x83 / 160x120x83  
180x120x83 / 200x120x83

Ø176, H=129

250x80x35

2x TWPAS1227

2x TWPAS1240

250x150x28  
R100/M12/12F7

**A**

150x150x28

**B**

172x172x28

**C**

Ø184x28

**D**

235x235x25

0-Punkt Basis / 0-point base		kg
A	OPBM4Q100R50	~3,8
B	OPBM4Q100R200	~7,6
C	OPBM4Q100D184	~7,6
D	ZF211785	~7,6

Zentrischspanner Self centering vise		Spannbereich Clamping area	kg
2	ZSX140L50UPRG-OPM	62-118	~7,1
	ZSX160L50UPRG-OPM	62-138	~7,7
	ZSX180L50UPRG-OPM	62-158	~8,1
	ZSX200L50UPRG-OPM	62-178	~8,8

spaceGRIP I		kg
3	UB5AXMCZ4045SET8-OPBM	~6,2

PowerCLAMP Set		kg
4	PCSET18250-OPM	
	1x PCSET18-250A / O3	~5,9
	2x PCSET18-L1 / B48-20	~2,65

Basisschiene diagonal / Baserail diagonal		kg
5	PCSET18220W2-OPM	~8,2

PC Schiene / PC Rail 250 mm		kg
6	PCB2550250-OPM	~4,8

Abdeckung / Cover		kg
7	OPMAD	~0,8

Erhöhung / Raiser block		kg
8	OPUB150H44	~8,5

Rasterplatte / Grid plate		kg
9	OPM25-15R50H28	~7,7

Aluminiumplatte / Aluminium plate		kg
10	OPM25-15RH40	~4,3

**p. 287**

Art. Nr.	kg
<b>OPBM4Q100R200</b>	~4,3

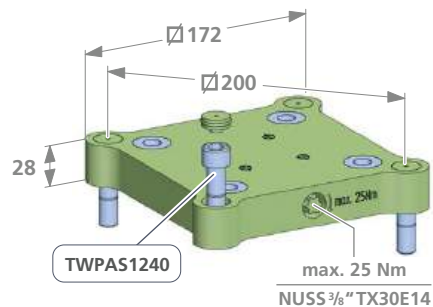

Art. Nr.	kg
<b>OPBM4Q100D184</b>	~4,7

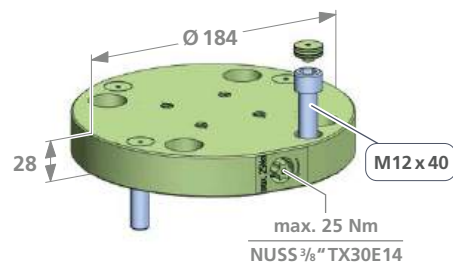

Art. Nr.	kg
<b>OPBM4Q100R50</b>	~3,8

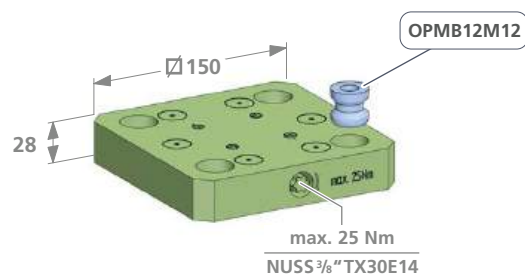

### Positionier-Flansch Positioning-flange

Art. Nr.	A	Ø	kg
<b>ZF211785</b>	235	250	~7,6
<b>ZF222333</b>	172	180	~3,7

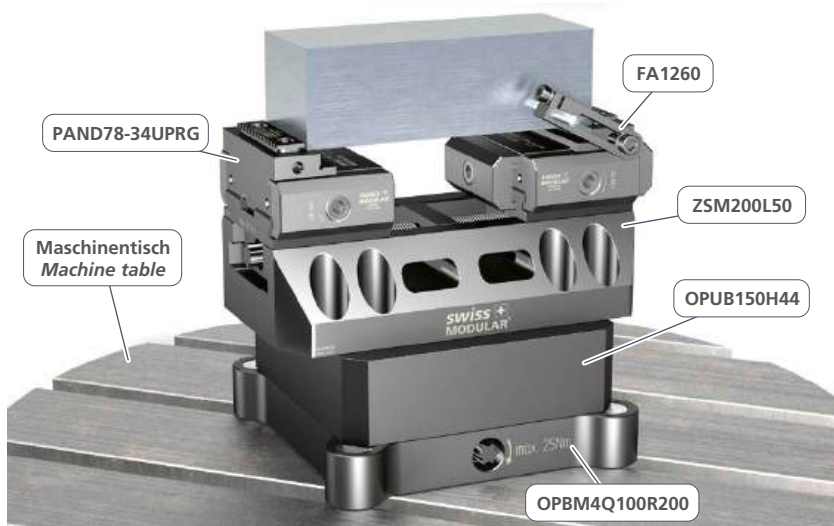
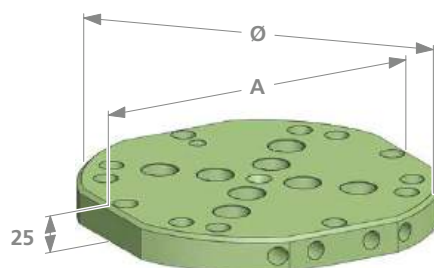

Die Verbindung zwischen Maschinentisch und dem opp-Schnellwechselsystem  
The connection between the machine table and the opp-quick-change system

# 4-Achs Lösung für mechanische 0-Punkt Schnellwechselsysteme

## 4-axis solution for mechanical 0-point quick change systems

**oppSystem**

Winkel für die 4-Achse  
Angle for the 4-axis

Art. Nr.	Y	kg
<b>WU-18</b>	180	~14,1
<b>WU-25</b>	244	~16

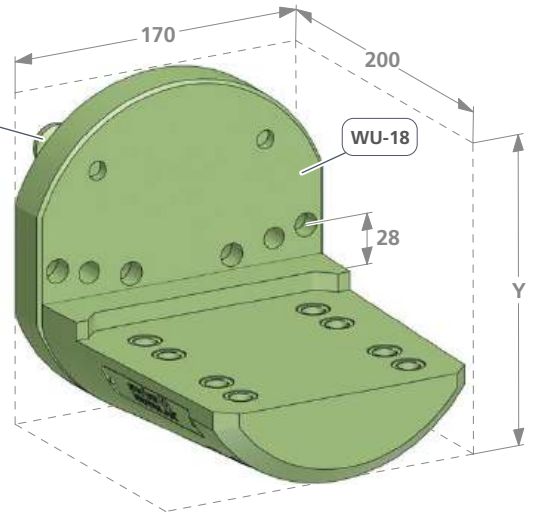
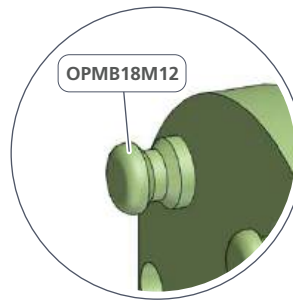

Flansch / Flange  
Optional erhältlich  
Optional accessory

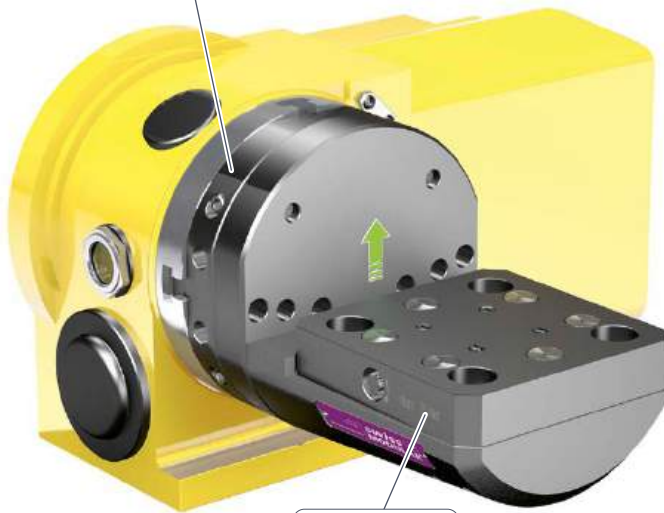

OPBM4Q100R50

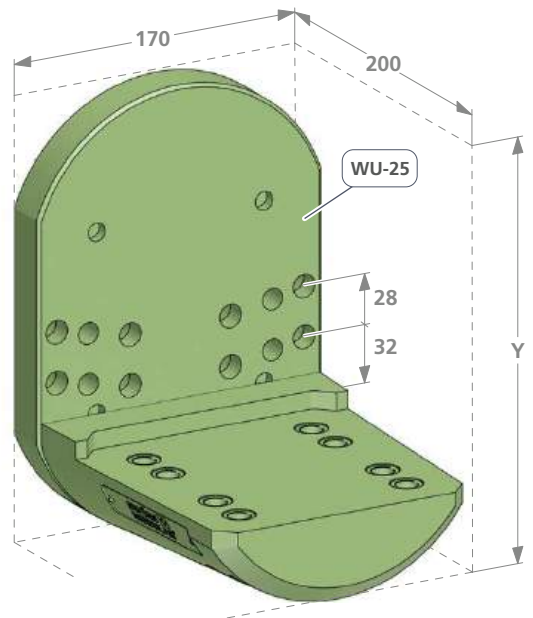

ZSX140L50UPRG

Bei diesen Winkeln kann die Brücke für die Aufnahme der Spannmittel inklusive Werkstücke in der Höhe angepasst werden.

With these angles, the bridge can be adjusted in height to accommodate the clamping devices including workpieces.

# 0-Punkt Erhöhung & Ausrichtplatte

## Zero point riser & Alignment plate

### 0-Punkt Erhöhung Zero point riser

Art. Nr.	kg	
<b>OPUB150H44</b>	~8,5	

Optimal kombinierbar mit der Erhöhung (OPUB150H44) für eine bessere Zugänglichkeit zum Werkstück.

Ideally combined with the riser (OPUB150H44) for better access to work piece.

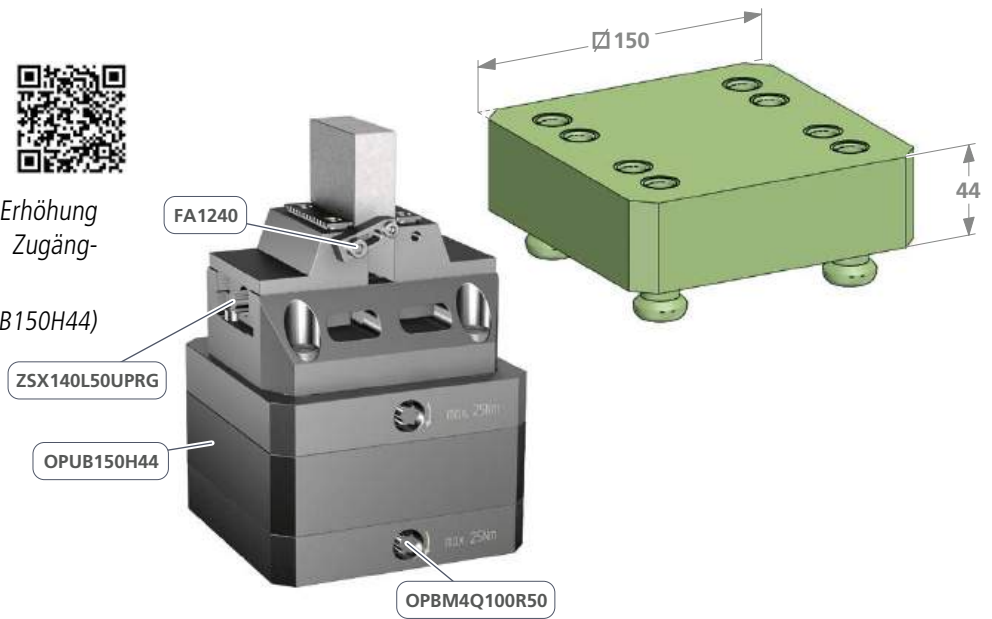





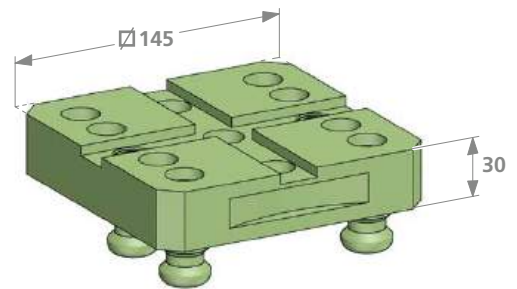

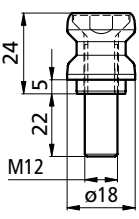
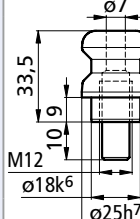
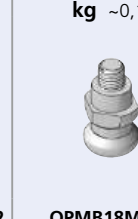
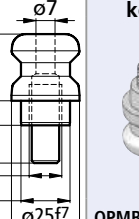

### Ausrichtplatte Alignment plate

Art. Nr.	kg
<b>OPMAW</b>	~3,54

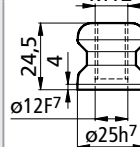

Diese Platte dient zum Ausrichten auf dem T-Nutentisch.

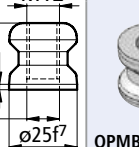
This plate is used to align on the T-slot table.

Nullpunkt Zentrier- und Klemmbolzen Zero point pull studs		Nullpunkt Schwertbolzen Diamond pull studs		Klemmbolzen mit Untermass Pull studs with minus tolerance		Schutzbolzen Protection bolts					
	kg ~0,09		kg ~0,1		kg ~0,1		kg ~0,1		kg ~0,08		kg ~0,07
OPMB18M12L		OPMB18M12		OPMB18M12S		OPMB18M12U		OPMBL		OPMBL-25	
Zentrierbolzen für / Centring pin for PC(M)T & MUB p. 53 - 270 	PDF / STEP		kg ~0,06		kg ~0,06		kg ~0,06				
		OPMB12M12		OPMB12M12S		OPMB12M12U		ORø20x2mm		ORø20x2mm	

**Dreibackenfutter**  
**Three-jaw chuck**

**OPM3X80L75**  
**OPM3X100L82**  
**OPM3X125L88**

**oppSystem**

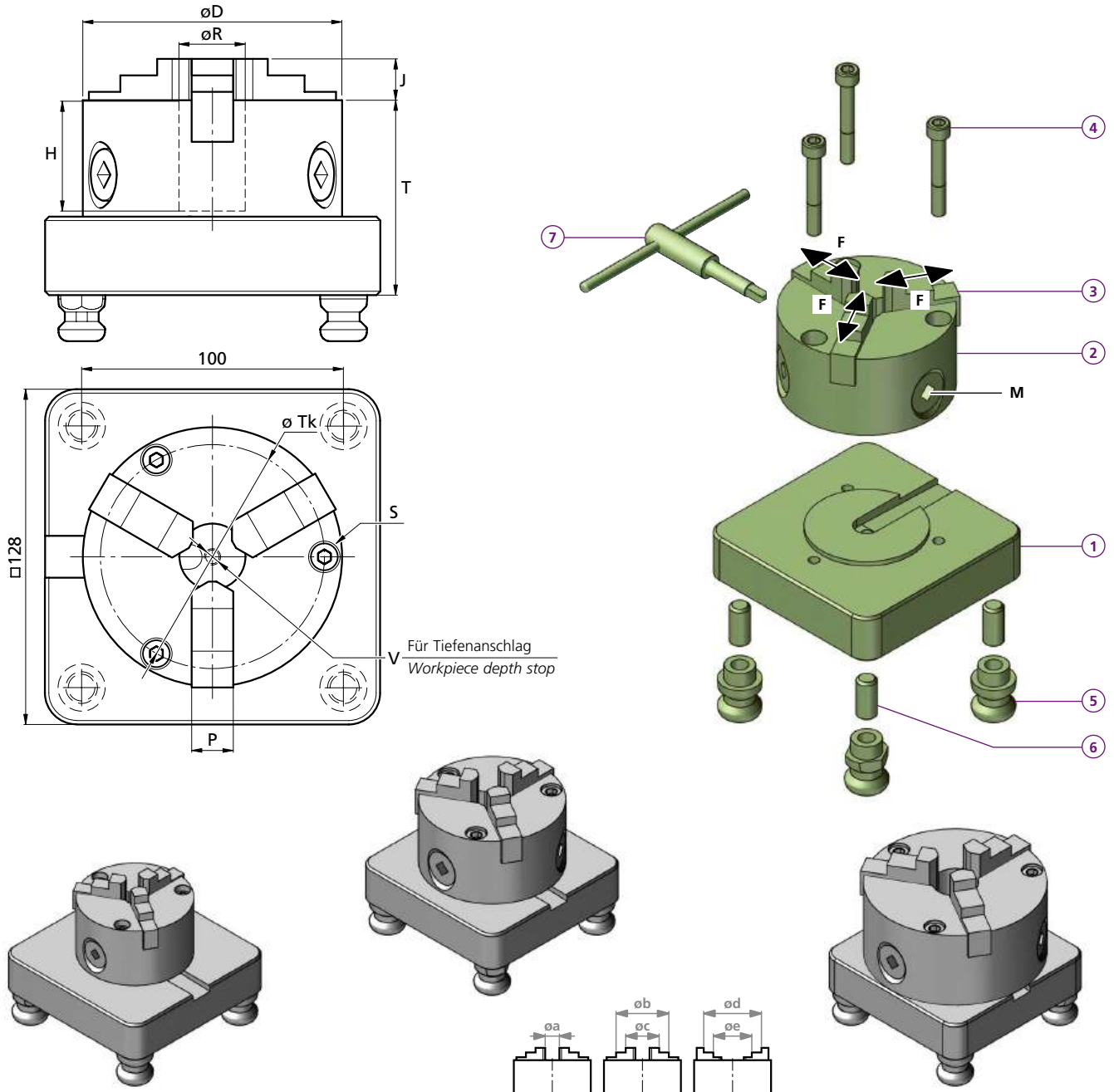

	D	J	T	R	H	P	V	a mm	b mm	c mm	d mm	e mm	M (max.)	F (max.)	$\varnothing Tk$	S
<b>OPM3X80L75</b>	80	13	75	15	42,5	10	M6	3...27	48...73	23...48	52...76	27...51	28 Nm	1300 daN	67	M6
<b>OPM3X100L82</b>	100	17	82	20	49,5	14	M8	3...39	58...94	24...60	64...100	30...66	38 Nm	1600 daN	83	M8
<b>OPM3X125L88</b>	125	19	88	32	55	16	M8	3...49	70...116	30...75	83...125	38...84	55 Nm	2600 daN	108	M8

	<b>OPM3X80L75</b>	<b>OPM3X100L82</b>	<b>OPM3X125L88</b>
1	1x TB161207	1x TB161208	1x TB161209
2	1x 243809.0083220	1x 243809.0103220	1x 243809.0123220
3	2x 3 Stk. / pcs	2x 3 Stk. / pcs	2x 3 Stk. / pcs
4	3x TN100346	3x TN100360	3x TN100361
5	1x OPMB18M12	1x OPMB18M12	1x OPMB18M12
	2x OPMB18M12U	2x OPMB18M12U	2x OPMB18M12U
	1x OPMB18M12S	1x OPMB18M12S	1x OPMB18M12S
6	4x TN100067	4x TN100067	4x TN100067
7	1x 243864.0080000	1x 243864.0100000	1x 243864.0120000
kg	~ 5,8	~ 7,3	~ 9,5

243849.0083200  
243849.0103200  
243849.0123200

3x  
 $\varnothing 3 - 49$

243850.0083200  
243850.0103200  
243850.0123200

3x  
 $\varnothing 38 - 125$

\*243834.0083300  
\*243834.0103300  
\*243834.0123300

3x  
\*Weich  
Soft  
16MnCr5

Separat bestellen / Order separately

Bestellbeispiel / Ordering example: **OPM3X80L75**



OP92BUE23

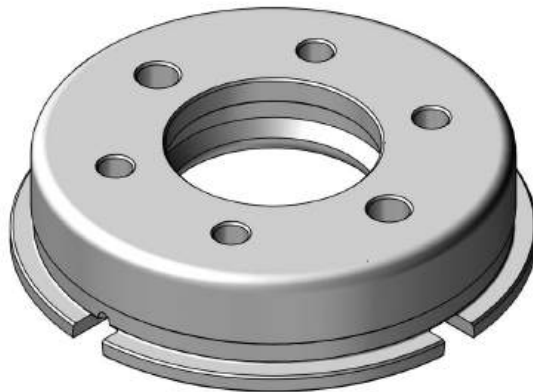

OP92BUE23ID

	kg
OP92BUE23	~0,75
OP92BUE23ID	~0,78

Bestellbeispiel / Ordering example: **OP92BUE23**

**Einbauanleitung / Assembling instructions**

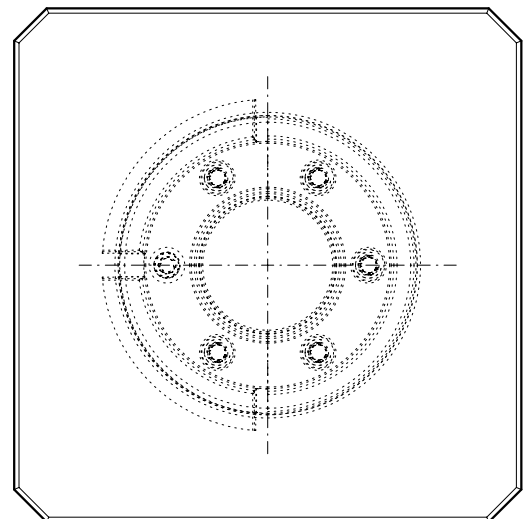
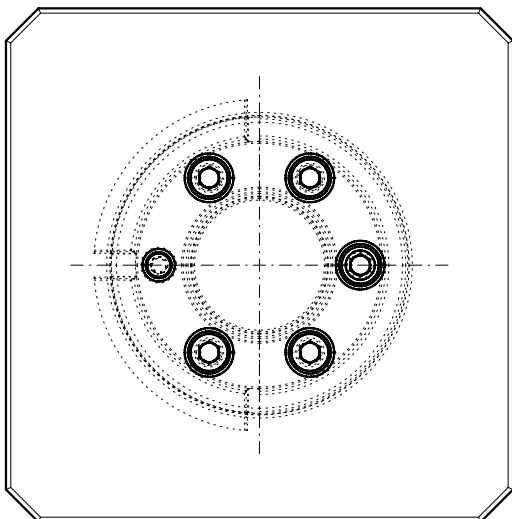
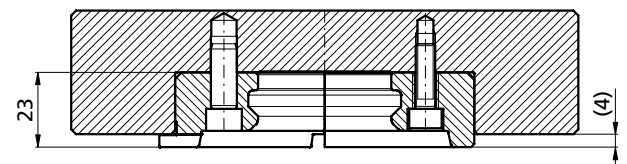
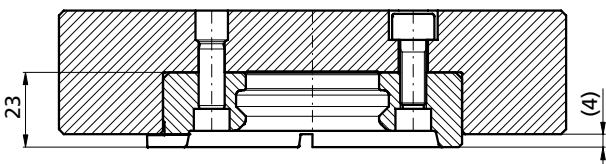
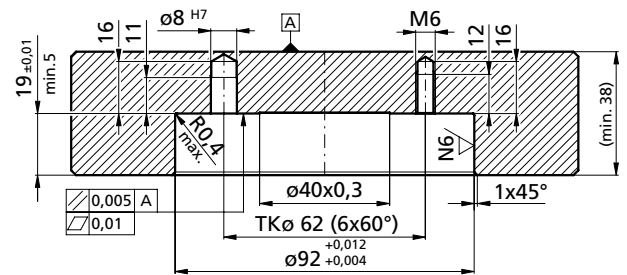
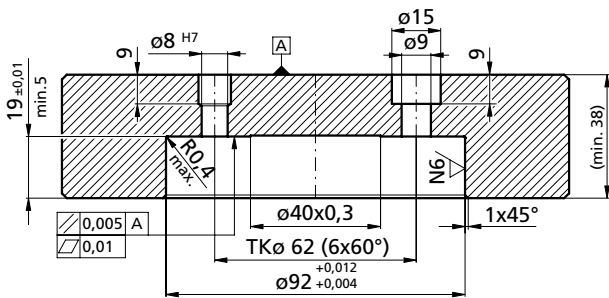

**Zentriereinheit**  
**Chuck unit**

**Zentrierkörper**  
**Chuck body**

**oppSystem**

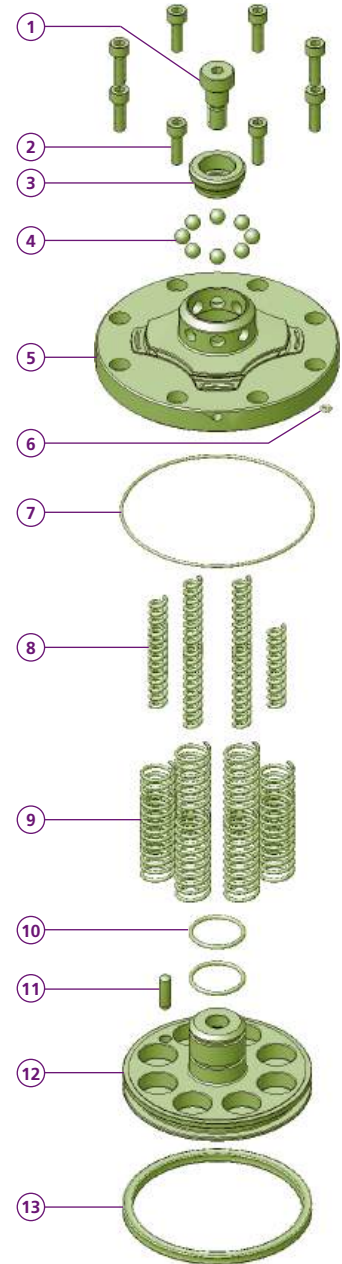
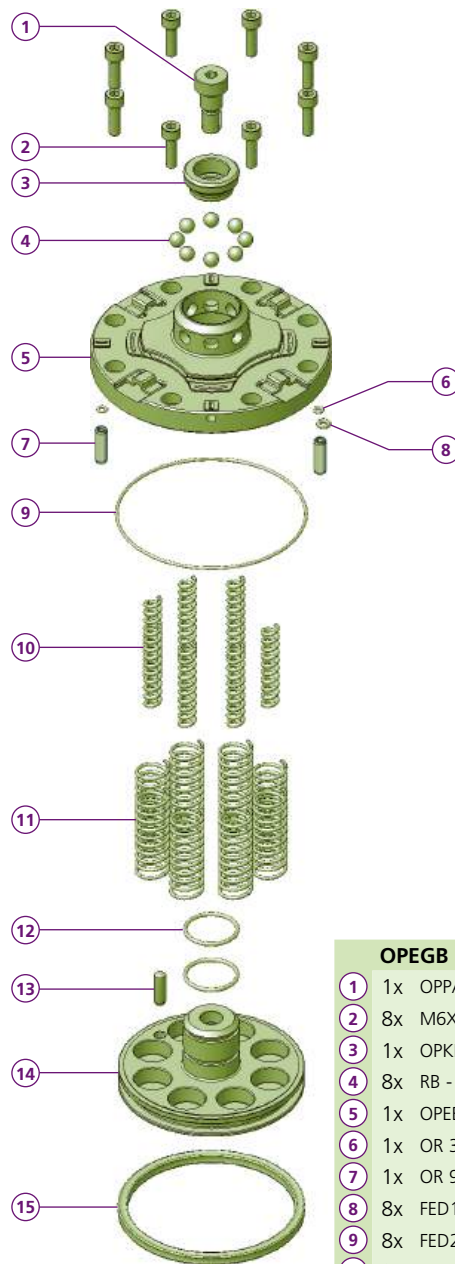

**OPEGBID (Index)**

- ① 1x OPPAS M10x12
- ② 8x M6X20 ST
- ③ 1x OPKN 30x13,5
- ④ 8x RB - 8/G20W
- ⑤ 1x OPEBID
- ⑥ 1x OR 3x1,5
- ⑦ 2x **CCBO0801**
- ⑧ 1x OR 5x1,5
- ⑨ 1x OR 90x1,5
- ⑩ 8x FED1044
- ⑪ 8x FED2051
- ⑫ 2x OR 26x2
- ⑬ 1x 6m6x20 DIN 6325
- ⑭ 1x OPKLB100
- ⑮ 1x OPDR885

kg ~2,28

**OPEGB**

- ① 1x OPPAS M10x12
- ② 8x M6X20 ST
- ③ 1x OPKN 30x13,5
- ④ 8x RB - 8/G20W
- ⑤ 1x OPEB
- ⑥ 1x OR 3x1,5
- ⑦ 1x OR 90x1,5
- ⑧ 8x FED1044
- ⑨ 8x FED2051
- ⑩ 2x OR 26x2
- ⑪ 1x 6m6x20 DIN 6325
- ⑫ 1x OPKLB100
- ⑬ 1x OPDR885

kg ~2,26

**Bestellbeispiel**  
**Ordering example: OPEGBID**

# 1er Palettenträger

## Receiver chuck with 1 chucks

oppSystem

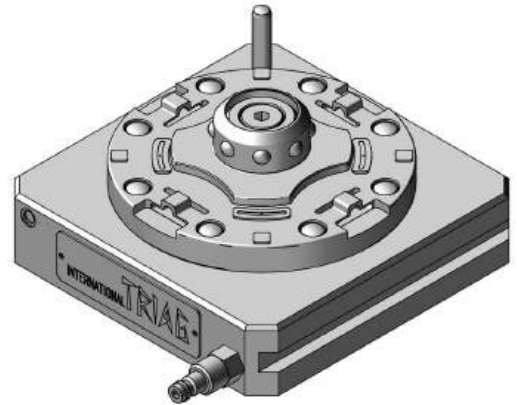
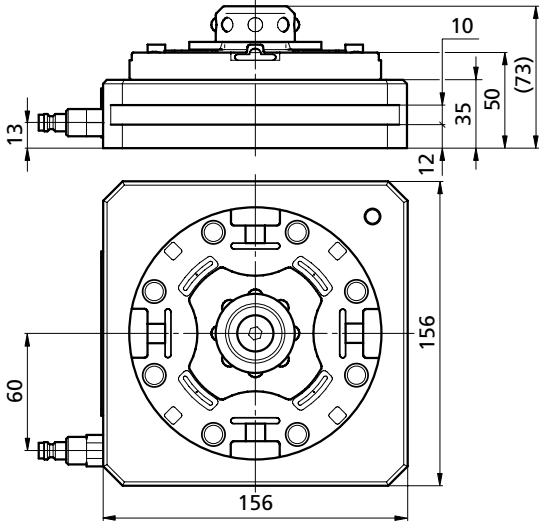

Bestellbeispiel / Ordering example : OPB1ID

	kg
OPB1ID (Index)	~7,6

### 1er Palette

#### Pallet with 1 clamping case

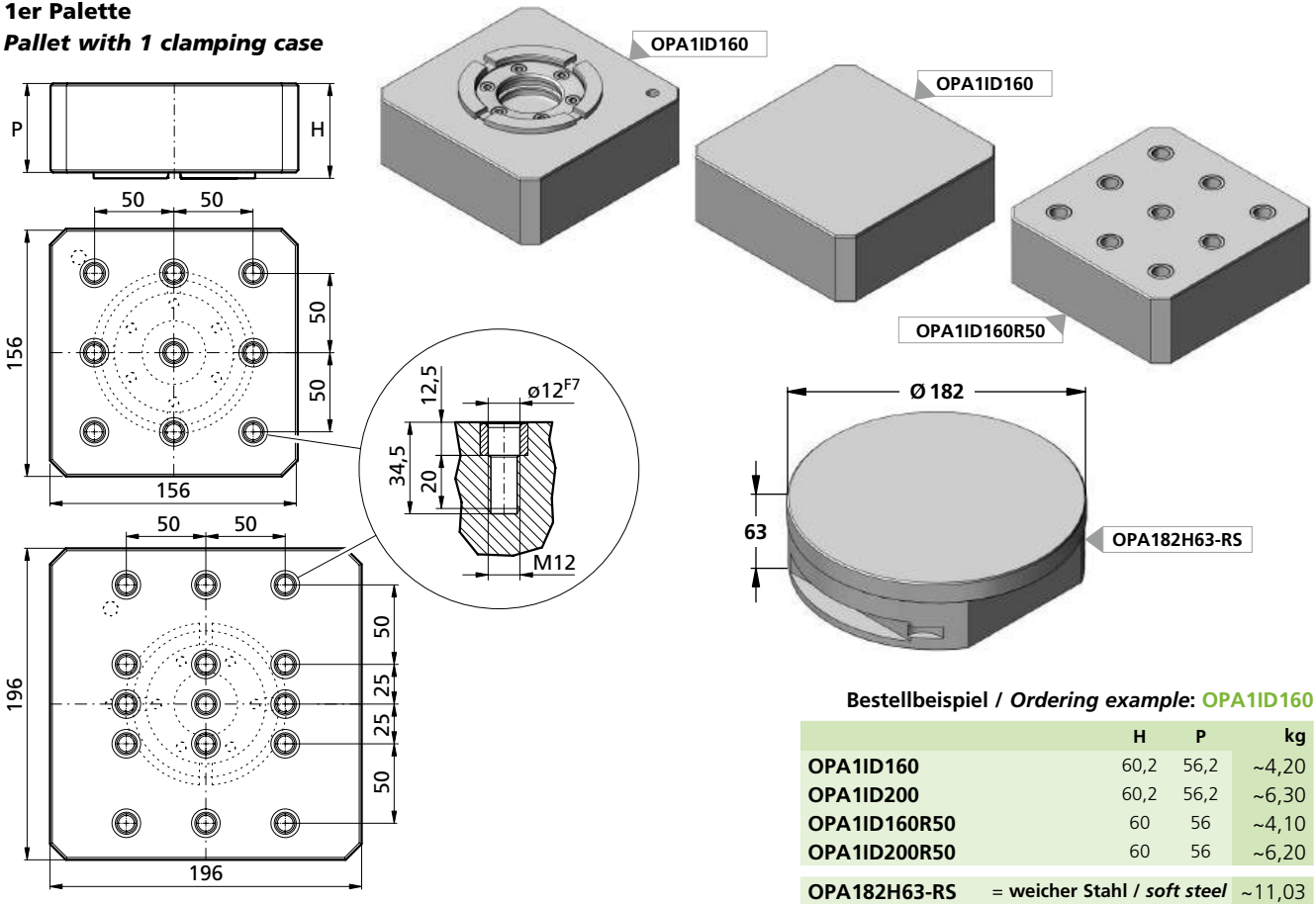

Bestellbeispiel / Ordering example: OPA1ID160

	H	P	kg
OPA1ID160	60,2	56,2	~4,20
OPA1ID200	60,2	56,2	~6,30
OPA1ID160R50	60	56	~4,10
OPA1ID200R50	60	56	~6,20
OPA182H63-RS	= weicher Stahl / soft steel		~11,03

### Basis mit integrierter 0-Punkt Index Aufnahme oppSystem

#### Base rail with integrated oppSystem index

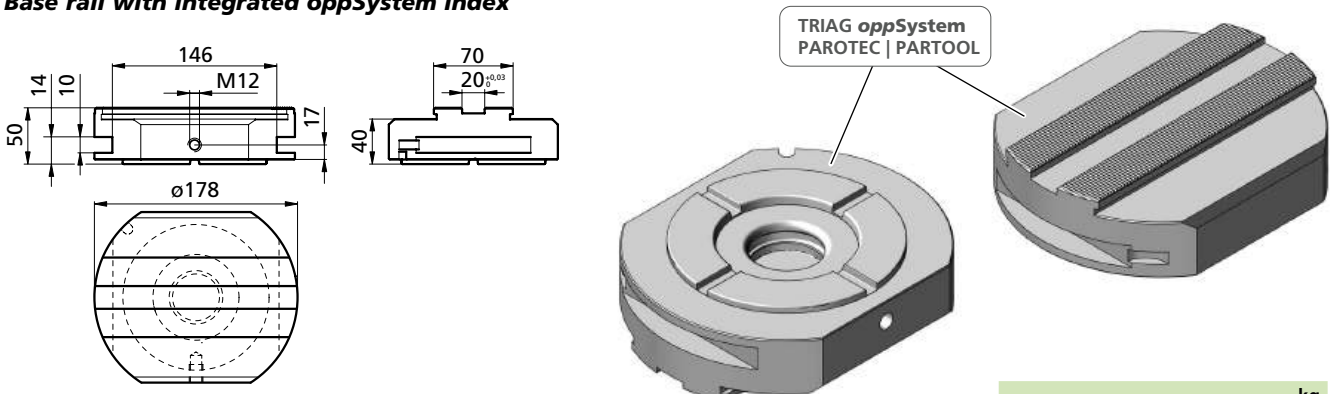

Bestellbeispiel / Ordering example: OPA1IDPCB178

	kg
OPA1IDPCBD178	~8,0

# 2er Palettenträger

## Receiver chuck with 2 chucks

oppSystem

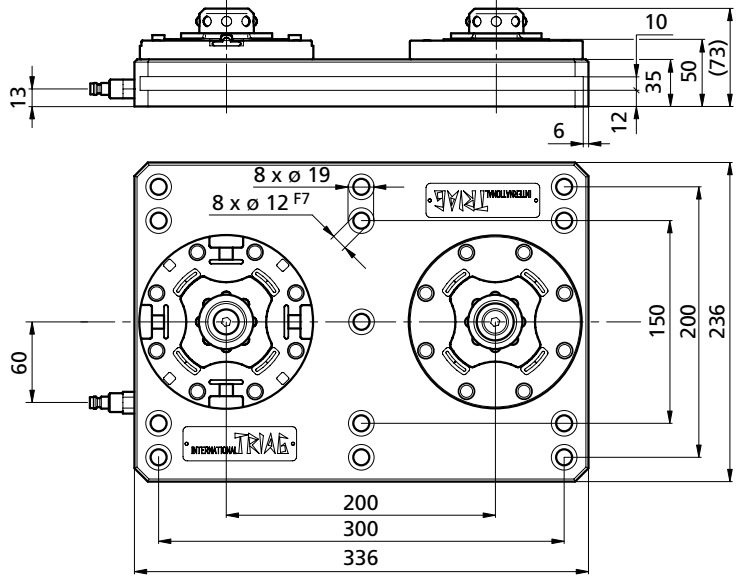
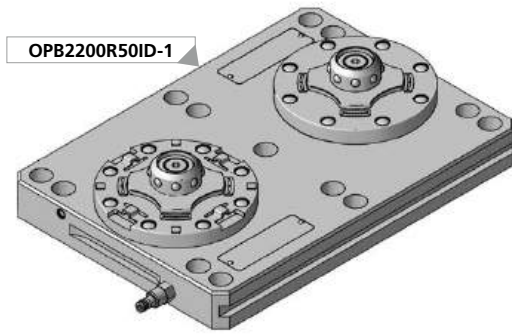

	kg
OPB2200R50	~27,60
OPB2200R50ID-1 (Index)	~30,00
OPB2200R50ID-2 (Index)	~30,00

Bestellbeispiel / Ordering example: **OPB2200R50**

### 2er Palette

#### Pallet with 2 clamping case

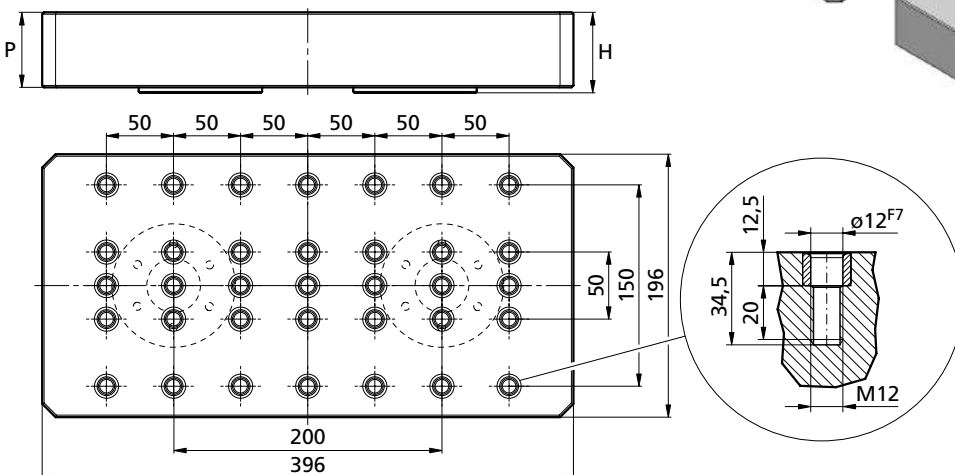
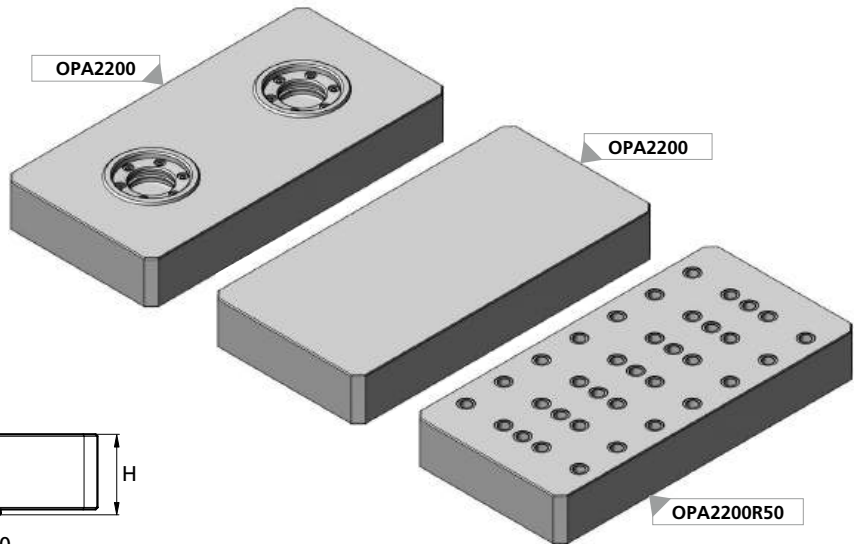

	H	P	kg
OPA2200	60,2	56,2	~12,18
OPA2200R50	60	56	~12,50

Bestellbeispiel / Ordering example: **OPA2200R50**

# 3er Palettenträger

## Receiver chuck with 3 chucks

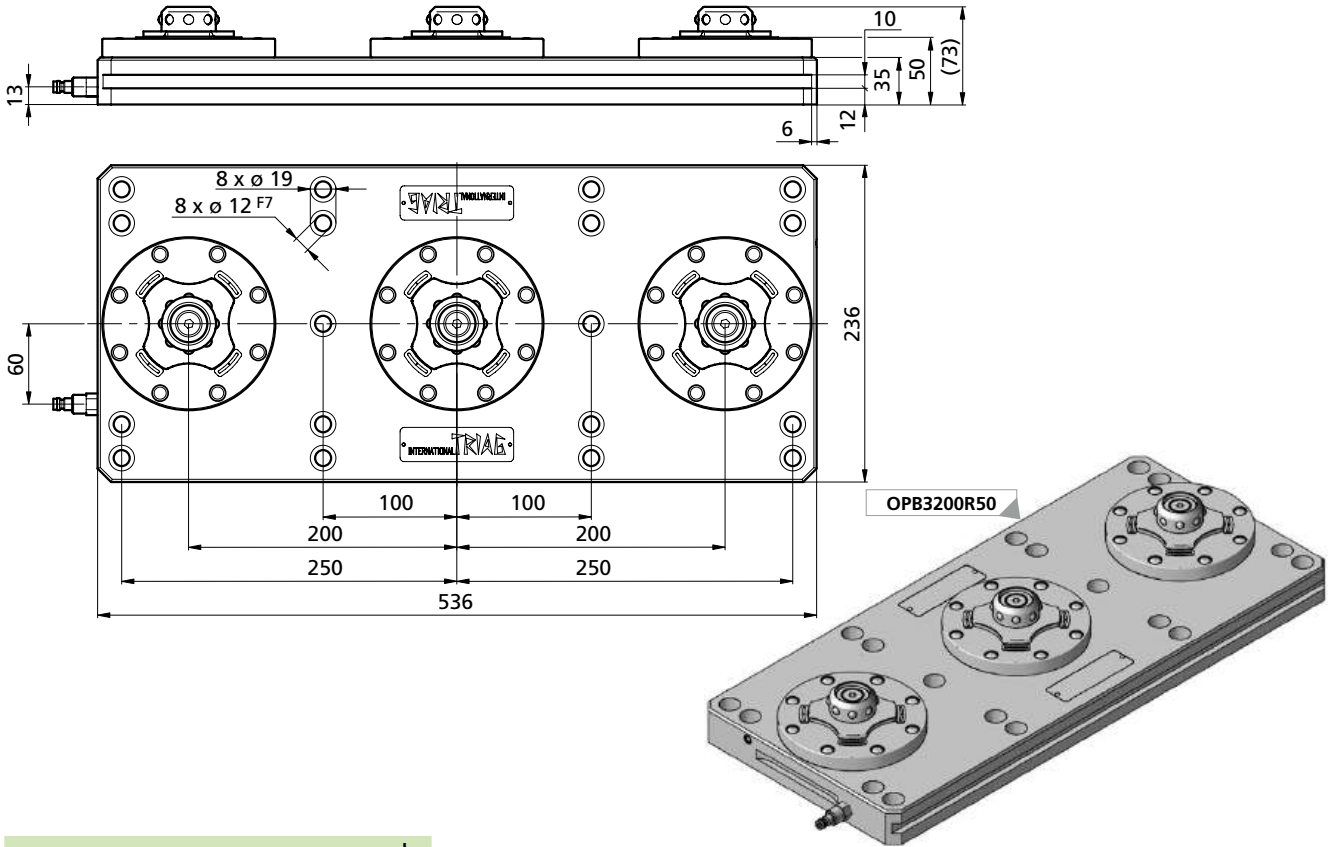

	kg
OPB3200R50	~36,10
OPB3200ID-1 (Index)	~36,00

Bestellbeispiel / Ordering example: **OPB3200R50**

### 3er Palette

#### Pallet with 3 clamping case

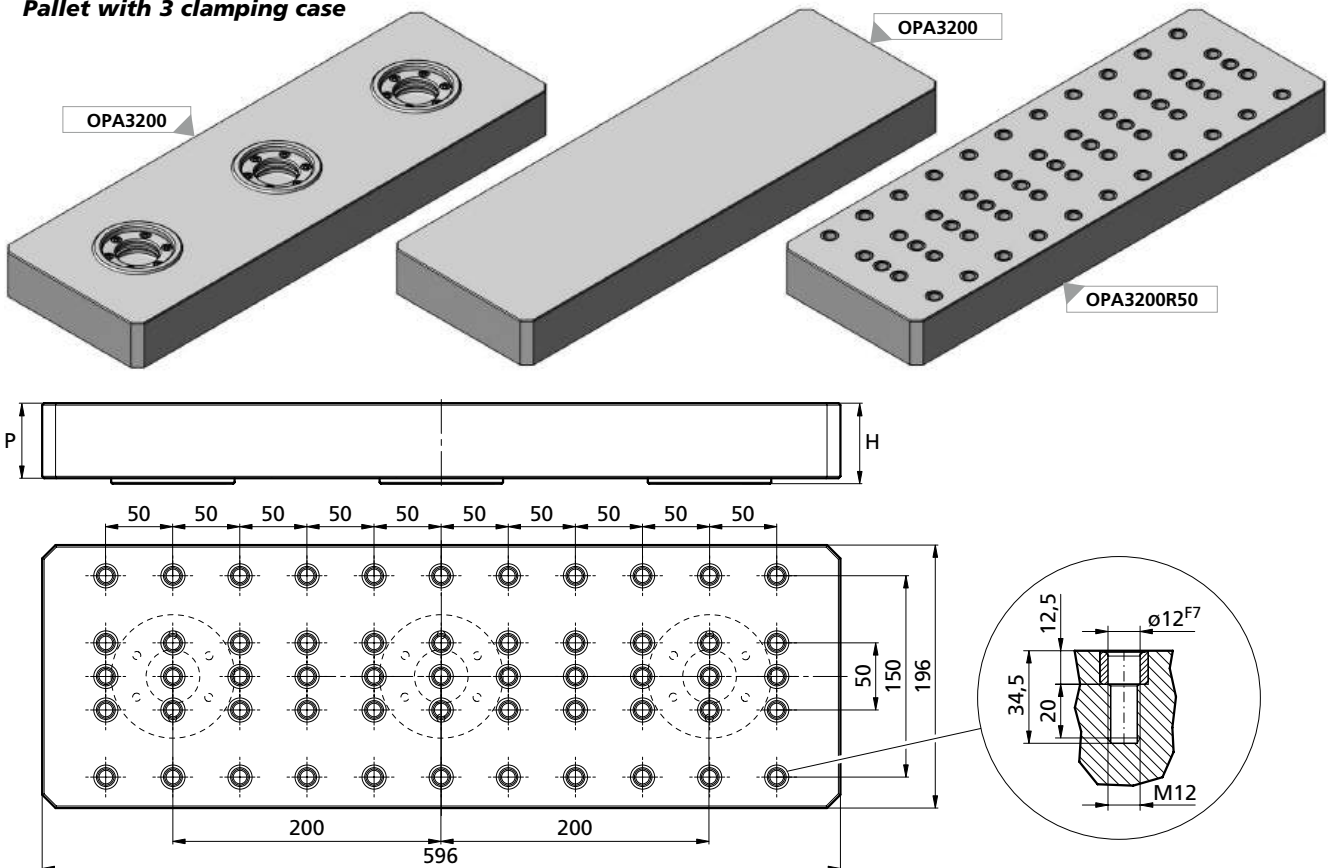

	H	P	kg
OPA3200	60,2	56,2	~18,90
OPA3200R50	60	56	~18,80

Bestellbeispiel / Ordering example: **OPA3200**

# 4er Palettenträger

## Receiver chuck with 4 chucks

oppSystem

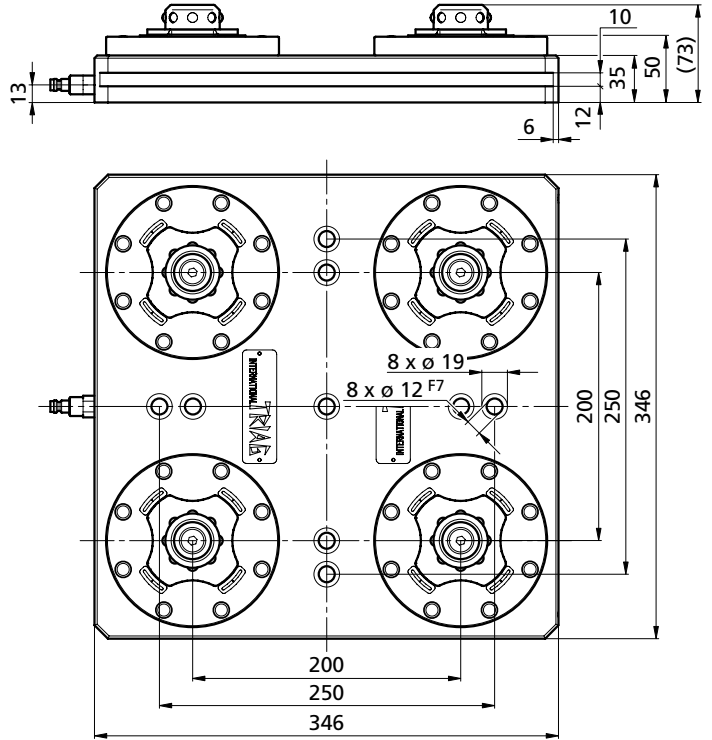
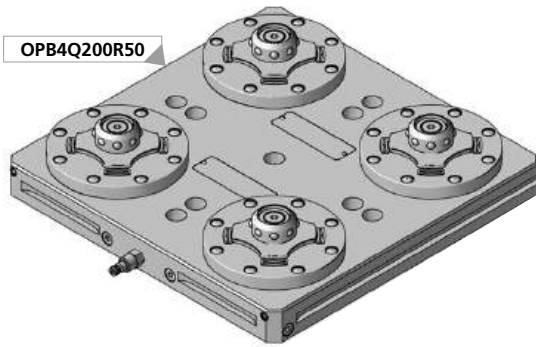

	kg
OPB4Q200R50	~35,80
OPB4Q200R50ID-4	~35,70

Bestellbeispiel / Ordering example: **OPB4Q200R50**

### 4er Palette

#### Pallet with 4 clamping case

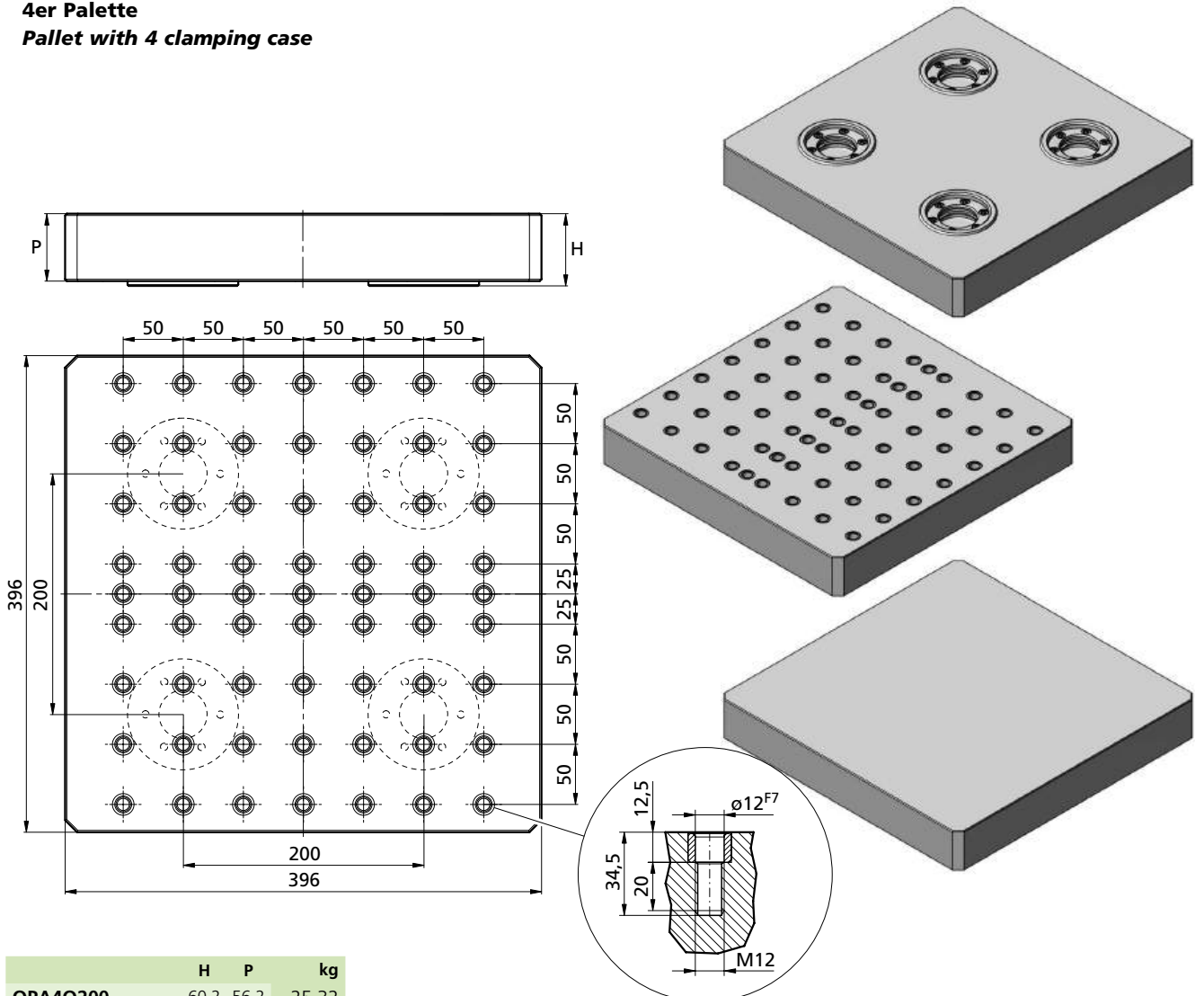

	H	P	kg
OPA4Q200	60,2	56,2	~25,32
OPA4Q200R50	60	56	~25,23

Bestellbeispiel / Ordering example: **OPA4Q200**

**EROWA MTS Einbauspannfutter / Integral chucks**

Einbauvariante (gültig für MTS IntegralChuck Single und Multi). Toleranzen entsprechend der Einbauanleitung beachten!

*Integration variant (applicable to MTS IntegralChucks Single and Multi). Observe tolerances according to integration instructions!*

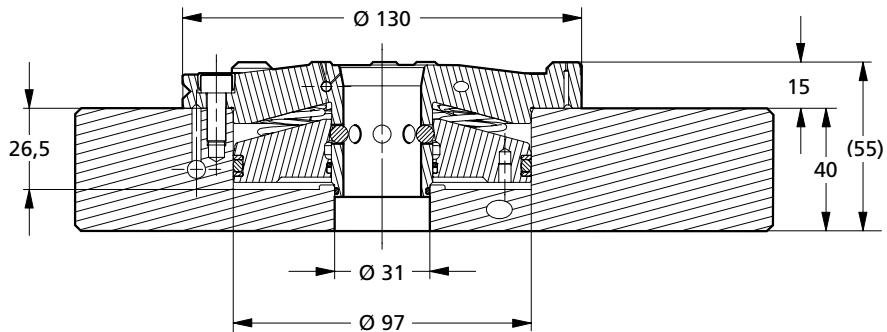

**Manuelle Bedienung**  
*Manual operation*



**Geeignet zur Anwendung unter Flüssigkeit**  
*Suited for submerged operation*



**Geeignet für automatische Anwendung**  
*Suited for automatic operation*



**Mit Druckluftpistole bedienen**  
*Operate with compressed air jet*



**Für spanabhebende Bearbeitung**  
*For chip-removing processes*



**Zum Senkerodieren**  
*For EDM sinking*

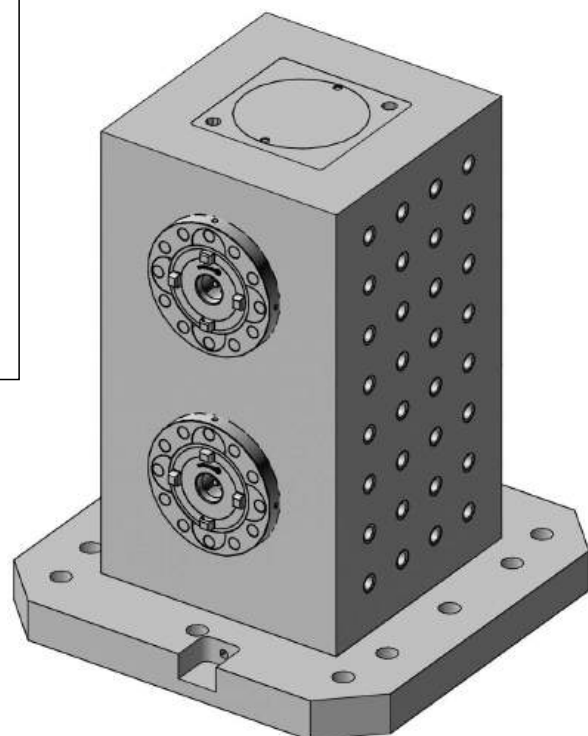

**1 Präzise**

Spielfreie Kurzkegel-Zentrierung.  
 Repetiergenauigkeit: < 0,005 mm.  
 Leichtes Einfahren der Paletten.

**2 Spannmechanismus**

Zuverlässiger Spannmechanismus durch selbsthemmenden Kugelverschluss.

**3 Öffnen**

MTS Spannfutter werden pneumatisch betätigt.

**4 Sauberkeit**

Flüssigkeit kann ablaufen, keine Schmutzecken.

**1 Precise**

Play-free round-cone centering.  
 Repeatability: <0.005 mm.  
 Easy insertion of the pallets.

**2 Clamping mechanism**

Reliable clamping mechanism through self-locking ball lock.

**3 Open**

MTS are operated pneumatically.

**4 Cleanliness**

Liquids can drain off. No dirt traps.

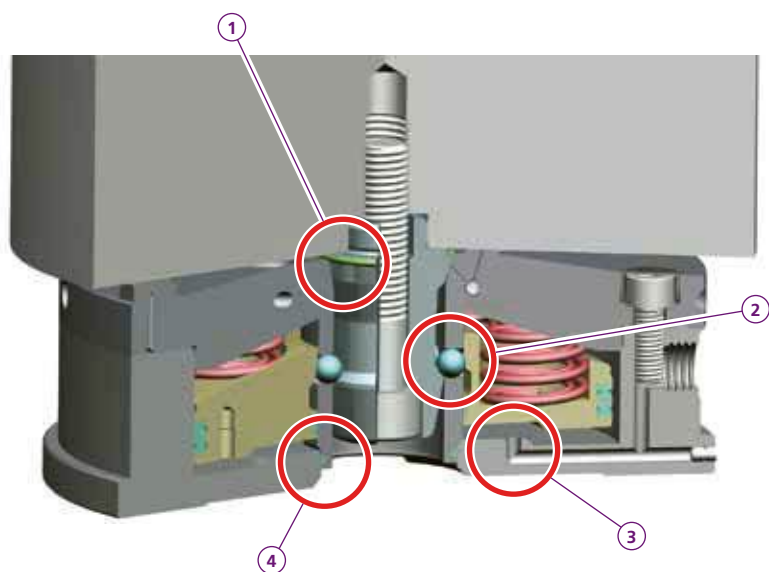

**L x B x H:** Maschinenabhängig  
**L x W x H:** Depending on the machine

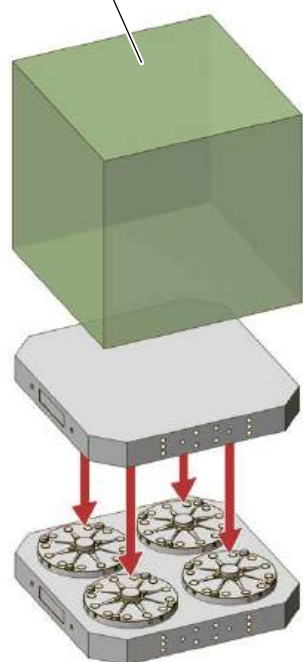

**MTS Spannfutter**

Das pneumatische MTS Spannfutter benötigt trotz der hohen Spannkraft von 12'000 N dank interner Kraftverstärkung nur 7 bar Öffnungsdruck.

**MTS Chuck**

A mere 7 bar of opening pressure results in 12,000 N clamping power thanks to internal power boosting.

**MTS Spannfutter, automatisierbar**

Automatische Reinigung der Auflageflächen und des Zentrierzapfens beim Werkstückwechsel.

**MTS chuck, automatable**

Automatic cleaning of contact surfaces and of the centering spigot cone while the workpiece is changed.

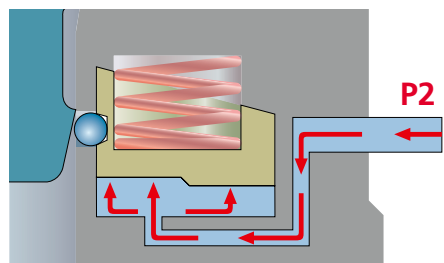

**Anschluss (P2)**  
 Öffnen  
**Prise (P2)**  
 Ouverture

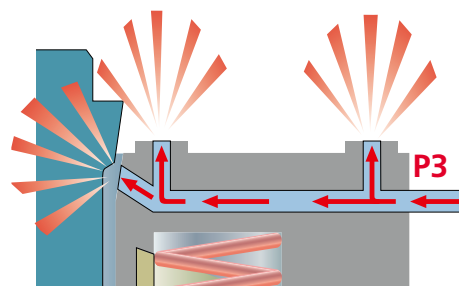

**Anschluss (P3)**  
 Reinigen  
**Prise (P3)**  
 Cleaning

**MTS IntegralChuck S-P (single + multiple / manually)**

ER-033402



- Ausführung** Für den direkten Einbau in Maschinentische, Platten, Spanntürme, Winkel oder Teilapparate.
- Anschlüsse** Zum Öffnen: Pneumatisch.
- Anwendung** Zur Aufnahme von Einzel- oder Mehrfachpaletten.
- Version** For direct integration in machine tables, plates, tombstones, squares or dividing heads.
- Connections** To open: pneumatic or hydraulic.
- Application** To accommodate single or multiple pallets.

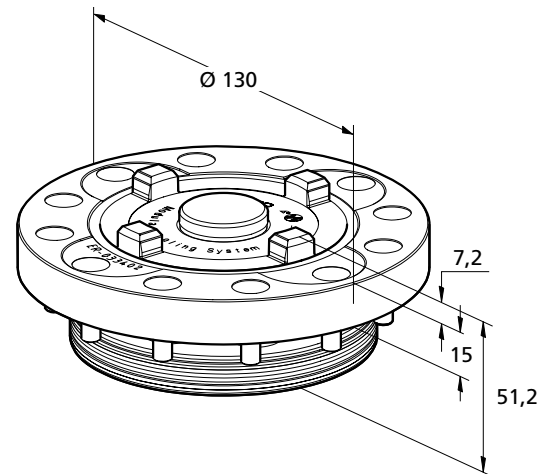

**MTS IntegralChuck S-P/A (single + multiple / auto)**

ER-036802



- Ausführung** Für den direkten Einbau in Maschinentische, Platten, Spanntürme, Winkel oder Teilapparate.
- Anschlüsse** Zum Öffnen: Pneumatisch.  
Zum Reinigen: Pneumatisch.
- Anwendung** Zur Aufnahme von Einzel- oder Mehrfachpaletten.
- Version** For direct integration in machine tables, plates, tombstones, squares or dividing heads.
- Connections** To open: pneumatic.  
To clean: pneumatic.
- Application** To accommodate single or multiple pallets.

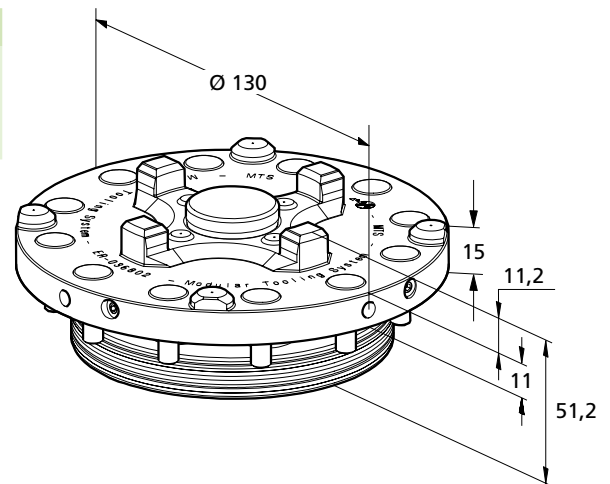

Spannzapfen / Spigot		
ER-033800	manuell / 0-Punkt Zapfen manually zero point locating	
ER-039201	auto / Ausgleichszapfen auto / alignment spigot	
ER-039200	auto / Zapfen mit Spiel auto / spigot with clearance	
ER-038000	auto / 0-Punkt Zapfen auto / Zero point spigot	

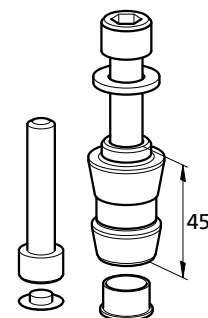

Um Ihnen die schnelle Orientierung über die Anwendungsbereiche der EROWA Produkte zu erleichtern, verwenden wir die folgenden Zeichen:

To make it easier for you to find your way about the fields of application for EROWA products, we use the following symbols:

- S** = Single  
**M** = Multi  
**A** = Automatisierbar / Able to automate  
**P** = Pneumatisch betätigt / Pneumatically operated

- Manuelle Bedienung  
Manual operation
- Geeignet zur Anwendung unter Flüssigkeit  
Suited for submerged operation
- Geeignet für die automatische Anwendung  
Suited for automatic operation
- Für spanabhebende Bearbeitung  
For chip-removing processes
- Zum Senkerodieren  
For EDM sinking

**MTS IntegralChuck M-P (multiple / manually)**

ER-033400



**Ausführung** Für den direkten Einbau in Maschinentische, Platten, Spanntürme, Winkel oder Teilapparate.

**Anschlüsse** Zum Öffnen: Pneumatisch.

**Anwendung** Zur Aufnahme von Einzel- oder Mehrfachpaletten.

**Version** For direct integration in machine tables, plates, tombstones, squares or dividing heads.

**Connections** To open: pneumatic or hydraulic.

**Application** To accommodate single or multiple pallets.

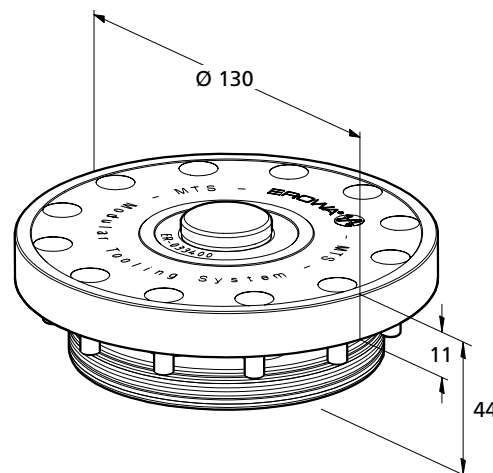

**MTS IntegralChuck M-P/A (multiple / auto)**

ER-036800



**Ausführung** Für den direkten Einbau in Maschinentische, Platten, Spanntürme, Winkel oder Teilapparate.

**Anschlüsse** Zum Öffnen: Pneumatisch.

Zum Reinigen: Pneumatisch.

**Anwendung** Zur Aufnahme von Einzel- oder Mehrfachpaletten.

**Version** For direct integration in machine tables, plates, tombstones, squares or dividing heads.

**Connections** To open: pneumatic.

To clean: pneumatic.

**Application** To accommodate single or multiple pallets.

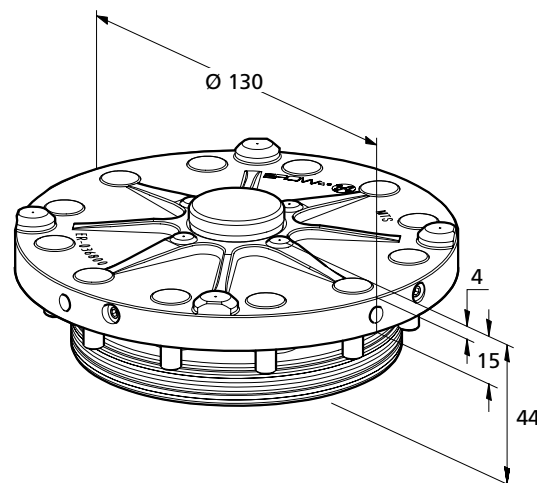

Spannzapfen / Spigot		
ER-033800	manuell / 0-Punkt Zapfen manually zero point locating	
ER-039201	auto / Ausgleichszapfen auto / alignment spigot	
ER-039200	auto / Zapfen mit Spiel auto / spigot with clearance	
ER-038000	auto / 0-Punkt Zapfen auto / Zero point spigot	

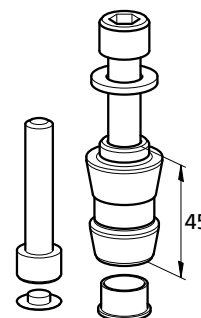

Um Ihnen die schnelle Orientierung über die Anwendungsbereiche der EROWA Produkte zu erleichtern, verwenden wir die folgenden Zeichen:

To make it easier for you to find your way about the fields of application for EROWA products, we use the following symbols:

- S** = Single
- M** = Multi
- A** = Automatisierbar / Able to automate
- P** = Pneumatisch betätigt / Pneumatically operated

- Manuelle Bedienung  
Manual operation
- Geeignet zur Anwendung unter Flüssigkeit  
Suited for submerged operation
- Geeignet für die automatische Anwendung  
Suited for automatic operation
- Für spanabhebende Bearbeitung  
For chip-removing processes
- Zum Senkerodieren  
For EDM sinking

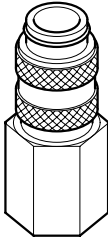
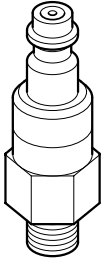
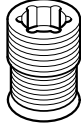
<b>OPSKU</b>	G1/4" Innengewinde <i>Internal thread</i>	<b>OPST-NI</b>	G1/8" Aussengewinde <i>Male thread</i>	<b>OPRV</b>	G1/8" Aussengewinde <i>Male thread</i>
 <p>Schnellkupplung <i>Quick fitting coupling</i></p>		 <p>Stecknippel verschmutzungsgeschützt <i>Plug nipple protected against staining</i></p>		 <p>Rückschlagventil <i>Nonreturn valve</i></p>	
<b>OPANS-8</b> G1/4" Aussengewinde <i>Male thread</i>					

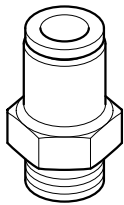

Für 8 mm Schlauch / *For hose*

**Abdeckung**  
**Cover**

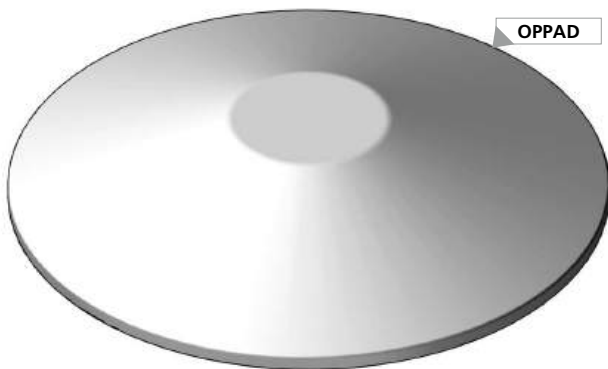

**Dichtlippe**  
**Leakproof cover**

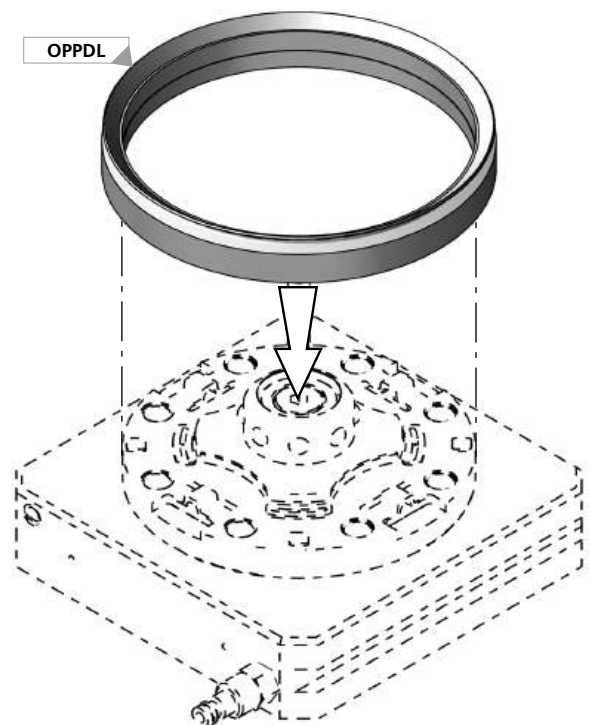

	<b>kg</b>
<b>OPPDL</b>	~0,525
<b>OPPDL</b>	~0,075



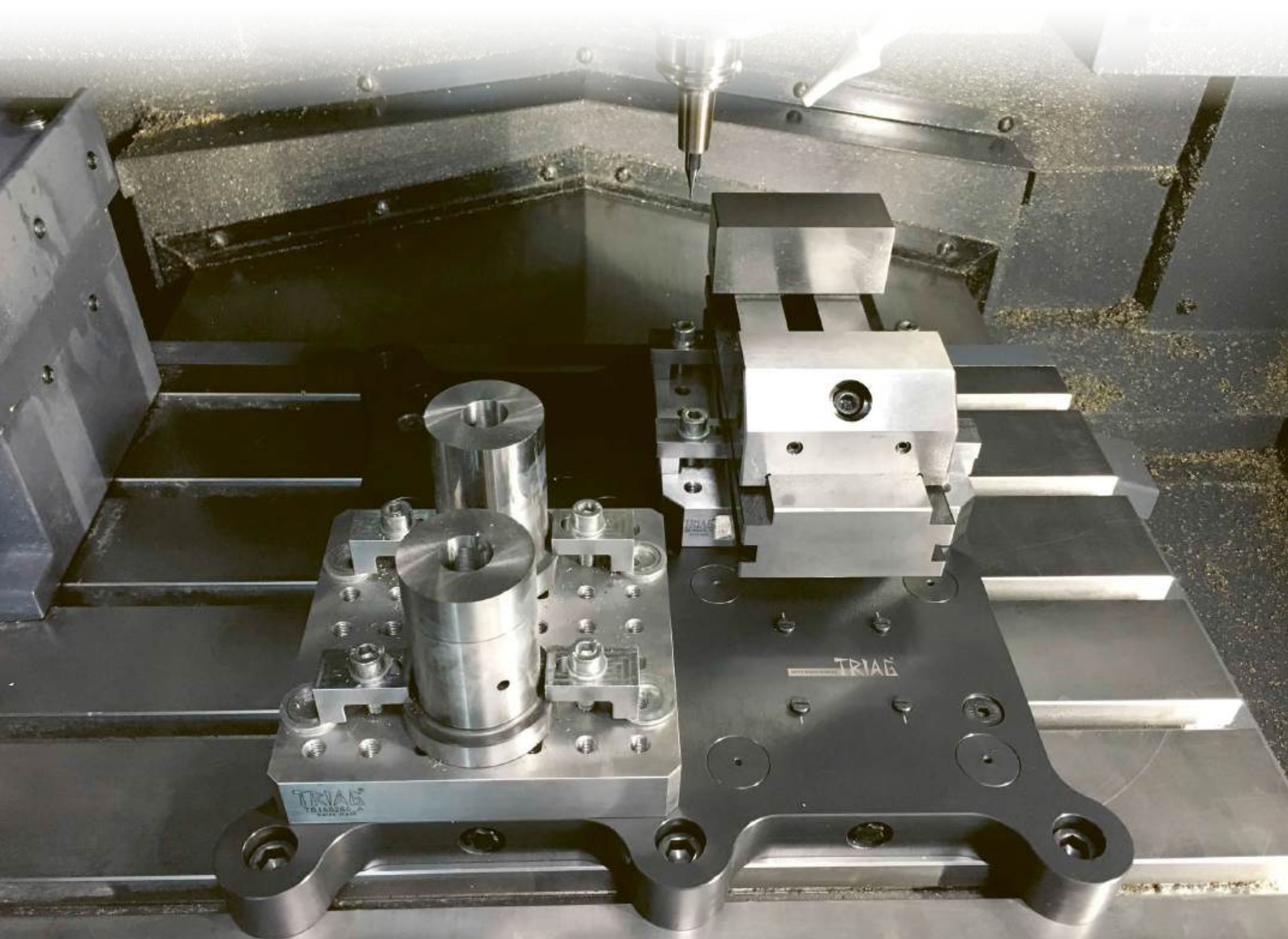



Bestellbeispiel / *Ordering example* : 1x **OPPDL**

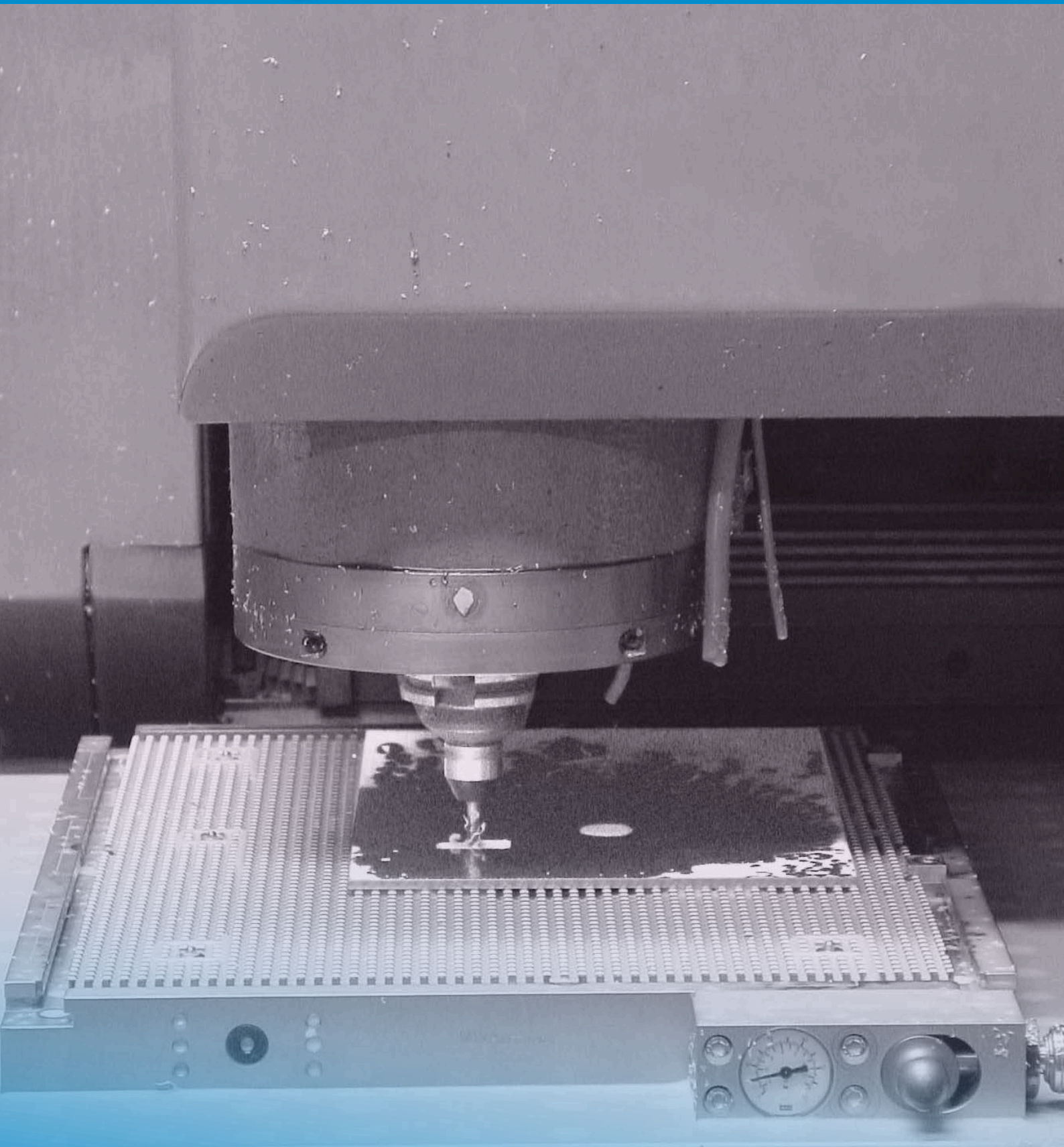

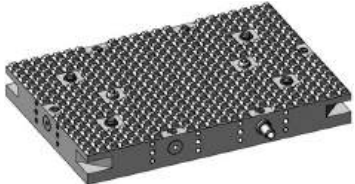

**triva**CLAMP

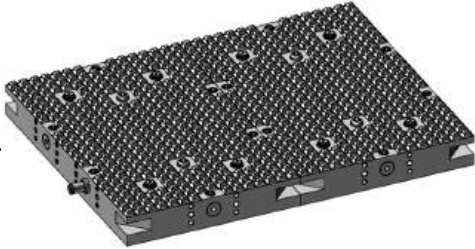
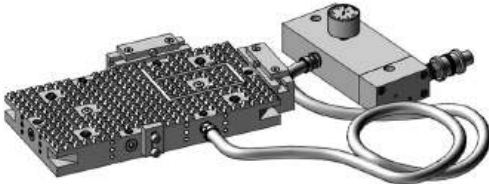

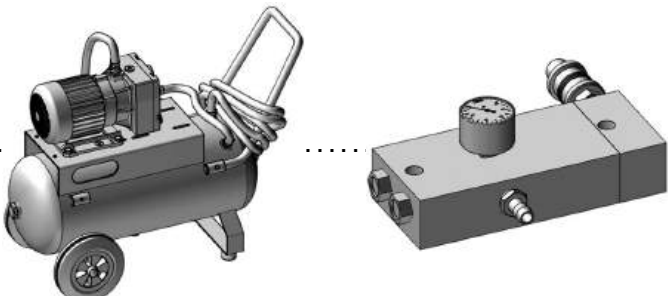
	Einleitung   <i>Introduction</i> .....	305 - 307
	Bedienungsanleitung   <i>Operating manual</i> .....	308 - 309
	Anwendungsbeispiele   <i>Examples of application</i> .....	310 - 312
	Modulare Vakuumplatten   <i>Modular vacuum plates</i> .....	314 - 317
		
	Vakuum-Modul für powerCLAMP   <i>Vacuum module for powerCLAMP</i> .....	318 - 319
		
	Kombinationsvarianten (Vakuumplatten) <i>Possible combination of vacuum plates</i> .....	320
		
	Startersets nach Ihrer Wahl   <i>Starter kit (Your choice)</i> .....	321
		
	Zubehör   <i>Accessories</i> .....	322 - 324
		
	Vakuum erzeugen   <i>Generate vacuum</i> .....	325 - 327
		

### Vakuumspannen

Die mechanische Spannung hat bekanntlich auch Nachteile. Hohe Kräfte auf das Werkstück können zu Druckmarken und Verformungen führen. Vor allem bei grösseren Werkstücken besteht zudem die Gefahr, dass das Werkstück vibriert.

### Workholding by vacuum

*Mechanical clamping, as described before, has disadvantages. High specific forces on the workpiece can cause pressure marks and distortions. And, particularly on large parts, there is a risk that the workpiece will vibrate.*



Bei der Spannung mit Vakuum wird der Druck nicht mechanisch auf das Werkstück sondern durch die umgebende Atmosphäre ausgeübt. Dadurch werden die Werkstücke schonend und gleichmässig über die ganze Auflagefläche fixiert, so dass kaum Vibrationen entstehen.

Der Beschickungs- und Arbeitsraum bleibt zudem frei von Briden und Spannmittel.

- **Diese Spannmethode ist vor allem für grossflächige, dünnwandige, auch nichtmagnetische Werkstücke geeignet.**

#### Triva Clamp besteht aus folgenden Funktionsteilen:

- **Vakuumpplatten** mit passenden Anschlagleisten für den Einsatz mit seitlich einwirkenden Kräften.
- **Dichtschnur aus Silikongummi**, die immer entlang der Peripherie des Werkstücks eingelegt wird. Die Haltekraft wächst proportional zur Aufspannfläche, die durch die Dichtschnur begrenzt wird.
- **Rotations-Vakuumpumpe** mit Schaltventil und Druckwächter optional.
- **Injektorpumpe** mit Schaltventil.

Die Ansaugbohrungen werden mit Hilfe von **Triva Clamp-Ventilen** versiegelt. Wenn die Ventile geschlossen sind, sind keine Löcher in der Platte vorhanden, so dass kaum Kühlflüssigkeit eindringen kann. Das **Triva Clamp-Ventil** wird bei der Auflage des Werkstückes automatisch aktiviert. Ständiges manuelles Öffnen und Verschliessen der Bohrungen entfällt somit.

*In vacuum clamping the clamping force is not applied to the work piece mechanically, but is provided by the surrounding atmosphere. This means that the work piece is gently and evenly pulled down over the whole supporting surface, so that vibration is minimized. As there are no obstructing brackets, clamps or workholding modules in the working and loading area, there are fewer chances for collisions with the tool.*

- **This clamping method is particularly suitable for large surface, thin-walled and also non magnetic work pieces.**

#### Triva Clamp consists of the following functional devices:

- **Vacuum plates** with suitable stop gauges for application with lateral workholding forces.
- **Silicone-rubber sealing cord** inlaid along the periphery of the work piece. The clamping force increases proportionally to the surface area defined by the sealing cord.
- **Rotary vacuum pump** with control unit and pressure sensor.
- **Injector pump** with control unit.

*The suction holes are sealed by the **Triva Clamp valves**. With these valves closed there are no holes in the plate so that hardly any coolant can enter. The **Triva Clamp valve** is automatically activated by placing the work piece on the vacuum plate. Hence constant opening and closing of the suction holes is omitted.*

### Theoretische Haltekraft:

Unter Einbezug eines Sicherheitsfaktors für atmosphärische Druckschwankungen und Leckagen im Vakuumkreislauf rechnen wir mit einem zur Verfügung stehenden Druck von 0,85 bar Vakuum oder 8,5 N/cm<sup>2</sup> (wobei der Druck von der Höhe über Meer abhängig ist).

Diesen Druck bezeichnen wir als theoretisch 100%. Bei 300 cm<sup>2</sup> Spannfläche ergibt sich also eine theoretische Spann-/Haltekraft von 8,5 N/cm<sup>2</sup> x 300 cm<sup>2</sup> = 2550N.

Diese theoretische Haltekraft basiert auf einem vollständigen Hohlraum unter dem Werkstück. Dies ist in der Praxis jedoch nicht möglich, weil das Werkstück abgestützt werden muss.

### Effektive Haltekraft:

Das heisst, je grösser der Hohlraum unter dem Werkstück und je geringer die Auflagefläche für das Werkstück, desto grösser sind die Haltekräfte.

**Die effektive Haltekraft ist folglich abhängig vom Wirkungsgrad des Vakuumspannsystems.**

### Vakuumspannsysteme im Vergleich:

#### Lochplatte Plate with suction holes

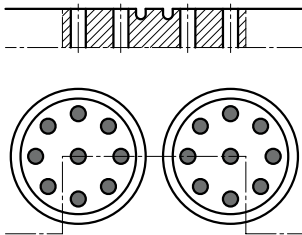

Pro Element Ø 40 mm  
9 Bohrungen Ø 4 mm.  
Each section of Ø 40 mm  
having 9 bores of Ø 4 mm.

Wirkungsgrad: 9%  
Degree of efficiency: 9%

#### Schlitzplatte Plate with slots

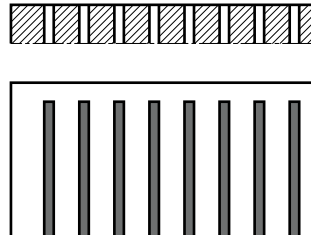

Steg 8 mm, Schlitz 2 mm  
Slots 2 mm, bar 8 mm

Wirkungsgrad: 25%  
Degree of efficiency: 25%

### Theoretical holding force:

Including a safety factor for atmospheric pressure variations and leaks within the vacuum circuit, we calculate an available pressure of 0,85 bar (12,1psi) vacuum equalling 8,5 N/cm<sup>2</sup> (whereas pressure is dependent on altitude).

This amount of pressure is referred to as theoretically attainable 100%. For 300 cm<sup>2</sup> /46,5 sq inch the pressure thus is 8,5 N/cm<sup>2</sup> x 300 cm<sup>2</sup> = 2550N (12,1psi x 46,5sq in = 562lbs).

This theoretically calculated holding force is based upon a hollow space underneath the entire work piece. This is not possible because the work piece must be supported. Therefore we have to subtract the area supporting the workpiece.

### Effective holding force:

In other words: the larger the work piece supporting area, thus reducing the hollow space representing the holding area, the lesser the holding force.

**Consequently, the effective holding force depends entirely upon the rate of efficiency of the vacuum system.**

### Comparison of various vacuum systems:

#### Nutenplatte Plate with U-shaped grooves

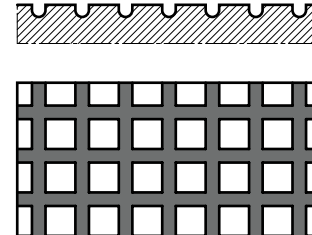

Raster 10x10 mm, Nute 3 mm  
Grid 10x10 mm, grooves 3 mm

Wirkungsgrad: 51%  
Degree of efficiency: 51%

#### Triva Clamp Waffelmuster Triva Clamp waffle pattern

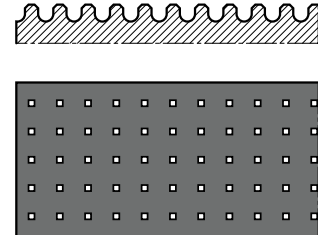

Raster 6,5 mm, Nute 5 mm  
Grid 6,5 mm, grooves 5 mm

Wirkungsgrad: 92%  
Degree of efficiency: 92%

### Besonderheiten von Triva Clamp:

Durch die besondere Formgebung der Werkstückauflage (Waffelmuster) erreicht Triva Clamp einen kaum zu übertreffenden **Wirkungsgrad von theoretisch 92% = 2346 N bei einem maximal erreichbaren Wert von 2550 N (bezogen auf 300 cm<sup>2</sup> Spannfläche).**

### Toleranzen

Höhe 40 mm ± 0,02 / 400 mm  
Ebenheit über alles: ± 0,03 / 400 mm

### Special features Triva Clamp:

The unique shape of the Triva Clamp workpiece supporting area (waffle pattern) guarantees maximum attainable holding force with a rate of **efficiency of theoretically 92%, equalling 2346 N holding force applied to the work piece of 300cm<sup>2</sup> (46,5sq in) holding surface.**

### Tolerances

Height 40 mm ± 0,02 / 400 mm  
Flatness all over: ± 0,03 / 400 mm

Alle Vakuumplatten sind aus hochfestem Aluminium hergestellt und für eine lange Lebensdauer **Hartanodisiert** beschichtet. Durch an jeder Seite angebrachte Koppelbohrungen wird es möglich, die Spannfläche nach Bedarf allseitig zu erweitern.

Vacuum plates are made from high tensile aluminum alloy, are **hard anodized** treated for long tool life. Triva plates can be coupled longitudinally and transversely with any holding plate to suit workpieces, limited by machine table size only.

**Mechanische Spannung = Druck auf das Werkstück,** daraus resultieren:

- Belastung des Werkstücks
- Druckmarken in weichen Werkstoffen
- Verformung labiler Teile
- Risiko von Vibrationen

**Mechanical clamping = pressure applied to workpiece,** result:

- Stress applied to workpiece
- Pressure marks in soft materials
- Deforming of delicate workpieces
- Risk of vibrations

**Vakuumspeisung = Druck auf Spannplatte**

Durch die umgebende Atmosphäre, daraus folgt:

- Schonende, gleichmässige Fixierung jeglicher Werkstoffe über die ganze Auflagefläche
- Keine Vibrationen
- Freier Bestückungs- und freier Arbeitsraum

**Vacuum clamping = pressure upon vacuum-plate**

By the surrounding atmosphere, resulting in:

- Equal distribution of holding force over the Entire workpiece holding surface
- Machining with no risk of vibrations
- Free, clear loading and processing area

### Spannen von Platten mit Klemm-Briden

Haltekräft nur am Rand. Vibrationen in Werkstückmitte. Folgeoperationen notwendig.

#### Clamping of plates, using clamps

Edges fixed only - Vibrations in center of workpiece - Subsequent operations required.

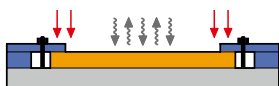

### Spannen von unförmigen Werkstücken

Für Werkstücke mit unförmigen Konturen und Durchgangsbohrungen stellen wir Spezialvorrichtungen her.

#### Holding of bulky workpieces

We build special devices for workpieces with bulky outlines and through bore-holes.

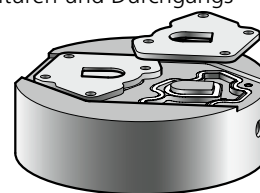

### Spannen von Platten mit Tiefspannbacken

Haltekräft nur am Rand, Vibrationen in Werkstückmitte. Hoher Spanndruck erzeugt Spannung und Verformung.

#### Clamping of plates, using clamping jaws

Also high pressure applied to workpiece, holding effect at the edges - Risk of deformation and vibrations.

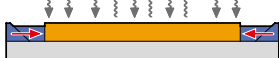

### Spannen von Platten auf Vakuum-Platte

Haltekräft gleichmässig über ganze Auflagefläche verteilt. Keine Vibrationen - Freier Arbeitsraum.

#### Holding of plates, using vacuum-plate

Holding force equally spread all over the workpiece holding area - No vibrations - Free processing area.

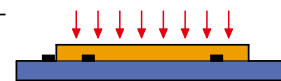

### Kubus spannen im Schraubstock

Belastung des Werkstücks - Risiko von Druckmarken.

#### Clamping of cubic-shaped items, using vise

Stress applied - Risk of pressure marks in workpiece.



### Kubisches Werkstück spannen mit Vakuum-Platte und Steilwänden

Werkstück an 3 (bis 5) Seiten ohne mechanischen Druck gehalten.

#### Holding of cubic-shaped item, using vacuum-plate and vertical walls

Workpiece held from 3 (up to 5) directions. No stress applied - No stress applied - No pressure marks.

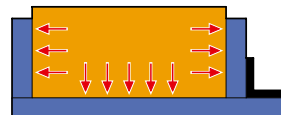

### Spannen von U-Profilen im Schraubstock

Risiko von Deformationen und Vibrationen.

#### Clamping of U-profile, using vise

Risk of deformation and vibrations during processing.

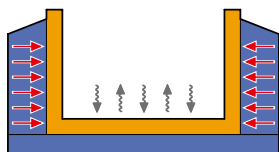

### Spannen von U-Profilen mit Vakuum-Platte und Steilwänden

Allseitig gleichmässige, druckfreie Aufspannung. Bearbeitung ohne Risiko von Vibrationen.

#### Holding of U-profile, using vacuum-plate and 2 vertical walls

Uniform, stressfree holding from 3 directions - No risk of deformations or vibrations during processing.

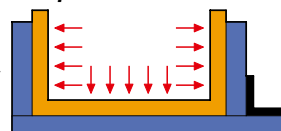

### Spannen von Winkelprofil mit Briden

Umständliches Bestücken und Bearbeiten sowie grosse Vibrationen.

#### Clamping of angled workpiece, using clamps

Bothersome clamps, vibrations, subsequent operation.

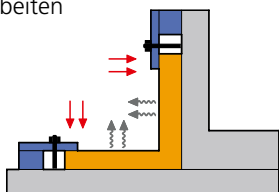

### Spannen von Winkelprofil mit Vakuum-Platte und 1 Steilwand

Gleichmässig verteilte Haltekräft. Leichtes Bestücken und freier Arbeitsraum. Keine Vibrationen, keine Nacharbeit notwendig.

#### Holding of angled workpiece, using vacuum-plate and 1 vertical wall

Uniform stressfree holding - No risk of vibrations - No clamps, free, clear work area for easier, faster loading and processing.

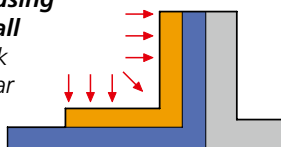

Rote Pfeile → zeigen die Spannrichtung, graue Pfeile ~> zeigen Vibrationskräfte  
Red arrows → show the holding force direction, gray arrows ~> show vibration forces

**Vakuumplatte auf Maschinentisch befestigen / Mounting vacuum plate on machine table**

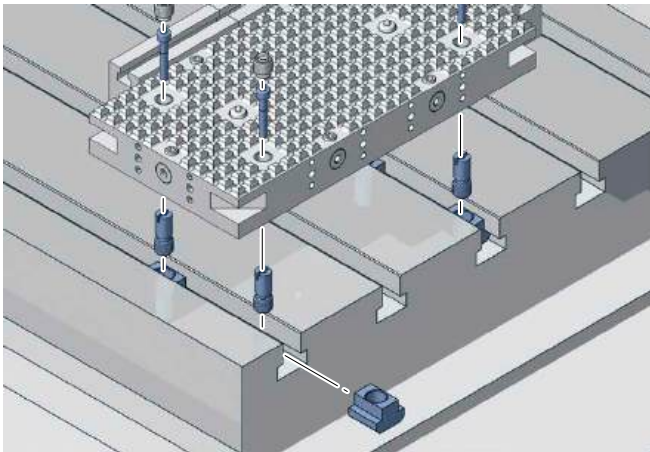

Mechanisch befestigt / Mechanical mounting

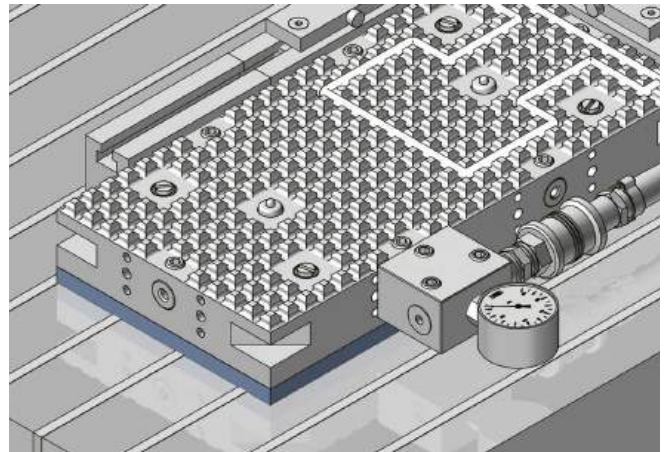

Magnetisch befestigt / Magnetical mounting

**Platten koppeln / Connect plates**

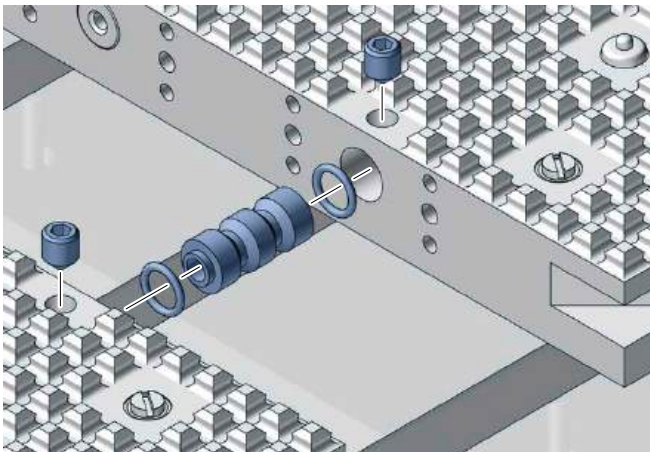

Mit Vakuumverbinder / With vacuum circuit connector

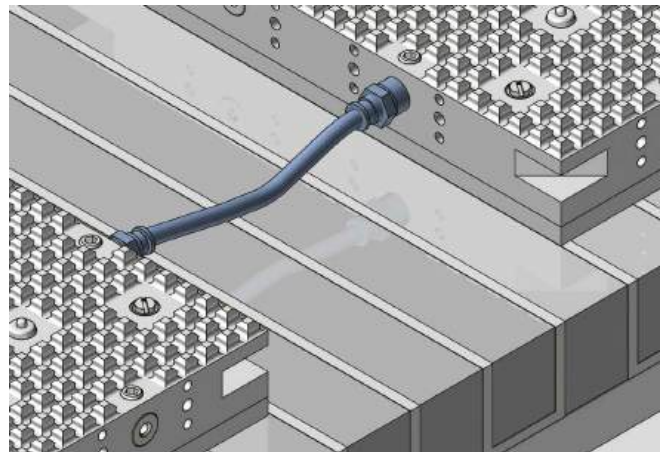

Mit Verbindungsschlauch / With connector-tube

**Mit Pumpe verbinden / Connect to pump**

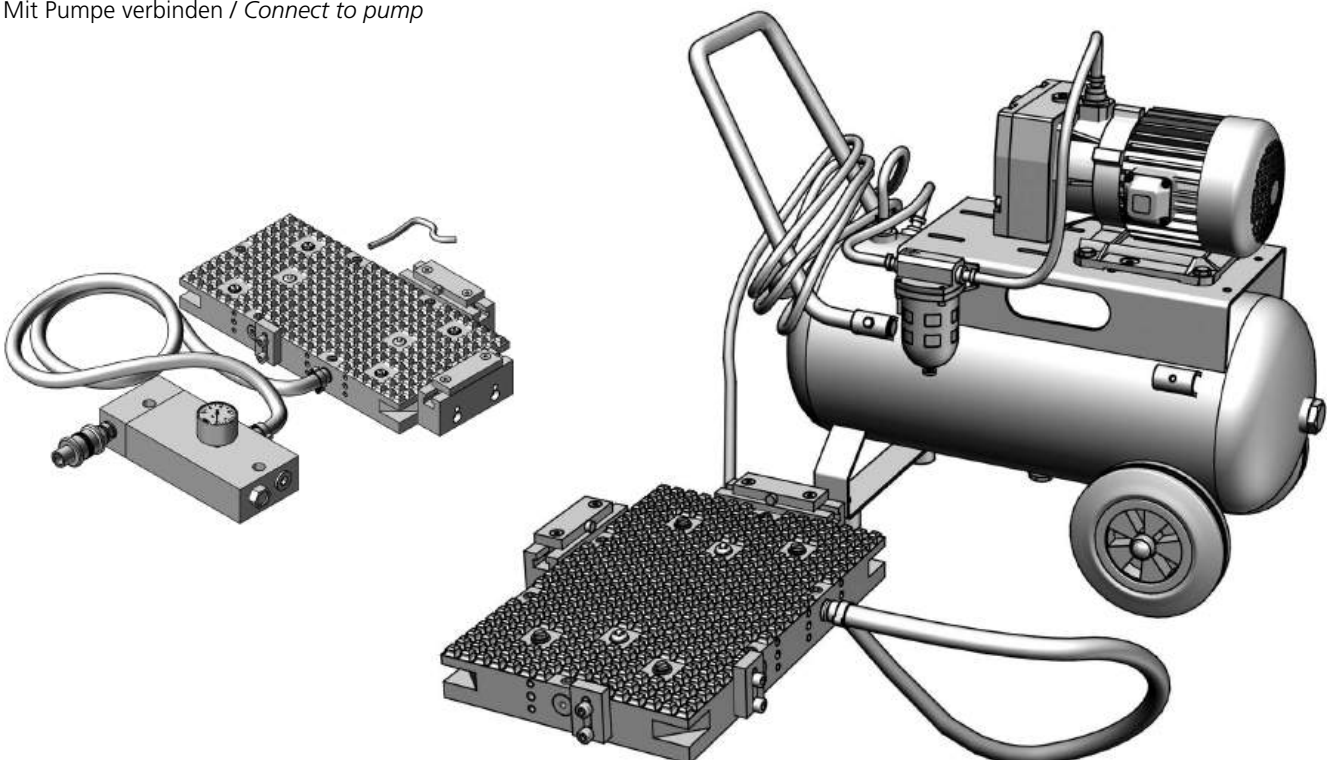

Dichtsnur und Werkstück einlegen / Insert sealing cord and workpiece

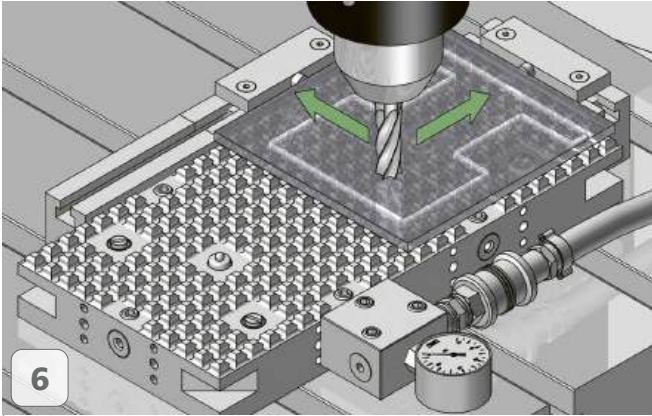
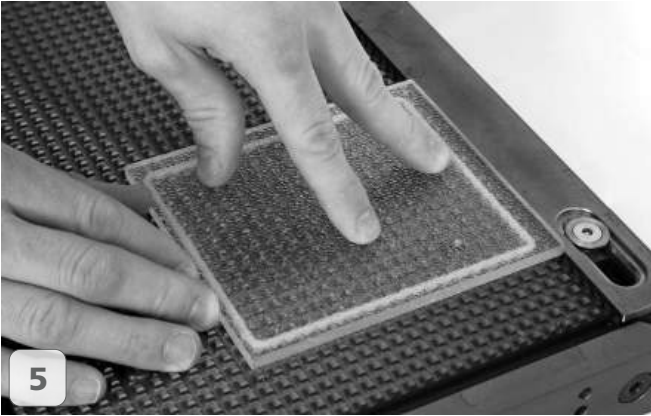
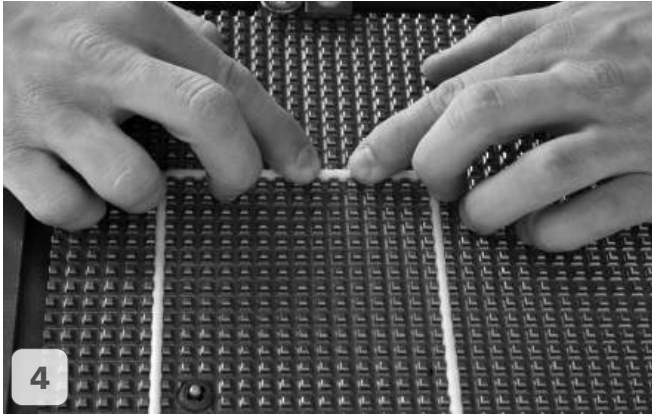
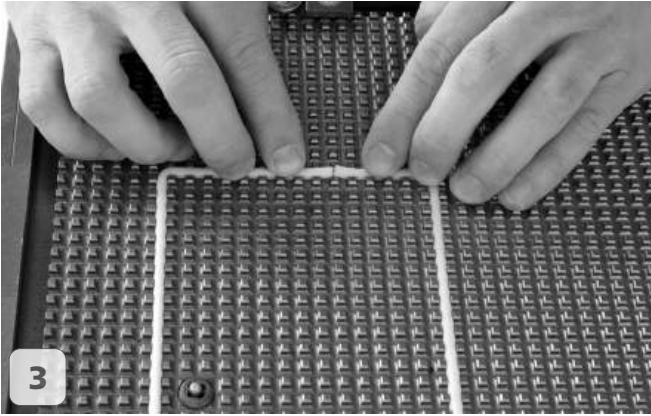
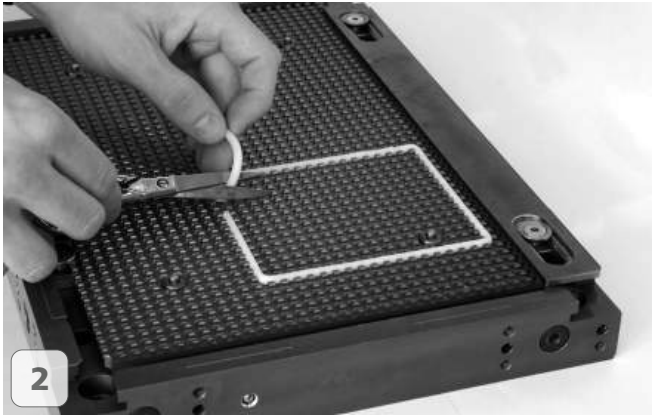
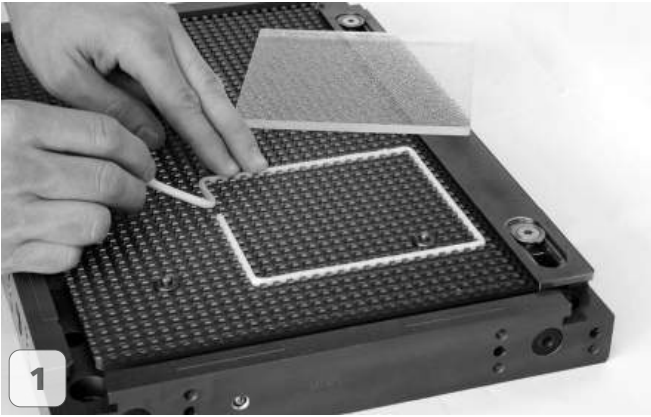

**Fräsrichtung beachten:**  
wenn möglich, gegen Festanschlüge fräsen.  
**Pay attention to machining direction:**  
if possible, toward stop gages milling.

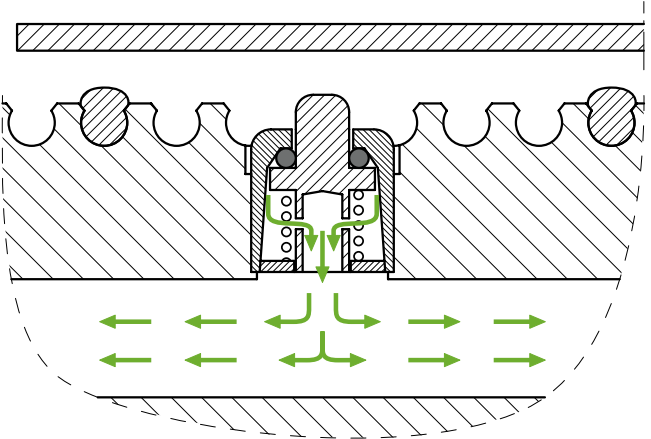

Ventil geschlossen / Valve sealed

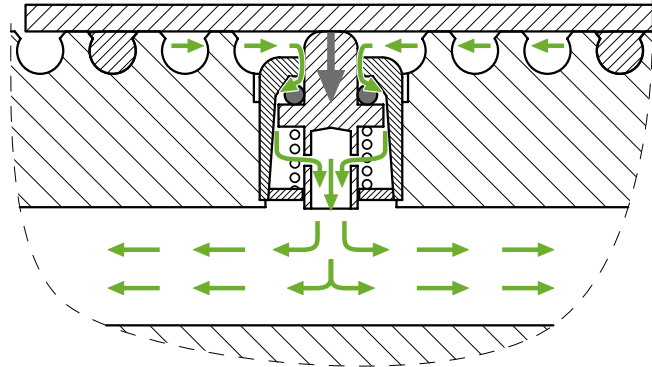

Werkstück eingelegt: Ventil offen  
Workpiece inserted: Valve open



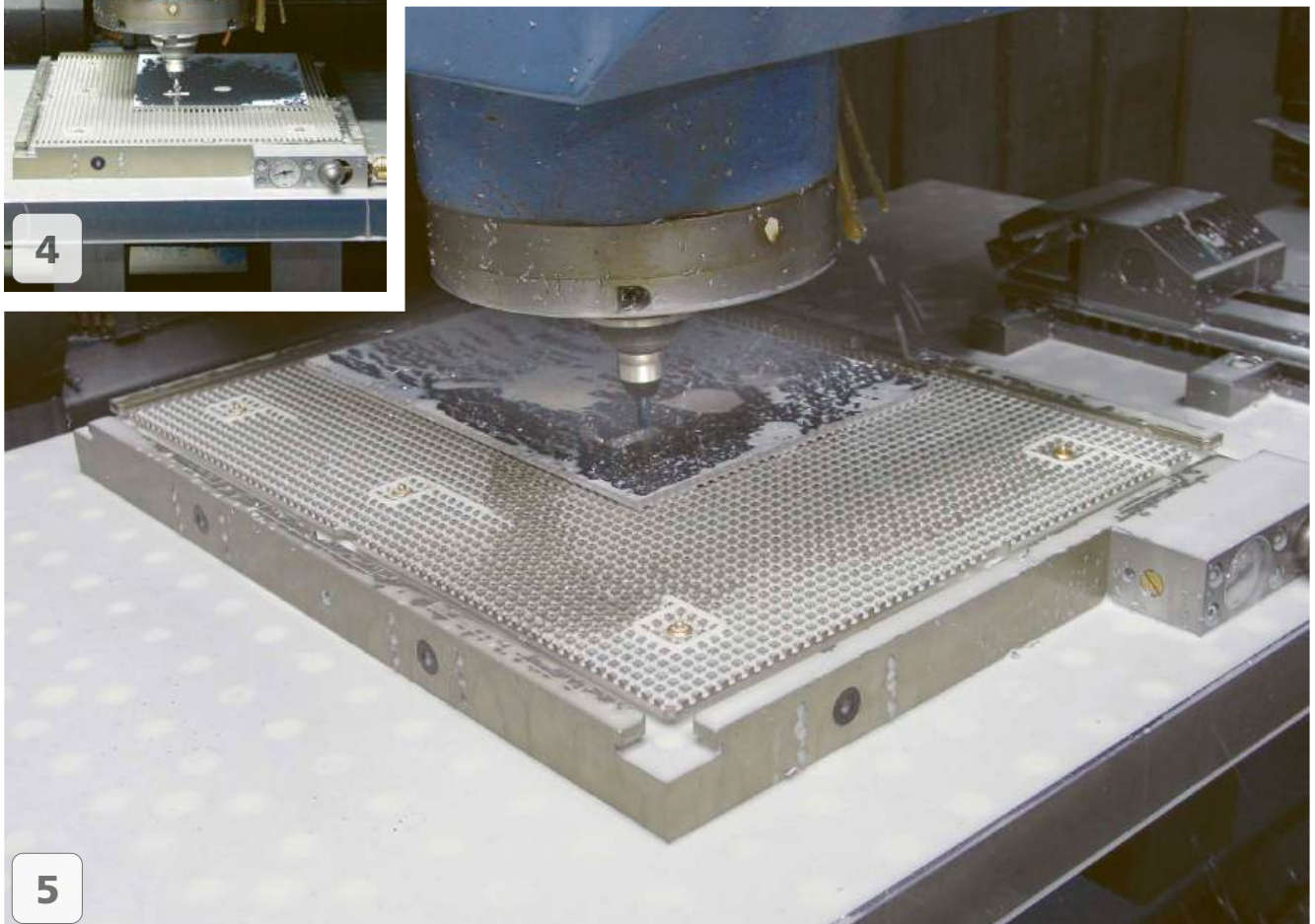
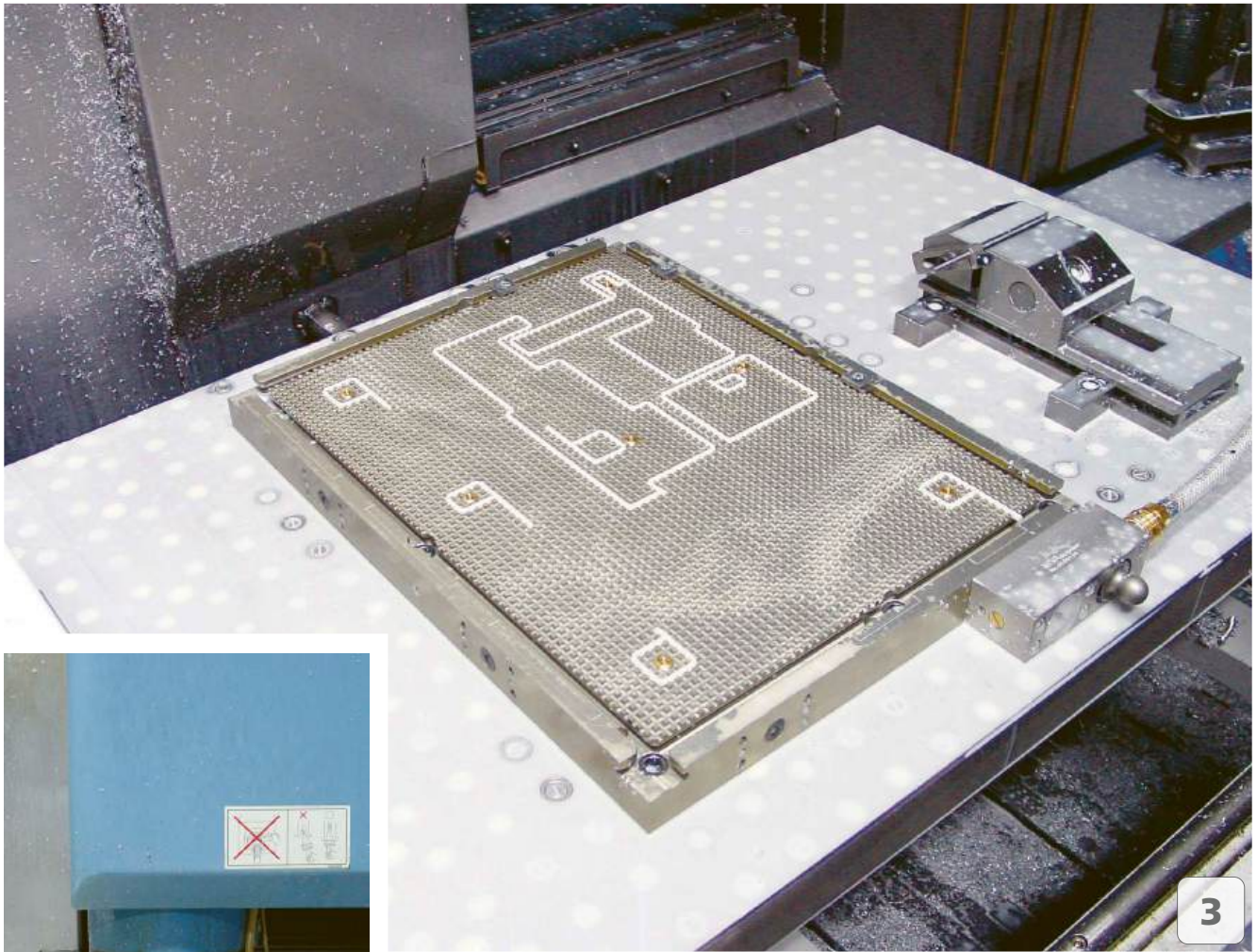

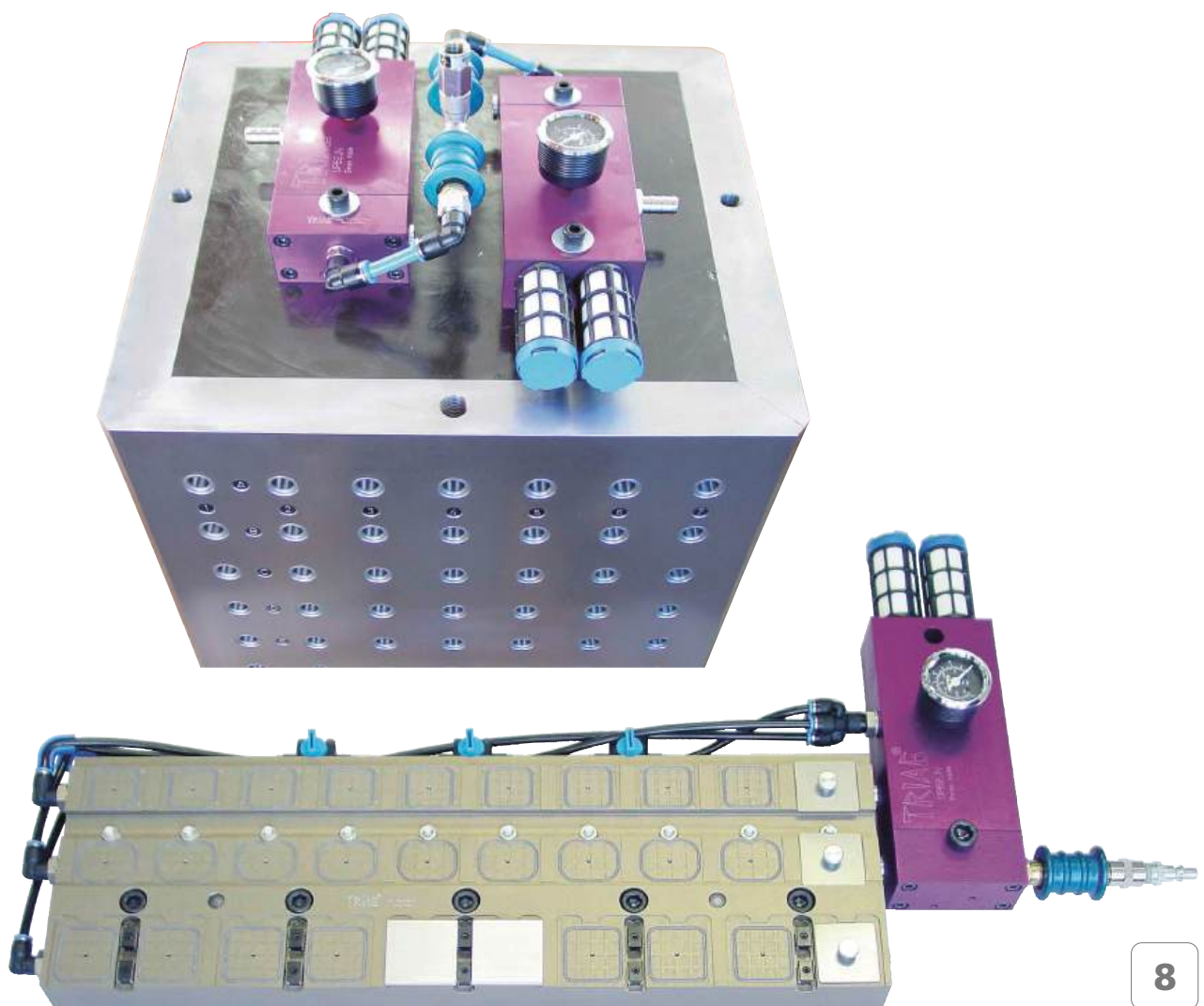
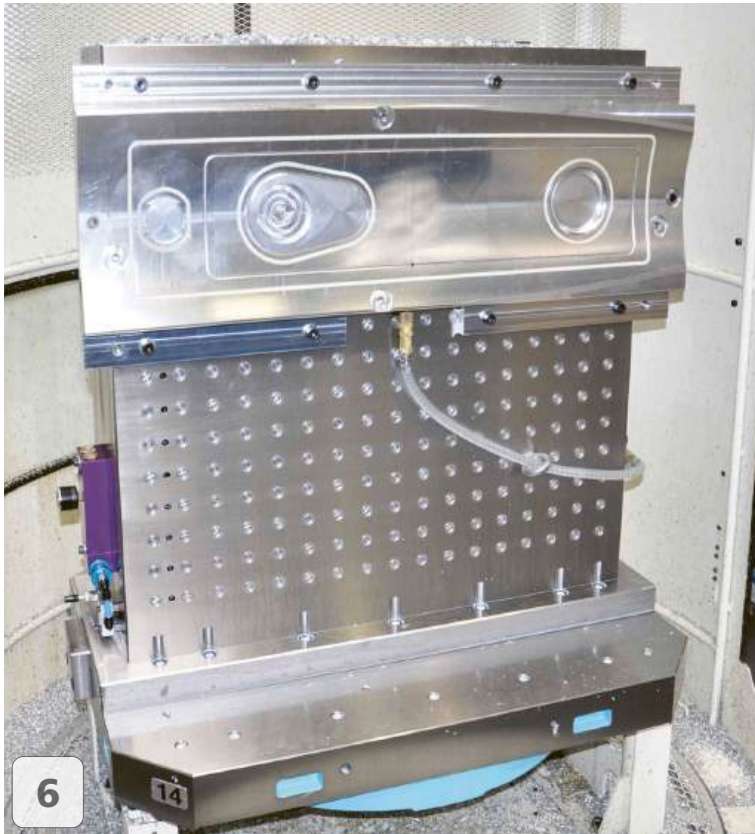



# Bestellschlüssel Vakuumplatten

Order code vacuum plates

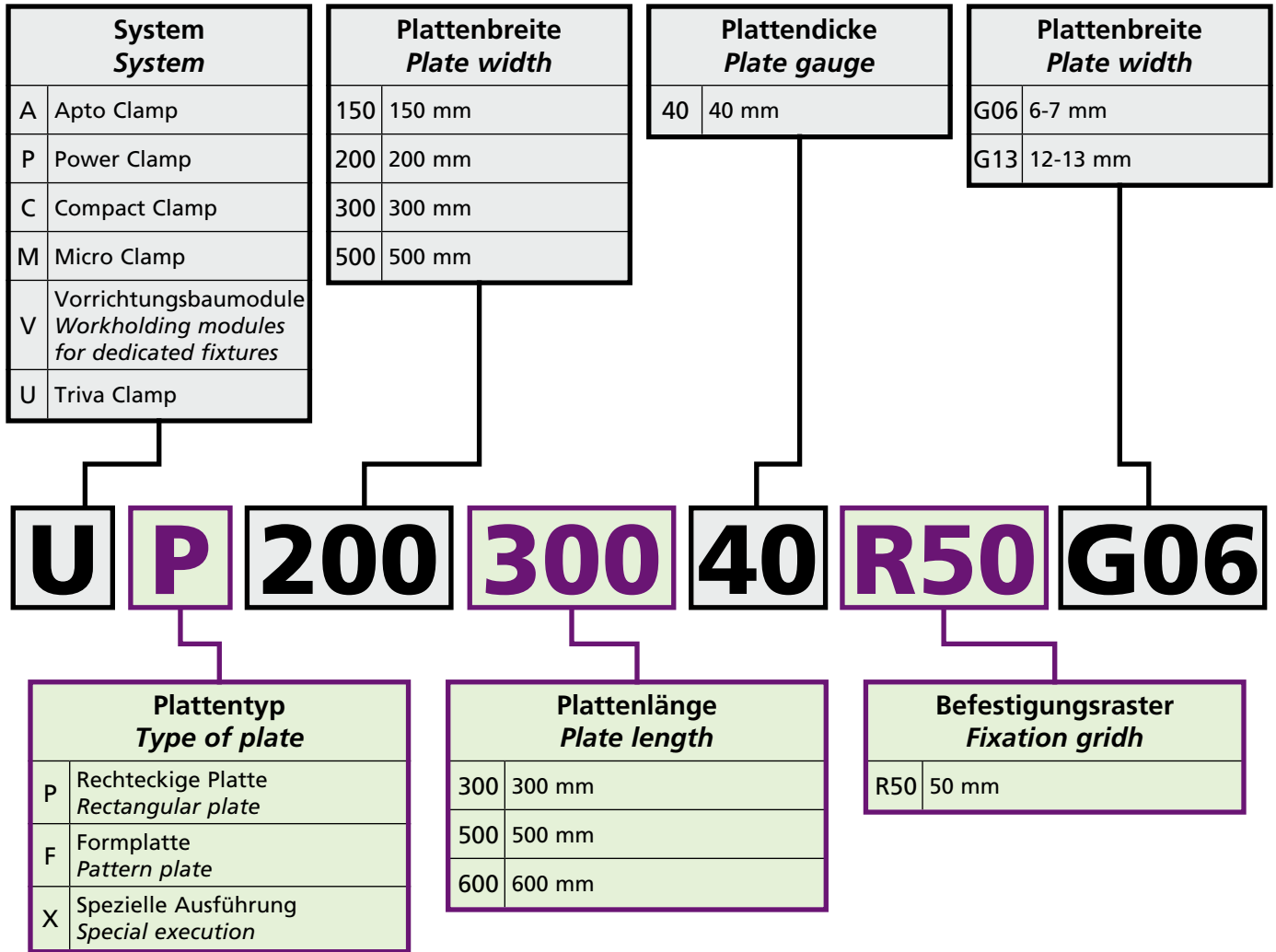
trivaCLAMP





**UF50050050R50...**

**Formplatten**

Für spezielle Werkstücke, die für das Spannen auf den Standardplatten ungeeignet sind, haben wir Rohplatten entwickelt, die bis zu 3 mal überfräst werden können. So lassen sich bis zu 3 verschiedene Werkstücke nacheinander bearbeiten.

**Die plates**

For special work pieces that are unsuitable for clamping on the standard plates, we have developed raw plates that can be milled again up to 3 times. This way, up to 3 different work pieces can be machined one after the other.

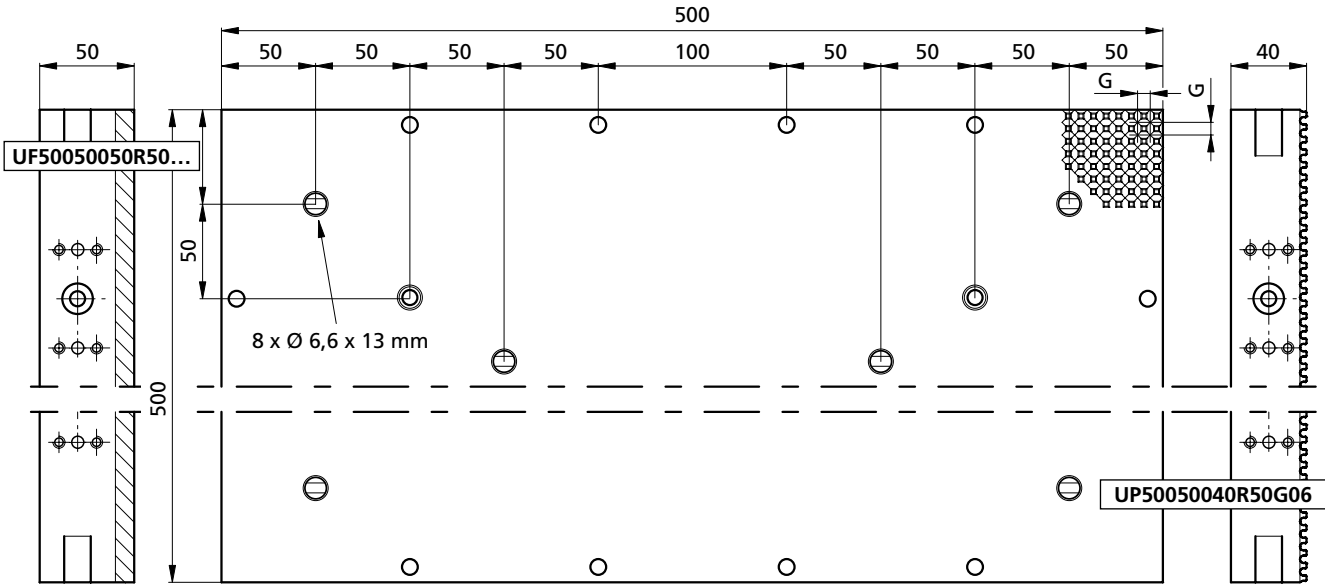

- G13**
- UP50050040R50G13**
- ① 1x TH160150
  - ② 4x 0700100
  - ③ 1x 1110100
  - ④ 15x 0920000
  - ⑤ 16x 1111003
  - ⑥ 16x M10X12ISO4027
  - ⑦ 8x M6X45ISO4762
  - ⑧ 1x 0910001
  - ⑨ 8x 0700102
- G = 12,5 mm  
kg ~24

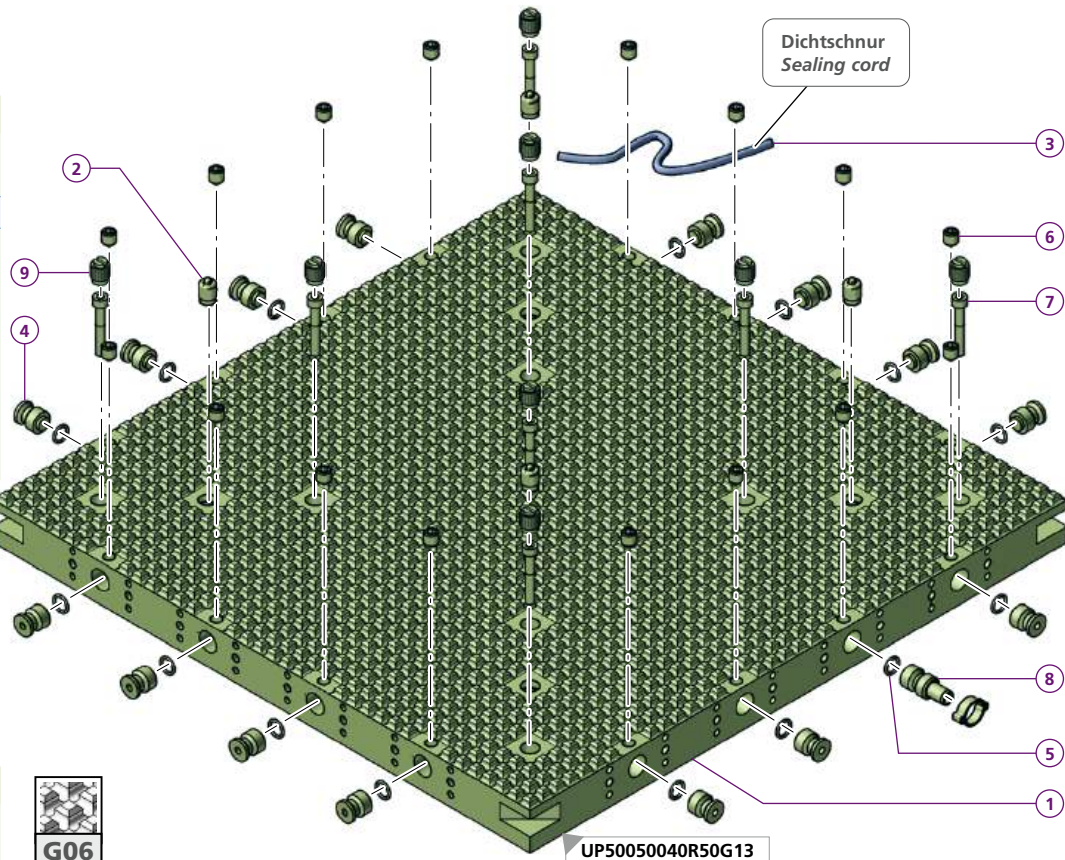

- UF50050050R50...**
- ① 1x TH160151
  - ② 4x 0700100
  - ③ 1x
  - ④ 15x 0920000
  - ⑤ 16x 1111003
  - ⑥ 16x M10X12ISO4027
  - ⑦ 8x M6X45ISO4762
  - ⑧ 1x 0910001
  - ⑨ 8x 0700102
- kg ~32,5

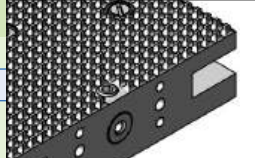
- G06**
- UP50050040R50G06**
- ① 1x TB160159
  - ③ 1x 1120100
- G = 6,5 mm  
kg ~26
- 

**Profilfräser / Carbide end mills G13 / G06 p. 324**  
Dichtschnüre je nach Bedarf / Sealing cords as needed

**Bestellbeispiel / Ordering example:**  
**UP50050040R50G13 & 1x 1110100**

Separat bestellen / Order separately

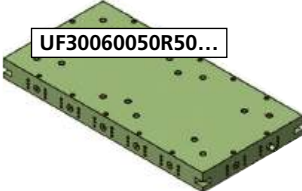

**UF30060050R50...**

**Formplatten**

Für spezielle Werkstücke, die für das Spannen auf den Standardplatten ungeeignet sind, haben wir Rohplatten entwickelt, die bis zu 3 mal überfräst werden können. So lassen sich bis zu 3 verschiedene Werkstücke nacheinander bearbeiten.

**Die plates**

For special work pieces that are unsuitable for clamping on the standard plates, we have developed raw plates that can be milled again up to 3 times. This way, up to 3 different work pieces can be machined one after the other.

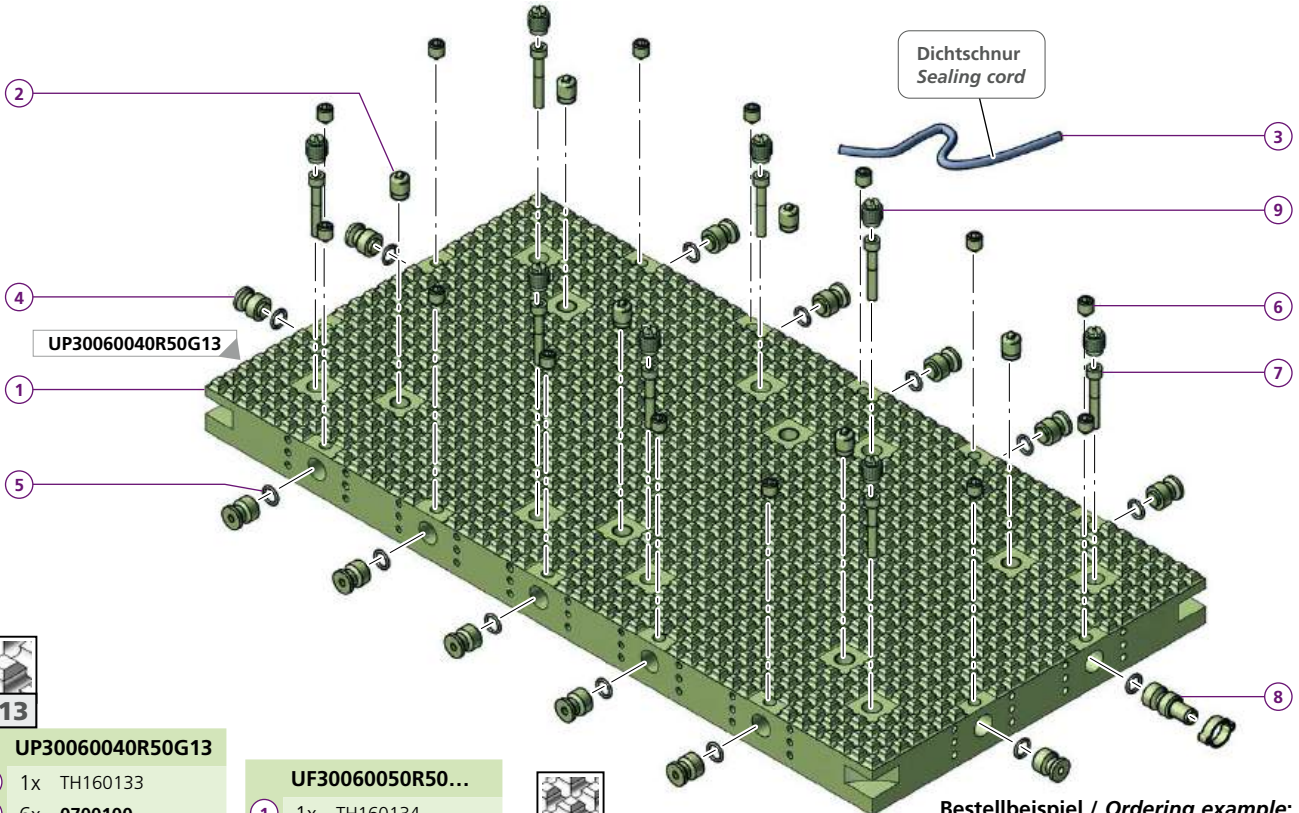
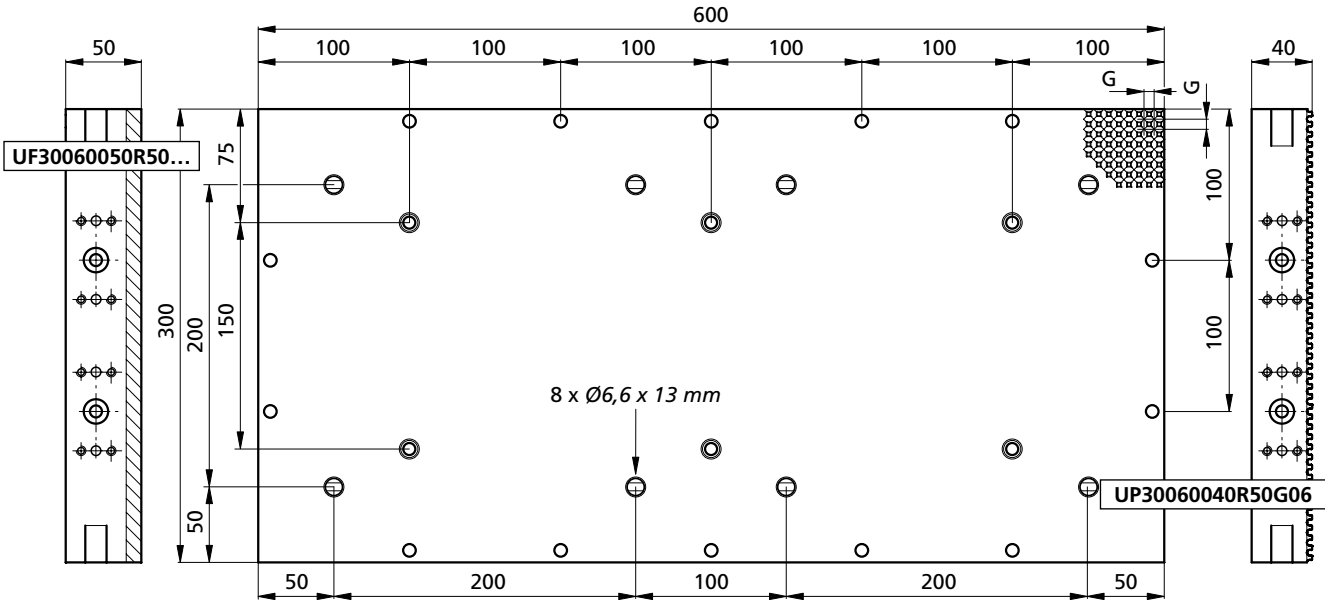

UP30060040R50G13	
1	1x TH160133
2	6x 0700100
3	1x 1110100
4	13x 0920000
5	13x 1111003
6	14x M10X12ISO4027
7	8x M6X45ISO4762
8	1x 0910001
9	8x 0700102
G	= 12,5 mm
kg	~18

UF30060050R50...	
1	1x TH160134
2	6x 0700100
3	1x
4	13x 0920000
5	13x 1111003
6	14x M10X12ISO4027
7	8x M6X45ISO4762
8	1x 0910001
9	8x 0700102
kg	~24,36



UP30060040R50G06	
1	1x TH120176
3	1x 1120100
G	= 6,5 mm
kg	~18,5

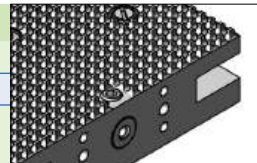

Bestellbeispiel / Ordering example:  
UP30060040R50G13 & 1x 1110100

Profilfräser / Carbide end mills G13 / G06 p. 324

Dichtsnüre je nach Bedarf / Sealing cords as needed

Separat bestellen / Order separately

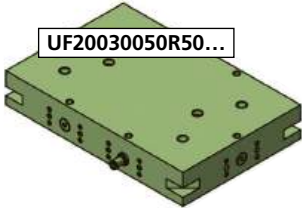

**UF20030050R50...**

**Formplatten**

Für spezielle Werkstücke, die für das Spannen auf den Standardplatten ungeeignet sind, haben wir Rohplatten entwickelt, die bis zu 3 mal überfräst werden können. So lassen sich bis zu 3 verschiedene Werkstücke nacheinander bearbeiten.

**Die plates**

For special work pieces that are unsuitable for clamping on the standard plates, we have developed raw plates that can be milled again up to 3 times. This way, up to 3 different work pieces can be machined one after the other.

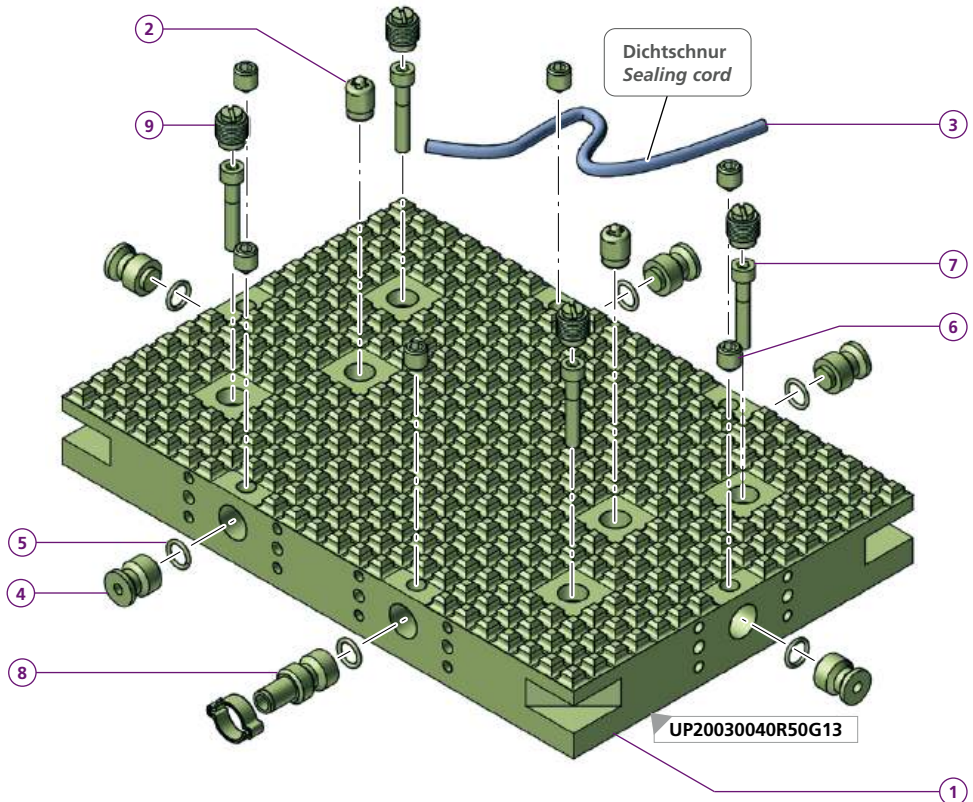
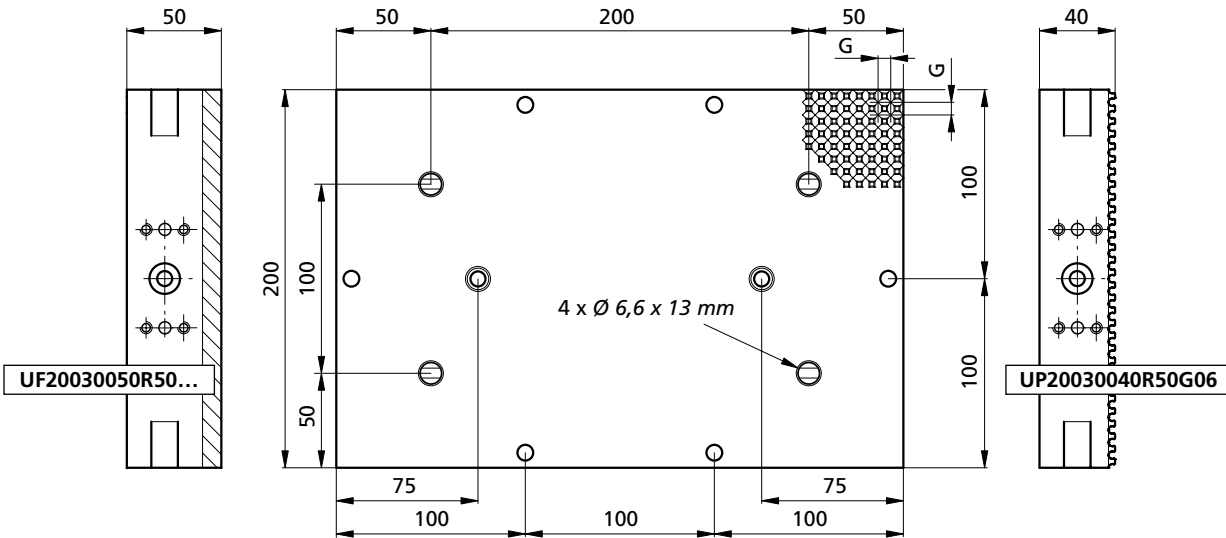

UP20030040R50G13	
1	1x TH160135
2	2x 0700100
3	1x 1110100
4	5x 0920000
5	6x 1111003
6	6x M10X12ISO4027
7	4x M6X45ISO4762
8	1x 0910001
9	4x 0700102
G	= 12,5 mm
kg	~5,5



UP20030040R50G06	
1	1x TH120175
3	1x 1120100
G	= 6,5 mm
kg	~6,0

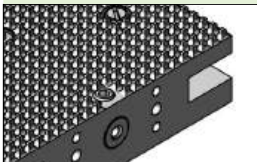

UF20030050R50...	
1	1x TH160136
2	2x 0700100
3	1x
4	5x 0920000
5	6x 1111003
6	6x M10X12ISO4027
7	4x M6X45ISO4762
8	1x 0910001
9	4x 0700102
kg	~8,09

**Bestellbeispiel / Ordering example:**  
**UP20030040R50G13 & 1x 1110100**

**Profilfräser / Carbide end mills G13 / G06 p. 324**

Dichtschnüre je nach Bedarf / Sealing cords as needed

Separat bestellen / Order separately



**Formplatten**

Für spezielle Werkstücke, die für das Spannen auf den Standardplatten ungeeignet sind, haben wir Rohplatten entwickelt, die bis zu 3 mal überfräst werden können. So lassen sich bis zu 3 verschiedene Werkstücke nacheinander bearbeiten.

**Die plates**

For special work pieces that are unsuitable for clamping on the standard plates, we have developed raw plates that can be milled again up to 3 times. This way, up to 3 different work pieces can be machined one after the other.

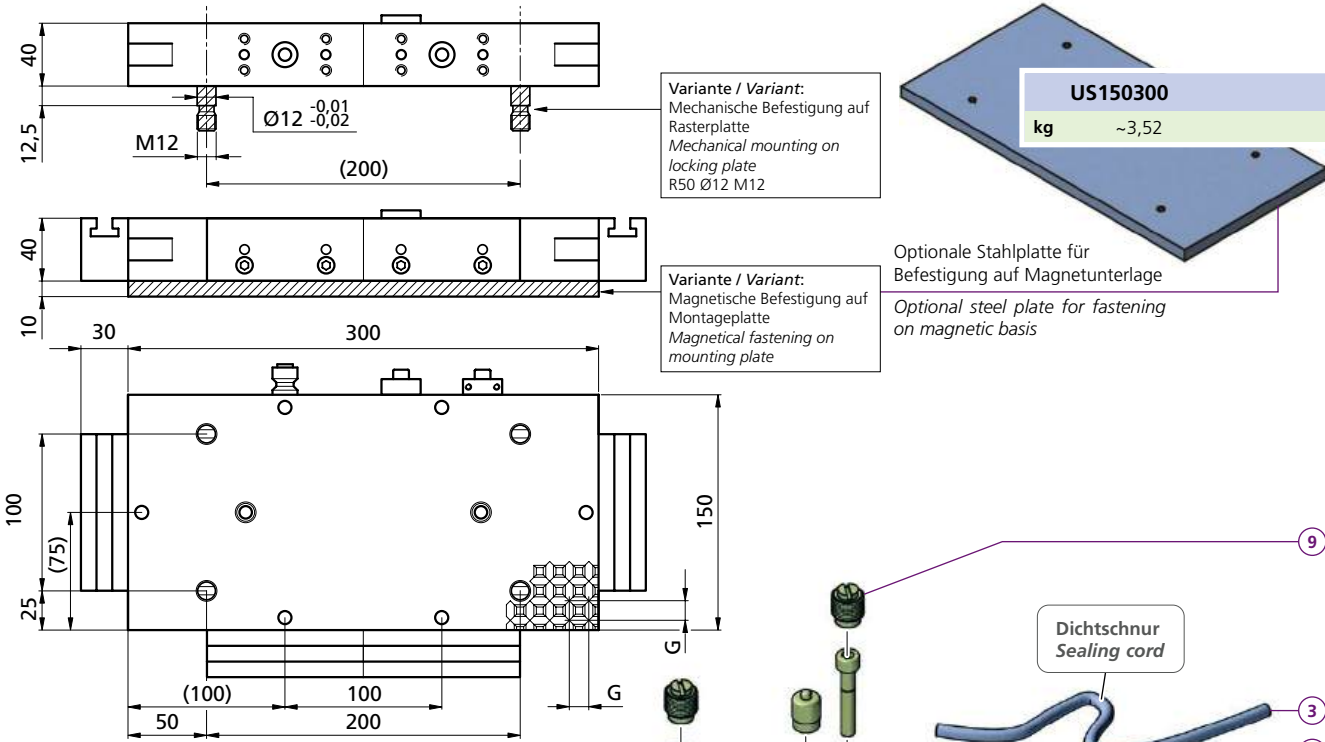

**G13**

**UP15030040R50G13**

1	1x TF210975_A
2	2x 0700100
3	1x 1110100
4	5x 0920000
5	6x 1111003
6	6x M10X12ISO4027
7	4x M6X35ISO4762
8	1x 0910001
9	4x 0700102
10	4x ADAPT6-12

G = 12,5 mm  
kg ~4,6

**G06**

**UP15030040R50G06**

1	1x TB210978_A
3	1x 1120100

G = 6,5 mm  
kg ~4,8

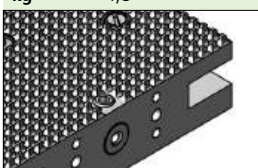

**UF15030050R50**

1	1x TH160131
2	2x 0700100
3	1x
4	5x 0920000
5	6x 1111003
6	6x M10X12ISO4027
7	4x M6X35ISO4762
8	1x 0910001
9	4x 0700102

kg ~6

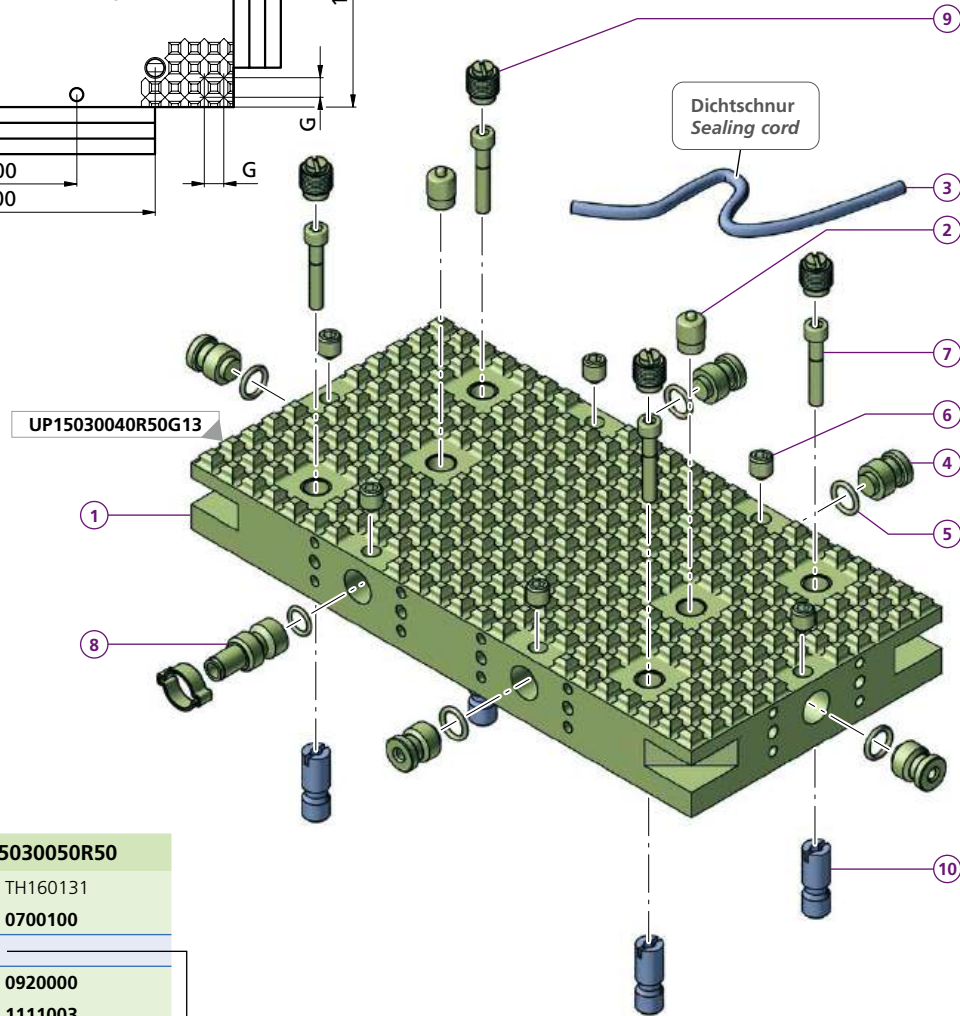

**Bestellbeispiel / Ordering example:**  
**UP15030040R50G13** & 1x **ADAPT6-12** & 1x **1110100**

**Profilfräser / Carbide end mills G13 / G06 p. 324**

Dichtschnüre je nach Bedarf / Sealing cords as needed

Separat bestellen / Order separately

Vakuum-Modul für powerCLAMP  
 Vacuum module for powerCLAMP

PS1X150L60-VAC trivaCLAMP

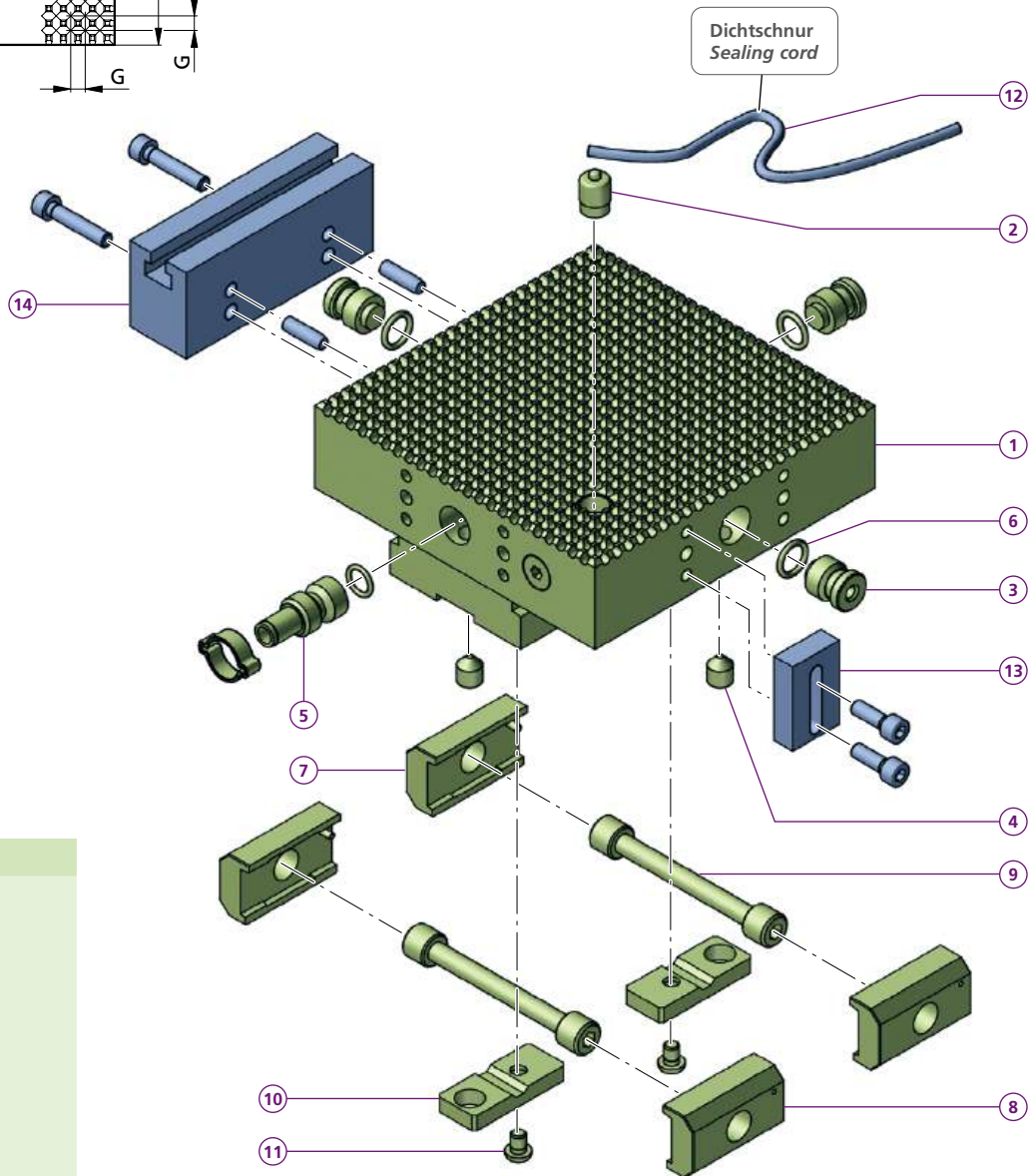
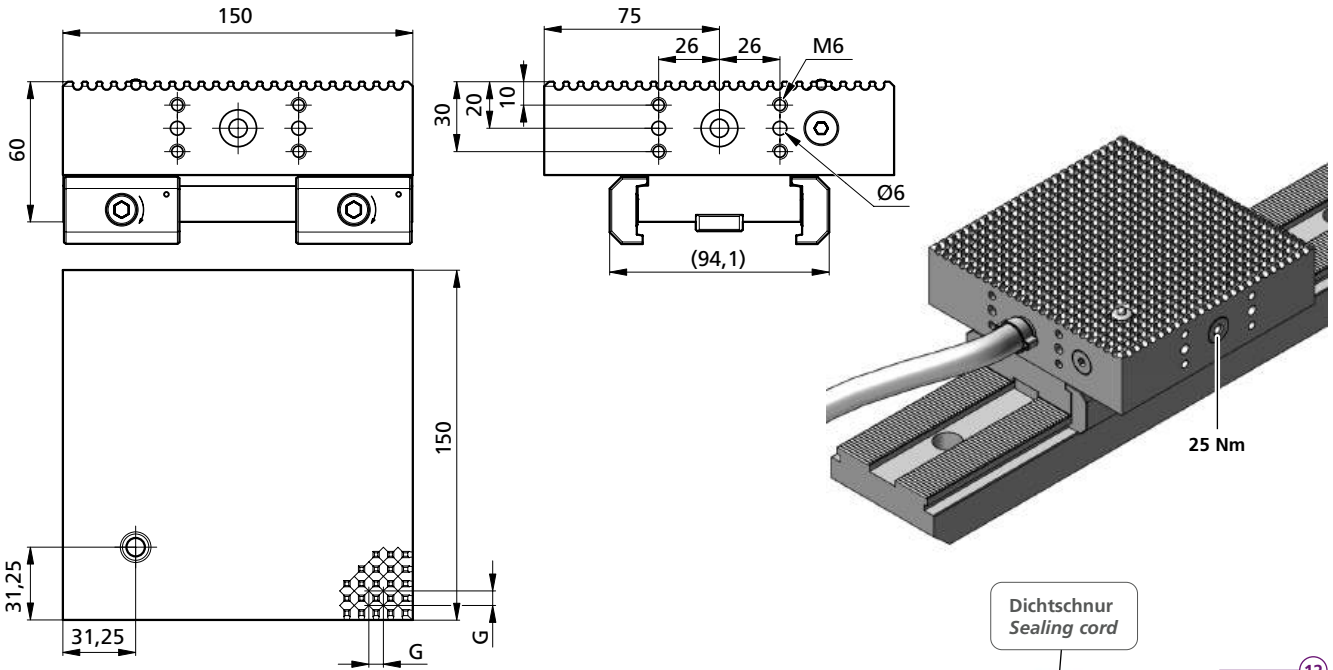

PS1X150L60-VAC

1	1x TW090017-01	
2	1x 0700100	
3	3x 0920000	
4	4x M10X12ISO4027	
5	1x 0910001	
6	5x 1111003	
7	2x PCSP50R	
8	2x PCSP50L	
9	2x PCS14	
10	2x PCGU2049	
11	2x M6X8ISO7380	
12	1x 1120100	p. 324
13	1x UA182540	p. 322
14	1x UT1003040	
G	= 6,5 mm	
kg	~3,6	

Bestellbeispiel / Ordering example:  
 PS1X150L60-VAC & 1x 1120100 & 1x UA182540 & 1x UT1003040

Separat bestellen / Order separately

# Vakuum-Modul für powerCLAMP Vacuum module for powerCLAMP

PS1X80L31-VAC

trivaCLAMP

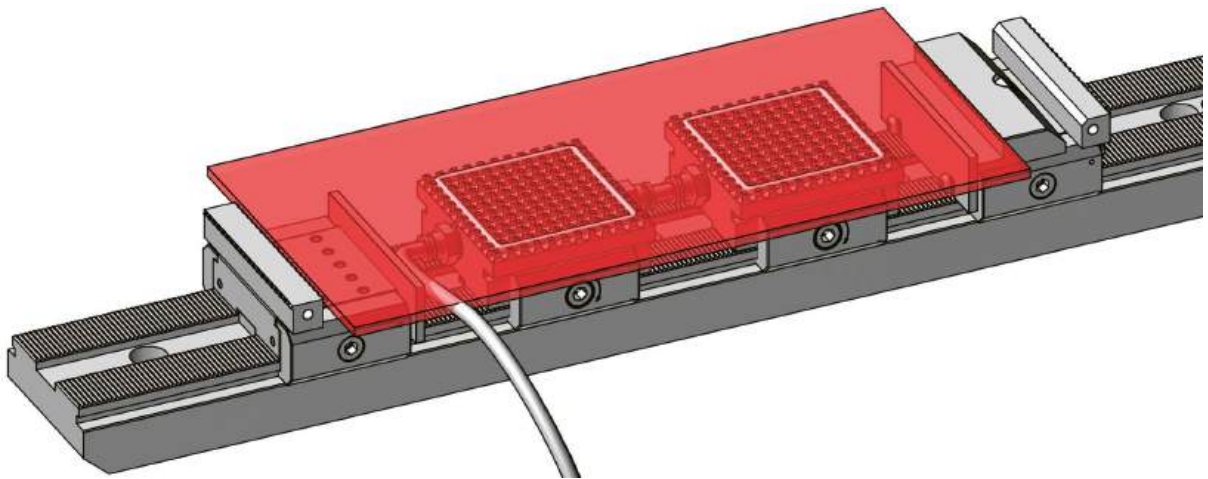
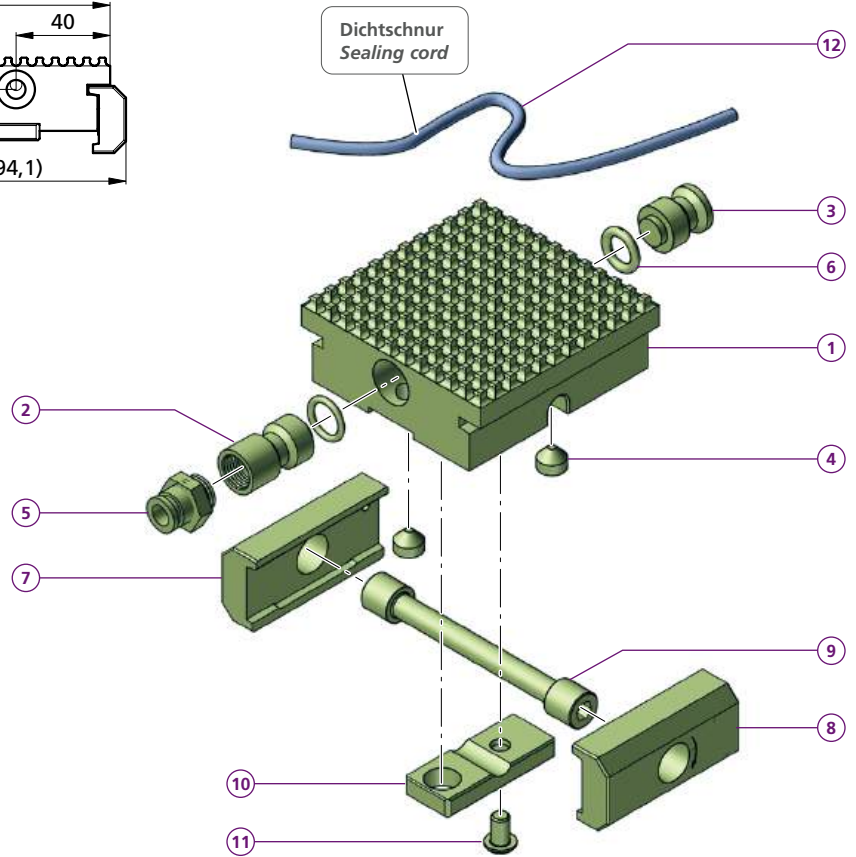
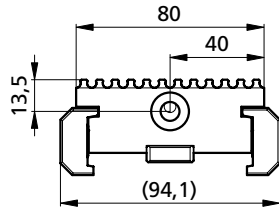
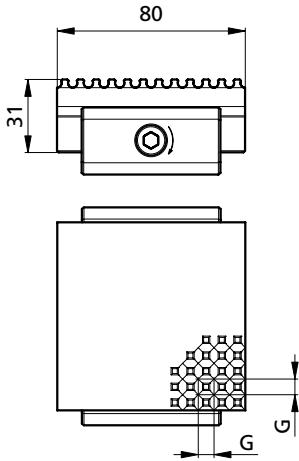

## PS1X80L31-VAC

- ① 1x TH140263
- ② 1x UZV16301/4
- ③ 1x 0920000
- ④ 2x M10X8DIN914
- ⑤ 1x QSG1/4-8
- ⑥ 2x 1111003
- ⑦ 1x PCSP60R
- ⑧ 1x PCSP60L
- ⑨ 1x PCS14
- ⑩ 1x PCGU2049
- ⑪ 1x M6X8ISO7380
- ⑫ 1x 1120100

G = 6,5 mm  
kg ~0,62

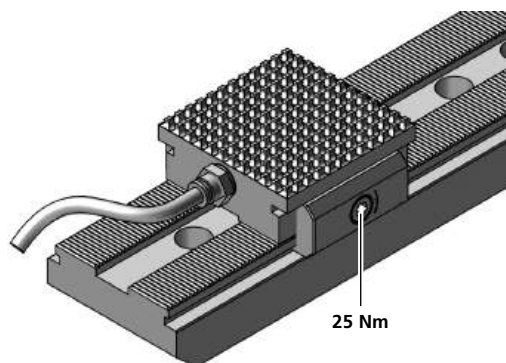

Bestellbeispiel / Ordering example: PS1X80L31-VAC & 1x 1120100

Separat bestellen / Order separately

# Kombinationsvarianten (Vakuumpplatten)

## Possible combination of vacuum plates

trivaCLAMP

### UP15030040R50 G06 / G13

Platte / Plate

1 x = 150 x 300

2 x = 150 x 600

2 x = 300 x 300

4 x = 300 x 600

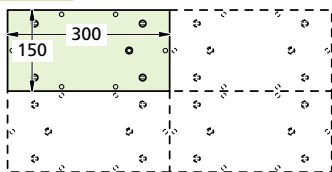

3 x = 300 x 450

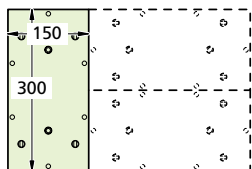

### UP20030040R50 G06 / G13

Platte / Plate

1 x = 200 x 300

2 x = 200 x 600

4 x = 400 x 600

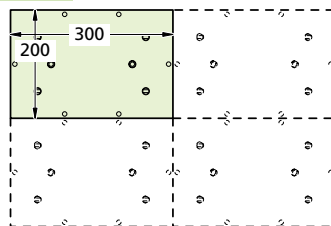

3 x = 300 x 600

4 x = 300 x 800

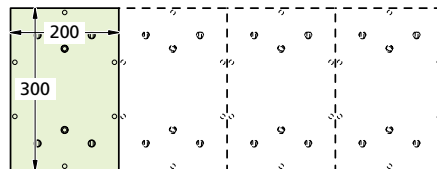

### UP30060040R50 G06 / G13

Platte / Plate

1 x = 300 x 600

2 x = 600 x 600

3 x = 600 x 900

4 x = 600 x 1200

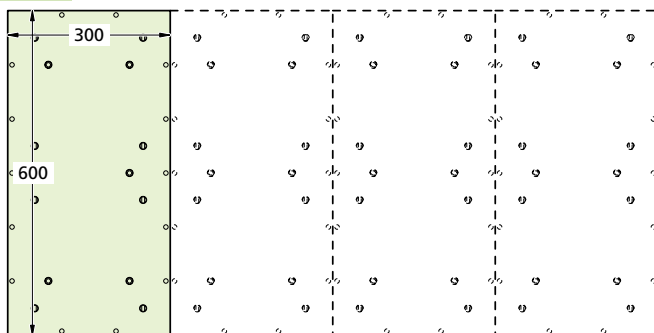

### UP30060040R50 G06 / G13

Platte / Plate

1 x = 300 x 600

UP20030040R50 G06 / G13

Platte / Plate

2 x = 200 x 300

= 500 x 600

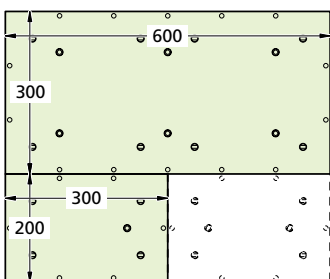

### UP30060040R50 G06 / G13

Platte / Plate

2 x = 300 x 600

UP20030040R50 G06 / G13

Platte / Plate

2 x = 200 x 300

= 600 x 800

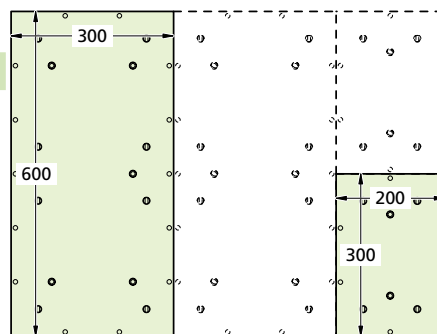

### UP50050040R50 G06 / G13

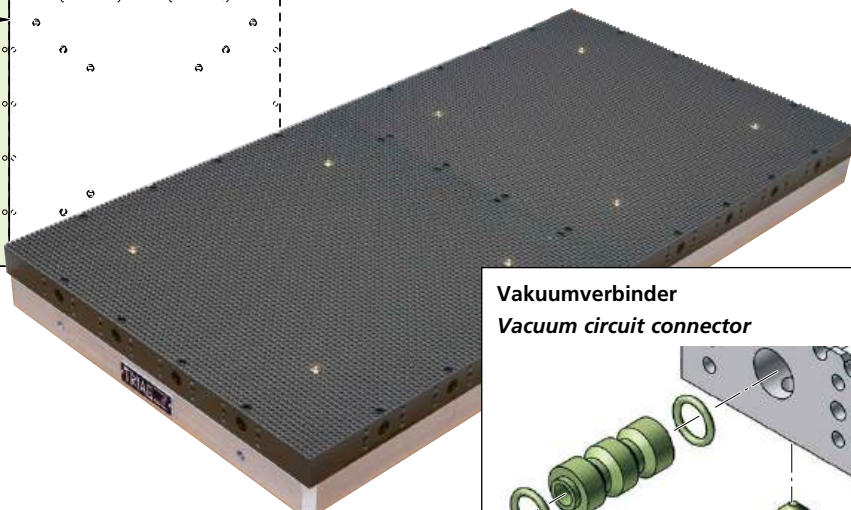
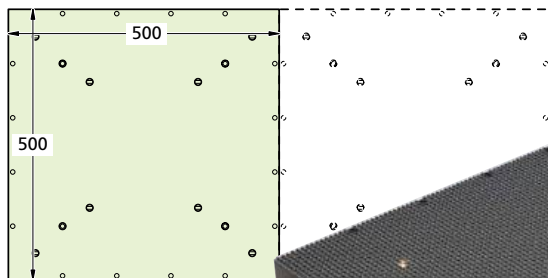

Platte / Plate

2 x = 500 x 1000

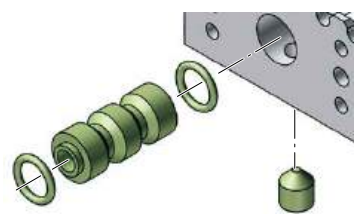

Vakuumverbinder  
Vacuum circuit connector

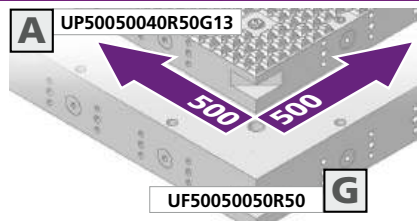
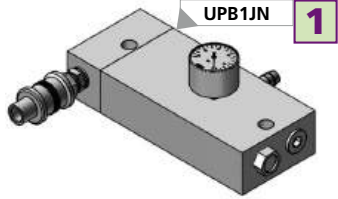
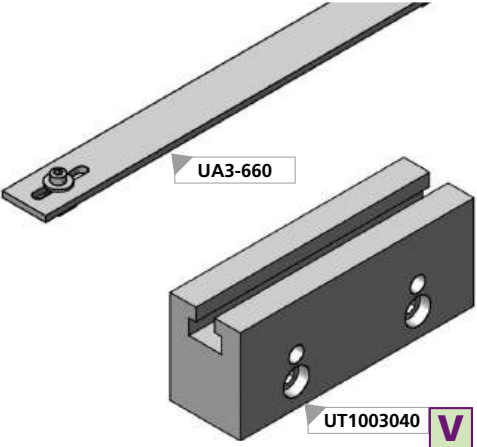
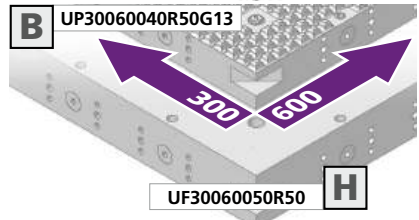
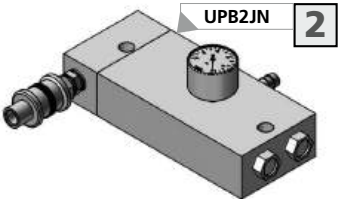
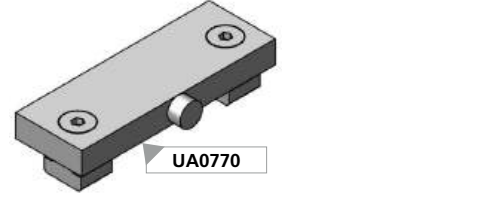
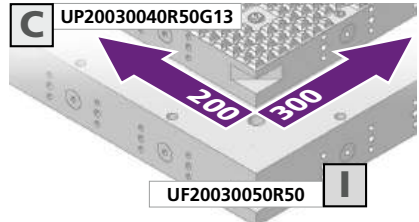
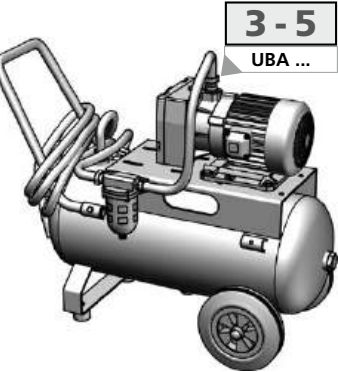
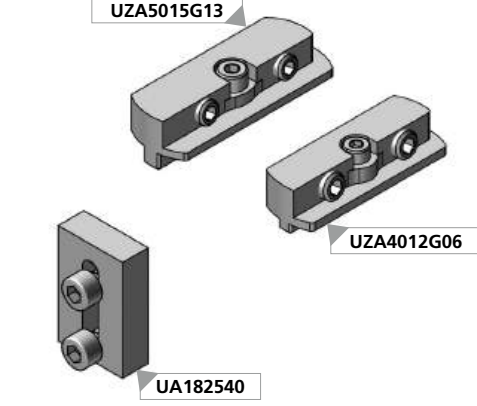
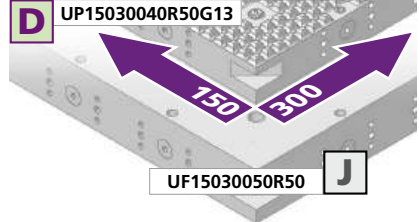
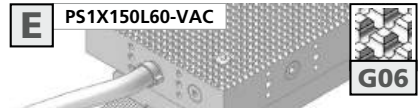
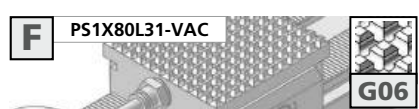

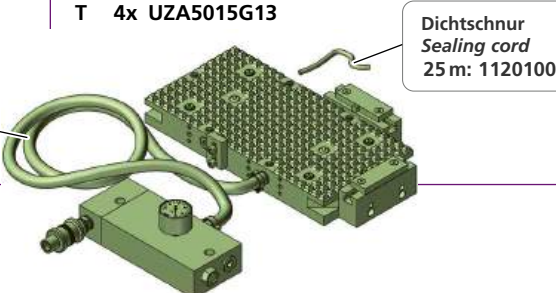
UPSET	D	1	V	G...
 <p><b>A</b> UP50050040R50G13 500 500 UF50050050R50 <b>G</b></p>		 <p><b>1</b> UPB1JN <b>1</b></p>	 <p>UA3-660 UT1003040 <b>V</b></p>	
 <p><b>B</b> UP30060040R50G13 300 600 UF30060050R50 <b>H</b></p>		 <p><b>2</b> UPB2JN <b>2</b></p>	 <p>UA0770</p>	
 <p><b>C</b> UP20030040R50G13 200 300 UF20030050R50 <b>I</b></p>		 <p><b>3-5</b> UBA ...</p>	 <p>UZA5015G13 UZA4012G06 UA182540</p>	
 <p><b>D</b> UP15030040R50G13 150 300 UF15030050R50 <b>J</b></p>				
 <p><b>E</b> PS1X150L60-VAC <b>G06</b></p>				
 <p><b>F</b> PS1X80L31-VAC <b>G06</b></p>				
 <p><b>G13</b> <b>G06</b></p>				
<p><b>Vakuumpalte Vacuum plate</b></p>	<p><b>Vakuum erzeugen Generate vacuum</b></p>	<p><b>Zubehör Accessories</b></p>		
<p><b>A</b> 500 x 500 (UP50050040R50 G06 / G13)  <b>B</b> 300 x 600 (UP30060040R50 G06 / G13)  <b>C</b> 200 x 300 (UP20030040R50 G06 / G13)  <b>D</b> 150 x 300 (UP15030040R50 G06 / G13)  <b>E</b> 150 x 60 (PS1X150L60-VAC)  <b>F</b> 80 x 31 (PS1X80L31-VAC)  <b>G</b> 500 X 500 (UF50050050R50)  <b>H</b> 300 X 600 (UF30060050R50)  <b>I</b> 200 X 300 (UF20030050R50)  <b>J</b> 150 X 300 (UF15030050R50)</p>	<p><b>1</b> UPB1JN  <b>2</b> UPB2JN  <b>3</b> UBA106230300  <b>4</b> UBA106110250  <b>5</b> UBA318400550</p>	<p><b>Z</b> 2x UT1003040 1x UA182540 1x UA3-660  <b>Y</b> 2x UT1003040 1x UA182540 1x UA3-560  <b>X</b> 2x UT1003040 1x UA182540 1x UA3-360  <b>W</b> 2x UT1003040 1x UA182540 1x UA2-260  <b>V</b> 2x UT1003040 1x UA182540 2x UA0770  <b>U</b> 4x UZA4012G06  <b>T</b> 4x UZA5015G13</p>	 <p>Vakuumschlauch Vacuum hose 3 m: 0941000</p> <p>Dichtschnur Sealing cord 25 m: 1120100</p>	
<p>Zu jedem SET werden zusätzlich 3 m Vakuumschlauch (0941000) und 25 m Dichtschnur mitgeliefert (1120100) Ø 4 oder (1110100) 6 mm inkl. (2 x 10100024).              Each SET is supplied with an additional 3 m vacuum hose (0941000) and 25 m sealing cord (1120100) Ø 4 or (1110100) 6 mm incl. (2 x 10100024).</p>				
<p>Bestellbeispiel / Ordering example: <b>UPSETD1VG13</b></p>				

Anschlagleisten  
Stop rails

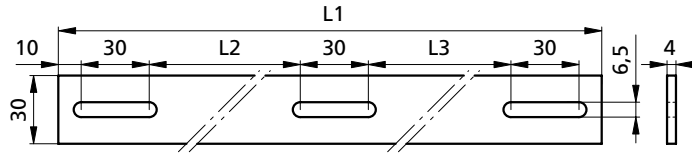

UA3-660	
1	1x TH160274
2	3x M6X12ISO4762
3	3x 6,4 DIN9021
4	3x SM1135M6X8
L1	= 660 mm
L2	= 270 mm
L3	= 280 mm
kg	~0,6

UA3-560	
1	1x TH160275
2	3x M6X12ISO4762
3	3x 6,4 DIN9021
4	3x SM1135M6X8
L1	= 560 mm
L2	= 225 mm
L3	= 225 mm
kg	~0,5

UA3-360	
1	1x TH160277
2	3x M6X12ISO4762
3	3x 6,4 DIN9021
4	3x SM1135M6X8
L1	= 360 mm
L2	= 120 mm
L3	= 130 mm
kg	~0,32

UA2-260	
1	1x TH160278
2	2x M6X12ISO4762
3	2x 6,4 DIN9021
4	2x SM1135M6X8
L1	= 260 mm
L2	= 180 mm
L3	= 180 mm
kg	~0,2

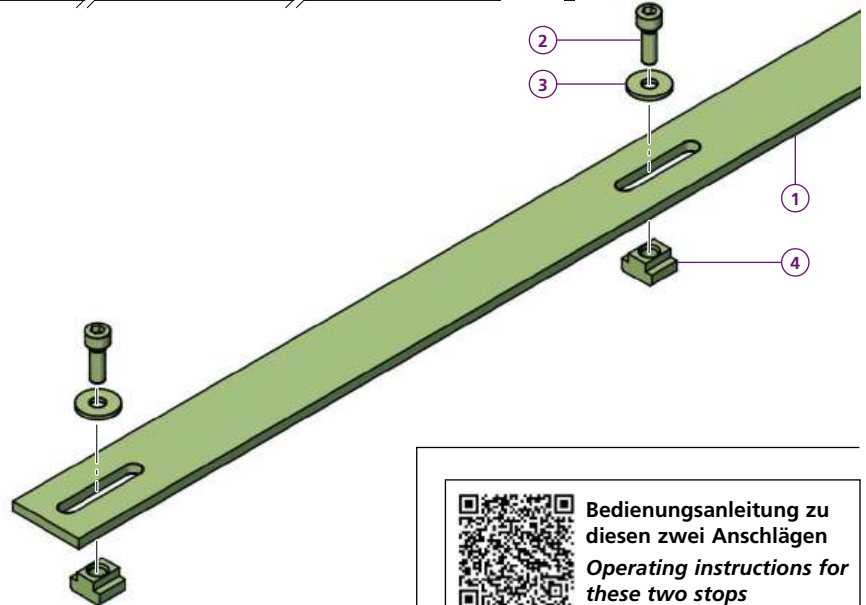

Bedienungsanleitung zu diesen zwei Anschlägen  
Operating instructions for these two stops

Anschlag  
Stop rail

UZA5015G13	
1	1x TB170561
2	1x M4X10ISO4762
3	2x M6x16 DIN913
4	1x TN100036
5	1x TB170562
L	= 50 mm
H	= 9 mm
kg	~0,04

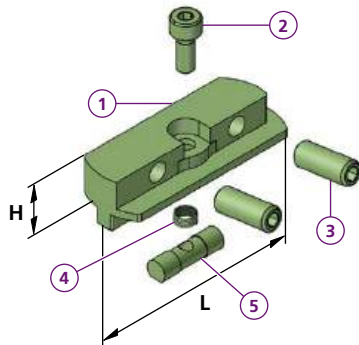

UZA4012G06	
1	1x TB170558
2	1x M3X8ISO4762
3	2x M6X12 DIN913
4	1x TN100036
5	1x TB170559
L	= 40 mm
H	= 8,5 mm
kg	~0,03

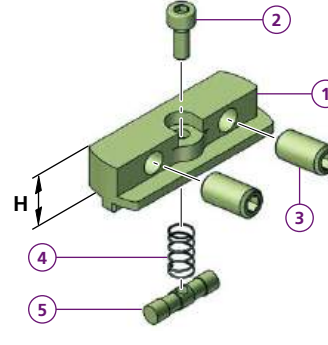

T-Nuten Stein  
T-nuts

0802000-SET	
1	1x M6X12ISO4762
2	1x SM1135M6X8
3	1x 6,4 DIN9021
kg	~0,03

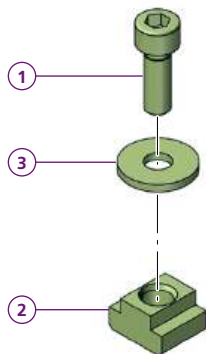

Ansetzbare T-Nuten  
Attachable T-slots

UT1003040	
1	1x TH160227
2	2x M6X25ISO4762
3	2x 6X20-B ISO8734
kg	~0,4

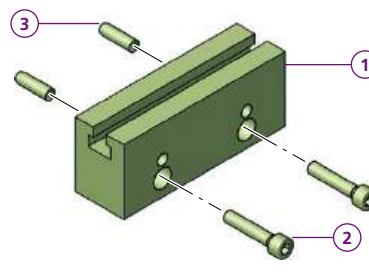

Seiten-/Wendeanschlag  
Reversible stop gage

UA0770	
1	1x TH160259
2	2x TN100899
3	2x SM1135M6X8
kg	~0,14

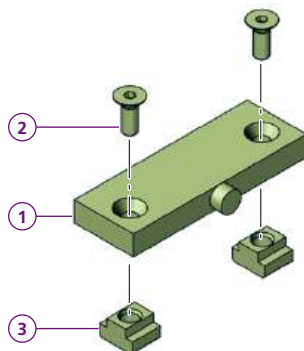

Seitenanschlag  
Side lay

UA182540	
1	1x TH160098
2	2x M6X18ISO4762
kg	~0,1

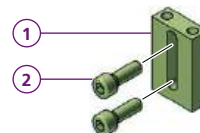

# Vakuumverbinder Vacuum circuit connector

# Koppelemente Link-up plug

# trivaCLAMP

## Vakuumverbinder Vacuum circuit connector

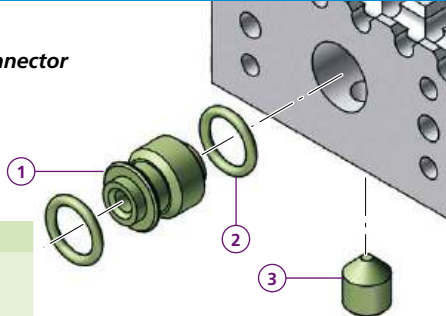

- 0930000**
- ① 1x TK110401
  - ② 2x 1111003
  - ③ 1x M10X12ISO4027
- kg ~0,02

## Blindstopfen Blind plug

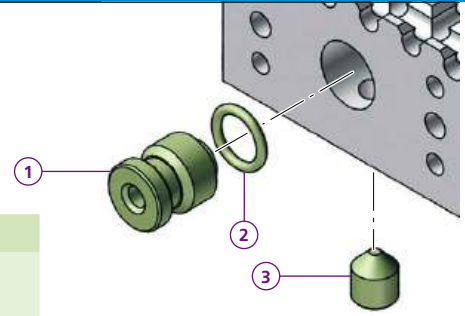

- 0920000**
- ① 1x TK110402
  - ② 1x 1111003
  - ③ 1x M10X12ISO4027
- kg ~0,03

## Koppelement Link-up plug

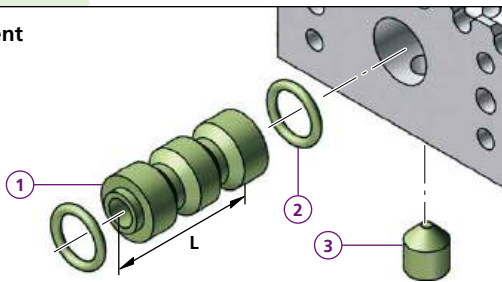

- 0910000**
- ① 1x TK110403
  - ② 2x 1111003
  - ③ 1x M10X12ISO4027
- L = 40 mm
- kg ~0,03

- 0910080**
- ① 1x TK140763
  - ② 2x 1111003
  - ③ 1x M10X12ISO4027
- L = 80 mm
- kg ~0,04

## Vakuumverbinder Vacuum circuit connector

- ZH170537**
- ① 1x TS150487
  - ② 2x TN100682
- d = 5,8 mm
- D = 15 mm

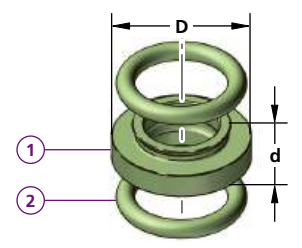

## Anschlüsselement Adapter element

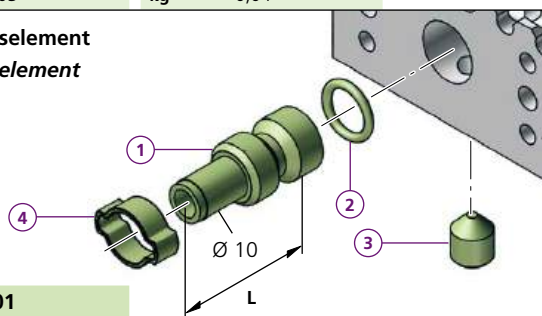

- 0910001**
- ① 1x TK110404
  - ② 1x 1111003
  - ③ 1x M10X12ISO4027
  - ④ 1x 10100024
- L = 40 mm
- kg ~0,04

## Vakuumschlauch (per Laufmeter) Vacuum hose (per running meter)

- D = 8 mm** für Vakuumanbindung von Platte zu Platte  
for vacuum supply from plates to accessories
- D = 16 mm** für Vakuumverbindung von Pumpe zu Platten  
for vacuum supply from pump to plate

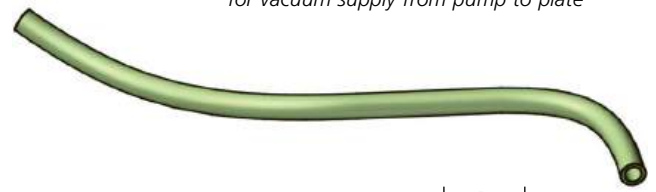

- |                |                |
|----------------|----------------|
| <b>0940800</b> | <b>0941000</b> |
| D = 8 mm       | D = 16 mm      |
| d = 5,5 mm     | d = 10 mm      |

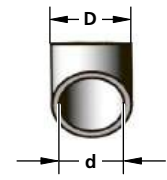

## Vakuumverbinder Vacuum circuit connector

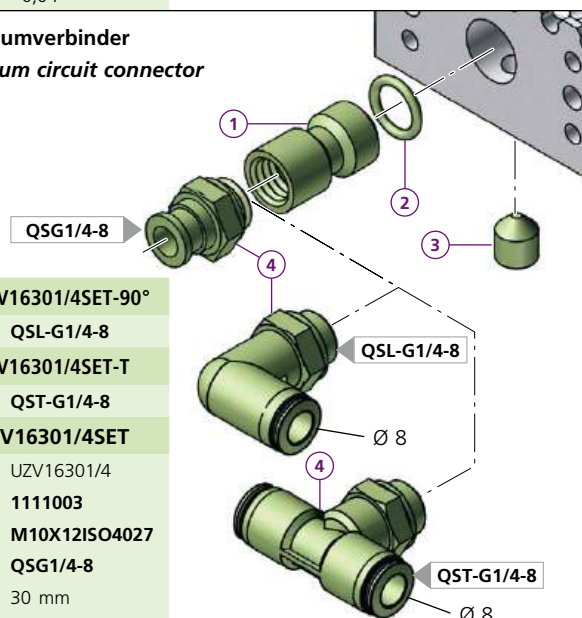

- UZV16301/4SET-90°**
- ④ 1x QSL-G1/4-8
- UZV16301/4SET-T**
- ④ 1x QST-G1/4-8
- UZV16301/4SET**
- ① 1x UZV16301/4
  - ② 1x 1111003
  - ③ 1x M10X12ISO4027
  - ④ 1x QSG1/4-8
- L = 30 mm
- kg ~0,024

## Verbindungsschlauch mit Koppelementen Connector-tube with link-ups

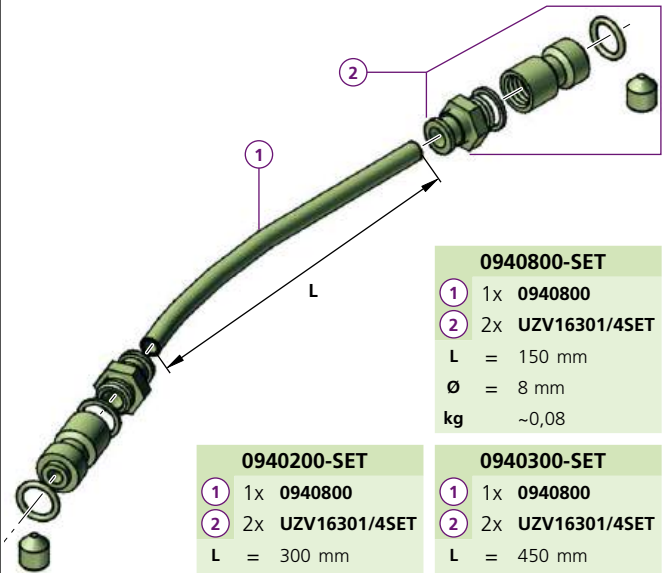

- 0940800-SET**
- ① 1x 0940800
  - ② 2x UZV16301/4SET
- L = 150 mm
- Ø = 8 mm
- kg ~0,08

- 0940200-SET**
- ① 1x 0940800
  - ② 2x UZV16301/4SET
- L = 300 mm
- Ø = 8 mm
- kg ~0,08

- 0940300-SET**
- ① 1x 0940800
  - ② 2x UZV16301/4SET
- L = 450 mm
- Ø = 8 mm
- kg ~0,09

### Dichtschnüre aus Silikon-Gummi

Beständig gegen Öle, Säuren, Emulsionen, Dielektrika, ionisiertes Wasser und Wärme bis 200°C

### Silicone-rubber sealing cord

Resistant to oils, acids, coolants, dielectrics, activated water (EDM) and heat up to 200°C

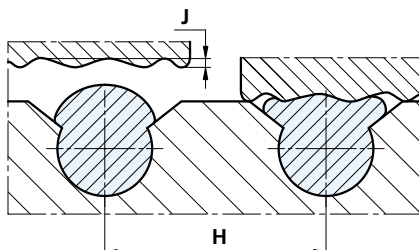

### Dichtschnüre aus Gummi

- ölbeständig  
- für spezielle Vorrichtungen

### Rubber sealing cord

- oil resistance  
- to fit special devices

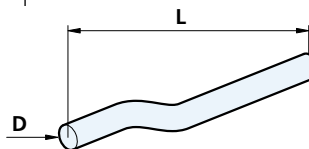

weiss / white

G13	G06	weiss / white	
<b>1110100</b>	<b>1120100</b>	<b>1120100M</b>	<b>1130000</b>
L = 25 m	L = 25 m	L = 25 m	L = 5 m
D = 6,5 mm ±0,5	D = 4 mm (4,3-4,6 mm)	D = 4 mm (4,0-4,3 mm)	D = 3 mm
J = max. 0,6 mm	J = max. 0,4 mm	J = max. 0,3 mm	
H = 12-13 mm	H = 6-7 mm	H = 6-7 mm	



schwarz / black

weiss / white

G13	schwarz / black		weiss / white	
<b>1110100S</b>	<b>1110100SP</b>	<b>0130001</b>	<b>0130002</b>	
L = 25 m	L = 25 m	L = 1 m	L = 1 m	
D = 6,0-6,5 mm	D = 6,6-7,0 mm	D = 2,15 mm	D = 1,65 mm	
J = max. 0,6 mm	J = max. 0,6 mm			
H = 12-13 mm	H = 12-13 mm			

### Triva Clamp Ventil / Triva Clamp valve

Montage von oben  
Mounting from above

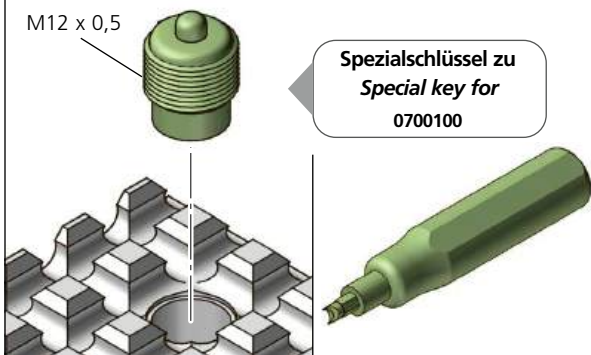

<b>0700100</b>	kg	~0,01	<b>Triva Bit</b>	kg	~0,14
----------------	----	-------	------------------	----	-------

Ventil-Blindstopfen  
Valve blind plug

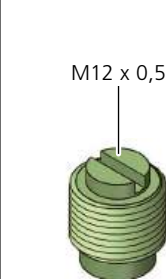

<b>0700102</b>	kg	~0,01
----------------	----	-------

Montage von unten, für Spezialvorrichtungen  
Mounting from bottom side, for special devices

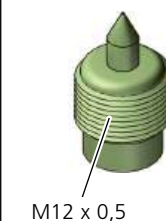

<b>0700200</b>	kg	~0,01
----------------	----	-------

Reduktionstück für Rasterplatten M12/12<sup>f7</sup> auf M6  
Adapter piece for Gridplates from M12/12<sup>f7</sup> to M6

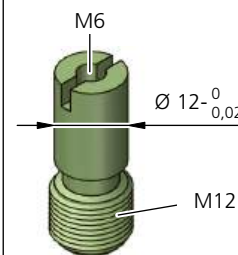

<b>ADAPT6-12</b>	kg	~0,02
------------------	----	-------

### Schnellkupplung mit Bride Quick hose coupling including clip

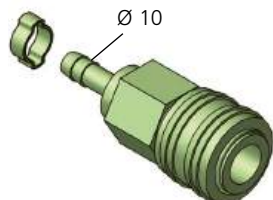

<b>0520000</b>	kg	~0,14
----------------	----	-------

### Schlauchnippel mit Bride Hose nozzle including clip

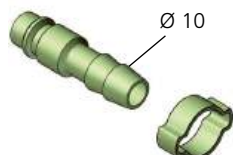

<b>0941010</b>	kg	~0,03
----------------	----	-------

### VHM Profilfräser für Vorrichtungplatten Carbide end mills for plate for dedicated fixtures

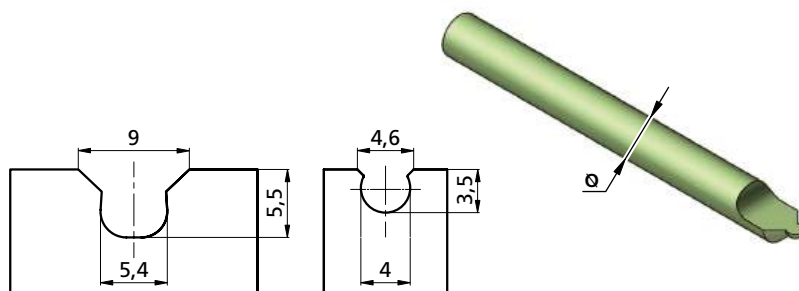

**VFP10065L100 (Ø 6,5 mm)**

Ø = 10
L = 100



**VFP08040L90 (Ø 4 mm)**

Ø = 8
L = 90

**Rotationspumpe auf Speichertank für Arbeiten mit Kühlwasser**

**Aggregat ausgerüstet mit:**

- Vakuumpumpe, Enddruck 20 mbar
- Wasserabscheider mit Sintermetallfilter
- Fahrbarem 40 Liter Behälter als Vakuumspeicher und Wasserreservoir
- 5 Meter Vakuumschlauch
- für 3-Phasenbetrieb wartungsfreie Drehstrommotoren
- für 1-Phasenbetrieb wartungsfreie Motoren mit Anlauf-Kondensatoren.

**für Vakuumaufspannflächen:**

- zusammenhängend, oder auf mehrere einzelne Platten verteilt

**Rotary pumptank assembly Pump assembly for machining with flowing coolant**

**Assembly equipped with:**

- Vacuum pump, pressure limit 20 mbar
- Liquid separator with sintered metall filter
- Pump mounted on a movable 40l (13gal) tank being both, vacuum reservoir and water collector
- 5 m (6.5ft) Vacuum hose
- maintenance-free motors for 3 phase operating
- single phase motors with capacitor starter.

**To cover maximum holding surface:**

- built by plate or plate-assembly, or display over several single plates mounted to various machine-tools

**Technische Daten**  
**Technical data**

**Saugkraft**  
**Suction capacity**

**Spannfläche bis / Surface up to 1,8 m<sup>2</sup>**

3-Phasen / Triple phase 400 V ± 10%, 50 / 60 Hz, 250 / 300 W	6 / 7,2 m <sup>3</sup> /h	<b>UBA306400250</b>
1-Phasen / Single phase 230 V ± 10%, 50 / 60 Hz, 300 / 360 W	6 / 7,2 m <sup>3</sup> /h	<b>UBA106230300</b>
1-Phasen / Single phase 110 V ± 10%, 60 Hz, 250 / 300 W	6 / 7,2 m <sup>3</sup> /h	<b>UBA106110250</b>

**Spannfläche bis / Surface up to 5,0 m<sup>2</sup>**

3-Phasen / Triple phase 400 V ± 10%, 50 / 60 Hz, 550 / 660 W	18 / 21 m <sup>3</sup> /h	<b>UBA318400550</b>
1-Phasen / Single phase 230 V ± 10%, 50 / 60 Hz, 600 / 720 W	18 / 21 m <sup>3</sup> /h	<b>UBA118230600</b>

**Separater Tank / Separate tank**

<b>UBT40</b>
Vol. 40l

**Öl für Vakuumpumpe / Oil for vacuum pump**

<b>UB1-OIL</b>
Vol. 1l



Bedienungsanleitung zu diesem Vakuumpumpen  
Operating instructions for this vacuum pump

➔ Größere Pumpen auf Anfrage  
➔ Larger pumps on demand

# Schaltventil und Druckwächter

## Control unit with pressure sensor switch

trivaCLAMP

Schaltventil  
Control unit

TN100668 kg ~0,096

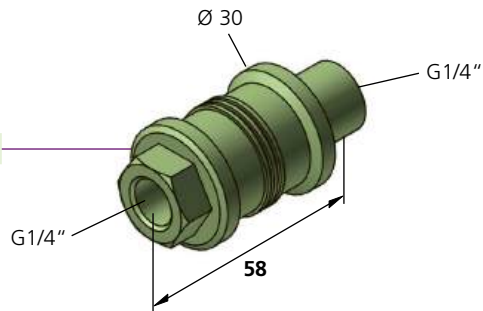

Schaltventil mit Unterdruckanzeige  
Control unit valve with vacuum indicator

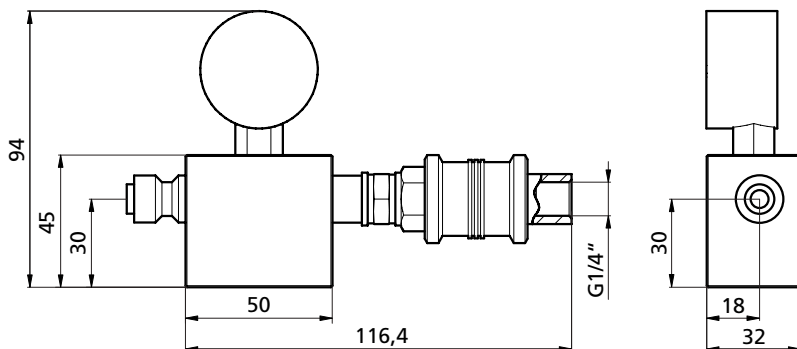

UBS5045

- 1 1x UBS5045-1
- 2 1x 0910000
- 3 3x TN100822
- 4 1x 0920000
- 5 3x TN100086
- 6 1x TN100671
- 7 2x TN100642
- 8 1x TN100925
- 9 1x TN100668
- 10 1x TH120180

kg ~0,74

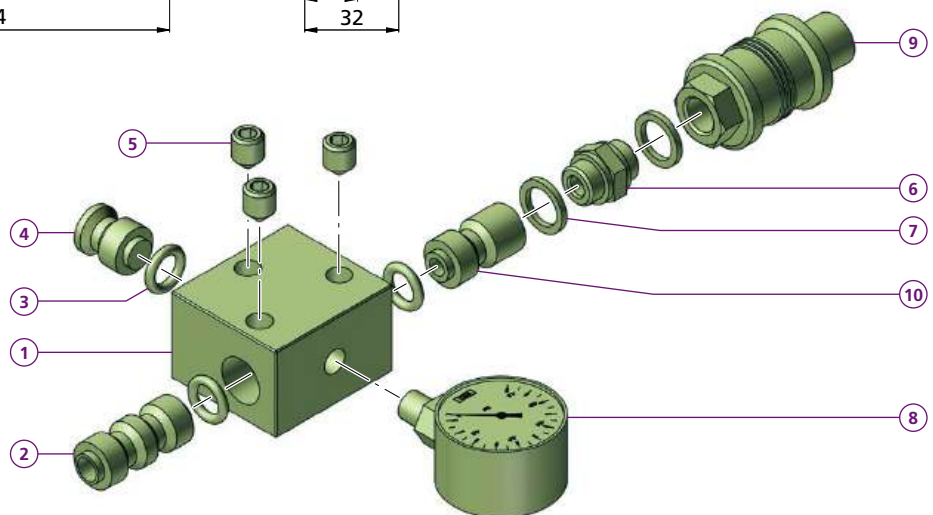

### Druckwächter / Pressure sensor switch

Druck einstellbar; je nach Aufspannung einzustellen.

With adjustable threshold value; to be adjusted according to clamping task.

Anschluss 24-250 V, 50-60 Hz am Ausgang (R) für Elektrokabel zu optischem oder akustischem Warnsignal, oder zum Stillsetzen der Werkzeugmaschine über deren Steuerung, normalerweise mit Funktion M 00 (Programm Stop).

Power supply (24-250 V, 50-60 Hz). Connecting point (R) for wiring to trigger a signal (light or whistle) or to switch the machine tool off via its control system, normally using function M 00 (machine stop), in the event of a drop of vacuum.

Winkelanschluss / Elbow fitting

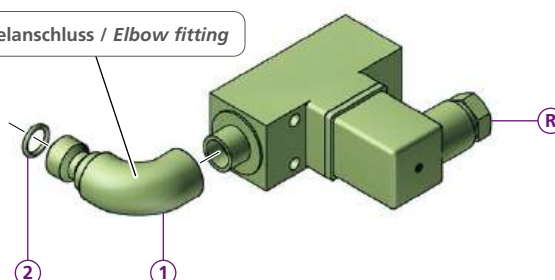

0500205

- 1 1x 0940000
- 2 1x 1111003

➔ Weiteres Zubehör auf Anfrage  
➔ Further accessories on demand

### Vakuumschleuse auf Power-Clamp mit Injektorpumpe für Trocken- und Nasseinsatz

Das modulare Triag Power Clamp Spannsystem kann nun mit Vakuumschleusen bestückt werden. Die Vakuumschleusen können mit oder ohne Zwischenräume gekoppelt werden. Die handliche Injektorpumpe wird mit Pressluft betrieben und kann im Trocken- oder Nasseinsatz verwendet werden.

### Vacuum clamping plates on Power - Clamp with injector pump for dry and wet use

The modular Triag Power Clamp workholding system can now be equipped with vacuum plates. The vacuum plates can be coupled with or without gaps. The handy injector pump is operated with compressed air and can be used in dry and wet applications.

**Maximaler zulässiger Speisedruck: 7 bar**  
**Maximal erreichbares Vakuum: 0,92 bar**

**Maximum allowable supply pressure: 7 bar**  
**Maximum attainable vacuum: 0,92 bar**

Der Normalliter (NI) entspricht dem Volumen, das eine bestimmte Menge (Masse) Gas bei atmosphärischem Druck einnehmen würde. Die Durchflussmenge wird berechnet aus Volumen pro Zeit (NI/s) unter Normalbedingungen (atmosphärischer Druck, 20°C).

The normal litres (NI) is the volume that would take a certain amount (mass) of gas at atmospheric pressure. The flow rate is calculated as volume per time (NI/s) under normal conditions (atmospheric pressure, 20°C).

Typ	Speisedruck	Luftverbrauch	Saugleistung bei 50% Vakuum	Saugleistung bei 90% Vakuum
Type	Feed pressure	Air consumption	Vacuum suction power at 50%	Vacuum suction power at 90%
	bar	NI/s	NI/s	NI/s
UPB1JN	5	2,0	0,6	0,02
	6	2,3	0,5	0,03
UPB2JN	5	4,0	1,2	0,04
	6	4,6	1,0	0,06

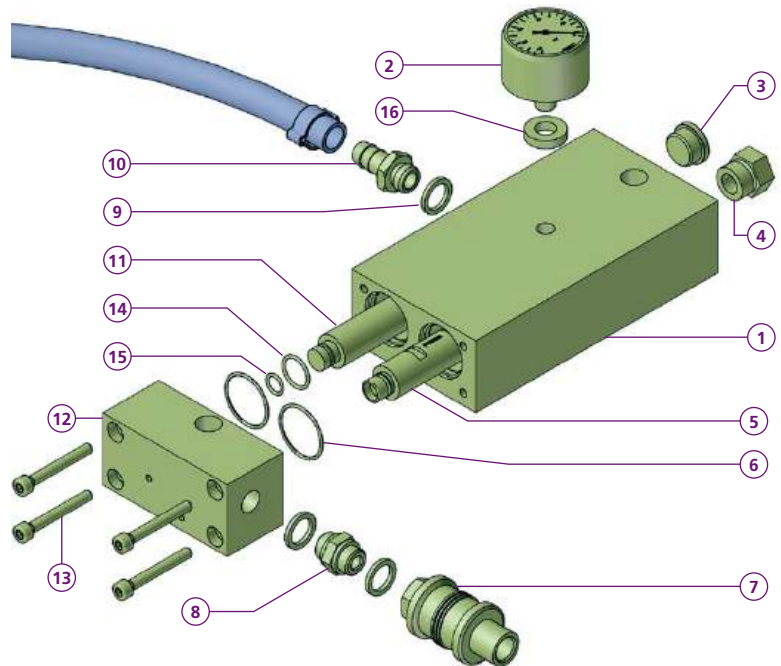
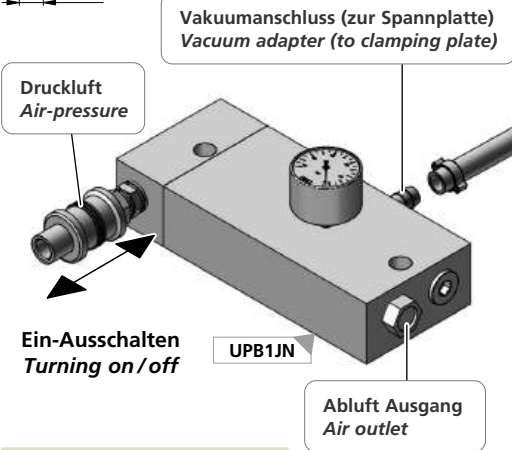
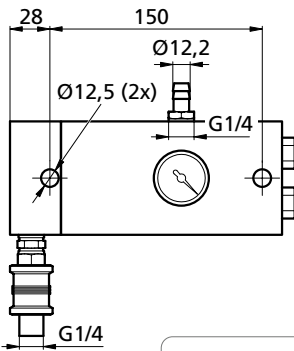
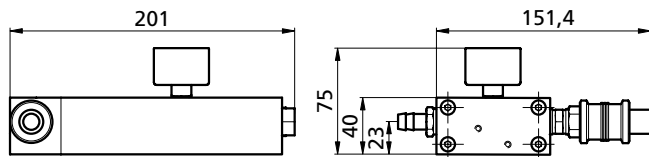

UPB1JN	
1	1x TW090057
2	1x TN100667
3	1x TN100660
4	1x TW100199
5	1x TN100665
6	2x TN100057
7	1x <b>TN100668</b>
8	1x TN100671
9	3x TN100642
10	1x TN100664
11	1x TW090057
12	1x TW90057-02
13	4x TN100666
14	1x TN100691
15	1x TN100163
16	1x TN100942
kg	~1,61

UPB2JN	
1	1x TW090057
2	1x TN100667
4	2x TW100199
5	2x TN100665
6	2x TN100057
7	1x <b>TN100668</b>
8	1x TN100671
9	3x TN100642
10	1x TN100664
12	1x TW90057-02
13	4x TN100666
14	1x TN100691
15	1x TN100163
16	1x TN100942
kg	~1,67

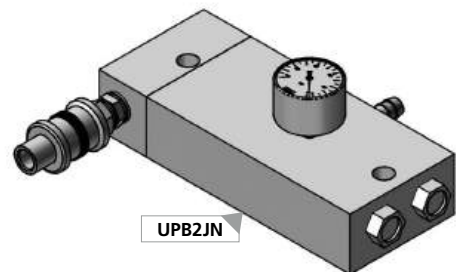

Bestellbeispiel / Ordering example: **UPB1JN**

# Vakuumpumpe mit integriertem Unterdruckausgleich Vacuum pump with integrated vacuum equalisation

trivaCLAMP

UX1AUT

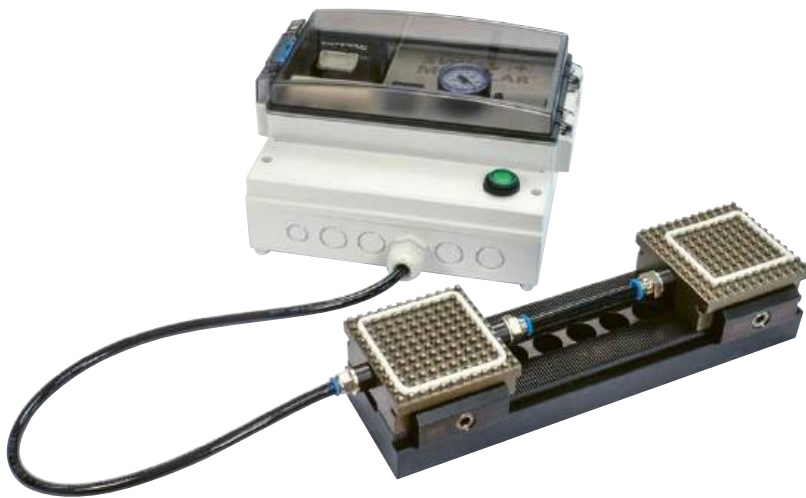

Platz für Lithium-Ionen-Akkumulator  
12V / 4Ah (Makita)  
Space for lithium-ion battery 12 V / 4  
Ah (Makita)

Ladezustands-Anzeige regelmässige  
Sichtprüfung erforderlich!  
State of charge indicator Regular  
visual inspection required!

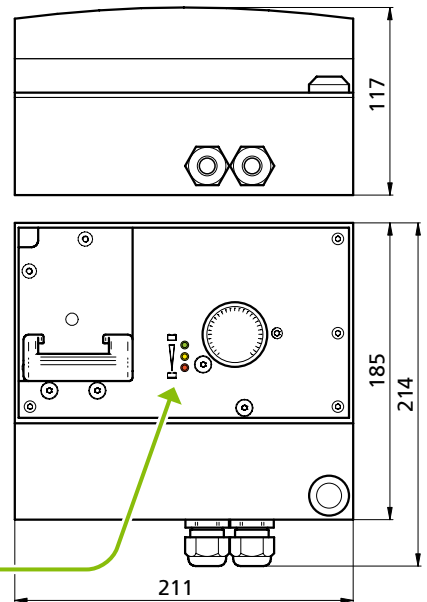
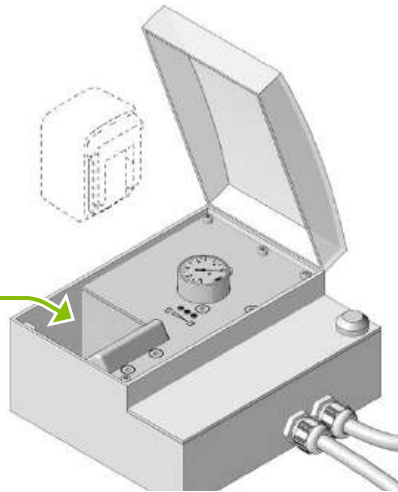



# customCLAMP

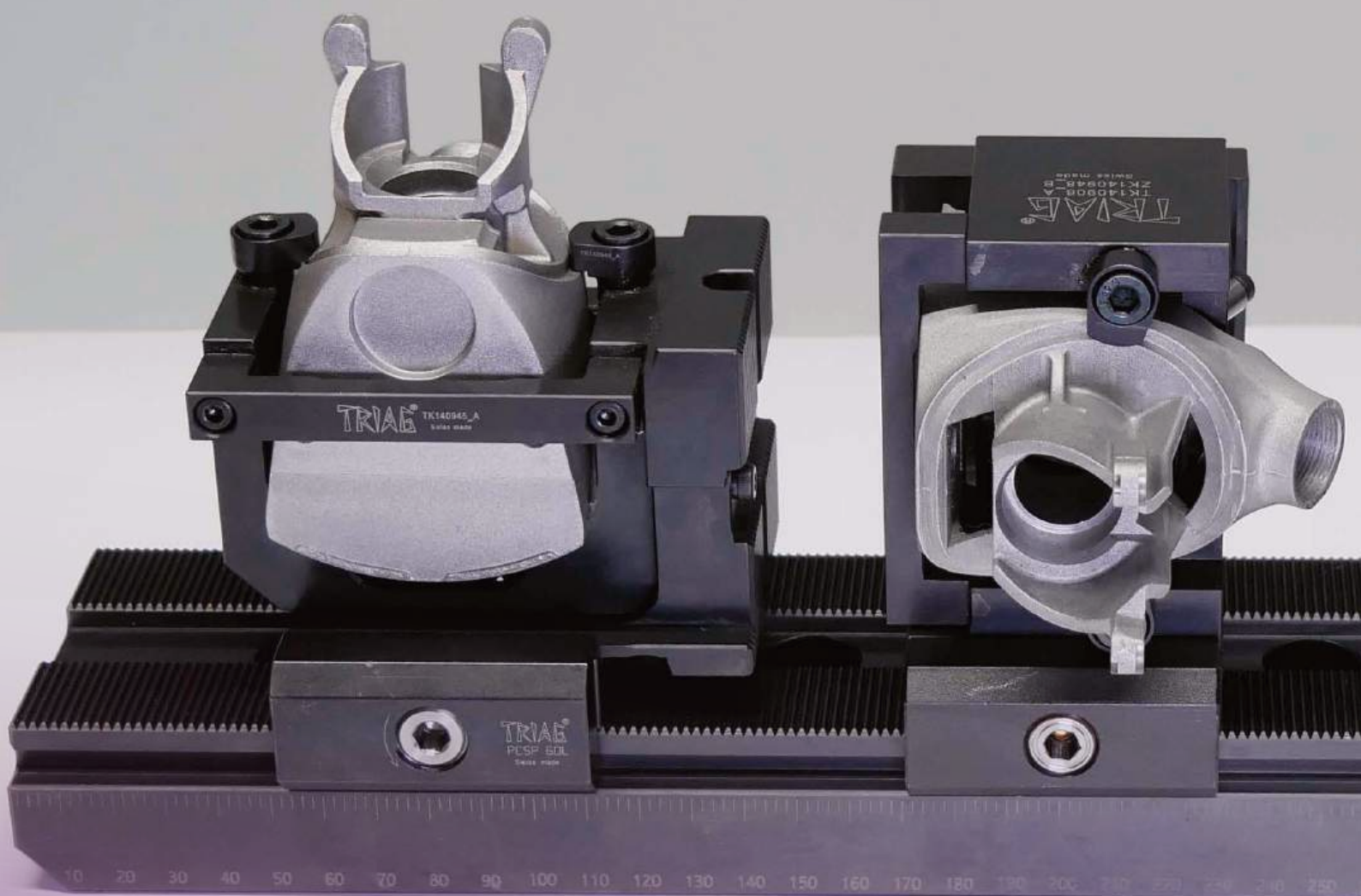

# Fordern Sie uns heraus! Challenge us!



Wir sind Ihr Spezialist für Sondervorrichtungen.  
Nehmen Sie mit uns Kontakt auf.

*We are your specialist for custom made fixtures.  
Feel free to contact us.*



# Komplexe Teile einfach gespannt Complex parts simply clamped



Drei Sonderspannmodule mit powerCLAMP Schnittstelle für komplex geformte Aluminium Druckguss Teile.

*Three customized clamping modules with powerCLAMP interface for complex shaped die cast aluminium pieces.*

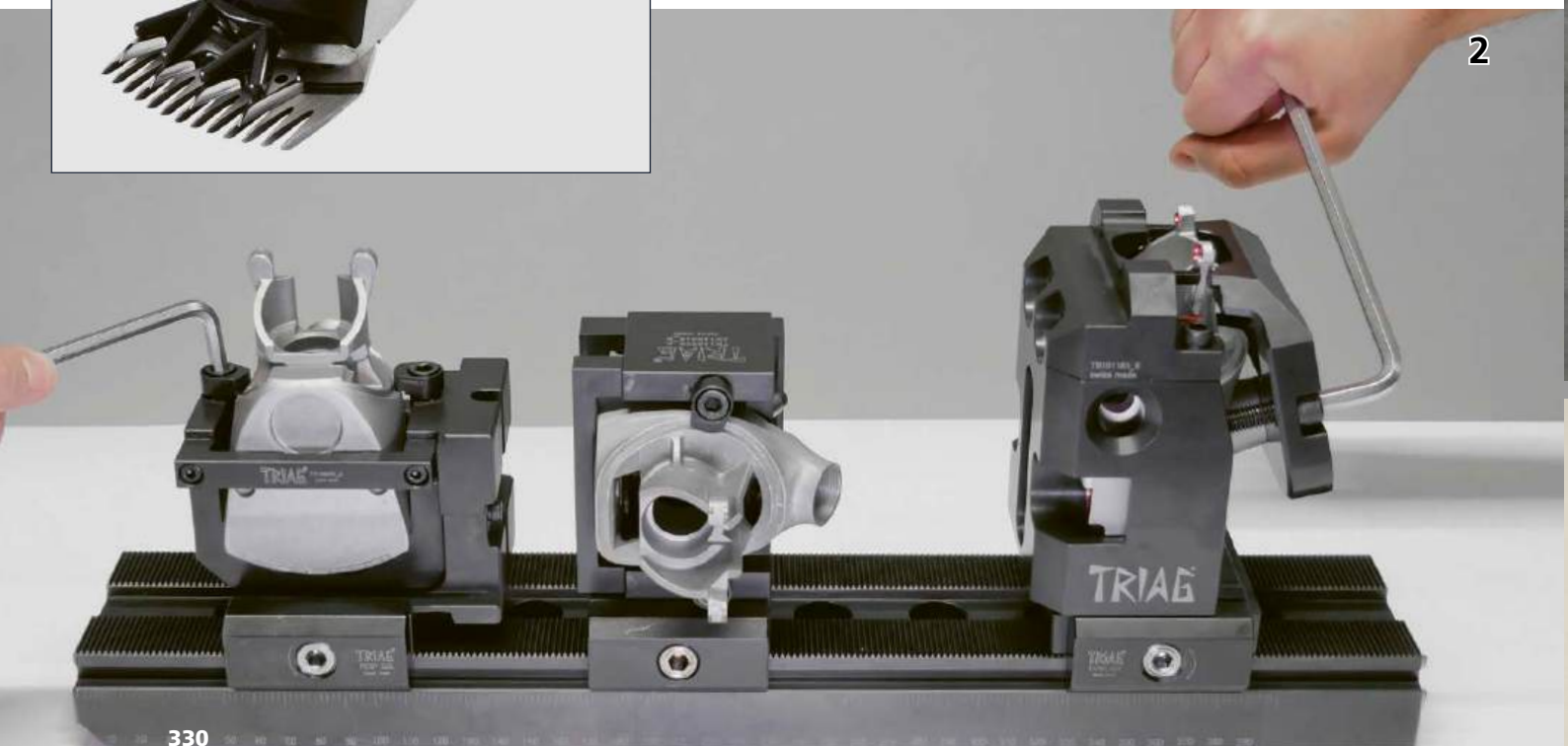

**Anwendungsbeispiele**  
*Examples of application*

**customCLAMP**

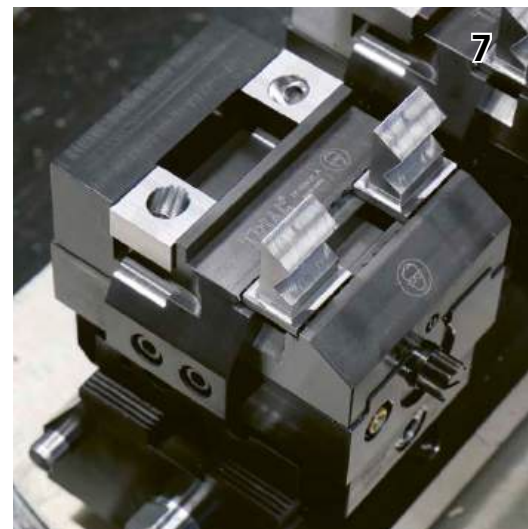
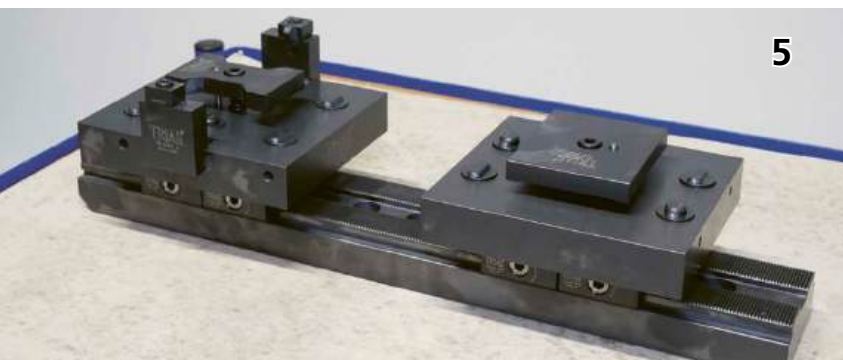
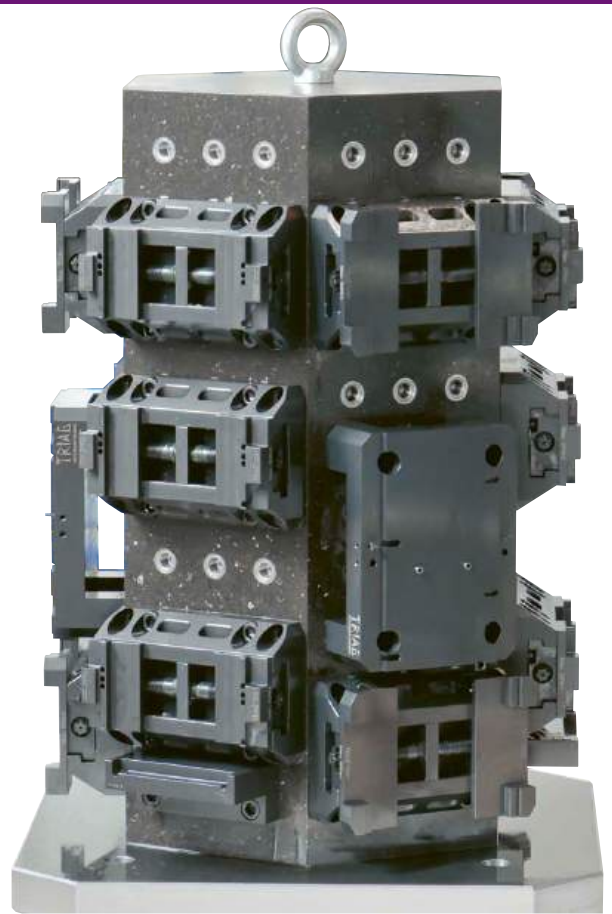





## Zubehör Accessories

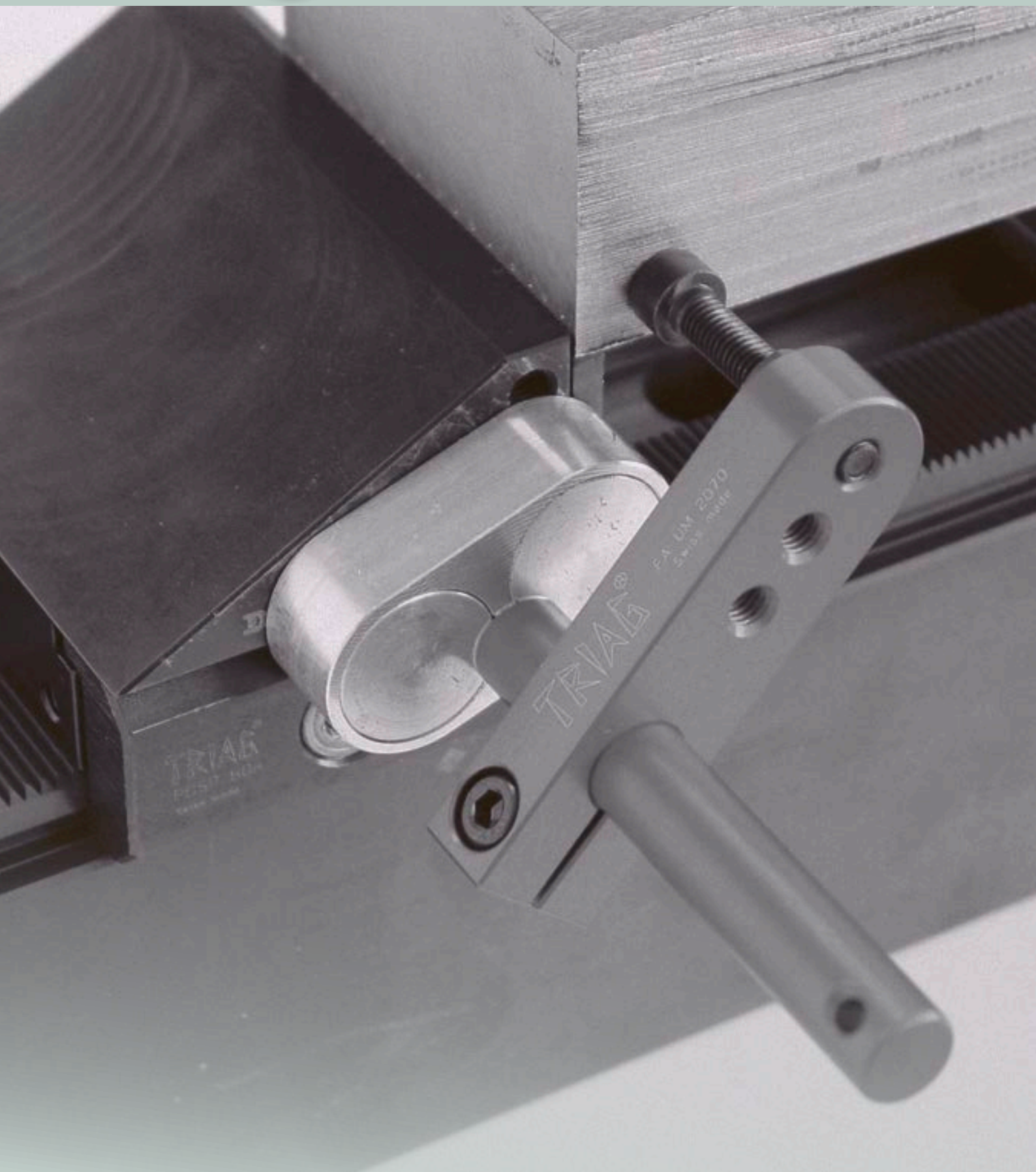

Einstellmasstab | *Measuring device* ..... 335



Magnetanschlag | *Magnetic milling buffer* ..... 336



Fräsanschlag / Hartmetalldruckstück | *Milling buffer / Carbide gripper* ..... 337

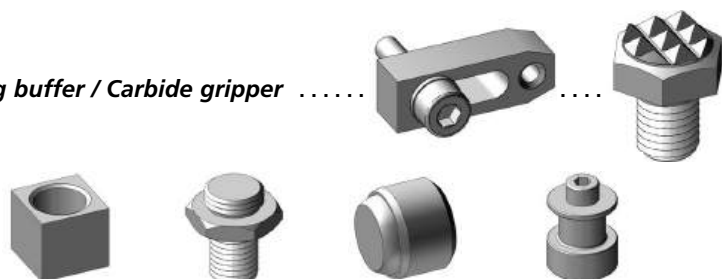

Stopfen / Spanschrauben / Passschrauben / T-Nuten Steine  
*Plug / Clamping screw / Fitting screw / T-slot nuts* ..... 338

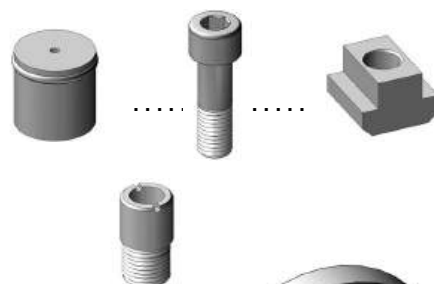

Triag Bitburr / Magnethalter / Pneumatikschrauber Set  
*Magnetic holder / Pneumatic screwdrivers set* ..... 339

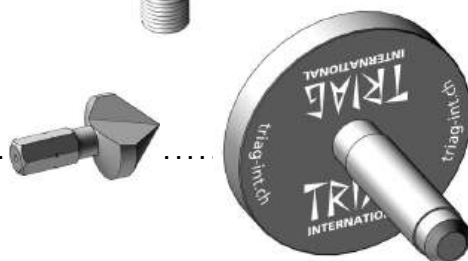

Drehmomentschlüssel / Spanschlüssel / Messingdrahtbürste  
*Torque wrenches / Clamping wrench / Brass wire brush* ..... 340

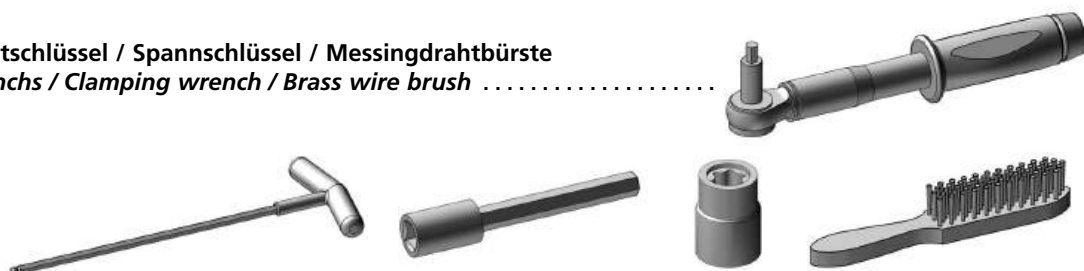

### Masstab mit Magnetleiste

#### Scale with magnet profile

##### PCMAS800ML

- ① 1x PCMAS800ML
  - ② 2x MG1645
  - ③ 2x M3X10ISO4762
  - ④ 1x M6X12BN5128
- kg ~1,0

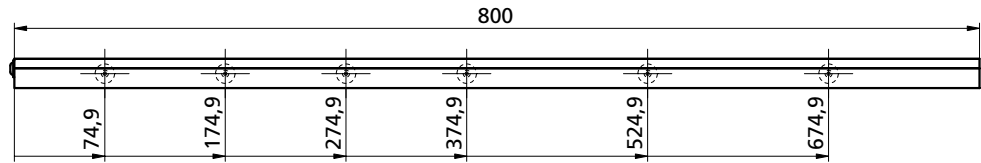

##### PCMAS700ML

- ① 1x PCMAS700ML
  - ② 2x MG1645
  - ③ 2x M3X10ISO4762
  - ④ 1x M6X12BN5128
- kg ~0,88

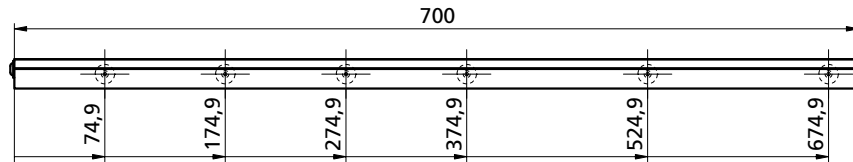

##### PCMAS600ML

- ① 1x PCMAS600ML
  - ② 2x MG1645
  - ③ 2x M3X10ISO4762
  - ④ 1x M6X12BN5128
- kg ~0,75

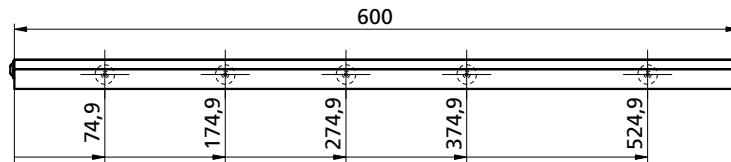

##### PCMAS500ML

- ① 1x PCMAS500ML
  - ② 2x MG1645
  - ③ 2x M3X10ISO4762
  - ④ 1x M6X12BN5128
- kg ~0,63

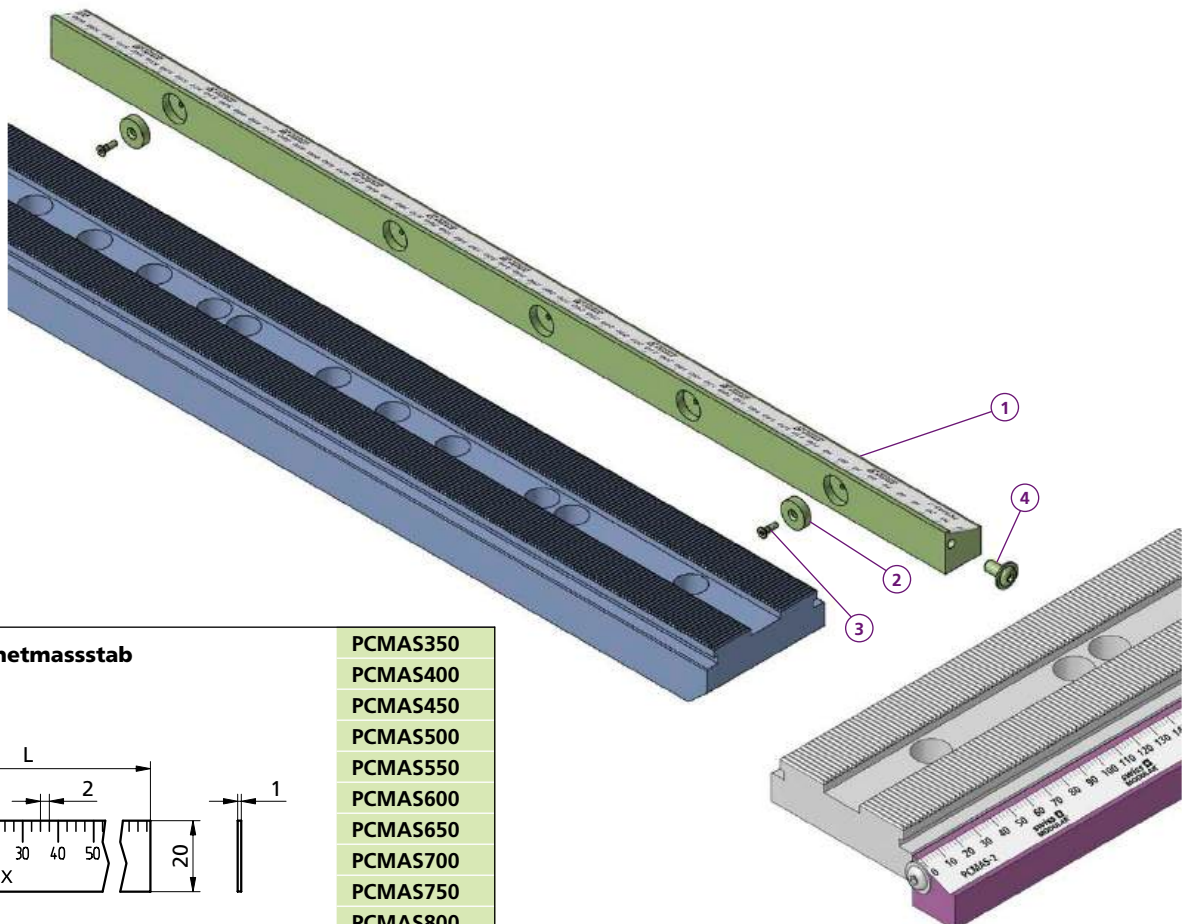
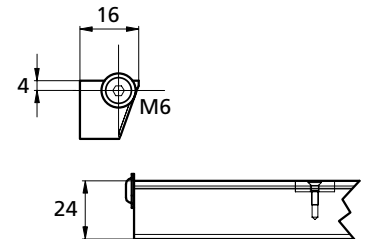
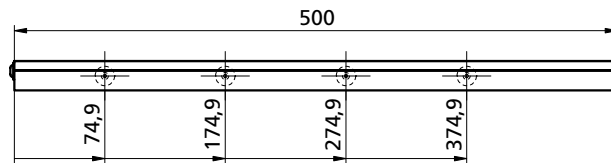

### Alu - Magnetmasstab

#### Alu scale

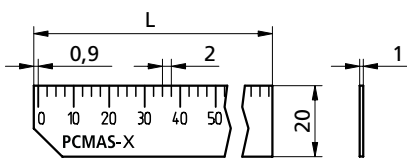

- PCMAS350
- PCMAS400
- PCMAS450
- PCMAS500
- PCMAS550
- PCMAS600
- PCMAS650
- PCMAS700
- PCMAS750
- PCMAS800

Bestellbeispiel / Ordering example : PCMAS800ML

Separat bestellen / Order separately

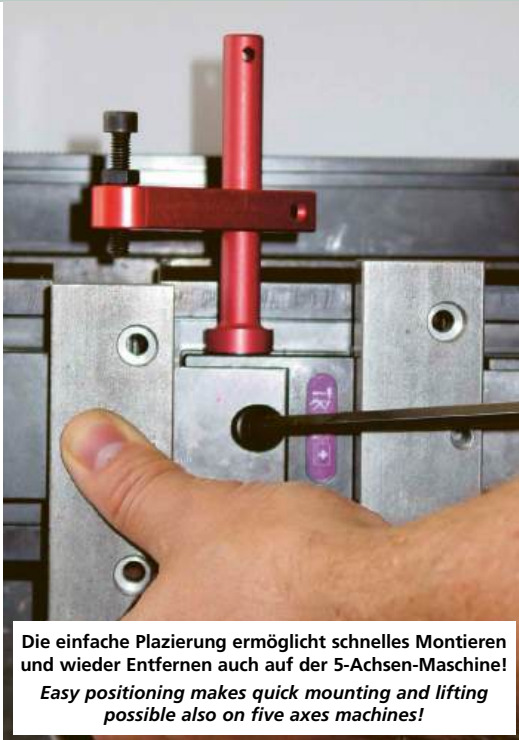

Die einfache Platzierung ermöglicht schnelles Montieren und wieder Entfernen auch auf der 5-Achsen-Maschine!  
Easy positioning makes quick mounting and lifting possible also on five axes machines!

**Die 3 Sicherheitsstufen:**

Durch seine rote Farbe ist der Anschlag besser sichtbar, was das Risiko vermindert, dass er in der Maschine vergessen wird.

Die Bohrung dient zum Befestigen einer Schnur am Handgelenk oder ausserhalb der Maschine.

Dank dem Magnet ist der Anschlag auf allen magnetischen Materialien auf minimalem Platz einsetzbar, bei Kollision wird er weggedrückt. Es entstehen so keine teuren Werkzeugbrüche oder Maschinendefekte.

**The 3 safety levels:**

Because of its red color, the buffer is better visible. So the risk of forgetting the device in the machine is diminished.

The drilling serves to fasten a cord around the wrist or outside the machine.

Its magnet makes the buffer applicable on all magnetic materials on minimum space, in case of collision it gets pressed away, so there won't be any expensive breaking of tools or machines.

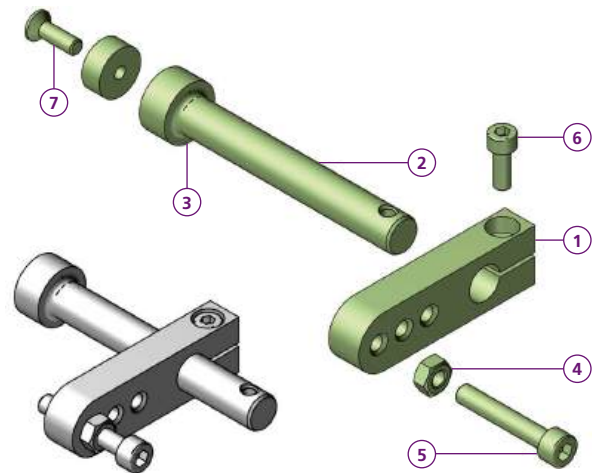
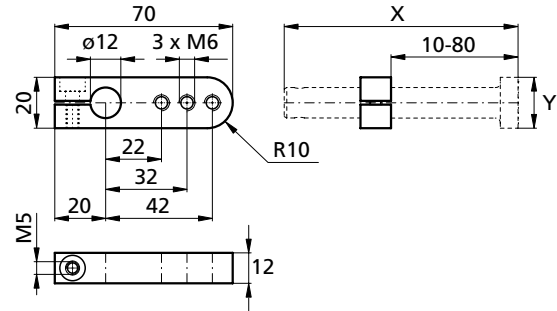

Haltekraft / Holding force	Haltekraft / Holding force
45N = 4,5daN (~4,5 kg)	80N = 8daN (~8 kg)
<b>FAUM2070</b>	<b>FAUM2070S</b>
1 1x FA2070	1 1x FA2070
2 1x FAD2092	2 1x FAD2092S
3 2x MG1645	3 1x MG2570
4 2x M6ISO4032	4 1x M6ISO4032
5 1x M6X35ISO4762	5 1x M6X35ISO4762
6 1x M5X14ISO4762	6 1x M5X14ISO4762
7 1x M3X8ISO10642	7 1x M5X16ISO10642
X = 92	X = 95
Y = ø 20	Y = ø 25
kg ~0,084	kg ~0,1

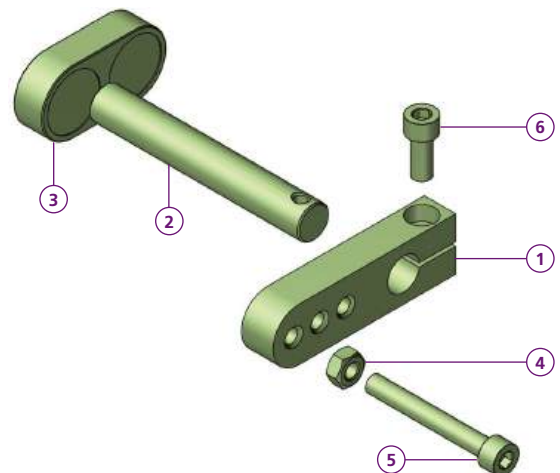
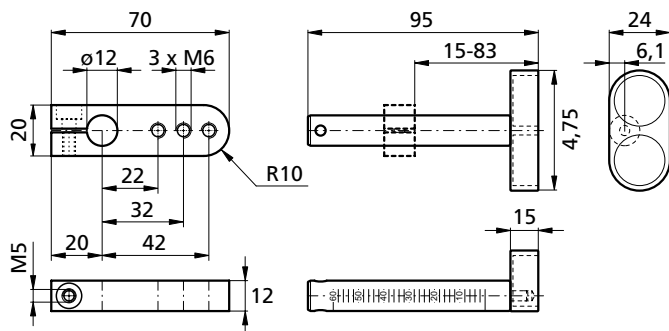

Haltekraft / Holding force
120N = 12daN (~12 kg)
<b>FAUM2070US</b>
1 1x FA2070
2 1x FAD1280
3 1x FUSSUS
4 1x M6ISO4032
5 1x M6X35ISO4762
6 1x M5X14ISO4762
kg ~0,146

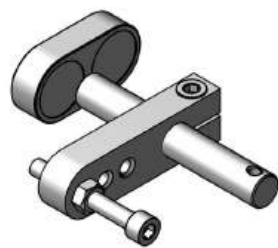

Bestellbeispiel Ordering example : FAUM2070US

**Fräsanschlag / Milling buffer**

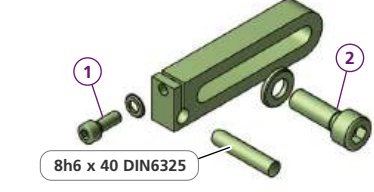
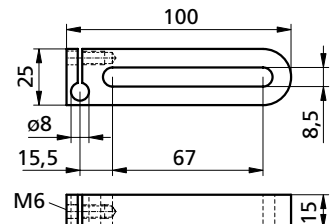
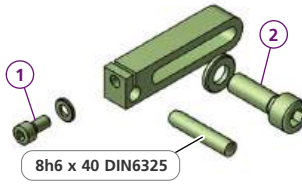
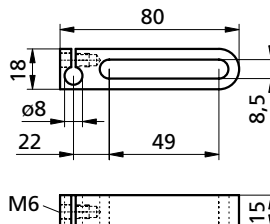
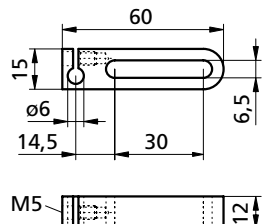
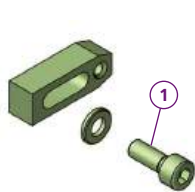
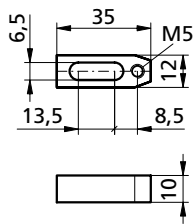

**FA1240**  
 1x M6X18ISO4762  
 1x M5X12ISO4762  
 kg ~0,024

**FA1260**  
 1x M6X20ISO4762  
 1x M5X12ISO4762  
 kg ~0,07

**FA1280**  
 1x M6X12ISO4762  
 1x M8X25ISO4762  
 kg ~0,014

**FA12100**  
 1x M6X16ISO4762  
 1x M8X25ISO4762  
 kg ~0,022

**Distanzbüchse zu Fräsanschlag  
 Spacers for workpiece stop**

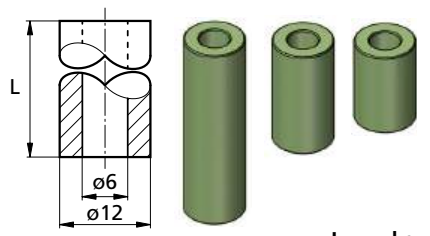
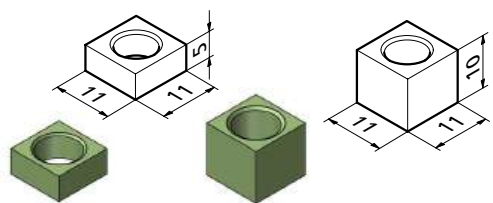

FAD	L	kg
FAD12018	18	~0,012
FAD12023	23	~0,016
FAD12040	40	~0,026

CCD005

CCD010

FAD12018  
 FAD12023  
 FAD12040

**Positionierstift (spreizbar)  
 Locating pin (expandable)**

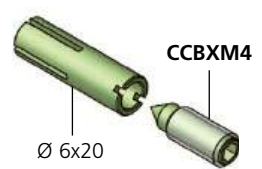

CCBX0802

**Druckstift / Gripping pins**

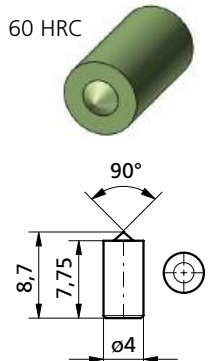

DS0402-90°

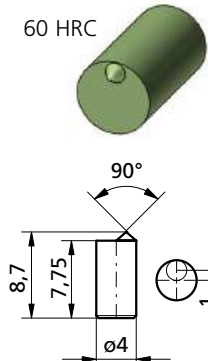

DSE0402-90°

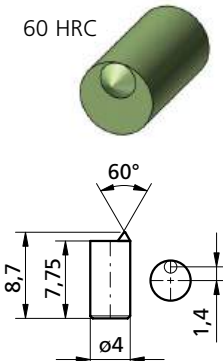

DSE0402-60°

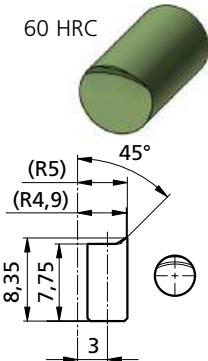

DSE0402-B5

**Einbauanleitung  
 Installation guide**  
 Bohrung vorbereiten  
 Preparation of drill-hole  
 Einkleben mit / Glue with  
 Loctite 641

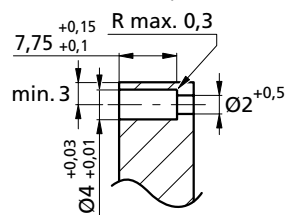

**Hartmetalldruckstück  
 Carbide gripper**

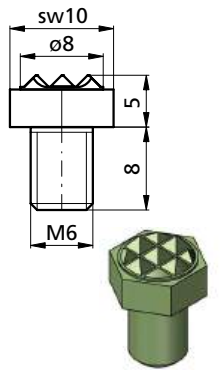

CCHMR

**Prägespannschraube  
 Stamping roll screw**

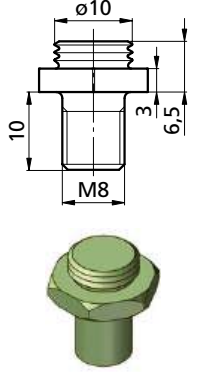

PRG1003M8

**Bohrbild  
 Hole pattern**

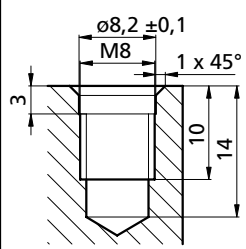

**Kugeldruckstück  
 Gripper**

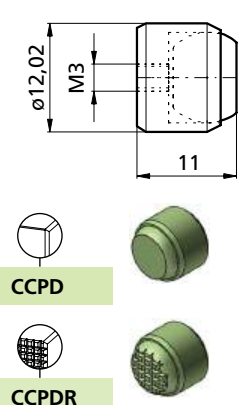

CCPDR

**Ausrichtzapfen für T-Nuten  
 Alignment-pins for t-slots**

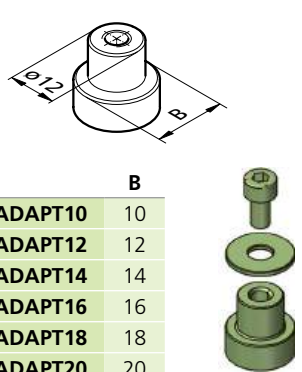

TWADAPT	B
TWADAPT10	10
TWADAPT12	12
TWADAPT14	14
TWADAPT16	16
TWADAPT18	18
TWADAPT20	20
TWADAPT22	22

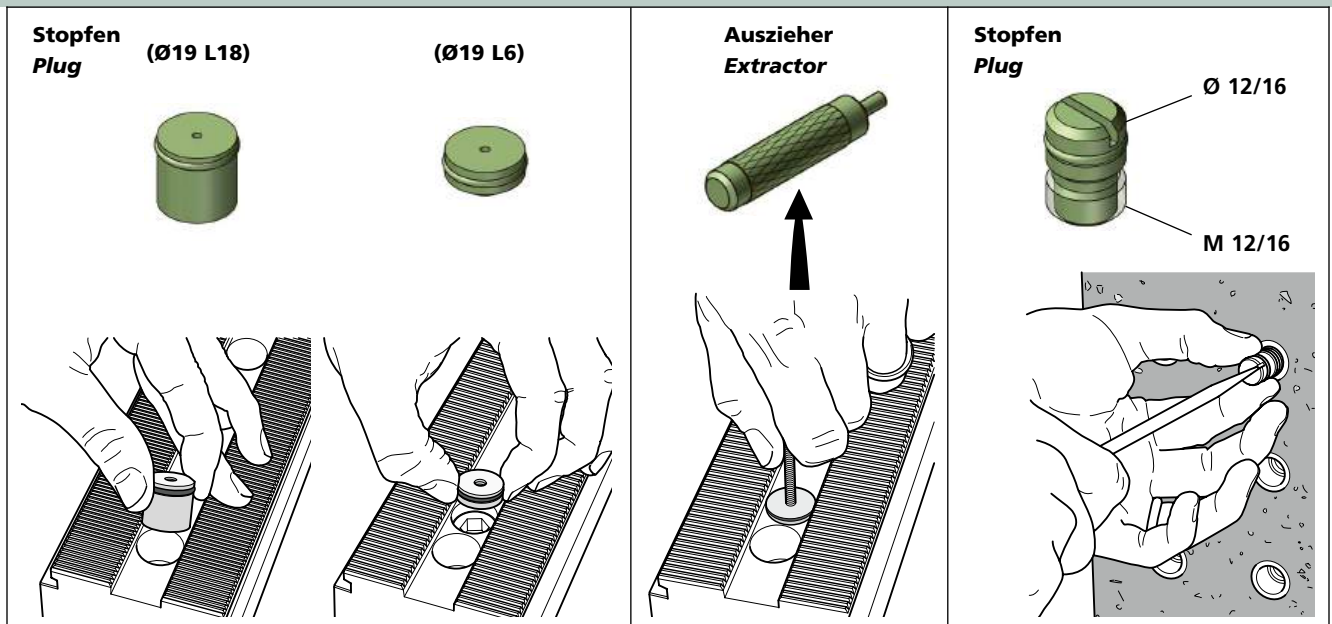

PCPF16L18 PCPF16L6 PCAZM3 CCPF12ALU / CCPF16ALU

**Spannschrauben (Nitriert)**  
**Clamping screw (Nitrided)**

für/for kg

M8x20ISO4762NQ	B60	~0,012
M10x25ISO4762NQ	B80	~0,024

**Passschrauben / Fitting screw**

M5 / M6 / M12 / M16

**Reduktionshülsen für Rasterplatte**  
**Reduction sleeve for grid plate**

RD18M1612M12 RD16M1612M12 RD16M12

	D	G	L	B	K	sw	Nm	kg
MS50	5 f7	M5	17	9	5	4	4,5	~0,004
MS60	6 f7	M6	17	9	6	5	8	~0,006
TWPAS1227	12g7	M12	27	14	12	10	60	~0,038
TWPAS1232	12g7	M12	32	19	12	10	60	~0,042
TWPAS1240	12g7	M12	40	20	12	10	60	~0,048
TWPAS1250	12g7	M12	50	30	12	10	60	~0,058
TWPAS16055	16 f7	M16	55	30	15,8	14	150	~0,120

**T-Nuten Steine / T-slot nuts**

d	α	kg
SM1135 M06X08	~0,012	
SM1135 M06X10	~0,012	
SM1135 M08X10	~0,012	
SM1135 M08X12	~0,022	
SM1135 M08X14	~0,04	
SM1135 M10X12	~0,02	
SM1135 M10X14	~0,038	
SM1135 M12X14	~0,045	
SM1135 M12X16	~0,045	
SM1135 M12X18	~0,078	
SM1135 M12X20	~0,13	
SM1135 M14X16	~0,188	
SM1135 M14X18	~0,188	
SM1135 M16X18	~0,068	
SM1135 M16X20	~0,11	
SM1135 M18X20	~0,11	
SM1135 M18X22	~0,15	
SM1135 M18X22	~0,15	
SM1135 M20X22	~0,15	
SM1135 M20X24	~0,23	
SM1135 M24X28	~0,31	

**Bohrbüchsen**  
**Position case**

	L	D	d
CCBUE121812	12	18,0	12,0
CCBUE1218512	12	18,5	12,0
CCBUE121912	12	19,0	12,0
CCBUE162616	16	26,0	16,0

**Nutensteine, flach**  
**Low slot tenons**

Einsatzgehärtet, brüniert, geschliffen  
Case-hardened, blackened, ground

	b	H	L	d1	d2	t	inkl. Schrauben incl. screws	kg
SM1136- 12	8	20	5,5	10	5,3		M5x12	~0,019
SM1136- 14							M6x16	~0,021
SM1136- 16							M6x16	~0,026
SM1136- 18	10	22	6,6	11	6,3		M6x16	~0,03
SM1136- 20							M6x16	~0,034

**Nutensteine, fest**  
**Fixed slot tenons**

Einsatzgehärtet, brüniert, geschliffen  
Case-hardened, blackened, ground

	H	L	b	Nutenmass slot size	inkl. Schrauben incl. screws	kg
NT2012	10	22	12	20	M6x10	~0,022
NT2014		14	20	M6x10	~0,026	
NT2016		25	16	20	M6x10	~0,028
NT2018	12	18	20	M6x10	~0,03	
NT2022		32	22	20	M6x12	~0,05
NT2024		24	20	M6x12	~0,055	

**Pneumatikschrauber Set**  
**Pneumatic screwdrivers set**

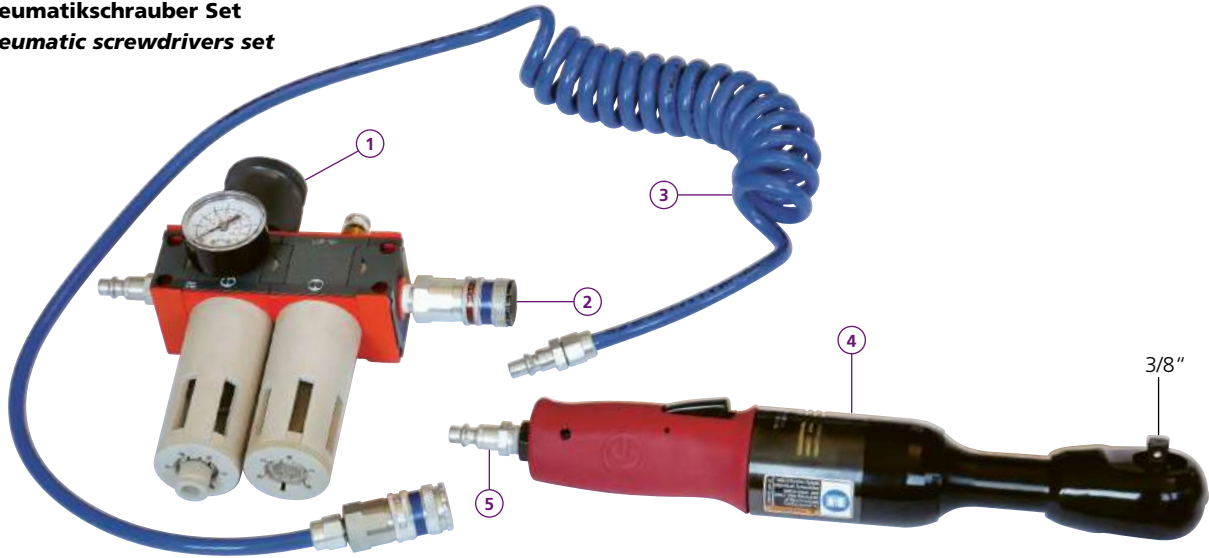

**RP9431SET**

- ① 1x P1H-200-M3QG
  - ② 1x 103002152 (SERIE 300) 1/4"
  - ③ 1x 199589977 (5 x 8 mm, 300, 2 m)
  - ④ 1x RP9431
  - ⑤ 2x 103105152 1/4"
- kg ~1,5

Drehmomenttabelle / Torque table	Druck / Compression (bar)	Nm
	6	50
Schlauchdurchmesser 8 mm	5,5	45
Luftverbrauch 2,5 L Sek	5	40
	4,5	35
Hose diameters 8 mm	4	30
Air consumption 2,5 L sec	3,5	25
	3	20

mit Feder gehalten, nicht magnetisch  
 spring locked, not magnetic



mit Feder gehalten, nicht magnetisch  
 spring locked, not magnetic



siehe Video  
 see video

**Triag Bit**

**Triag Bitburr**

**Luftpistolen Gummiadapter**  
**Air gun rubber adapter**

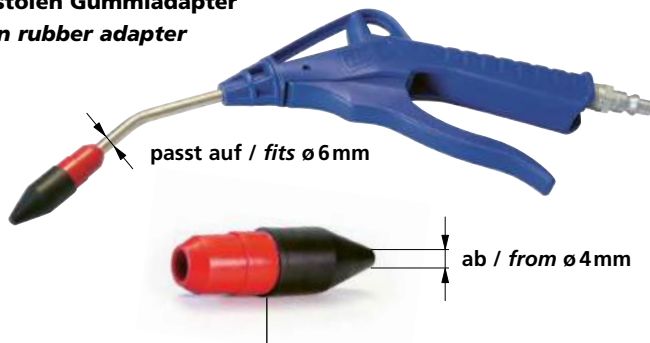

**Einsätze zu Bitburr**  
**Inserts for Bitburr**



TC10

BitF63  $\varnothing 6,3-90^\circ$



BIT-KH

BitF104  $\varnothing 10,4-90^\circ$

**ARA14**

**Magnethalter**  
**Magnetic holder**



**Einsatz für Triva Bit**  
**Insert for Triva Bit**



**Smiley**

**BitT**

**BIT-BF**

BitF165  $\varnothing 16,5-90^\circ$



Bestellbeispiel / Ordering example: **RP9431SET**

**Drehmomentschlüssel**  
*Torque wrench*





**SL3** 20-200 Nm (1/2")

**Steckschlüsseleinsatz**  
*Socket wrench insert*

Torx  Sechskanteinsatz *Hexagon insert* 

NUSS3/8"TX30E14	für / for	MCZ, ZSX, ZSM, ZSB, PCZ
NUSS1/4"4.5MM	4,5 mm	für / for MCZ40L30,
NUSS1/4"5.5MM	5,5 mm	UB5AXSET3, PCZ80L40PRG62

**Sechskantstifteinsatz**  
*Hexagonal socket wrench*

(L) lang  (LK) lang mit Kugelkopf   
(L) long (LK) long with ball head

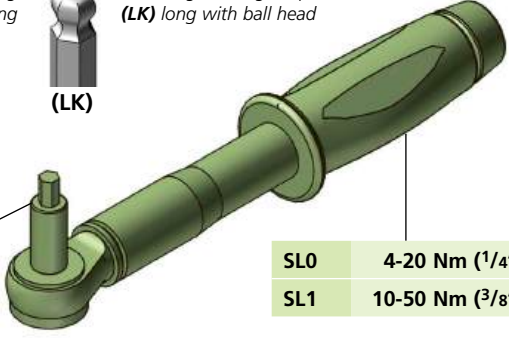

**SL0** 4-20 Nm (1/4")  
**SL1** 10-50 Nm (3/8")

NUSS1/4"4MM	4 mm	NUSS3/8"6MM	
NUSS1/4"5MM	5 mm	NUSS3/8"6MML	6 mm
NUSS1/4"6MM	6 mm	NUSS3/8"6MMLK	
NUSS1/4"8MM	8 mm	NUSS3/8"8MM	
		NUSS3/8"8MML	8 mm
		NUSS3/8"8MMLK	
NUSS3/8"5MM		NUSS3/8"10MM	
NUSS3/8"5MML	5 mm	NUSS3/8"10MML	10 mm
NUSS3/8"5MMLK		NUSS3/8"10MMLK	

**Spannschlüssel**  
*Clamping wrench*



02613160	4 mm
02613164	5 mm
02613168	6 mm
02613172	8 mm
02613176	10 mm

**Langer Spannschlüssel**  
*Long clamping wrench*

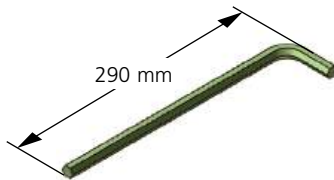

290 mm

ISL10	sw = 10 mm
ISL14	sw = 14 mm

**Sechskantstifteinsatz**  
*Hexagonal socket wrench*



NUSS1/2"8MM	NUSS1/2"14MML
NUSS1/2"10MM	
NUSS1/2"14MM	



AD-BIT-1/4-1/4



AD-BIT-1/4-3/8

**Messingdrahtbürste**  
*Brass wire brush*

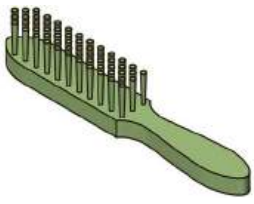

**PCMB4**



**Triag Ei**

**3D Mess-Gelenkstativ**  
*Articulated indicator holders*



Aktionsradius / Operating radius

MGMS08130	130 mm
MGSS08130	130 mm
MGMS08280	280 mm

# Index

- 5AXMCZ100-45-3 136  
5AXMCZ100-45-3H 136  
5AXMCZ100-45-4 134  
5AXMCZ100-45-4H 135  
5AXMCZ100-45-6 136  
5AXMCZ100-45-8 135  
5AXMCZ100-45-12 135  
5AXMCZ100-90-4 134  
5AXZ5X35-3 154  
0130001 324  
0130002 324  
243834.0083300 290  
243834.0103300 290  
243834.0123300 290  
0500205 326  
0520000 324  
0700100 314, 315, 316, 317,  
318, 324  
0700102 314, 315, 316, 317,  
324  
0700200 324  
0802000-SET 322  
0910000 323, 326  
0910001 314, 315, 316, 317,  
318, 323  
0910080 323  
0920000 314, 315, 316, 317,  
318, 319, 323, 326  
0930000 323  
0940200-SET 323  
0940300-SET 323  
0940800 323  
0940800-SET 323  
0941000 321, 323  
0941010 324  
1110100 314, 315, 316, 317,  
321, 324  
1110100S 324  
1110100SP 324  
1111003 314, 315, 316, 317,  
318, 319, 323, 326  
1120100 314, 315, 316, 317,  
318, 319, 321, 324  
1120100M 324  
1130000 324  
02613160 340  
02613164 340  
02613168 340  
02613172 340  
02613176 340  
10100024 323
- A**  
AA5X115-50 228  
AA5X125-50 229  
AA5X125-50VB 231  
AA5X150-50 230  
AAND115-50 228  
AAND125-50 229  
AAND150-50 230  
AC1505520W 233  
AC1505540W 233  
ACB4050400 222  
ACB4050450 222  
ACB4050500 222  
ACB4050550 222  
ACB4050600 222  
ACB4050650 222  
ACB4050700 222  
ACB4050750 222  
ACB4050800 222  
ACBS1646 233
- ACD005 223, 224, 225, 227  
ACES6540 232  
ACES10040H25W 232  
ACES10240H07 232  
ACGGB103048 227, 231  
ACPB103048 227, 231  
ACU21124 232  
ACU36124 232  
ACU41124 232  
ACU46124 232  
ACUH21-124 233  
ACWB103048 227, 231  
ACZ56540 232  
ADAPT6-12 317, 324  
AD-BIT-1/4-1/4 340  
AD-BIT-1/4-3/8 340  
ARA14 339  
AS1F150N50-80 226  
AS1R150N50-80 226  
AS2F115N50-80 223  
AS2F125N50-80 224  
AS2F150N50-80 225  
AS2R115N50-80 223  
AS2R125N50-80 224  
AS2R150N50-80 225  
AS2X125L50-105 227  
AS25X115N50-80 223  
AS25X125L50-105 227  
AS25X125N50-80 224  
AS25X150N50-80 225  
AS35 47, 146  
AS60 47, 146  
AS80 47, 146
- B**  
B01 182, 183, 184, 185  
B02 182, 183, 184, 185  
B03 182, 183, 184, 185  
B04 182, 183, 184, 185  
B05 182, 183, 184, 185  
B05R 182, 183, 184, 185  
B07 178, 179, 180  
B08 178, 179, 180  
B09 178, 179, 180  
B09+2 178, 179, 180  
B09+5 178, 179, 180  
B13 61, 71, 181  
B14 61, 71, 181  
B15 61, 71, 181  
B16 61, 71, 181  
B20 60, 186  
B21 60, 186  
B22 60, 186  
B26 62, 187  
B27 62, 187  
B28 62, 187  
B30 197  
B31 197  
B32 197  
B33 197  
B36 190  
B37 190  
B38 190  
B45 63, 72  
B46 63, 72  
B47 63, 72  
B47HM 63, 72  
B51 198, 201  
B52 198, 201  
B53 198, 201  
B54 198, 201  
B55 198, 201
- B58 64, 73, 188, 189, 191, 192,  
194, 195  
B60 64, 73, 188, 189, 191, 192,  
194, 195, 338  
B61 64, 73, 188, 189, 191, 192,  
194, 195  
B62 64, 73, 188, 189, 191, 192,  
194, 195  
B62HM 64, 73, 188, 189, 191,  
192, 194, 195  
B65 64, 73, 188, 189, 191, 192,  
194, 195  
B66 64, 73, 188, 189, 191, 192,  
194, 195  
B67 64, 73, 188, 189, 191, 192,  
194, 195  
B68 64, 73, 188, 189, 191, 192,  
194, 195  
B69 64, 73, 188, 192  
B77 64, 73, 188, 189, 191, 192,  
194, 195  
B78 198, 201  
B79F 64, 73, 188, 189, 191,  
192, 194, 195  
B79R 64, 73, 188, 189, 191,  
192, 194, 195  
B80 65, 66, 67, 223, 224, 225,  
226, 226  
B80N 65, 66, 67, 223, 224,  
225, 226  
B81 65, 66, 67, 223, 224, 225,  
226  
B82 65, 66, 67, 223, 224, 225,  
226  
B82HM 65, 66, 67, 223, 224,  
225, 226  
B82L33 65, 66, 67, 223, 224,  
225, 226  
B83 65, 66, 67, 223, 224, 225,  
226  
B84 65, 66, 67, 223, 224, 225,  
226  
B89F 65, 66, 67, 223, 224, 225,  
226  
B89R 65, 66, 67, 223, 224, 225,  
226  
B90 68  
B90F78 69  
B90R78 69  
B90W78 69  
B91 68  
B92 68  
B93 68  
B94 68  
B95 70, 193  
B96 70, 193  
B97 70, 193  
B98 70, 193  
B99 70, 193  
B105 77, 79, 80, 81, 85, 200,  
227  
B105-15 85  
B105H20 82  
B105P 85  
B106 85  
B106H20 82  
B106P 85  
B107 85  
B107H20 82  
B107P 85  
B108 85  
B108P 85
- B110 79, 84  
B110H20 82  
B110P 84  
B110P-PRGM8 84  
B111 84  
B111H20 82  
B111P 84  
B112 84  
B112E 84  
B112EP 84  
B112H20 82  
B112HG 84  
B112P 84  
B113 84  
B113P 84  
B115 74, 85, 199  
B115P 85  
B116P 85  
B117P 84  
B120 75, 84  
B120P 80, 84  
B122P 78, 84  
B123P 76, 84  
B130H20P 83  
B131H20P 83  
B132H20P 83  
B140 85  
B140P 85  
B141 85  
B141P 85  
B150 196  
B151 196  
B170 128  
B172 128, 130  
B172-MB 130  
B173-26 129  
B173-45 129  
B173-64 129  
B173-83 129  
B173-102 129  
B173-MB 130  
B173SET 129  
B175-26 128  
B175-45 128  
B175-64 128  
B175-83 128  
B175-102 128  
B175-121 128, 135  
B175-MB 130  
B175SET 128  
B176-80 129  
B190-13 116  
B190-22 116  
B190-31 116  
B190W6-40 117  
B190W10-40 117  
B190W20-40 117  
B190W30-40 117  
B210-62 123, 124  
B212W11-60 123, 124  
B212W20-60 123, 124  
B222 156  
B240UPRG 149  
B242W50-100 149  
B310 105  
B311 105  
B312 105  
B313 105  
BIT-BF 339  
BitF63 339  
BitF104 339  
BitF165 339

# Index

- BIT-KH 339  
BitT 339  
BL-SET 108
- C**  
CC8011 205  
CC8021 205  
CC8025 205  
CC8026 205  
CC8030 205  
CC8040 205  
CC8041 205  
CC8050 205  
CC8050V90 205  
CC8050V120 205  
CC8060 205  
CC8060R 205  
CC8070 205  
CC8210 205  
CC8211 205  
CC8220 205  
CCA21050 204  
CCBO0801 110, 190, 191, 194,  
201, 204, 292  
CCBO0802 186, 187, 188, 189,  
197, 198, 204  
CCBO0803 190, 192, 204  
CCBUE121812 338  
CCBUE121912 338  
CCBUE162616 338  
CCBUE1218512 338  
CCBX0802 204, 337  
CCBXM4 204, 337  
CCBXSK 204  
CCD004 186, 187, 188, 189,  
191, 192, 193, 197, 198,  
201  
CCD005 337  
CCD007 190  
CCD010 337  
CCHMR 51, 64, 65, 66, 67, 68,  
69, 70, 73, 188, 189, 191,  
192, 193, 194, 195, 205,  
223, 224, 225, 226  
CCPD 337  
CCPDR 64, 73, 188, 189, 191,  
192, 194, 195, 337  
CCPF12ALU 338  
CCPF16ALU 338  
CCU15026 204  
CCU15027 204  
CCU15080 204  
CCU15081 204  
CCU15082 204  
CCU15083 204  
CCU20026 204  
CCU20027 204  
CCU20080 204  
CCU20081 204  
CCU20082 204  
CCU20083 204  
CCU25026 204  
CCU25027 204  
CCU25080 204  
CCU25081 204  
CCU25082 204  
CCU25083 204  
CCU27580 204  
CCU27581 204  
CCU27582 204  
CCU27583 204  
CCU30026 204
- CCU30027 204  
CCU30039 204  
CCU30080 204  
CCU30081 204  
CCU32526 204  
CCU32527 204  
CCU35039 204  
CCU35080 204  
CCU40039 204  
CCU40080 204  
CCU45039 204  
CCU45080 204
- D**  
DS0402-90° 337  
DSE0402-60° 205, 337  
DSE0402-90° 337  
DSE0402-BS 337
- E**  
ER-033400 300  
ER-033402 299  
ER-033800 299, 300  
ER-036800 300  
ER-036802 299  
ER-038000 299, 300  
ER-039200 299, 300  
ER-039201 299, 300  
EROWA ITS-Palette 119  
EROWA MTS 297
- F**  
FA1240 337  
FA1260 337  
FA1280 337  
FA12100 337  
FAD12018 337  
FAD12023 337  
FAD12040 337  
FAUM2070 336  
FAUM2070S 336  
FAUM2070US 336  
FED0318 71  
FED0418 60, 62, 186, 187, 197  
FED0618 63, 64, 65, 66, 67, 68,  
69, 70, 72, 73, 110, 188,  
189, 190, 191, 192, 193,  
194, 195, 197, 198, 201,  
223, 224, 225, 226, 227,  
228, 229, 230, 231  
FED02813 182, 183, 184, 185  
FED03018 61, 178, 179, 180,  
181
- G**  
GEWST6L14 196  
GPL30040 273  
GPL40040 273  
GPL40040R50 273  
GPL45040 273  
GPL50040 273  
GPL50040R50 273  
GPL63040 273  
GPL63040R50 273  
GPL80040 273  
GPL50040040 273
- I**  
ISL10 102, 340  
ISL14 340
- M**  
M3X6ISO4762 61, 180, 181  
M3X8ISO4762 205, 322  
M3X10ISO4762 61, 180, 181,  
335  
M3X25ISO4762 197, 198, 201  
M4X8ISO4762 159  
M4X10ISO4762 322  
M5X8ISO4762 112, 190  
M5X8ISO7380 157, 158, 159,  
186, 187, 188, 189, 191,  
192, 193, 197, 198, 201  
M5X10DIN6912 182, 183, 184,  
185  
M5X10DIN7991 200  
M5X10ISO4762 60, 61, 62, 63,  
64, 65, 66, 67, 68, 69, 70,  
71, 72, 73, 74, 75, 76, 77,  
78, 79, 81, 82, 83, 90, 91  
M5X10ISO7380-1 223, 224,  
225, 226, 227, 228, 229,  
230, 231  
M5X12ISO4762 178, 179, 180,  
205, 337  
M5X12ISO7380 186, 187, 188,  
189, 190, 191, 192, 193,  
197, 198, 201, 205  
M5X14ISO4762 60, 62, 63, 64,  
65, 66, 67, 68, 69, 70, 73,  
74, 75, 76, 77, 78, 79, 80,  
81, 82, 83, 182, 183, 184,  
185, 336  
M5X14ISO7380-1 223, 224,  
225, 226, 227  
M5X16ISO4026 73  
M5X16ISO4762 68, 72, 141,  
152, 175, 176, 178  
M5X16ISO7380 190  
M5X18ISO4762 205  
M5X20BN1362 96  
M5X20BN1392 108  
M5X20ISO4762 205  
M5X20ISO7380 231  
M5X22ISO4762 112  
M5X25ISO4762 205  
M5X85ISO4762 109, 110, 112  
M6X8ISO7380 47, 48, 50, 51,  
60, 61, 62, 63, 64, 65, 66,  
67, 68, 69, 70, 71, 72, 73,  
74, 75, 76, 77, 78, 79, 80,  
81, 82, 83, 90, 91, 93, 94,  
95, 96, 98, 100, 101, 102,  
105, 108, 146, 150, 318,  
319  
M6X10ISO4762 141, 142, 146,  
150  
M6X12BN5128 335  
M6X12ISO4762 43, 322, 337  
M6X14ISO10642 104  
M6X16ISO4762 61, 71, 181,  
337  
M6X16ISO7380 126  
M6X18ISO4762 160, 322, 337  
M6X20ISO4762 60, 186, 337  
M6X25ISO4762 177, 322  
M6X35ISO4762 157, 317, 336  
M6X40ISO4762 158  
M6X45ISO4762 98, 314, 315,  
316  
M6X60ISO4762 158  
M8X16ISO4762 157, 158  
M8X20ISO4762 62, 63, 64, 72,  
73, 186, 187, 188, 189,  
190, 191, 192, 194, 195,  
197, 198, 199, 201, 233  
M8x20ISO4762NQ 338  
M8X22DIN7991 175, 176  
M8X25ISO4762 46, 200, 202,  
203, 337  
M8X28ISO4762 74, 75, 76,  
78, 80  
M8X30ISO4762 76, 77, 79, 81,  
188, 192, 199, 200, 203,  
227  
M8X35ISO4762 82, 83, 190,  
191, 194, 201  
M8X50ISO4762 98  
M8X55ISO4762 98, 192  
M10X12ISO4027 314, 315, 316,  
317, 318, 323  
M10X22ISO4762 108  
M10X25ISO4762 65, 66, 67,  
68, 69, 70, 193, 223, 224,  
225, 226  
M10x25ISO4762NQ 338  
M10X30ISO4762 96  
M12X20ISO4762 119  
M12X25DIN7984 274  
M12X30DIN7984 232  
M12X30ISO4762 228, 229, 230,  
231  
M12X35ISO4762 118, 119, 193  
M12X40ISO4762 46, 50  
M12X45ISO4762 43, 46  
M12X50ISO4762 228, 229, 230,  
231  
M16X45ISO4762 223, 224, 225,  
227, 228, 229, 230, 231  
M16X55ISO4762 227, 231  
M16X65ISO4762 228, 229, 230  
M16X70ISO4762 223, 224, 225,  
226, 228, 229, 230  
MA241050R50-4 267  
MA241050R50-8 267  
MA241055R50-4 267  
MA241055R50-8 267  
MA241060R50-4 267  
MA241060R50-8 267  
MA241065R50-4 267  
MA241065R50-8 267  
MA301265R50-8-2 268  
MA301270R50-8-2 268  
MA301275R50-8-2 268  
MABD501550 274  
MABD502050 274  
MABD502550 274  
MABD503050 274  
MAND38-14PRG 176  
MAND38-14PRG6 176  
MAND58-14PRG 141, 152, 154,  
175  
MAND58-14PRG6 175  
MANF38-14F25 176  
MANF38-14RF 176  
MANF38-14W25 176  
MANF58-14F25 176  
MANF58-14RF 176  
MANF58-14W25 154, 176  
MCD004 61, 180, 181  
MCU11037 61, 180, 181, 204  
MCU15037 61, 180, 181, 204  
MCU18037 61, 180, 181, 204  
MCU20037 61, 180, 181, 204  
MCU22537 61, 180, 181, 204  
MCZ40L30 115, 117

# Index

- MCZ40L30E 117  
MCZ40L30PRG13 116  
MCZ40L30PRG22 116  
MCZ40L30PRG31 116  
MCZ40L30W6 116  
MCZ40L30W10 116  
MCZ40L30W20 116  
MCZ40L30W30 116  
MCZ80L32PRG62 123  
MCZ100L50 126, 127, 133,  
134, 135  
MGMS08130 340  
MGMS08280 340  
MGSS081040130 340  
MK200970R50 251  
MK300950R50 251  
MK300955R50 251  
MK300960R50 251  
MK300965R50 251  
MK300970R50 251  
MK300975R50 251  
MK301850R50 253  
MK301855R50 253  
MK301860R50 253  
MK301865R50 253  
MK301870R50 253  
MK301875R50 253  
MK321075R100 254  
MK321080R100 254  
MK321085R100 254  
MK321090R100 254  
MK321095R100 254  
MK321875R100 254  
MK321880R100 254  
MK321885R100 254  
MK321890R100 254  
MK321895R100 254  
MK350865R50 252  
MK350870R50 252  
MK350875R50 252  
MK350880R50 252  
MK350885R50 252  
MK350890R50 252  
MK350895R50 252  
MK351865R50 255  
MK351870R50 255  
MK351875R50 255  
MK351880R50 255  
MK351885R50 255  
MK351890R50 255  
MK351895R50 255  
MK401865R50 256  
MK401870R50 256  
MK401875R50 256  
MK401880R50 256  
MK401885R50 256  
MK401890R50 256  
MK401895R50 256  
MQ161630R50 257  
MQ161635R50 257  
MQ161640R50 257  
MQ161645R50 257  
MQ161650R50 257  
MQ202040R50 258  
MQ202045R50 258  
MQ202050R50 258  
MQ202055R50 258  
MQ202060R50 258  
MQ202065R50 258  
MQ202070R50 258  
MQ242450R50 258  
MQ242455R50 258  
MQ242460R50 258  
MQ242465R50 258  
MQ252560R50 259  
MQ252565R50 259  
MQ252570R50 259  
MQ252575R50 259  
MQ252580R50 259  
MQ303050R50 259  
MQ303055R50 259  
MQ303060R50 259  
MQ303065R50 259  
MQ303070R50 259  
MQ303075R50 259  
MQ353565R50 260  
MQ353570R50 260  
MQ353575R50 260  
MQ353580R50 260  
MQ353585R50 260  
MQ353590R50 260  
MQ353595R50 260  
MQ404065R50 260  
MQ404070R50 260  
MQ404075R50 260  
MQ404080R50 260  
MQ404085R50 260  
MQ404090R50 260  
MQ404095R50 260  
MQ424275R40 269  
MQ424280R40 269  
MQ424285R40 269  
MQ424290R40 269  
MQ424295R40 269  
MR1F30N23-07 178  
MR301550R50-4 261  
MR301555R50-4 261  
MR301560R50-4 261  
MR301565R50-4 261  
MR401245R50 261  
MR401250R50 261  
MR401255R50 261  
MR401260R50 261  
MR402050R50 262  
MR402055R50 262  
MR402060R50 262  
MR402065R50 262  
MR402070R50 262  
MR402075R50 262  
MR502060R50-2 263  
MR502060R50-4 263  
MR502065R50-2 263  
MR502065R50-4 263  
MR502070R50-2 263  
MR502070R50-4 263  
MR502075R50-2 263  
MR502075R50-4 263  
MR502080R50-2 263  
MR502080R50-4 263  
MR502085R50-2 263  
MR502085R50-4 263  
MR502090R50-2 263  
MR502090R50-4 263  
MR502095R50-2 263  
MR502095R50-4 263  
MR602060R50-2 264  
MR602060R50-4 264  
MR602065R50-2 264  
MR602065R50-4 264  
MR602070R50-2 264  
MR602070R50-4 264  
MR602075R50-2 264  
MR602075R50-4 264  
MR602080R50-2 264  
MR602080R50-4 264  
MR602085R50-2 264  
MR602085R50-4 264  
MR602090R50-2 264  
MR602090R50-4 264  
MR602095R50-2 264  
MR602095R50-4 264  
MR633075R40 269  
MR633080R40 269  
MR633090R40 269  
MR633095R40 269  
MR701550R50 265  
MR701555R50 265  
MR701560R50 265  
MR701570R50 265  
MR701575R50 265  
MS1F22N40-07 179  
MS1F24N22-07 180  
MS1F25N25-13 181  
MS1F35L14-152 196  
MS1F35N14-01 182  
MS1F35N22-01 182  
MS1F58L14W251 176  
MS1P58L14PRG15 175  
MS1R24N22-07 180  
MS1R25N25-13 181  
MS1R35L14-152 196  
MS1R35N14-01 182  
MS2F58L14W251 176  
MS2F60N14-01 184  
MS2P58L14PRG15 175  
MS2X35N23-01 183  
MS3F85N14-01 185  
MS50 177, 180, 182, 183, 184,  
185, 196, 338  
MS60 102, 181, 338  
MS321960R50 266  
MS321965R50 266  
MS321970R50 266  
MS321975R50 266  
MS321980R50 266  
MS402366R40 266  
MS402366R50 266  
MS402395R40 266  
MS402395R50 266  
MSK15W45 196  
MST-TRI-600 272  
MUB2817-H85 270  
MUB2817-H100 270  
MUB2817-H125 270  
MUB3535H40 270  
MV1F20L35BV1 101, 177
- N**  
NT2012 338  
NT2014 338  
NT2016 338  
NT2018 338  
NT2022 338  
NT2024 338  
NUSS1/2"8MM 340  
NUSS1/2"10MM 340  
NUSS1/2"14MM 340  
NUSS1/2"14MML 340  
NUSS1/4"4.5MM 116, 118,  
119, 122, 340  
NUSS1/4"4MM 340  
NUSS1/4"5.5MM 97, 123, 124,  
126, 127, 141, 142, 144,  
146, 148, 150, 340  
NUSS1/4"5MM 340  
NUSS1/4"6MM 340
- MR602080R50-4 264  
MR602085R50-2 264  
MR602085R50-4 264  
MR602090R50-2 264  
MR602090R50-4 264  
MR602095R50-2 264  
MR602095R50-4 264  
MR633075R40 269  
MR633080R40 269  
MR633090R40 269  
MR633095R40 269  
MR701550R50 265  
MR701555R50 265  
MR701560R50 265  
MR701570R50 265  
MR701575R50 265  
MS1F22N40-07 179  
MS1F24N22-07 180  
MS1F25N25-13 181  
MS1F35L14-152 196  
MS1F35N14-01 182  
MS1F35N22-01 182  
MS1F58L14W251 176  
MS1P58L14PRG15 175  
MS1R24N22-07 180  
MS1R25N25-13 181  
MS1R35L14-152 196  
MS1R35N14-01 182  
MS2F58L14W251 176  
MS2F60N14-01 184  
MS2P58L14PRG15 175  
MS2X35N23-01 183  
MS3F85N14-01 185  
MS50 177, 180, 182, 183, 184,  
185, 196, 338  
MS60 102, 181, 338  
MS321960R50 266  
MS321965R50 266  
MS321970R50 266  
MS321975R50 266  
MS321980R50 266  
MS402366R40 266  
MS402366R50 266  
MS402395R40 266  
MS402395R50 266  
MSK15W45 196  
MST-TRI-600 272  
MUB2817-H85 270  
MUB2817-H100 270  
MUB2817-H125 270  
MUB3535H40 270  
MV1F20L35BV1 101, 177
- NUSS1/4"8MM 340  
Nuss 1/4 - sw 4,5 122  
NUSS3/8"5MM 340  
NUSS3/8"5MML 340  
NUSS3/8"5MMLK 340  
NUSS3/8"6MM 340  
NUSS3/8"6MML 340  
NUSS3/8"6MMLK 340  
NUSS3/8"8MM 340  
NUSS3/8"8MML 340  
NUSS3/8"8MMLK 340  
NUSS3/8"10MM 340  
NUSS3/8"10MML 340  
NUSS3/8"10MMLK 340  
NUSS3/8"TX30E14 126, 127,  
142, 146, 150, 340
- O**  
OP92BUE23 291  
OP92BUE23ID 291  
OPA1ID160 293  
OPA1ID160R50 293  
OPA1ID200 293  
OPA1ID200R50 293  
OPA1IDPCBD178 293  
OPA4Q200 296  
OPA4Q200R50 296  
OPA182H63-RS 293  
OPA2200 294  
OPA2200R50 294  
OPA3200 295  
OPA3200R50 295  
OPANS-8 301  
OPB1ID 293  
OPB4Q200 296  
OPB4Q200R50ID-4 296  
OPB2200R50 294  
OPB2200R50ID-1 294  
OPB2200R50ID-2 294  
OPB3200ID-1 295  
OPB3200R50 295  
OPBM4Q100D184 286, 287  
OPBM4Q100R50 283, 286, 287  
OPBM4Q100R200 286, 287  
OPEGB 292  
OPEGBID 292  
OPM3X80L75 286, 290  
OPM3X100L82 286, 290  
OPM3X125L88 286, 290  
OPM25-15R50H28 286  
OPM25-15RH40 286  
OPMAD 286  
OPMAW 289  
OPMB12M12 283, 289  
OPMB12M12S 289  
OPMB12M12U 289  
OPMB18M12 119, 289, 290  
OPMB18M12S 289, 290  
OPMB18M12U 289, 290  
OPMBL 289  
OPMBL-25 289  
OPPAD 301  
OPPD 301  
OPRV 301  
OPSKU 301  
OPST-NI 301  
OPUB150H44 286, 289
- P**  
PA5X19-49F 86  
PA5X19-49R 86  
PA5X26-49F 86

# Index

- PA5X26-49R 86  
PA5X34-49F 86  
PA5X34-49R 86  
PA5X43-49F 88  
PA5X43-49R 88  
PA5X48-49F 88  
PA5X48-49R 88  
PA5X94-49F 89  
PA5X94-49R 89  
PA5X125-49F 89  
PA5X125-49R 89  
PAND19-49 86  
PAND25-44 87  
PAND26-49 86  
PAND30-34RV12-35 97  
PAND34-49 86  
PAND43-49 88  
PAND48-34 88  
PAND48-34PRF-A1 90  
PAND48-34PRG-A1 90  
PAND48-49 88  
PAND48-49PRF-A1 90  
PAND48-49PRG-A1 90  
PAND48-75 88  
PAND58-34 88  
PAND58-49 88  
PAND60-19 157, 158, 159  
PAND60-20.5UWB 159  
PAND61-34 88  
PAND61-34RV35-80 97  
PAND68-34 88  
PAND78-34 89  
PAND78-34UPRG 92, 146  
PAND78-34X50UPRG 92  
PAND78-49 89  
PAND78-49UPRG 92  
PAND94-34 89  
PAND94-34PRF-A1 90  
PAND94-34PRG-A1 90  
PAND94-34PRGV 91  
PAND94-44 87  
PAND94-49 89  
PAND94-49PRF-A1 90  
PAND94-49PRG-A1 90, 115, 139  
PAND94-49PRGV 91  
PAND120-49UPRG 92  
PAND125-34PRG-A1 91  
PAND125-49 89  
PAND125-49PRG-A1 90  
PAND150-34PRG-A1 91  
PANF94-34PRGM8 92  
PB2212L/6 202, 203  
PC2280L40PRG62 124  
PC48-34PRG 106  
PC48-49PRG 106  
PC94-34PRG 106  
PC94-49PRG 106  
PC4349 106  
PC4349DS 107  
PC4834 106  
PC4834DS 107  
PC4834RF 106  
PC4849 106  
PC4849DS 107  
PC4849RF 106  
PC9434-25PRGM8 106  
PC9434DS 107  
PC9434NVB 111  
PC9434RF 106  
PC9434V90-2 107  
PC9434V120 107  
PC9449DS 107  
PC9449NVB 111  
PC9449RF 106  
PC9449V90-2 107  
PC9449V120 107  
PC9460 106  
PC9460R 106  
PC12549 106  
PC12549DS 107  
PC943425W 107  
PC943430W 107  
PC944930W 107  
PC1254930W 107  
PCA2M3 338  
PCB250Q90H35 47  
PCB850SET 46  
PCB900SET 46  
PCB950SET 46  
PCB1000SET 46  
PCB6090 42  
PCB25200 42, 50  
PCB25300 42, 50  
PCB50207W25 52  
PCB50207W27 52  
PCB50320 42  
PCB50320H60 43  
PCB50320H80 44  
PCB50350H80 44  
PCB50400H80 44  
PCB50450H80 44  
PCB50500H80 44  
PCB50550H80 44  
PCB50600H80 44  
PCB50650H80 44  
PCB50700H80 44  
PCB50750H80 44  
PCB100350H60 43  
PCB100400H60 43  
PCB100500H60 43  
PCB100600H60 43  
PCB100650H60 43  
PCB100690H60 43  
PCB100850H60 43  
PCB2550250 42  
PCB2550250-OPM 286  
PCB4050125 42  
PCB4050125H80 44  
PCB4050220W2 42  
PCB4050250KP 46  
PCB4050350 42  
PCB4050400 42  
PCB4050400KP 46  
PCB4050450 42  
PCB4050450KP 46  
PCB4050500 42  
PCB4050500KP 46  
PCB4050550 42  
PCB4050600 42  
PCB4050650 42  
PCB4050650KP 46  
PCB4050700 42  
PCB4050700KP 46  
PCB4050750 42  
PCB4050800 42  
PCBP69SET 46, 244  
PCBR40 43  
PCD005 60, 62, 63, 64, 65, 66, 67, 68, 69, 70, 73, 74, 75, 76, 77, 78, 79, 80, 81, 82, 83, 223, 224, 225, 226, 227  
PCD008 68, 72  
PCFM58 110  
PCFM3322 110  
PCFM5822 110  
PCFX30 109  
PCFX35 109  
PCFX50 109  
PCFX70 109  
PCGL15050 53  
PCGU2028 108  
PCGU2030 47, 61, 71, 93, 146  
PCGU2030LB 108  
PCGU2049 48, 50, 51, 60, 62, 63, 64, 65, 66, 67, 68, 69, 70, 72, 73, 90, 91, 93, 94, 95, 96, 100, 101, 102, 105, 150, 318, 319  
PCGU2049F 104  
PCGU2059 74, 75, 76, 77, 78, 79, 80, 81, 82, 83, 94, 98  
PCL4349N 108  
PCL4834N 108  
PCL9434N 108  
PCL9449N 108  
PCL12549N 108  
PCMAS350 335  
PCMAS400 335  
PCMAS450 335  
PCMAS500 335  
PCMAS500ML 335  
PCMAS550 335  
PCMAS600 335  
PCMAS600ML 335  
PCMAS650 335  
PCMAS700 335  
PCMAS700ML 335  
PCMAS750 335  
PCMAS800 335  
PCMAS800ML 335  
PCMB4 340  
PCMB50300H175 45  
PCMB50400H175 45  
PCMB50500H175 45  
PCMB50600H175 45  
PCMT150-700 53  
PCMT150-750 53  
PCMT150-800 53  
PCMT150-850 53  
PCPF16L6 46, 338  
PCPF16L18 46, 338  
PCS14 47, 48, 50, 51, 60, 61, 62, 63, 64, 65, 66, 67, 68, 69, 70, 71, 72, 73, 74, 75, 76, 77, 78, 79, 80, 81, 82, 83, 90, 91, 93, 94, 95, 96, 98, 100, 101, 102, 104, 105, 126, 146, 150, 318, 319  
PCS14M107SET 126, 127  
PCS16TR140SET 141, 142, 150  
PCS16TR160SET 141, 142, 150  
PCS16TR180SET 141, 142, 150  
PCS16TR200SET 141, 142, 146, 150  
PCSET18220W2-OPM 286  
PCSET18250-OPM 286  
PCSP10B 109, 110, 112  
PCSP10G 109, 110, 112  
PCSP10SET 110  
PCSP30L 47, 61, 93, 146  
PCSP30R 47, 61, 93, 146  
PCSP40L 71  
PCSP40R 71  
PCSP50L 65, 67, 72, 91, 93, 94, 95, 96, 104, 318  
PCSP50LF 68  
PCSP50R 65, 67, 72, 91, 93, 94, 95, 96, 104, 318  
PCSP50RF 68  
PCSP60L 48, 50, 51, 60, 62, 63, 64, 65, 66, 67, 68, 69, 70, 73, 74, 75, 76, 77, 78, 79, 80, 81, 82, 83, 90, 91, 93, 94, 96, 98, 100, 101, 102, 105, 126, 319  
PCSP60LG 150  
PCSP60R 48, 50, 51, 60, 62, 63, 64, 65, 66, 67, 68, 69, 70, 73, 74, 75, 76, 77, 78, 79, 80, 81, 82, 83, 90, 91, 93, 94, 96, 98, 100, 101, 102, 105, 126, 319  
PCSP60RG 150  
PCT30P-153-4 52  
PCT110-250MATS 54  
PCT110-300 53  
PCT110-300MATS 54  
PCT110-350 53  
PCT110-400 53  
PCT110-450 53  
PCT110-500 53  
PCT110-550 53  
PCT110-600 53  
PCT110-650 53  
PCT110-700 53  
PCT155-290-3MATS 54  
PCU10093 112  
PCU14093 112, 232  
PCU20018 112  
PCU20025 112  
PCU20033 112  
PCU20042 112  
PCU20047 112  
PCU20057 112  
PCU20060 112  
PCU20067 112  
PCU20077 112  
PCU20077B10 112  
PCU20077B10-W 112  
PCU20093 112, 232  
PCU20124 112, 232  
PCU24018 112  
PCU24025 112  
PCU24033 112  
PCU24042 112  
PCU24047 112  
PCU24057 112  
PCU24060 112  
PCU24067 112  
PCU24077 112  
PCU24093 112, 232  
PCU24093B10 112  
PCU24093B10-W 112  
PCU24124 112, 232  
PCU29018 112  
PCU29025 112  
PCU29033 112  
PCU29042 112  
PCU29047 112  
PCU29057 112  
PCU29060 112  
PCU29067 112  
PCU29077 112  
PCU29093 112, 232  
PCU29093B10 112

# Index

- PCU29124 112, 232  
PCU31018 112  
PCU31025 112  
PCU31033 112  
PCU31042 112  
PCU31047 112  
PCU31057 112  
PCU31060 112  
PCU31067 112  
PCU31077 112  
PCU31093 112, 232  
PCU31093B10 112  
PCU31124 112, 232  
PCU34018 112  
PCU34025 112  
PCU34033 112  
PCU34042 112  
PCU34047 112  
PCU34077 112  
PCU34093 112, 232  
PCU34093B10 112  
PCU34124 112, 232  
PCU39018 112  
PCU39025 112  
PCU39033 112  
PCU39042 112  
PCU39047 112  
PCU39077 112  
PCU39093 112, 232  
PCU39093B10 112  
PCU39093B10-W 112  
PCU39124 112, 232  
PCU44018 112  
PCU44025 112  
PCU44033 112  
PCU44042 112  
PCU44047 112  
PCU44077 112  
PCU44093 112, 232  
PCU44093B10 112  
PCU44093B10-W 112  
PCU44124 112, 232  
PCU46033 112  
PCU46042 112  
PCU46047 112  
PCU46093 112, 232  
PCU46093B10 112  
PCU46093B10-W 112  
PCU46124 112  
PCU46518 112  
PCU46525 112  
PCU46533 112  
PCU47042 112  
PCU47093 112  
PCUB60-70-130 51  
PCUB60-130 48  
PCUB100-200 48  
PCUB100-300 48  
PCUB115-200-R25 50  
PCUB115-300-R25 50  
PCUD14093 110  
PCUD20093 110  
PCUD24093 110  
PCUD29093 110  
PCUD31093 110  
PCUD34093 110  
PCUD34093TG 110  
PCUD39093 110  
PCUD44093 110  
PCUD46093 110  
PCUD47093 110  
PCUD49093TG 110  
PCUH2594 112  
PCUM1409308 111  
PCUM2009308 111  
PCUM2409308 111  
PCUM2909308 111  
PCUM3109308 111  
PCUM3409308 111  
PCUM3909308 111  
PCUM4409308 111  
PCUM4609308 111  
PCUSR14 200  
PCWB252594 73  
PCWB252594RF 73  
PCWB262694 73  
PCZ80L40PRG62 123  
PCZ100L50 126  
PCZB7021PRF 152  
PCZB7023PRG 152  
PCZB8050UPRG 150, 152  
PCZB8060R34 152  
PCZB8060R40ALU 152  
PCZB10060R50 152  
PCZB10060R50ST 152  
PCZB12060R34 152  
PCZS2439-ID-SET 126, 127  
PCZS2439L 126, 127  
PCZS2439R 126, 127  
PF-SET 85  
PR94-39-50 94  
PR94-39-50SET 94  
PR94-49 94  
PR94-49SET 94, 143  
PR125-49 94  
PR125-49ALU 94  
PR125-49SET 94  
PR125-49SETALU 94  
PR150-49 94  
PR150-49SET 94  
PRG1003M8 129, 152, 337  
PRS50L78ST 96  
PRS70L78ST 96  
PS1F19N49-20 60  
PS1F20L35BV1 101  
PS1F20L35BV1NS 101  
PS1F25N44-13 61  
PS1F26N49-26 62  
PS1F34N49-45 63  
PS1F43N49-60 51, 64  
PS1F43N62-60 64  
PS1F48L34-105 76  
PS1F48L49-105 79  
PS1F48N34-80 65  
PS1F48N49-80 66  
PS1F58N34-80 65  
PS1F68N34-80 65  
PS1F78L34-105 77  
PS1F78L49-105 77  
PS1F78N34-80 67  
PS1F78N49-80 67  
PS1F78N49-90 69  
PS1F94L34-105 81  
PS1F94L49-105 81  
PS1F94N34-80 67  
PS1F94N34-90 68  
PS1F94N49-90 68  
PS1F125L49-105H20 83  
PS1F125N49-95 70  
PS1F-KLD1 100  
PS1F-KLD1NS 100  
PS1P48L34-105 74  
PS1P48L49-105 74  
PS1P94L34-105 75  
PS1P94L49-105 75  
PS1P694L34-105 75  
PS1PF48L34-105 74  
PS1PF48L49-105 74  
PS1PF94L34-105 75  
PS1PF94L49-105 75  
PS1PV48L34-105 76  
PS1PV94L34-105 78  
PS1PV94L49-105 78  
PS1R19N49-20 60  
PS1R25N44-13 61  
PS1R26N49-26 62  
PS1R34N49-45 63  
PS1R43N49-60 64  
PS1R43N62-60 64  
PS1R48L34-105 76, 77  
PS1R48L49-105 79  
PS1R48L49-105H20 82  
PS1R48N34-80 65  
PS1R48N49-80 66  
PS1R48N75-80 66  
PS1R58N34-80 65  
PS1R58N49-80 65  
PS1R68N34-80 65  
PS1R78L34-105 77  
PS1R78L49-105 77  
PS1R78N34-80 67  
PS1R78N49-80 67  
PS1R78N49-90 69  
PS1R94L34-105 81  
PS1R94L49-105 81  
PS1R94L49-105H20 82  
PS1R94N34-80 67  
PS1R94N34-90 68  
PS1R94N49-90 68  
PS1R125L49-105H20 83  
PS1R125N49-95 70  
PS1X50L78ST 96  
PS1X50N62-ER32 99  
PS1X50N70H-ER32-NS 99  
PS1X50N100-ER32 99  
PS1X63N100-ER40 99  
PS1X68N80-W20 99  
PS1X70L78ST 96  
PS1X80L31-VAC 319, 321  
PS1X100-65ER-036345 104  
PS1X150L60-250MAG11 102  
PS1X150L60-VAC 103, 318, 321  
PS2F61N34-45 72  
PS2G94N44-13 71  
PS2R61N34-45 72  
PS2X94N49-60 73  
PS3X80L75BSET 98  
PS3X100L82BSET 98  
PS3X125L87BSET 98  
PS5X19N49-20 60  
PS5X26N49-26 62  
PS5X34N49-45 63  
PS5X43N49-60 64  
PS5X48L34-105 80  
PS5X48L49-105 79  
PS5X48N49-80 66  
PS5X94L49-105 81  
PS5X94N49-90 68  
PS5X125N49-95 70  
PSH1X94L49-310 105  
PT-F61-25X30 93  
PT-F61-25X50 93  
PT-F61-25X60 93  
PT-F80-30X30NS 93  
PT-F80-30X60 93  
PT-F80-30X60NS 93  
PT-F132-34RD 94  
PT-F132-34RDSET 94  
PTX80-30 98  
PTX100-29 104  
PTX100-30 98  
PTX125-29 98  
PTX160-57S 95  
PTX160-77S 95  
PTX-MCZ40L30 101
- ## Q
- QSG1/4-8 319, 323  
QSL-G1/4-8 323  
QST-G1/4-8 323
- ## R
- RD16M12 338  
RD16M1612M12 338  
RD18M1612M12 338  
RP9431SET 339
- ## S
- SET18ZSP40L38-2 156  
SET18ZSP125L85-1 157  
SET18ZSP125L110-2 158  
SFED6W90 196  
SLO 340  
SL1 340  
SL3 340  
SM1135M6X8 322, 338  
SM1135M06X10 338  
SM1135M08X10 338  
SM1135M08X12 338  
SM1135M08X14 338  
SM1135M10X12 338  
SM1135M10X14 338  
SM1135M12X14 338  
SM1135M12X16 338  
SM1135M12X18 338  
SM1135M12X20 338  
SM1135M12X22 338  
SM1135M14X16 338  
SM1135M14X18 338  
SM1135M16X18 338  
SM1135M16X20 338  
SM1135M18X20 338  
SM1135M18X22 338  
SM1135M20X22 338  
SM1135M20X24 338  
SM1135M24X28 338  
SM1136-12 338  
SM1136-14 338  
SM1136-16 338  
SM1136-18 338  
SM1136-20 43, 338  
Smiley 339  
SMK24-24-42OPP200 271  
SMK30-17-42OPP200 271  
SMK301850R50 253  
SMK301855R50 253  
SMK301860R50 253  
SMK301865R50 253  
SMK301870R50 253  
SMK301875R50 253  
SMK351865R50 255  
SMK351870R50 255  
SMK351875R50 255  
SMK351880R50 255  
SMK351885R50 255  
SMK351890R50 255  
SMK351895R50 255  
SMUB2373H220 275

# Index

SMUB3373H220 275

## T

TB150091 146  
TB150092 146  
TB160379 301  
TB170051 142  
TC10 339  
TK150057 174  
TN100668 326, 327  
TN100682 323  
Triag Bit 339  
Triag Bitburr 339  
Triag Ei 340  
Triva Bit 324  
TS150487 323  
TWADAPT10 337  
TWADAPT12 337  
TWADAPT14 337  
TWADAPT16 337  
TWADAPT18 337  
TWADAPT20 337  
TWADAPT22 337  
TWPAS1227 338  
TWPAS1232 195, 338  
TWPAS1240 46, 50, 154, 179, 338  
TWPAS1250 338  
TWPAS16055 338

## U

UA2-260 321, 322  
UA3-360 321, 322  
UA3-560 321, 322  
UA3-660 321, 322  
UA0770 321, 322  
UA182540 318, 321, 322  
UB1-OIL 325  
UB5AXMCZ40-35SET4 118  
UB5AXMCZ40-35SET8 118  
UB5AXMCZ40-45SET8 119  
UB5AXMCZ40-45SET8-ER 119  
UB5AXMCZ4035SET4 118  
UB5AXMCZ4035SET8 118  
UB5AXMCZ4045SET4 119

UB5AXMCZ4045SET4-ER 119

UB5AXMCZ4045SET8-OPBM 286

UB5AXMCZ4045SET8-OPMB 119

UB5AXSET18-3 122  
UBA106110250 321, 325  
UBA106230300 321, 325  
UBA118230600 325  
UBA306400250 325  
UBA318400550 321, 325  
UBS5045 326  
UBT40 325  
UF15030050R50 317, 321  
UF20030050R50 316, 321  
UF30060050R50 315, 321  
UF50050050R50 314, 321  
UP15030040R50G06 317, 320, 321  
UP15030040R50G13 317, 321  
UP20030040R50G06 316, 320, 321  
UP20030040R50G13 316, 321  
UP30060040R50G06 315, 320, 321  
UP30060040R50G13 315, 321  
UP50050040R50G06 314, 320, 321  
UP50050040R50G13 314, 321  
UPB1JN 321, 327  
UPB2JN 321, 327  
US150300 317  
UT1003040 318, 321, 322  
UX1AUT 328  
UZA4012G06 321, 322  
UZA5015G13 321, 322  
UZV16301/4SET 323  
UZV16301/4SET-90° 323  
UZV16301/4SET-T 323

## V

VA168-20PRG 199  
VB1-21-XXXX 206  
VB1-22-XXXX 206  
VB1-23-XXXX 206

VB1-24-XXXX 206  
VB1-41-XXXX 206  
VB1-42-XXXX 206  
VB1-43-XXXX 206  
VB1-44-XXXX 206  
VFP08040L90 (Ø 4 mm) 324  
VFP10065L100 (Ø 6,5 mm) 324  
VS1F19N35-20 186  
VS1F41L30-51 198  
VS1F41N30-60 189  
VS1F48L50-105 200  
VS1F80L30-51 201  
VS1F80N30-36 190  
VS1F80N30-60 191  
VS1F125N49-95 193  
VS1P48L50-105 200  
VS1R19N35-20 186  
VS1R26L35-31 197  
VS1R26N35-26 187  
VS1R38N50-60 188  
VS1R41L30-51 198  
VS1R41N30-60 189  
VS1R80L30-51 201  
VS1R80N30-36 190  
VS1R80N30-60 191  
VS1R80N50-36 190  
VS1R80N50-60 192  
VS1R125N49-95 193  
VS1X59L60H5 203  
VS1X59L60K 202  
VS1X68L20-105 199  
VS2F90N30-60 195  
VS2R80N30-60 194

## W

WU-18 288  
WU-25 288

## Z

ZB150786 141  
ZB150787 141  
ZB150791 150  
ZB150792 150  
ZB170050 142  
ZF211785 286, 287

ZF222333 287  
ZH170537 323  
ZK160798M5 129  
ZSB140L50 150, 151  
ZSB160L50 150, 151  
ZSB180L50 150, 151  
ZSB200L50 150, 151  
ZSM140L50 115, 143, 144  
ZSM160L50 143, 144  
ZSM170L65GH200PCB 145, 146  
ZSM180L50 143, 144  
ZSM200L50 139, 143, 144  
ZSM300L50 144  
ZSMB250L82 147  
ZSMB500L112 147  
ZSP40L38-2 156  
ZSP125L85-1 157, 159  
ZSP150L100 160  
ZSP200L100 160  
ZSP250L100 160  
ZSQ160L50UPRG 148  
ZSQ180L50UPRG 148  
ZSQ200L50UPRG 148  
ZSQP160L50UPRG 148  
ZSQP180L50UPRG 148  
ZSQP200L50UPRG 148  
ZSQP300L50UPRG 148  
ZSX140L50PRG120 142  
ZSX140L50UPRG 141, 283  
ZSX140L50UPRG-OPM 286  
ZSX160L50PRG120 142  
ZSX160L50UPRG 141  
ZSX160L50UPRG-OPM 286  
ZSX180L50PRG120 142  
ZSX180L50UPRG 141  
ZSX180L50UPRG-OPM 286  
ZSX200L50PRG120 142  
ZSX200L50UPRG 141, 154  
ZSX200L50UPRG-OPM 286



**Produktion einer Werkstück Familie**  
*Producing a complete workpiece family*

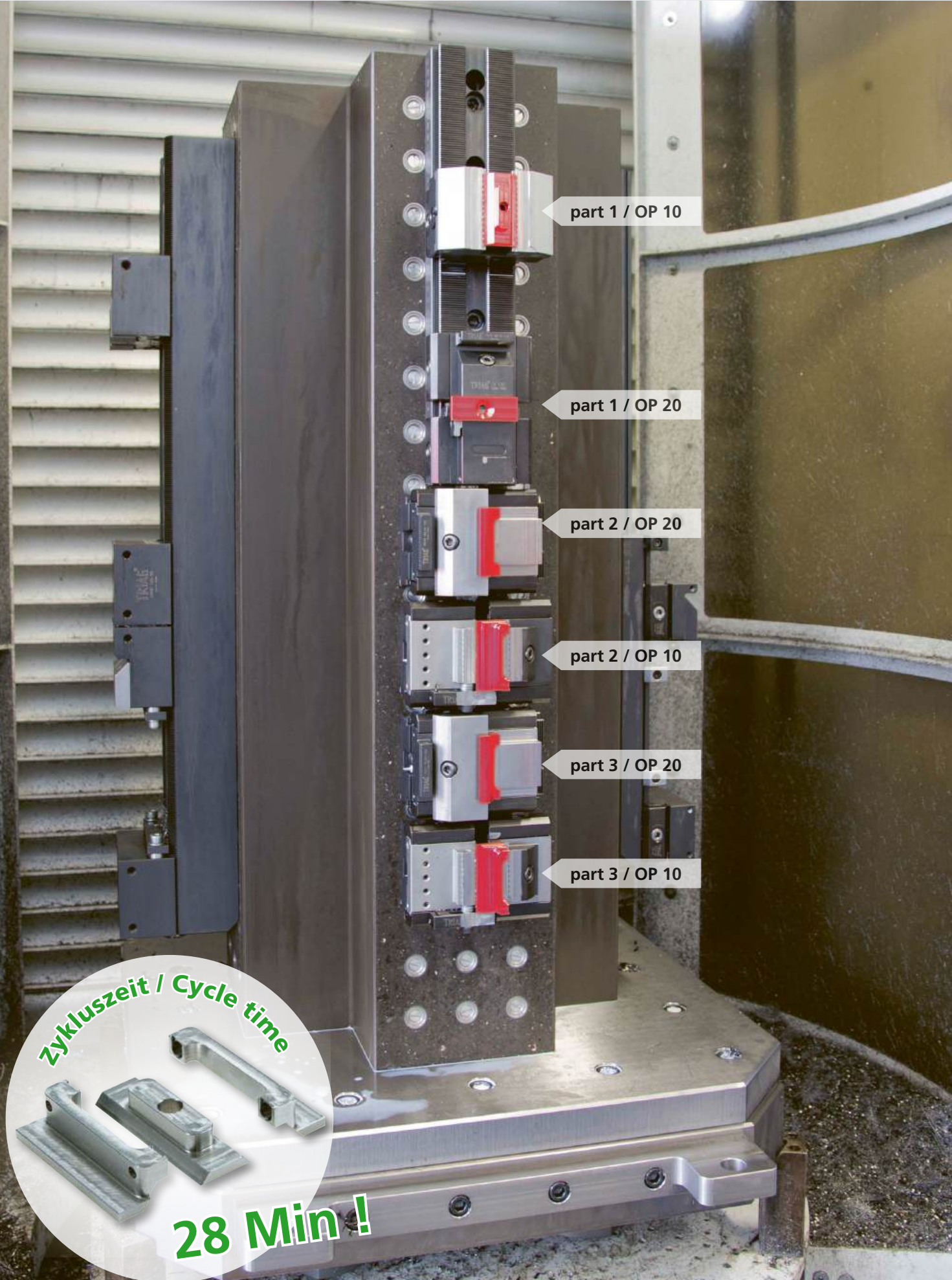

part 1 / OP 10

part 1 / OP 20

part 2 / OP 20

part 2 / OP 10

part 3 / OP 20

part 3 / OP 10

Zykluszeit / Cycle time

28 Min!



### **powerCLAMP & 5axes**

Das schnellstverstellbare Mehrfachspannsystem! Die Positionierung der Spannmodule erfolgt mittels einer Verzahnung auf der Schiene. Befestigung mit nur einer Schraube!

### **powerCLAMP & 5axes**

*The quickest multiple workholding system for easy set up! Positioning of the clamping modules by teeths on the base rail. Repositioning by opening only one single screw!*



### **triCENTRO**

Kleine bis grosse, sowie modulare Zentrischspanner in verschiedenen Ausführungen.

### **triCENTRO**

*Small to big modular self centering vises in different variations.*



### **microCLAMP**

Kleinste Module für den Vorrichtungsbau. Sie haben eine grosse Spannkraft (bis 28'000N), der benötigte Abstand zwischen den Werkstücken ist im Optimalfall nur 15 mm.

### **microCLAMP**

*Smallest modules for dedicated fixtures. Having a high clamping force (up to 28'000N) the distance between workpieces is only 15 mm in optimum set up.*

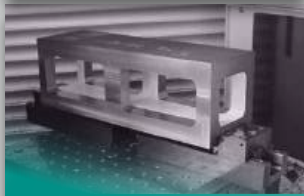

### **aptoCLAMP & 5axes**

Die hohe Spannkraft dieses Systems ermöglicht den Einsatz für schwere Zerspanung.

### **aptoCLAMP & 5axes**

*The high clamping force of the aptoCLAMP enables heavy cuts.*



### **tripoxyMINERAL**

Spanntürme aus Mineralguss. Die Vibrationsdämpfung ist zehnmal besser als bei Grauguss. Das spezifische Gewicht ist hingegen kleiner als bei Aluminium. Erhältlich in vielen verschiedenen Formen.

### **tripoxyMINERAL**

*Tombstones made of composite concrete. Vibration damping effect is ten times better than with cast iron. Specific weight on the other hand is less than aluminium. Available in many different shapes.*



### **oppSystem & 5axes**

Unser Nullpunkt-Palettiersystem ermöglicht ein genaues Positionieren von Mehrfachspannsystemen, Schraubstöcken und Vorrichtungen auf Maschinentischen oder Spanntürmen.

### **oppSystem & 5axes**

*Our zero-point palleting system allows exact positioning of multiple workholding systems, vices and dedicated fixtures on machining tables or tombstones.*



### **trivaCLAMP**

Vakuumspannsystem: Bestens geeignet für plattenförmige Werkstücke (auch nicht magnetische). Es können sowohl Druckstellen als auch Deformationen an labilen Teilen vermieden werden.

### **trivaCLAMP**

*Workholding by vacuum: Suited for plateshaped workpieces (also for non magnetical). Pressure marks as well as deformations on soft parts can be avoided.*



### **triGEL**

Unser Gefrierspannsystem. Sehr gut geeignet für unförmige Teile. Es erlaubt mehrseitiges Bearbeiten ohne Neuspannen. Das Haftvermögen ist sehr gross, wobei die Gefrier- und Auftauzeiten sehr gering sind.

### **triGEL**

*Workholding by freezing: Well suited for strangely shaped parts. It allows processing from more than one side without unclamping. Holding effects are very strong whereas freezing and defrosting times are very short.*

# **swiss** **MODULAR**<sup>®</sup>

**Triag International AG**

Bösch 84 CH-6331 Hünenberg

☎ +41 41 727 27 77

✉ [spannen@triag-int.ch](mailto:spannen@triag-int.ch)

✉ [clamping@triag-int.ch](mailto:clamping@triag-int.ch)

**swissmodular.com**

Official Website

